

Safety Instructions & Operator's Manual for

# SNAPPER®

## LT12D411TV & LT12D411B SERIES LAWN TRACTORS

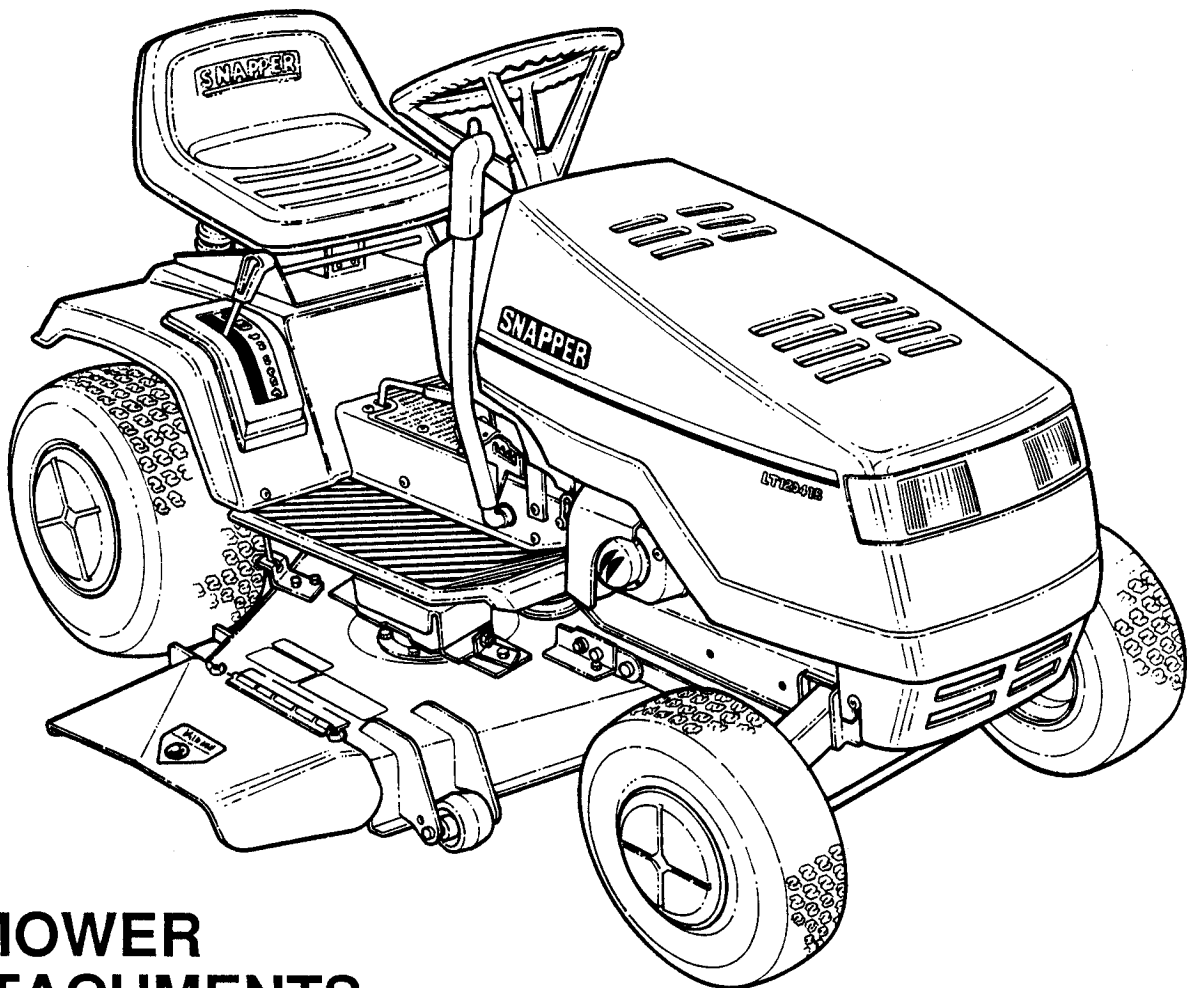

### & MOWER ATTACHMENTS

Thank you for buying a **SNAPPER** product! Before operating your mower, read and follow the Important Safety Instructions (on page 2), the other instructions contained in this manual and the accompanying booklet, "About Power Mower Safety". Lawnmowers, and all power equipment, can be potentially dangerous if used improperly. **REMEMBER: SAFETY REQUIRES CAREFUL USE IN ACCORDANCE WITH INSTRUCTIONS AND COMMON SENSE.**

**SNAPPER POWER EQUIPMENT**  
McDonough, GA., 30253 U.S.A.



MANUAL #1-7107 (11/90)

# IMPORTANT SAFETY INSTRUCTIONS

**WARNING: This powerful cutting machine is capable of amputating hands and feet and can throw objects that can cause injury and damage! Failure to observe the following safety instructions could result in serious injury. Carefully read this manual and question your dealer if something is not clear. Should the dealer be unable to answer to your satisfaction, write or call the Customer Service Department at SNAPPER Power Equipment, McDonough, Georgia 30253 (phone 404-957-9141).**

## PROTECTION FOR CHILDREN

1. DO NOT allow children in yard when machine is operated.
2. DO NOT allow children to ride on machine or on attachments.
3. DO NOT allow pre-teenage children to operate machine.
4. Only responsible teenagers with mature judgement shall be allowed to operate machine and only under close supervision.

## PROTECTION AGAINST TIPOVERS

1. DO NOT operate machine on slopes exceeding 15° (27% grade).
2. On slopes above 10° (18% grade); exercise extreme caution; turn blade OFF when traveling uphill; reduce speed, avoid sharp turns.
3. Avoid uphill starts. If machine is stopped going uphill, turn blade off and back slowly down the slope.
4. DO NOT mow under any condition where traction or stability is doubtful without first test driving over the terrain with blade OFF.
5. Stay alert for holes and other hidden hazards and keep away from ditches, washouts, culverts, fences and protruding objects.
6. DO NOT mow back and forth across face of slopes.
7. KEEP A SAFE DISTANCE (at least three feet) away from edge of ditches and other drop offs.

## OTHER IMPORTANT PRECAUTIONS

1. Read and follow operator's manuals and instructions furnished with attachments.
2. Only mature, responsible persons shall operate the machine.
3. Mount and dismount machine from left side.
4. Wear appropriate protective clothing when mowing such as long pants and substantial footwear, not barefoot or with open sandals.
5. Practice operation of machine with blade OFF to learn controls and develop skill.
6. Persons under the influence of alcohol or drugs must not operate machine.
7. Know how to stop blade and engine quickly in preparation for emergencies.

8. Keep people and pets a safe distance from machine.
9. Shields, deflectors, switches, blade controls and other safety devices must be in proper position and functional.
10. Clear area to be worked of wire, rocks and other objects that could cause injury if thrown by blade.
11. STOP blade, stop engine and remove key when leaving machine.
12. DO NOT operate machine unless properly seated with feet on foot rests or pedal.
13. Keep hands and feet away from rotating blade underneath deck. Never place foot on ground while blade is ON or when machine is in motion!
14. Turn blade OFF, stop engine and wait for blade to stop before attempting to unclog grass or leaves to prevent loss of fingers or hand.
15. Blade must be OFF except when cutting grass. Set cutter in highest position when mowing over rough ground.
16. Deflector or grass catcher must be in position. Never point discharge at people, passing cars, windows or doors. Watch out for traffic when crossing or near roadways.
17. Operate in reverse only after careful observation of entire area behind the machine. DO NOT mow reverse unless absolutely necessary.
18. Service machine and make adjustments only when engine is stopped.
19. Have machine serviced by an authorized Snapper dealer at least once a year and have the dealer install any new safety devices.
20. Use only genuine Snapper replacement parts to assure that original standards are maintained.
21. Tighten all nuts, bolts, screws, frequently and check, adjust, repair or replace brakes as needed.
22. Lubricate machine at intervals specified in manual to prevent controls from binding.
23. Mow only in daylight or with good artificial light.
24. Handle gasoline with care! Never remove cap while engine is running. Fill tank outdoors only with engine stopped and cool. Clean spilled gasoline from machine. Store gasoline in approved container, out of the reach of children, in well ventilated, unoccupied building.
25. DO NOT change engine governor speed settings or overspeed engine.
26. Check grass catcher components frequently for signs of wear or deterioration and replace as needed to prevent injury from items going through weak or worn spots.
27. Exercise caution when pulling loads. Limit loads to those you can safely control and attach loads to hitch plate as specified with Snapper attachment instructions.

# FAMILIARIZATION

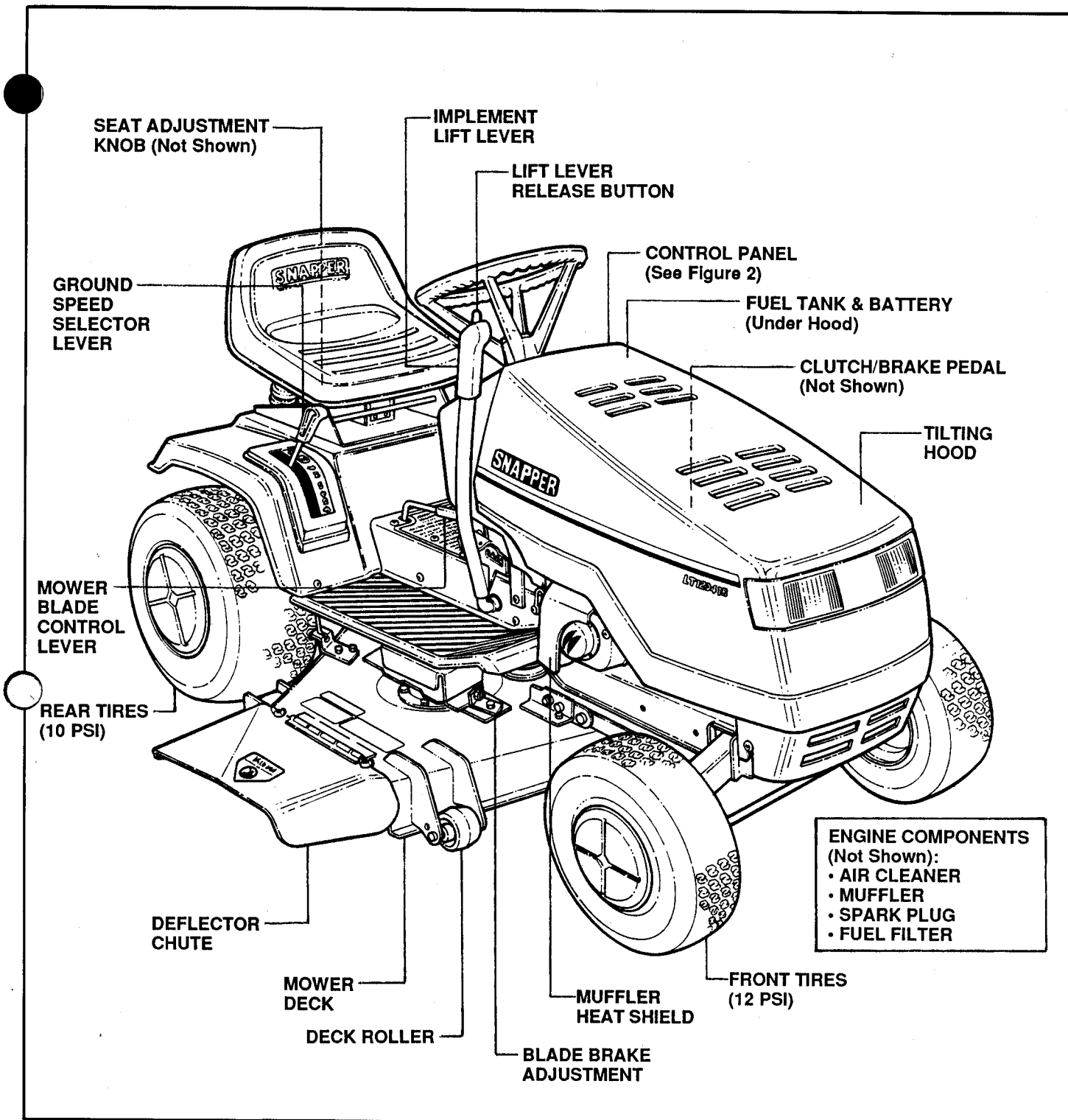

FIGURE 1

## INTRODUCTION

This manual has been prepared for the operators of the **SNAPPER LTD Series LAWN TRACTOR**.

Its purpose, aside from recommending operating and routine service requirements, is to promote safety through the use of accepted operating practices. **READ, UNDERSTAND AND FOLLOW** the SAFETY PRECAUTIONS on page 2 of this manual and all safety messages on the tractor and attachments before operating the machine.

## NOMENCLATURE

The nomenclature drawing above (Figure 1) shows the essential parts of the **SNAPPER LTD Series LAWN TRACTOR**. It is recommended that all operators of this equipment become thoroughly familiar with the controls, parts and operation of this machine before operating. Specific details involving the engine are found in the separate engine owner's manual. Study these manuals before operating and keep both handy for future reference.

# OPERATING INSTRUCTIONS

## BEFORE OPERATING:

Be thoroughly familiar with all controls and how to use them before operating your mower. Know beforehand how to stop the engine, wheel drive and mower blade in preparation for possible emergencies.

## STOPPING

**ENGINE:** *STOP ENGINE* by turning the KEYSWITCH to "OFF". See Figure 2.

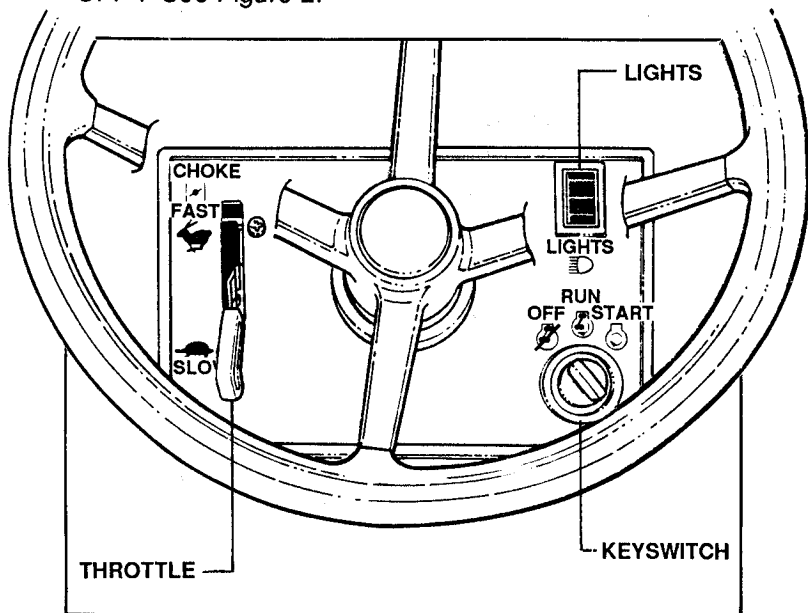

FIGURE 2

**WHEEL DRIVE:** *STOP FORWARD MOTION* of mower by pushing Clutch/Brake pedal all the way down. See Figure 3.

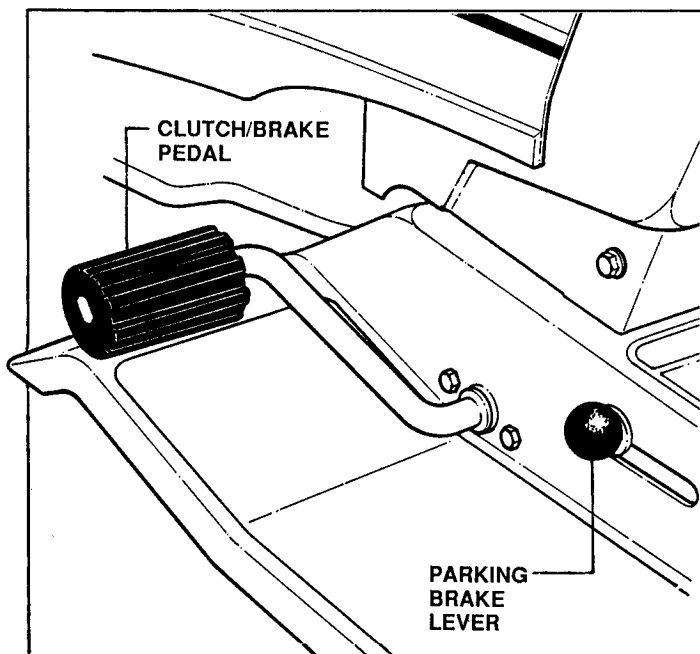

FIGURE 3

**MOWER BLADE:** *STOP MOWER BLADE* by pushing BLADE CONTROL lever downward to "OFF". See Figure 4.

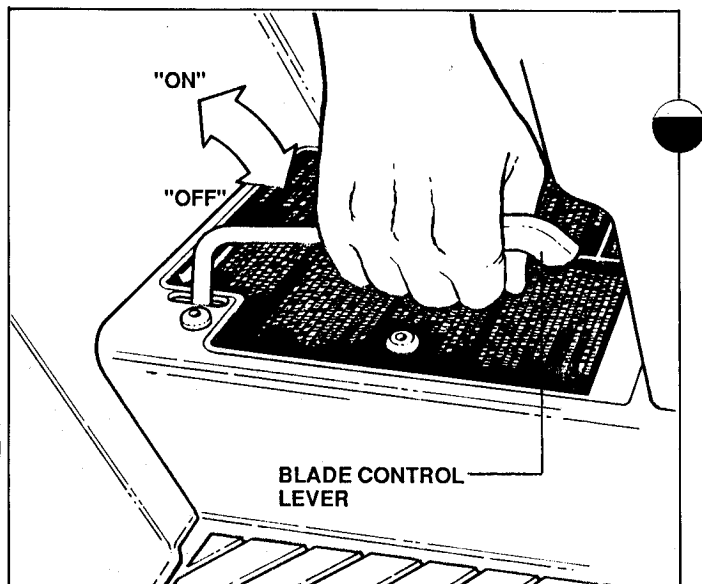

FIGURE 4

## PRE-START CHECK LIST

Make the following checks and perform the service as required before each start up.

- CHECK TIRES and add air as needed to bring pressure to 12 psi in front and 10 psi in rear tires.
- CHECK GUARDS, DEFLECTORS & COVERS to make sure all are in place and securely tightened.
- CHECK BLADE CONTROL to insure it works freely. Blade lever must be moved manually from ON to OFF to stop blade.
- CLEAN EXTERIOR SURFACES of cutting deck and engine of any accumulation of dirt, grass, oil, etc. Keep engine air intake screens and cooling fins clear at all times.
- RE-ADJUST SEAT as needed to most comfortable position. (Refer to Pages 5 & 6, Figure 8)
- CHECK ENGINE OIL and add oil as needed to bring level up to (but not over) the full mark. (Refer to engine manual for oil specifications).
- ADD FUEL to tank after pushing the mower outside where fumes can be dissipated. Make sure cap is tightened after refueling. (Refer to engine manual for fuel specifications). See Figure 5.

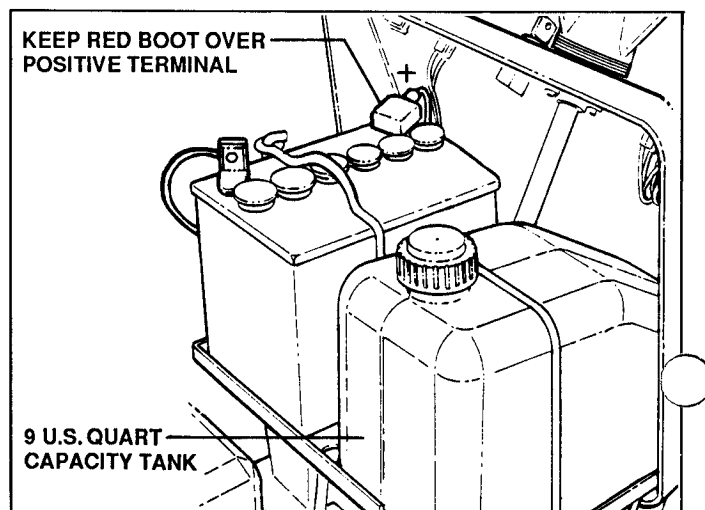

FIGURE 5

# OPERATING INSTRUCTIONS

## STARTING & OPERATING

**ENGINE: START ENGINE** as follows:

1. PUSH BLADE CONTROL LEVER downward to "OFF" position (Fig. 4) and fully depress the CLUTCH/BRAKE pedal (Fig. 7), so that Safety Interlock System will allow engine to start.
2. CHOKE ENGINE for cold starting by moving THROTTLE CONTROL to "CHOKE" position. (Little or no choking will be needed when restarting a warm engine). Refer to Figure 2.

### NOTE

THE SEAT INTERLOCK FUNCTIONS TO SHUT OFF THE ENGINE IN THE EVENT THE OPERATOR VACATES THE SEAT WITH THE TRACTION DRIVE ENGAGED AND/OR THE MOWER BLADE ENGAGED. IN THE EVENT OF AN INTERLOCK MALFUNCTION, DO NOT OPERATE THE TRACTOR UNTIL THE CONDITION IS CORRECTED.

3. Insert key in ENGINE IGNITION switch, turn key to "START" position to crank engine and hold until engine starts then release.

### NOTE

LIMIT CRANKING INTERVALS TO FIVE SECONDS DURATION TO PREVENT OVERHEATING OF STARTING MOTOR AND/OR DEPLETION OF BATTERY ENERGY. NORMALLY, FIVE SECONDS IS SUFFICIENT CRANKING TIME FOR STARTING. IF THIS TIME IS EXCEEDED, LOCATE AND CORRECT CAUSE OF STARTING PROBLEM.

4. WARM-UP ENGINE momentarily, then move the THROTTLE CONTROL downward out of CHOKE position until engine runs smoothly. Set desired speed. Best cutting and bagging performance is obtained with engine at or near top speed.

## TO START MOTION

After the engine has been started and is running smoothly, proceed as follows to start forward or rearward motion.

1. With CLUTCH/BRAKE pedal depressed, shift SPEED SELECTOR to **1** for forward or **R** for reverse and release pedal. (For comfort and safety, always shift back to **1** before starting forward). See Figure 6.

### CAUTION

AVOID UPHILL STARTS. IF MACHINE IS STOPPED GOING UP SLOPE, PUSH **BLADE CONTROL LEVER** DOWNWARD TO "OFF" POSITION AND BACK SLOWLY DOWN SLOPE. IF UPHILL START MUST BE MADE, PUSH **BLADE CONTROL LEVER** DOWNWARD TO "OFF" AND SET THROTTLE AT HALF SPEED.

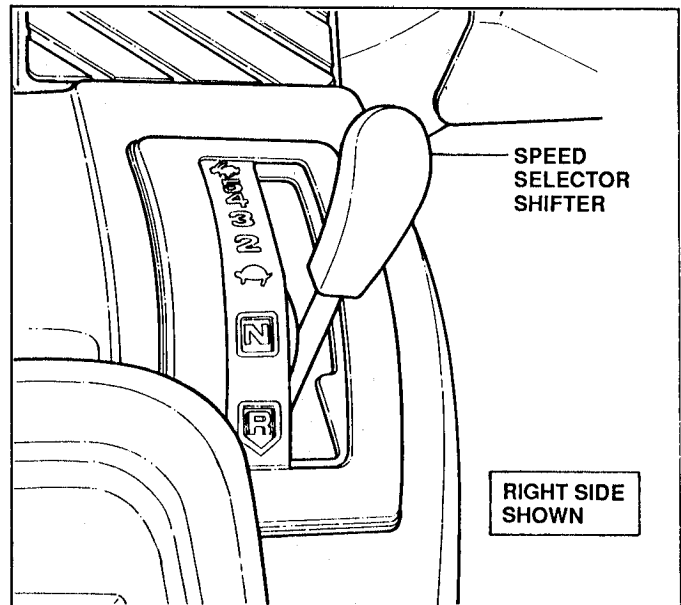

FIGURE 6

## TO STOP MOTION

Push CLUTCH/BRAKE PEDAL all the way down to stop forward or rearward motion.

## TO SET PARKING BRAKE

Depress CLUTCH/BRAKE PEDAL. Pull PARKING BRAKE LEVER "UP" while releasing pedal. See Figure 7.

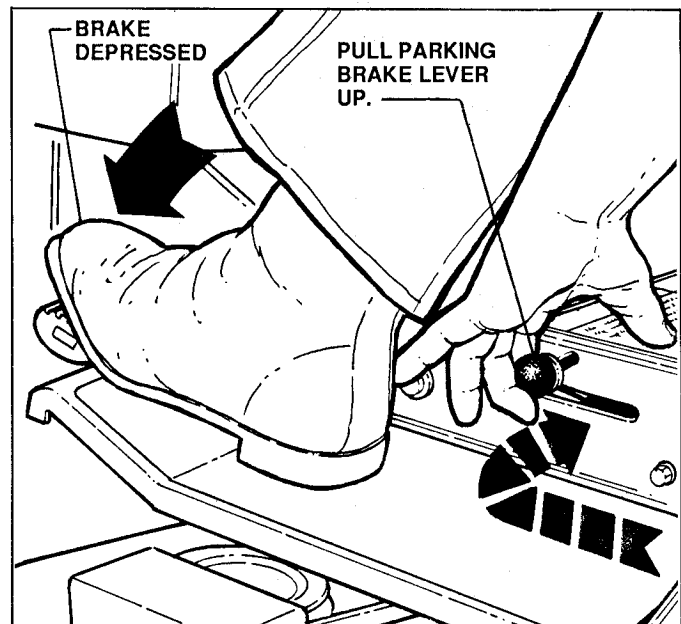

FIGURE 7

Push CLUTCH/BRAKE PEDAL down to release PARKING BRAKE.

## TO ROLL MACHINE

Shift SPEED SELECTOR to "N" position or hold CLUTCH/BRAKE PEDAL half down.

# OPERATING INSTRUCTIONS

## TO ADJUST OPERATOR'S SEAT

**FORE & AFT ADJUSTMENT:** With machine stopped, loosen the ADJUSTING KNOB on seat support. Sit in operators seat and, while depressing the CLUTCH/BRAKE PEDAL, slide the seat forward or rearward to the most comfortable position, then lock in position by tightening ADJUSTING KNOB. See Figure 8.

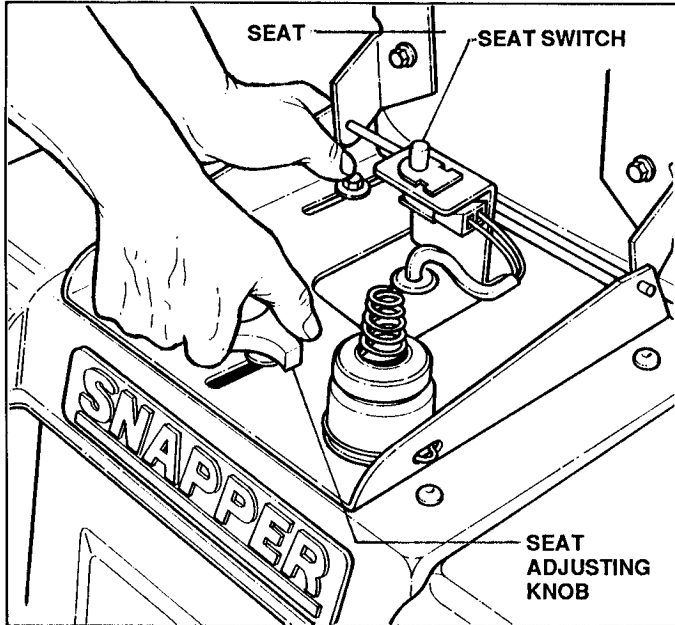

FIGURE 8

## TO OPERATE MOWER

During transport or for clearance through gates it may become necessary to raise the DISCHARGE DEFLECTOR. Reinstall the wing nut on the studs when the DEFLECTOR is raised so they will not be lost. Be sure to lower the DEFLECTOR and clamp it securely down with the wing nuts before mowing. See Figure 9.

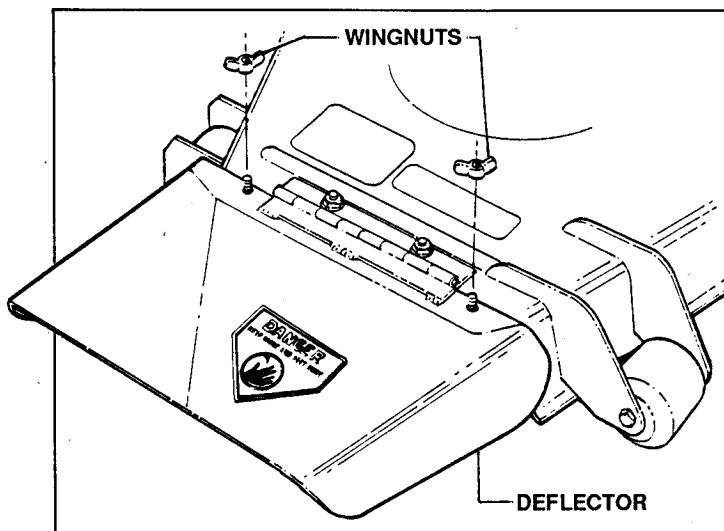

FIGURE 9

## TO ADJUST CUTTING HEIGHT

The cutting height can be changed to any one of nine positions by raising or lowering the cutting deck attachment with the IMPLEMENT LIFT LEVER as shown in Figure 10.

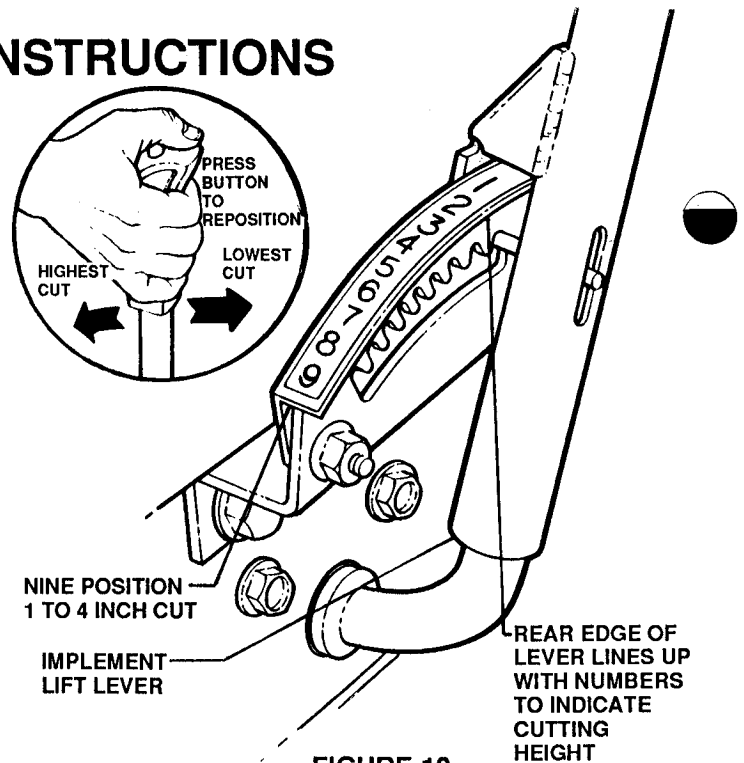

FIGURE 10

To suit mowing conditions, experiment by increasing engine speed and/or decreasing driving speed until smoothest cut is obtained without placing engine under a heavy strain.

## TO START MOWER BLADE

**START MOWER BLADE** by pulling BLADE CONTROL LEVER "UP" to "ON". See Figure 10A.

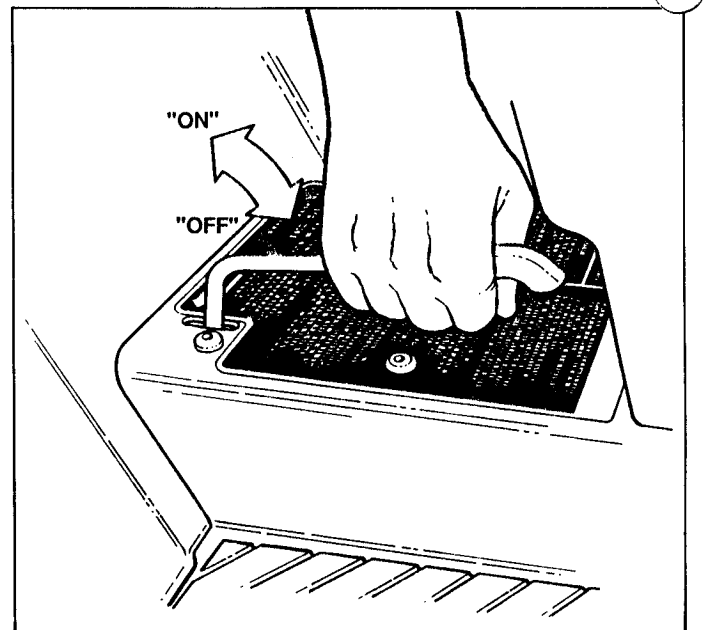

FIGURE 10A

## TO BE ABLE TO GET OFF MOWER AND LEAVE ENGINE RUNNING:

1. Push BRAKE all way down.
2. Set PARKING BRAKE.
3. Push BLADE CONTROL LEVER downward to "OFF" position. Refer to Figure 10A.

# SERVICE

To retain the quality of your tractor, use Genuine **SNAPPER** Replacement Parts only. Contact your local **SNAPPER** Dealer for parts and service assistance. For the correct part or information for your particular mower, always mention model and serial number. We recommend returning the tractor to an authorized **SNAPPER** Dealer on a yearly basis for inspection and addition of any new devices which might upgrade the safety of your mower. For the nearest **SNAPPER** Dealer, check the yellow pages under the heading **LAWN MOWERS**. For engine parts and service, look for the engine manufacturer's dealers under the heading **ENGINES-gasoline**.

## DRAINING ENGINE OIL

### NOTE

RAISE HOOD. (IT MAY BE MORE CONVENIENT TO REMOVE HOOD FOR EASIER ACCESS WHEN FILLING WITH OIL. SEE "HOOD REMOVAL", PAGE 12.)

1. Disconnect spark plug wire.
2. Fashion an oil drain trough from metal or cardboard as shown in Figure 11.

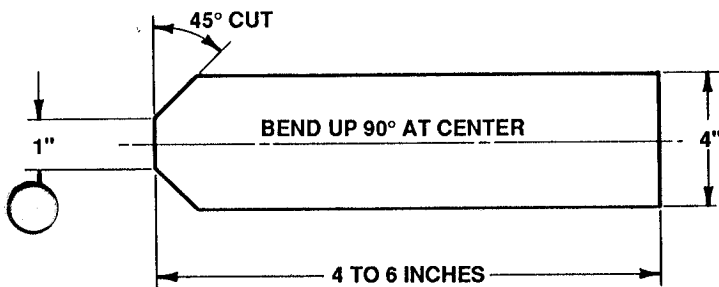

FIGURE 11

3. Loosen oil drain plug. Place trough under plug. Place a flat container (2 qt. Min. Capacity) beneath end of oil drain trough.

### NOTE

TO ACHIEVE PROPER OIL DRAINAGE, IT MAY BE NECESSARY TO PLACE BLOCKS UNDER LEFT WHEELS OF TRACTOR.

4. Loosen oil fill cap and remove oil drain plug. Allow engine oil to drain completely. See Figure 12.

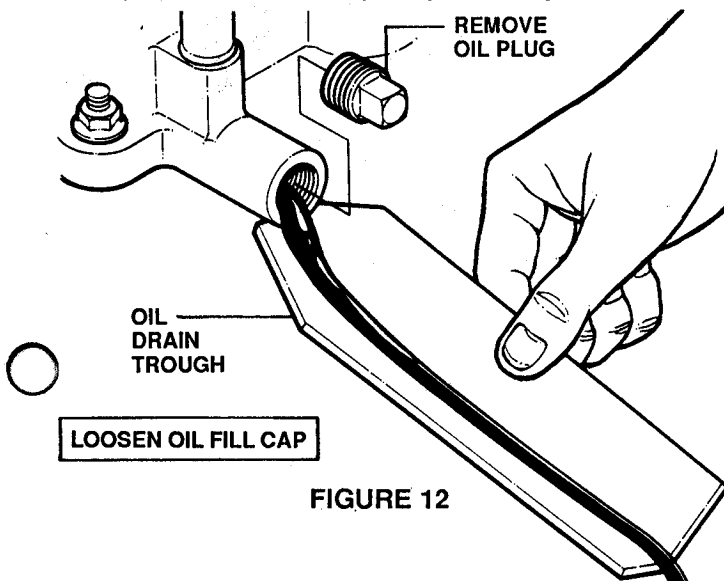

FIGURE 12

5. Reinstall oil plug, remove fill cap and refill crankcase with oil. Refer to the Engine Owner's Manual for engine oil specifications.

## MAINTENANCE & LUBRICATION SCHEDULE

Refer to the Engine Owner's Manual for service specifications on the engine itself. The following applies primarily to the tractor and optional mower attachments. Clean fittings before greasing.

### FIRST 5 HOURS (NEW UNIT)

- ENGINE: Change oil in crankcase. Refer to Engine Owner's Manual, and Draining Engine Oil instructions on this page.
- TRACTOR: Check all fasteners and retighten as needed.

### EVERY 25 OPERATING HOURS

- FRONT WHEEL BEARINGS: Lubricate bearings through the fitting on hub of each front wheel. See Figure 13.

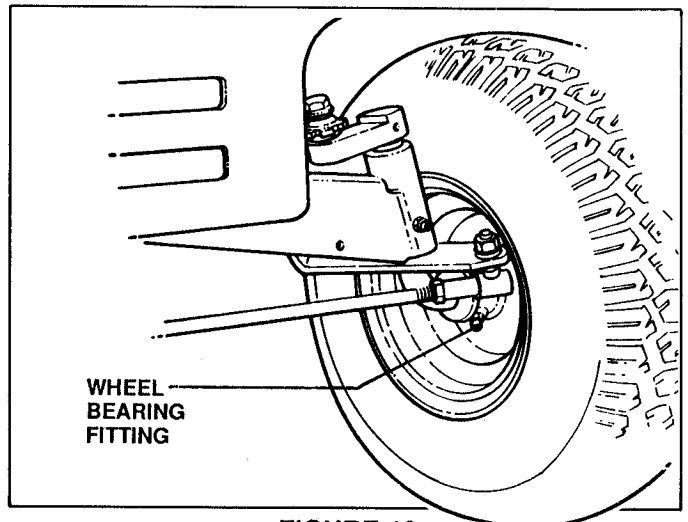

FIGURE 13

- REAR LEFT AXLE BEARING: Lubricate through fitting with 2 shots of bearing grease. Right hand bearing is lubricated by transmission.
- FRONT AXLE PIVOT & SPINDLE BUSHINGS: Lubricate the center pivot fitting on underside of the front axle and each spindle fitting located on rear of front axle (toward operator). See Figure 14. (Continued on next page)

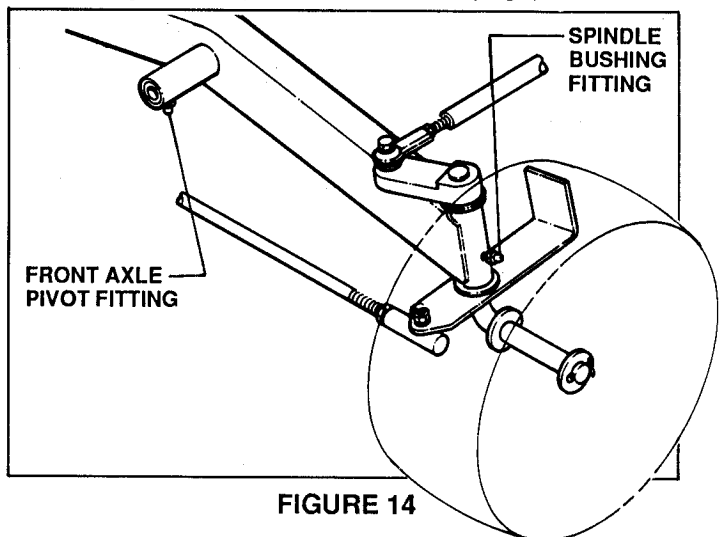

FIGURE 14

## SERVICE (Continued)

- CHANGE OIL IN ENGINE CRANKCASE with oil of weight and grade specified in Engine Owner's Manual.
- ENGINE AIR CLEANER: Refer to Engine Owner's Manual for details.

### END OF EACH SEASON (OR EVERY 100 HOURS)

- TRANSMISSION DIFFERENTIAL: Remove rear panel or fender seat pan to gain access to differential. See Figure 15.
- TO REMOVE REAR PANEL:
  1. Remove six (6) screws.
  2. Remove REAR PANEL.
- TO REMOVE FENDER SEAT PAN:
  1. Remove shift handle knob.
  2. Disconnect wires to seat switch.
  3. Remove four (4) top screws.
  4. Remove two (2) lower fender screws.
  5. Remove FENDER SEAT PAN from tractor.

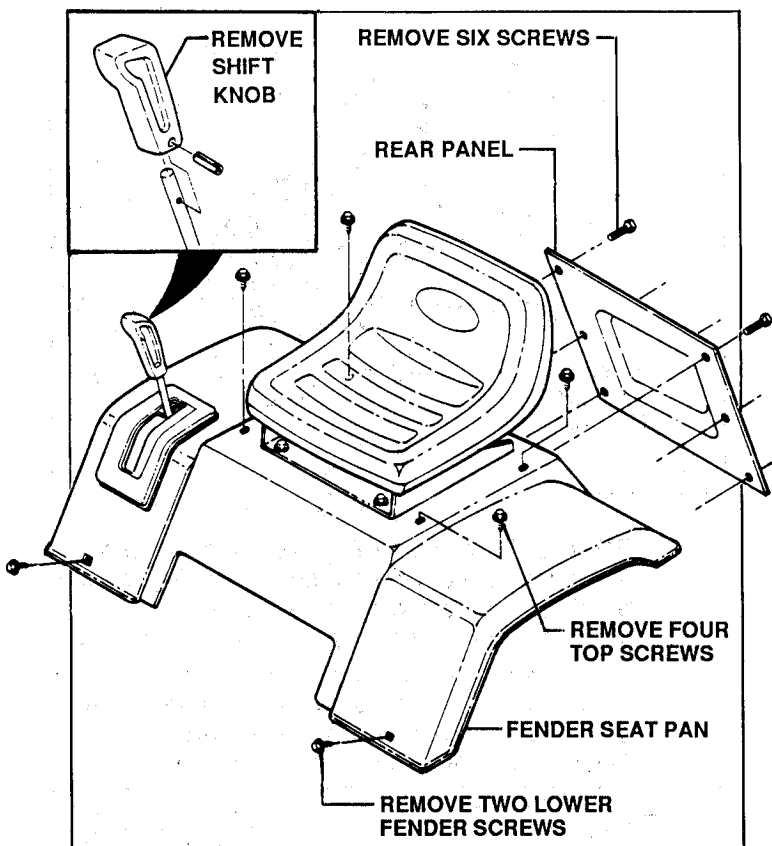

FIGURE 15

- CHECK GREASE LEVEL by removing CHECK PLUG on inside of unit shown in Figure 16 to check level of oil. Add **SNAPPER "0"** grease as needed thru upper fill hole to bring the level up to the lower edge of the CHECK PLUG hole. Reinstall **NEW** plugs after servicing.
- CHAIN CASE: Remove plug and check. If dry, add one ounce of **SNAPPER "0"** grease—do not overfill. Total capacity must not exceed 2 ounces. See Figure 16.

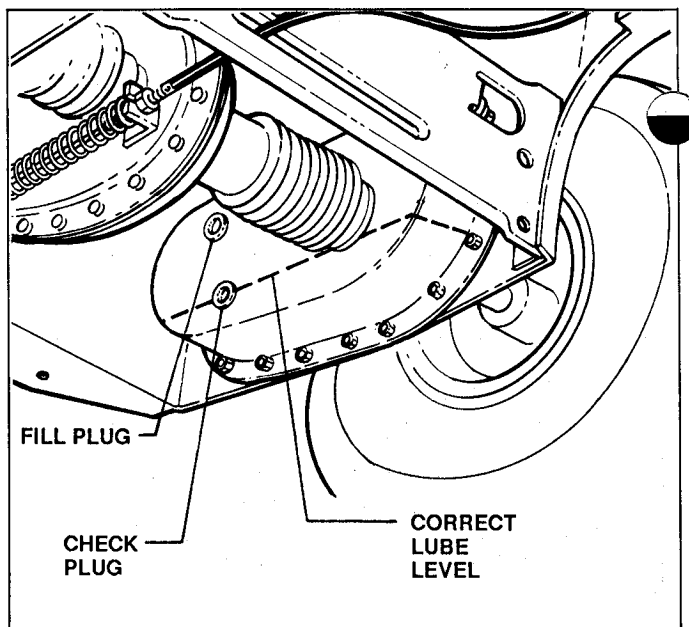

FIGURE 16

- MOWER ATTACHMENT SPINDLE(S): Lubricate fitting for BLADE SPINDLE BEARINGS with two shots only of bearing grease once each year.
- SERVICE Engine air cleaner element and spark plug.
- SERVICE FUEL FILTER as instructed below.

### FUEL SYSTEM SERVICE

Check the in-line fuel filter at frequent intervals and replace before the screen becomes clogged with sediment. Make sure the replacement is correctly installed with **IN** marking toward the tank and **OUT** toward the engine. Check the fuel system components frequently and replace any parts showing worn spots or cracks. See Figure 17.

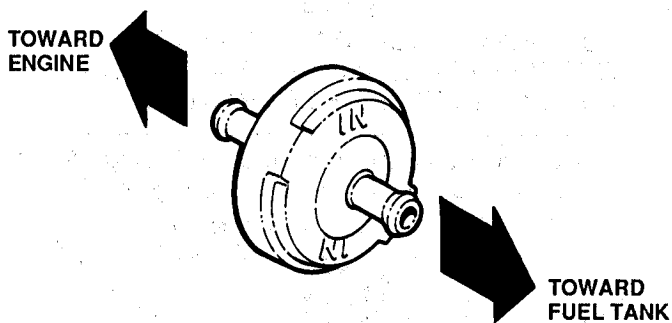

FIGURE 17

### BATTERY SERVICE

Check the battery once each month. Remove the caps and add distilled water as necessary to bring the level of the electrolyte up to about 3/32" over plates in each cell. **DO NOT FILL TO THE RINGS.** Carefully reinstall battery caps. In freezing weather, charge the battery after adding water to thoroughly mix the water in the electrolyte. Keep the terminals and cables clean and tight and make sure the red boot (shown in figure 5) remains in position over the positive terminals. Always disconnect black cable from negative (-) terminal first and reconnect last!



# SERVICE (Continued)

## BATTERY CHARGING

The engine is equipped with a flywheel alternator to charge the battery. If the tractor is not run regularly, connect the battery to a charger monthly to maintain the specific gravity at 1.250 or higher. If this reading falls below 1.175, the battery liquid may freeze when temperatures drop to around zero degrees F.

To charge, connect per instructions furnished with charger. If time allows, slow charge at 1 amp for ten hours or as an alternate, fast charge at 3 amps for four hours. Observe all precautions while charging.

## TO ADJUST TIRE PRESSURE

Check tire pressure at frequent intervals. A low tire on one side causes uneven mowing. Pressure in front tires should be maintained at 12 psi while rear tire pressure should be 10 psi.

## DRIVEN DISC SERVICE

If the drive does not engage after extended use, it may be that the driven disc is excessively worn and is not contacting the drive disc. The driven disc must be replaced if the rubber is worn down to 1/16" above the metal. Replace the rubber driven disc when excessively worn or unevenly worn. To replace, remove the rear cover plate, shift the drive into neutral, remove the four nuts from the hub, remove the old disc and replace it with new disc. See Figure 18. Refer to Page 15 for TRACTION LOSS ADJUSTMENT procedure.

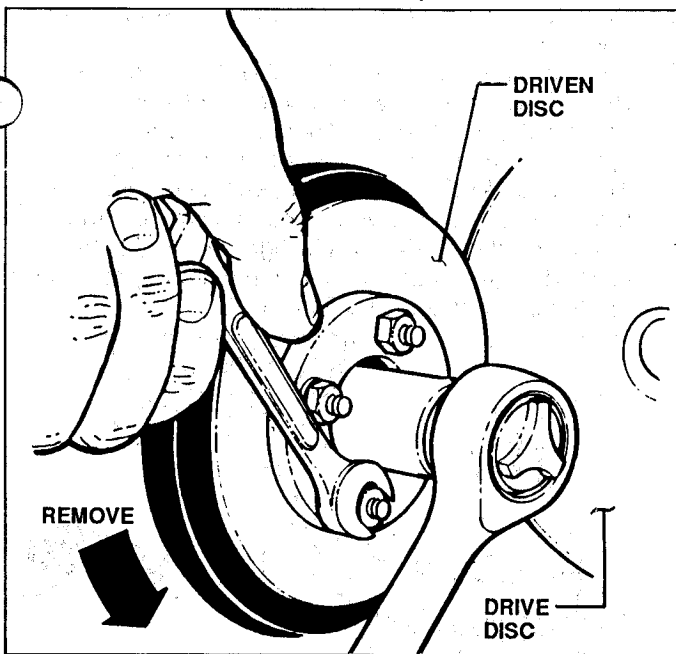

FIGURE 18

## WHEEL BRAKE TEST & READJUSTMENT

1. Test the wheel braking action at frequent intervals to insure to insure proper stopping in the event of possible emergencies. Normally, the mower should stop from top forward speed within approximately three feet after the CLUTCH/BRAKE pedal has been fully depressed.
2. To adjust the braking action:  
Loosen Locknut and adjust the cable housing toward the rear of the mower to increase cable tension. See Figure 19.

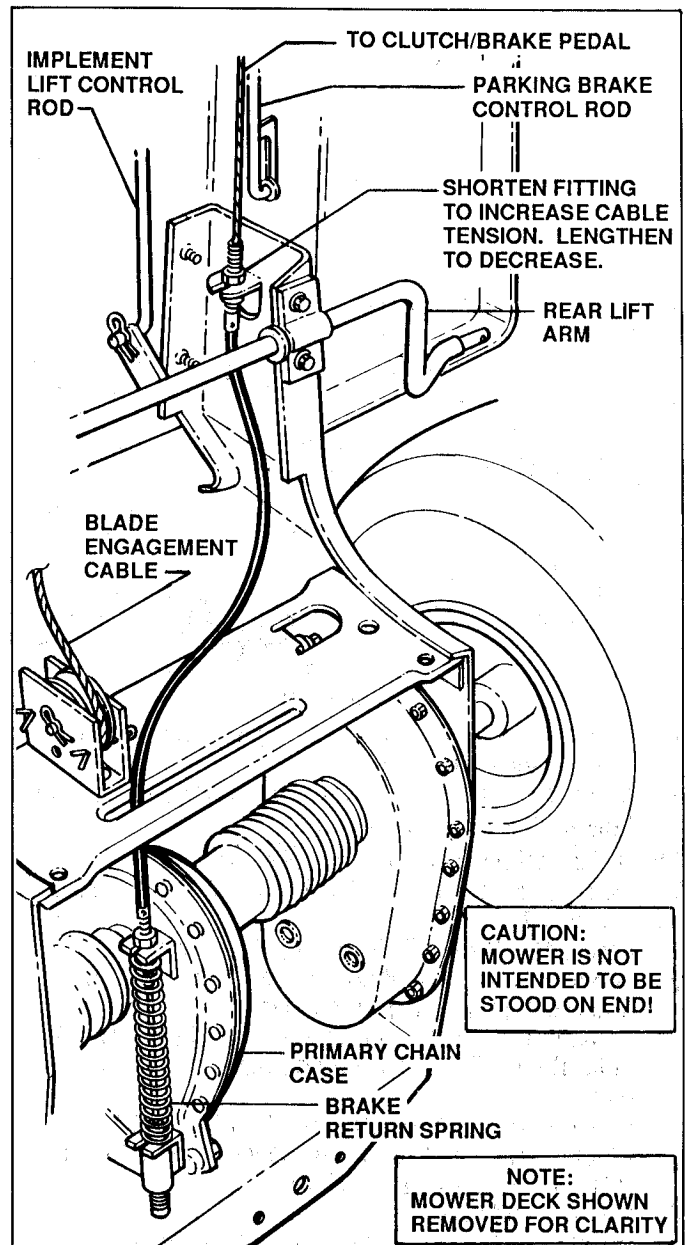

FIGURE 19

3. After adjusting, put the Speed Selecting lever in sixth (6th) position. Depress the CLUTCH/BRAKE pedal slowly as you roll the mower. There should be a place where the CLUTCH is disengaged and the brakes not yet applied, allowing the machine to roll. This should occur in the first half of the pedal travel.
4. Retest braking action as described in Step 1.

## MOWER DRIVE BELT ADJUSTMENT

Normally, within the first few hours of operation, the MOWER DRIVE BELT will seat into the pulleys and become slack. To regain correct belt tension, follow steps 1 thru 5.

1. Lower MOWER DECK to lowest position.
2. Push BLADE CONTROL lever downward to "OFF" position.
3. Remove BLADE CABLE SPRING from hole in BRAKE ARM. Reattach spring in next hole forward. See Figure 20.

(Continued on next page)

## SERVICE (Continued)

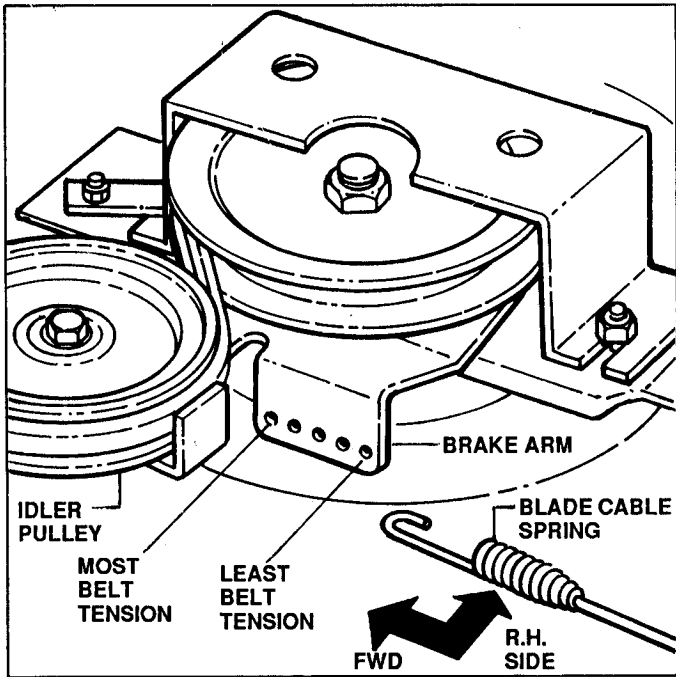

FIGURE 20

4. Pull BLADE CONTROL lever up to "ON" position, then check belt tension.
5. If belt is still too slack, move spring forward another hole until tension is correct.

### MOWER DRIVE BELT SERVICE

To install or replace the MOWER DRIVE BELT, follow steps 1 thru 9.

1. Lower MOWER DECK to lowest position.
2. Loosen screw on slotted side of belt covers and swing covers away from pulleys.
3. Loosen pulley screw on stationary IDLER PULLEY until BELT RETAINER can be moved away from belt.
4. Loosen pulley screw on BRAKE ARM IDLER PULLEY until belt can be removed from between BELT RETAINER and PULLEY.
5. Remove old belt.
6. Route new belt around pulleys as shown in Figure 21.

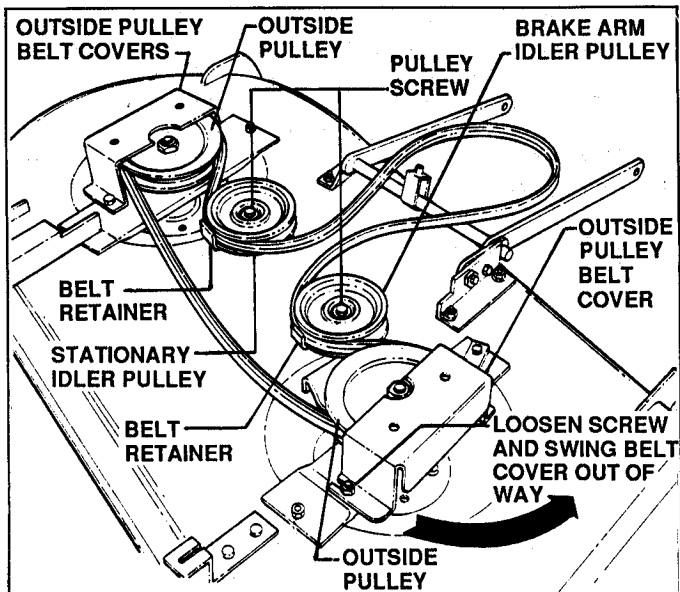

FIGURE 21

7. Retighten BRAKE ARM IDLER PULLEY screw.
8. Readjust BELT RETAINER on stationary IDLER PULLEY, then retighten pulley screw.
9. Reinstall belt covers on outside pulleys. Tighten retaining screws.

### MOWER SERVICE & ADJUSTMENTS

Keep the topside of the mower free of grass cuttings. Buildup of clippings could cause belt problems and also might present potential fire hazard especially when dry. If uneven cutting is noted, check the tire pressure first as this is the most common cause. If tire pressure is correct and uneven cutting persists, move the tractor to a flat level surface, such as a garage floor, and check the deck level. (See "LEVELING MOWER", Page 13).

To prolong the life and efficiency of your mower, keep the underside of deck clean and free of accumulated grass clippings by washing it down with a hose and/or scraping with a wire brush and scraper. Make sure this is done at the end of the cutting season before placing the mower in storage.

### BLADE BRAKE ADJUSTMENT

The BLADE BRAKE assembly is designed to stop blade rotation within 3 seconds after the BLADE CONTROL lever has been pushed downward to "OFF". Should the blades not stop within 3 seconds, the BLADE BRAKE must be adjusted as follows:

1. Lower deck to lowest position.
2. Push BLADE CONTROL lever downward to "OFF" position.
3. Loosen retaining nut on R.H. OUTSIDE PULLEY BELT COVER and swing cover out of way.
4. Inspect BRAKE BAND closely to determine approximate amount of adjustment required.
5. Tighten BRAKE BAND by loosening jam nut and turning T-nut on end of eyebolt, clockwise 1 to 2 turns, or until BRAKE BAND tightens. Make sure flanged lip on T-nut is positioned vertically to fit over top edge of anchor. See Figure 22.

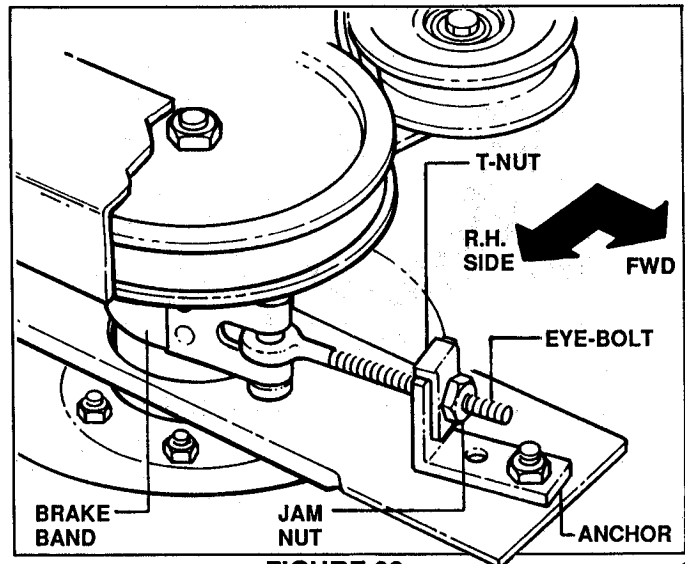

FIGURE 22

#### NOTE

MAKE SURE THAT BRAKE BAND DOES NOT DRAG AFTER ADJUSTMENT.

# SERVICE (Continued)

- After adjusting BLADE BRAKE, start mower, engage blade and then disengage blade to check stopping time. Readjust if necessary.

## CUTTING BLADE SERVICE

Check at frequent intervals to make sure the blade is securely tightened and that it is in good condition.

Replace blade if badly chipped, bent, out of balance, or as soon as notch starts wearing in the tip between the flat surface and upturned lift as depicted in Figure 23. This type wear pattern occurs more rapidly under sandy soil conditions.

### CAUTION

NEVER OPERATE THE MOWER WITH BLADE WORN TO THE EXTENT SHOWN IN VIEW C AS THE TIP COULD FLY OFF CAUSING PERSONAL INJURY OR PROPERTY DAMAGE.

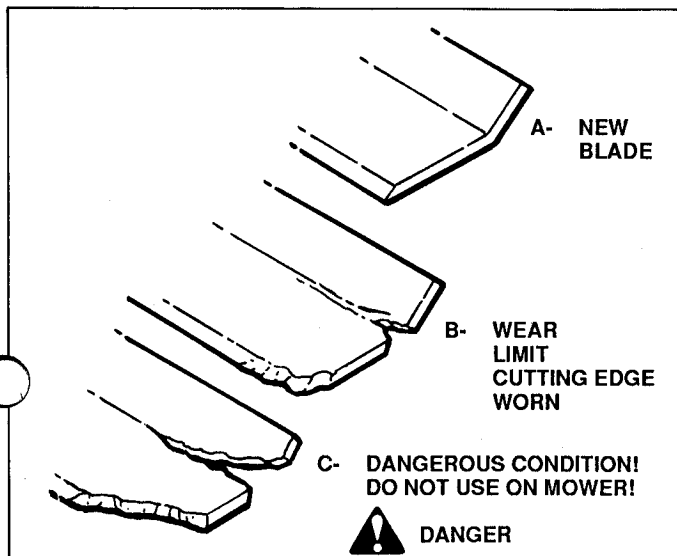

FIGURE 23

Sharpen blade when the cutting edges become dull if the blade is in otherwise good condition. When dull, the cut grass ends will be ragged and usually turn brown soon after mowing. For best results, remove the blade and sharpen it on a grinding wheel at an angle of 22 to 28 degrees. The cutting surface should extend in about 2 1/2" from the tips. Check the blade after sharpening to determine that it is still balanced. It will cause excessive vibration if unbalanced. See Figure 24.

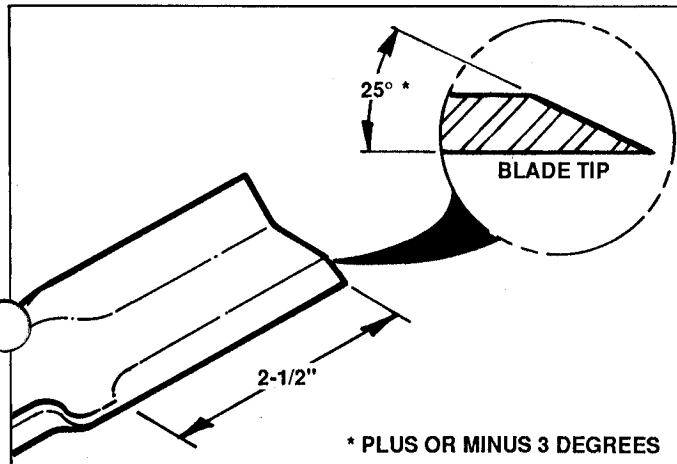

FIGURE 24

**CAUTION**  
**AVOID CUTTING YOURSELF ON CUTTING BLADE! PROTECT YOUR HANDS FROM CUTS WHILE HANDLING BLADE - WEAR GLOVES!**

Install sharpened or replacement blade with components in same sequence as removed. Make sure that the flange on each side of blade fits over the edge of the BLADE BAR when installing. Do not substitute any components here. Tighten the blade retaining capscREW to 20-30 foot pounds torque value. See Figure 25.

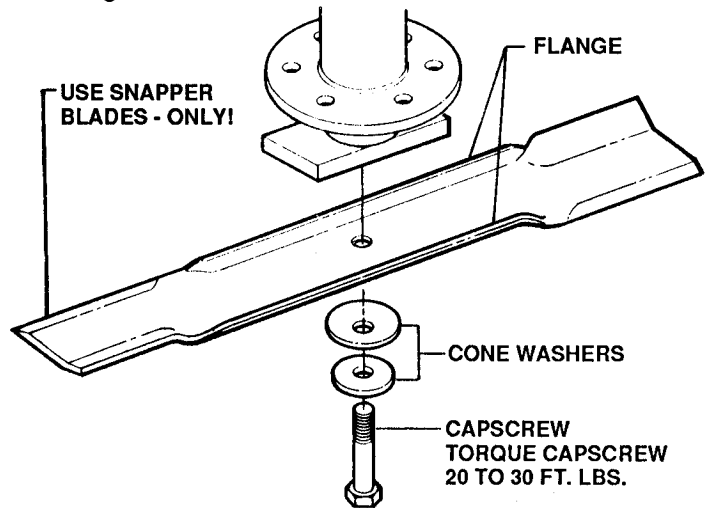

FIGURE 25

## REMOVING & INSTALLING MOWER

The mower is attached to the tractor and leveled at the factory. If the mower is to be removed for cutting blade service, or to install another attachment, be sure that the mower settings remain unchanged.

### TO REMOVE MOWER:

- Lower deck to lowest position.
- Remove hairpin from FRONT LIFT BRACKET CABLE clevis pin. See Figure 26.

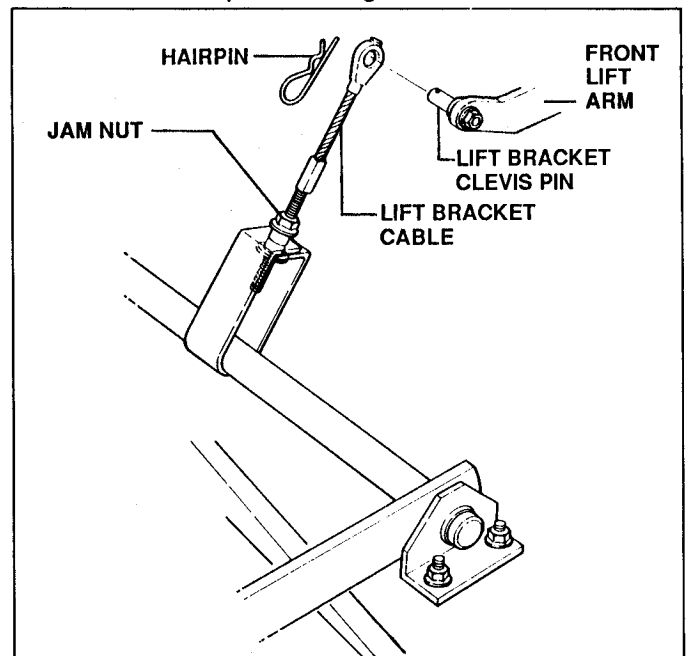

FIGURE 26

# SERVICE (Continued)

3. Remove hairpins and washers from REAR LIFT CABLES. See Figure 27.

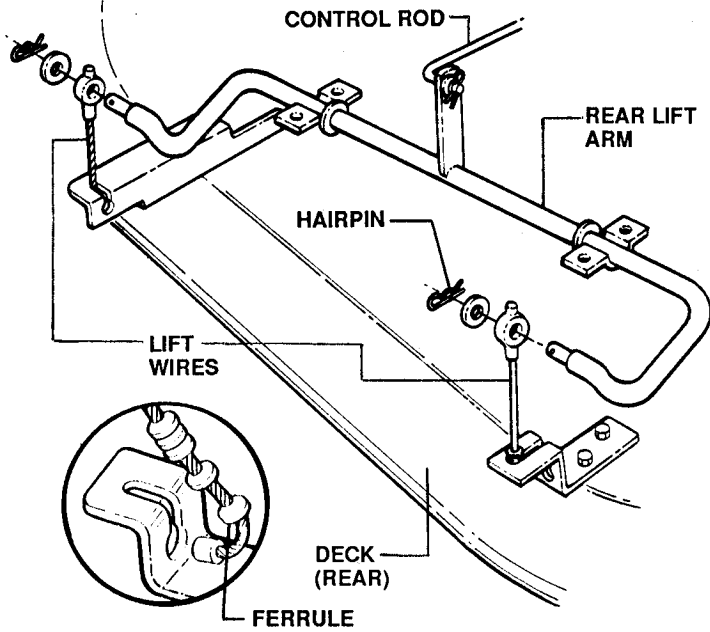

FIGURE 27

4. Remove hairpins and clevis pins from FRONT LIFT ARMS. See Figure 28.

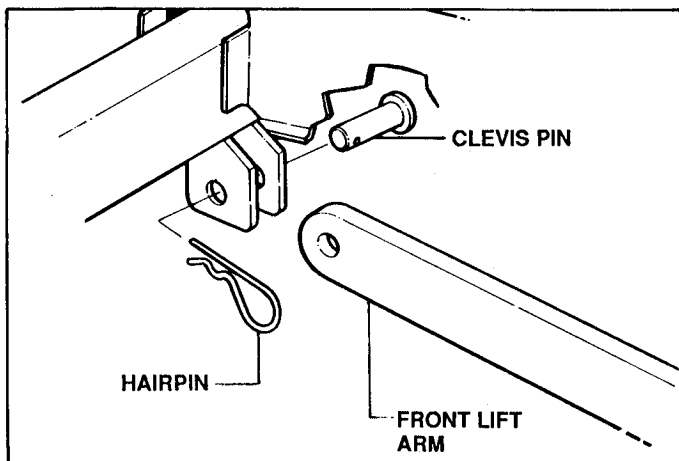

FIGURE 28

5. After deck has been lowered to ground, turn tractor's front wheels to the left and slide the mower out from the right side. Reverse steps 1 thru 5 to reinstall mower.

## HOOD REMOVAL

To service engine (changing oil, spark plug, etc.). It is recommended that the hood be removed. Hood removal is as follows:

1. Disconnect headlight wire at lower left front of hood.
2. Tilt hood one half maximum distance, then lift straight up to remove. There will be some resistance from the retaining pins, requiring a slight "tug". See Figure 29.
3. Remove hood and lay aside until maintenance is completed. Reinstall hood in reverse order, noting that some pressure is required to "snap" hood tabs down into proper position past retaining pins.

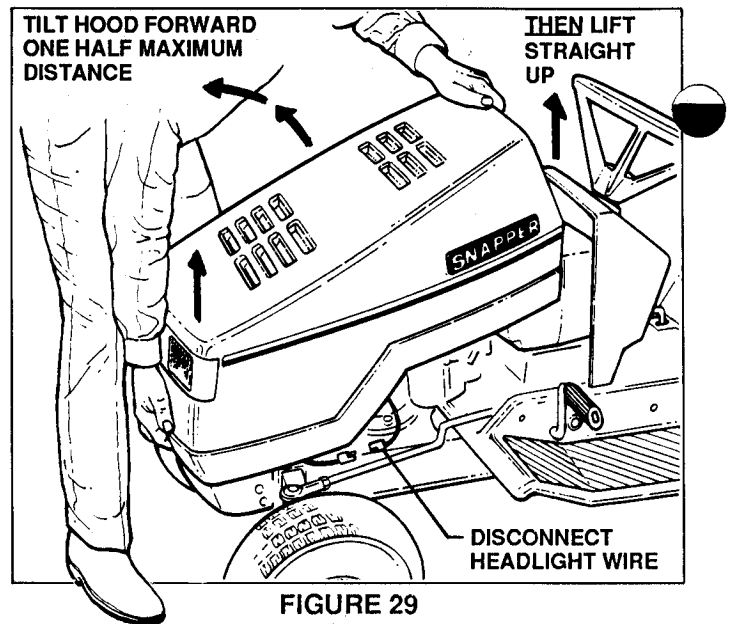

FIGURE 29

## ADJUSTING STEERING

If steering develops excessive free-play, then the eccentric steering bolt must be adjusted. Proceed as follows:

1. Working from the left side of the tractor, use a 7/16" wrench to loosen nut on top of carriage bolt. See Figure 30.
2. Push eccentric clockwise (towards R.H. side of tractor) until free-play in steering wheel is minimized.
3. Retighten nut.

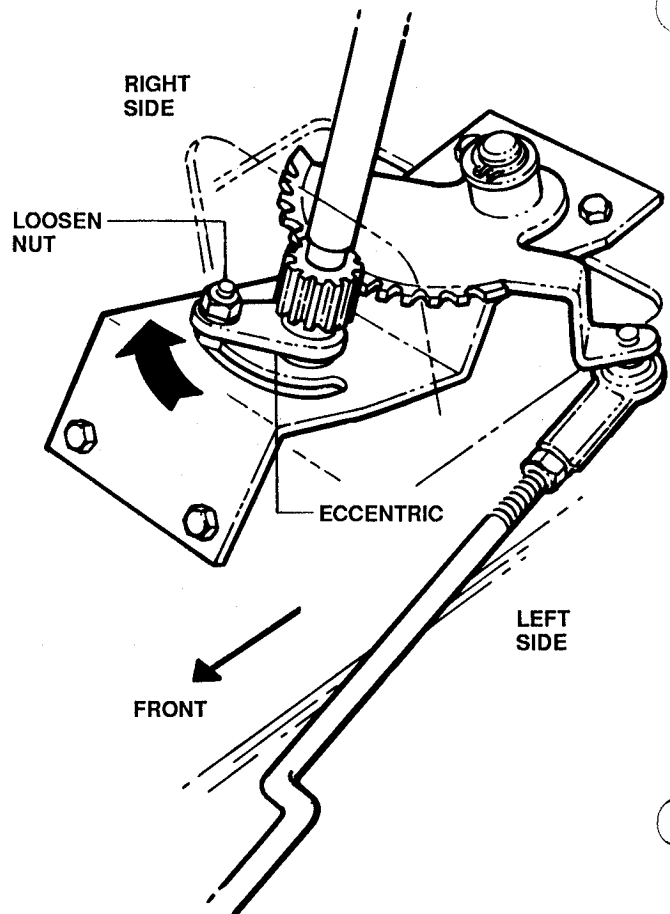

FIGURE 30

# SERVICE (Continued)

## LEVELING MOWER

With the blades sharpened and properly aligned, a level mower deck will insure a clean, even cut. The mower should be checked for levelness as follows:

1. Check the air pressure in the tires and correct pressure as needed (12 psi front and 10 psi rear tires).
2. Move the tractor to a smooth, flat and level area such as garage floor.
3. Move the lift lever to #5 notch.
4. Place a 2 x 4 block on edge under the front lip of the deck in the exact center between the front lift arms.
5. Loosen the jam nut on the front lift cable and adjust until the front lip of the deck rests on the 2 x 4 block and the cable is tight. Tighten the cable jam nut and remove the block. See Figure 26 on Page 11.
6. Place a 3" high block under the exact center of the rear lip of the deck.
7. Pull the hairpins and remove the cables from the rear lift arms.
8. Turn both blades perpendicular to tractor frame. The leading blade should have one "tip" near the center of left side deck lip. One "tip" on trailing blade should face the discharge chute.
9. Loosen nuts on eccentric bolt and pivot bolt and level the deck side to side by turning the eccentric adjusting bolt. The distance from floor to each blade tip should be within 1/8" of each other.
10. Adjust LIFT CABLE FERRULES in REAR LIFT BRACKETS until CABLES just slide over the rear arm pins. Reinstall flat washers and hairpins. Recheck level. See Figures 27 & 31.

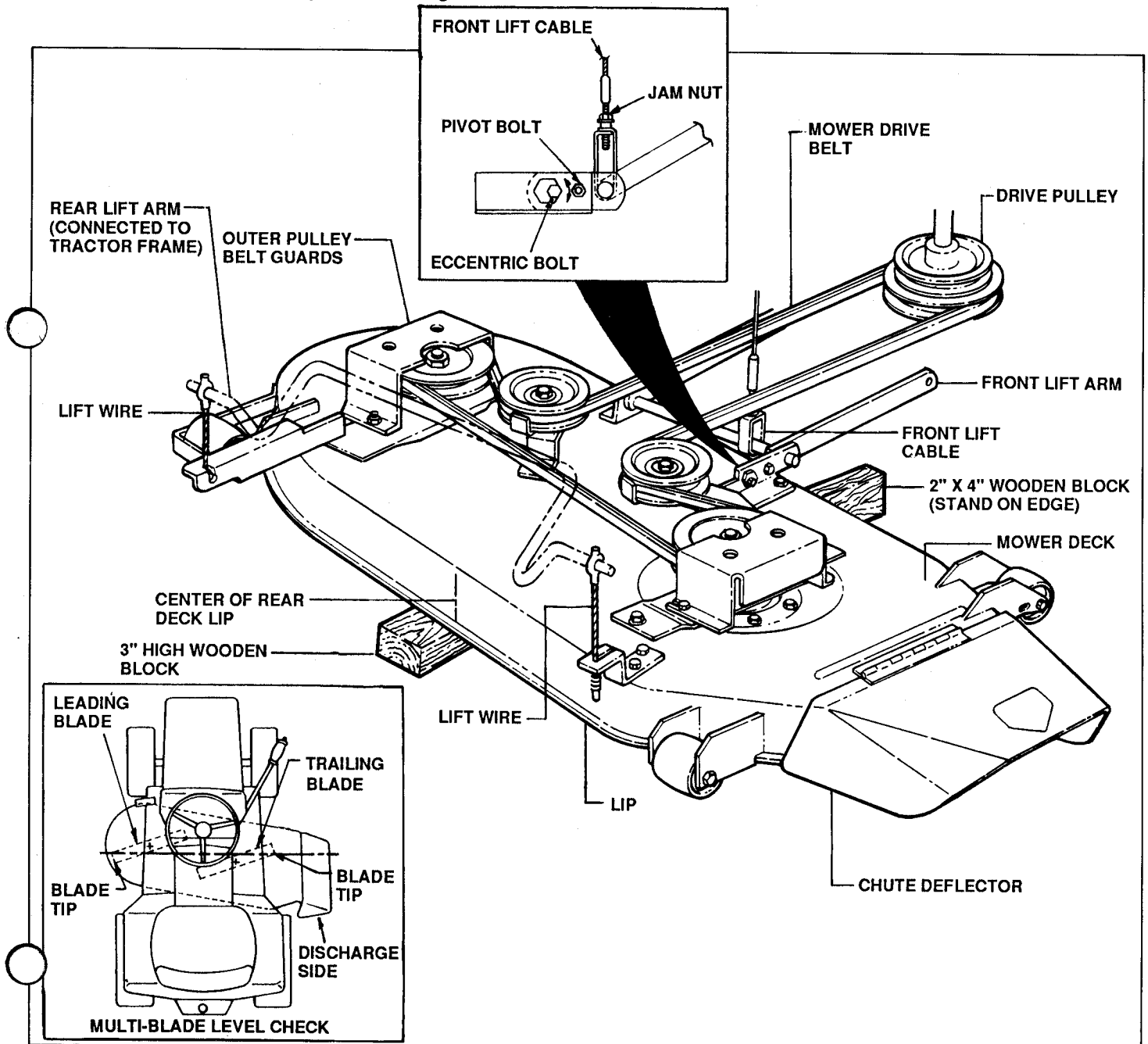

FIGURE 31

# SERVICE (Continued)

## DRIVE BELT SERVICE

To remove and replace the DRIVE BELT, follow steps 1 thru 11.

1. Raise mower hood and disconnect spark plug wire.
2. Lower MOWER DECK to lowest position.
3. Remove REAR COVER PLATE. See Figure 32.

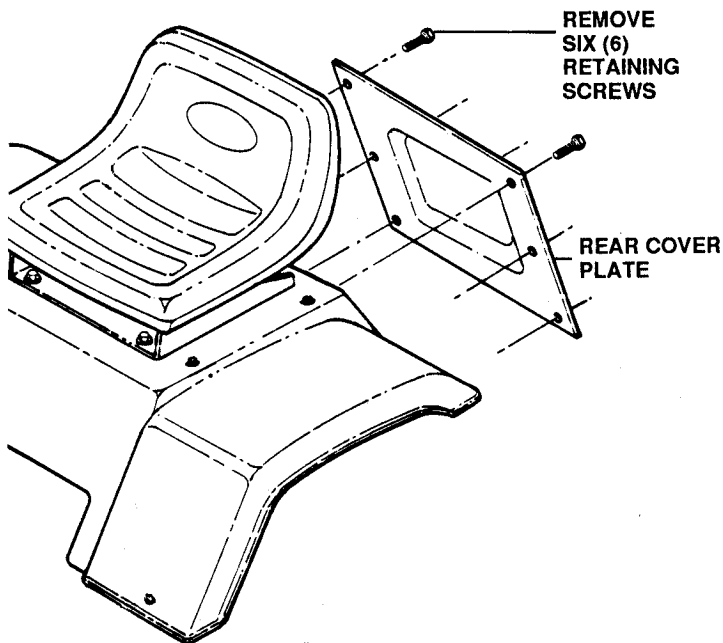

FIGURE 32

4. Depress CLUTCH/BRAKE PEDAL and lock into position by pulling PARKING BRAKE LEVER "UP".
5. Shift SPEED SELECTOR to 6th position.

### NOTE

ALTHOUGH IT IS POSSIBLE TO REMOVE AND REPLACE THE DRIVE BELT WITH THE MOWER DECK ATTACHED, IT IS RECOMMENDED THAT THE DECK BE REMOVED TO MAKE BELT INSTALLATION EASIER. SEE "REMOVING & INSTALLING MOWER", PAGES 11 & 12.

6. Disconnect IDLER SPRING. See Figure 33.

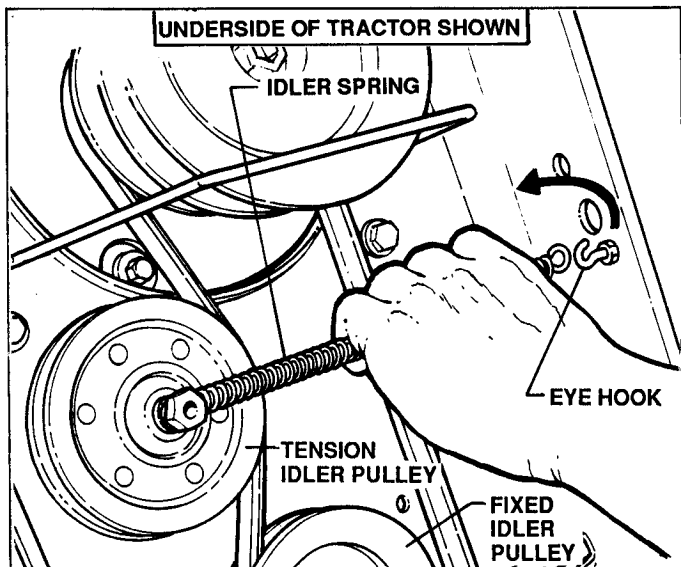

FIGURE 33

### CAUTION

THE IDLER SPRING IS UNDER TENSION. TO AVOID INJURY, USE CARE WHEN DISCONNECTING SPRING FROM EYE HOOK.

7. Remove hairpin from front of CONTROL ROD then lower CONTROL ROD. See Figure 34.

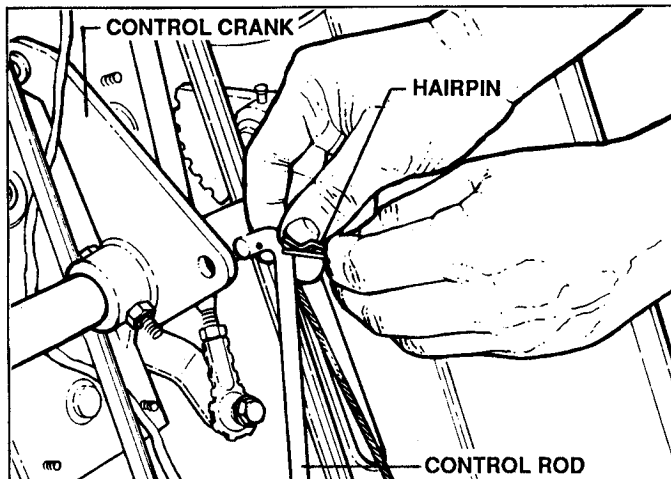

FIGURE 34

### NOTE

IF REMOVING/REPLACING DRIVE BELT WITH DECK ATTACHED, THEN REMOVE MOWER BELT FROM FRONT DRIVE PULLEY AT THIS TIME.

8. Remove DRIVE BELT from engine pulley by rotating MOWER DRIVE PULLEY and pulling down on DRIVE BELT at same time. Allow belt to remain on hub between pulleys at this time. See Figure 35.

### UNDERSIDE OF TRACTOR SHOWN

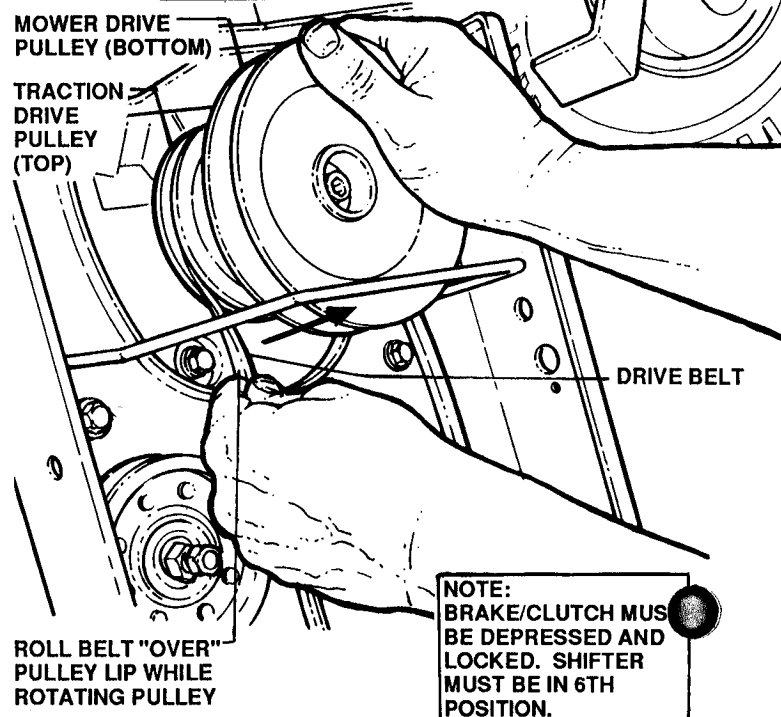

FIGURE 35

# SERVICE (Continued)

- Working at the rear of the tractor, rotate the DRIVE DISC while holding down on the DRIVE BELT until belt is clear of disc. See Figure 36.

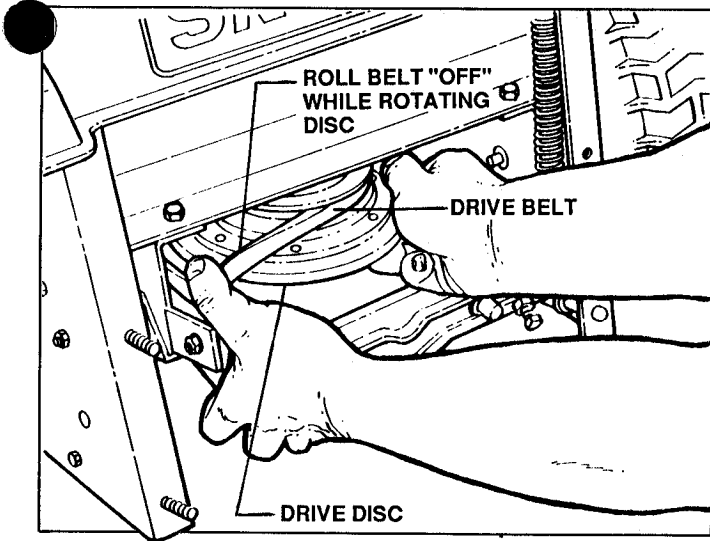

FIGURE 36

- Remove DRIVE BELT from pulley.
- Install DRIVE BELT in reverse order of above

### CAUTION

MAKE SURE THE BELT BEING INSTALLED IS ABOVE REAR LIFT ARM.

## TRACTION LOSS ADJUSTMENT

If rubber on driven disc ring wears enough to cause loss of traction, readjust the yoke stop (see Figure 37) to restore good contact. With engine "OFF" and drive shifted into "NEUTRAL", loosen the jamnuts and turn the bolt clockwise about two(2) turns. Check to see that rubber ring turns freely in the center or "NEUTRAL" groove - turn bolt in more if needed to achieve this, then secure bolt by tightening both jamnuts.

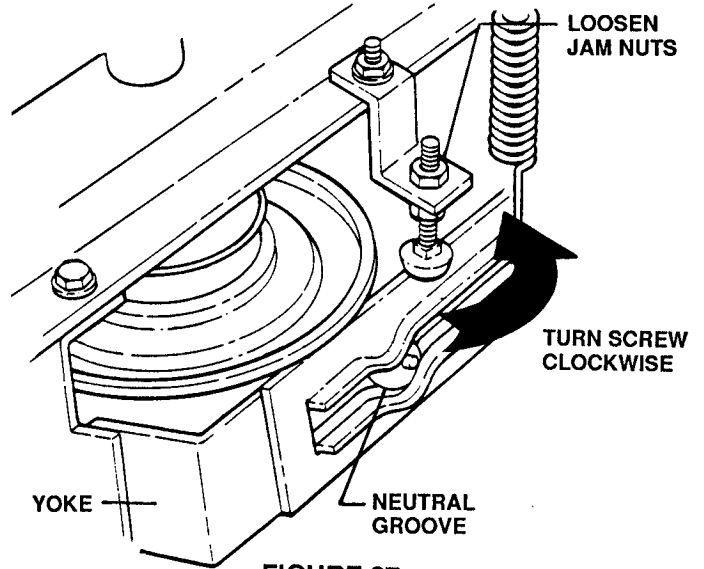

FIGURE 37

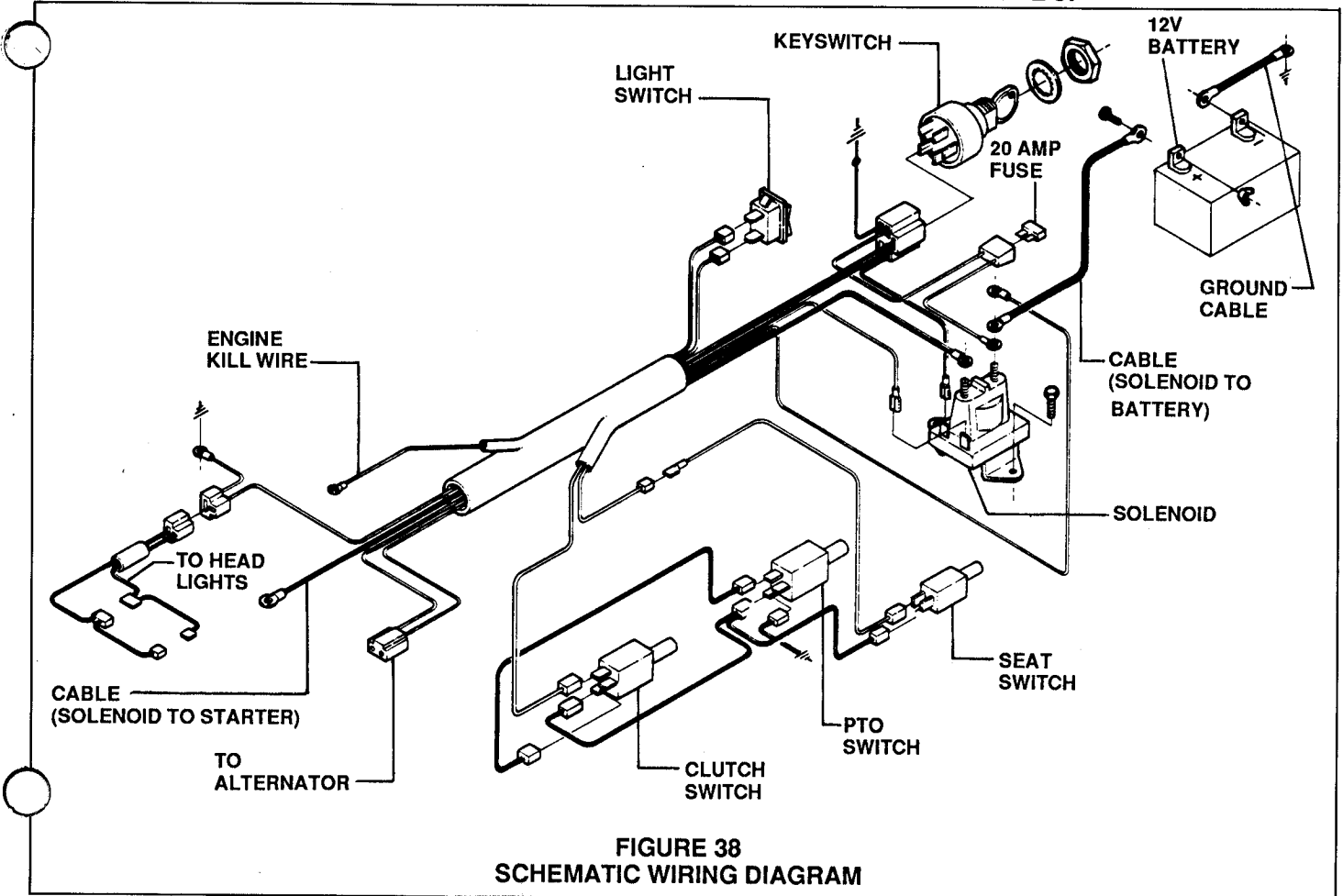

FIGURE 38  
SCHEMATIC WIRING DIAGRAM



# LT12D411TV & LT12D411B Series Tractors

## GENERAL SPECIFICATIONS

### DRIVE TRAIN

Friction Disc System provides 6 forward speeds and 1 reverse.

Brake: Drum and Band on Transmission

### TIRES

Front: 15 x 6.50 x 6  
Rear: 18 x 8.50 x 8

APPROX. WEIGHT 490 LBS.

### ENGINE

Refer to Engine Manufacturer's Manual for specifications.

### ELECTRICAL SYSTEM

Starter 12 volt gear drive  
Ignition Magnetron  
Alternator Tri-circuit

### FUEL SYSTEM

Fuel Capacity: 9 U.S. Quarts (2 1/4 U.S. GALS)  
Air Cleaner: Paper filter cartridge

## SNAPPER TOTAL PROTECTION

### FULL TWO-YEAR WARRANTY

- NON-COMMERCIAL USERS -

FOR TWO YEARS FROM THE ORIGINAL PURCHASE DATE OF THIS PRODUCT FOR YOUR NON-COMMERCIAL USE, SNAPPER POWER EQUIPMENT, THROUGH A SNAPPER DEALER, WILL REPAIR THE PRODUCT FREE OF CHARGE, IF IT DOES NOT WORK FOR ANY REASON.

RETURN THE PRODUCT TO A SNAPPER DEALER FOR REPAIR UNDER THIS WARRANTY.

YOU PROVIDE THE USUAL MAINTENANCE AS SPECIFIED IN THE OWNER/OPERATOR MANUALS.

THERE IS NO OTHER EXPRESS WARRANTY.

LIABILITY FOR INCIDENTAL AND CONSEQUENTIAL DAMAGES ARE EXCLUDED. SOME STATES DO NOT ALLOW THE EXCLUSION OF INCIDENTAL OR CONSEQUENTIAL DAMAGES, SO THIS EXCLUSION MAY NOT APPLY TO YOU.

THIS WARRANTY GIVES YOU SPECIFIC LEGAL RIGHTS, AND YOU MAY ALSO HAVE OTHER LEGAL RIGHTS WHICH VARY FROM STATE TO STATE AND COUNTRY TO COUNTRY.

### LIMITED WARRANTY

- COMMERCIAL USERS -

FOR NINETY (90) DAYS FROM THE ORIGINAL PURCHASE DATE OF THIS PRODUCT FOR YOUR COMMERCIAL USE, SNAPPER POWER EQUIPMENT, THROUGH AN AUTHORIZED SNAPPER DEALER, WILL REPAIR THE PRODUCT FREE OF CHARGE, IF IT IS FOUND TO BE DEFECTIVE IN MATERIAL OR WORKMANSHIP.

RETURN THE PRODUCT TO A SNAPPER DEALER FOR REPAIR UNDER THIS WARRANTY.

YOU PROVIDE THE USUAL MAINTENANCE AS SPECIFIED IN THE OWNER/OPERATOR MANUALS.

THERE IS NO OTHER EXPRESS WARRANTY.

IMPLIED WARRANTIES, INCLUDING THOSE OF MERCHANTABILITY AND FITNESS FOR A PARTICULAR PURPOSE, ARE LIMITED TO NINETY (90) DAYS FROM THE ORIGINAL PURCHASE DATE. SOME STATES DO NOT ALLOW LIMITATIONS ON HOW LONG AN IMPLIED WARRANTY LASTS, SO THE ABOVE LIMITATION MAY NOT APPLY TO YOU.

LIABILITY FOR INCIDENTAL AND CONSEQUENTIAL DAMAGES ARE EXCLUDED. SOME STATES DO NOT ALLOW THE EXCLUSION OR LIMITATION OF INCIDENTAL OR CONSEQUENTIAL DAMAGES, SO THE ABOVE EXCLUSION MAY NOT APPLY TO YOU.

THIS WARRANTY GIVES YOU SPECIFIC LEGAL RIGHTS, AND YOU MAY ALSO HAVE OTHER LEGAL RIGHTS WHICH VARY FROM STATE TO STATE AND COUNTRY TO COUNTRY.

PLEASE COMPLETE THE ATTACHED SNAPPER PRODUCT REGISTRATION CARD AND PROMPTLY MAIL IT TO SNAPPER POWER EQUIPMENT, McDONOUGH, GEORGIA 30253.

**SNAPPER POWER EQUIPMENT**

MANUAL #1-7107 (11/90)

McDonough, GA., 30253 U.S.A.



Printed in U.S.A.