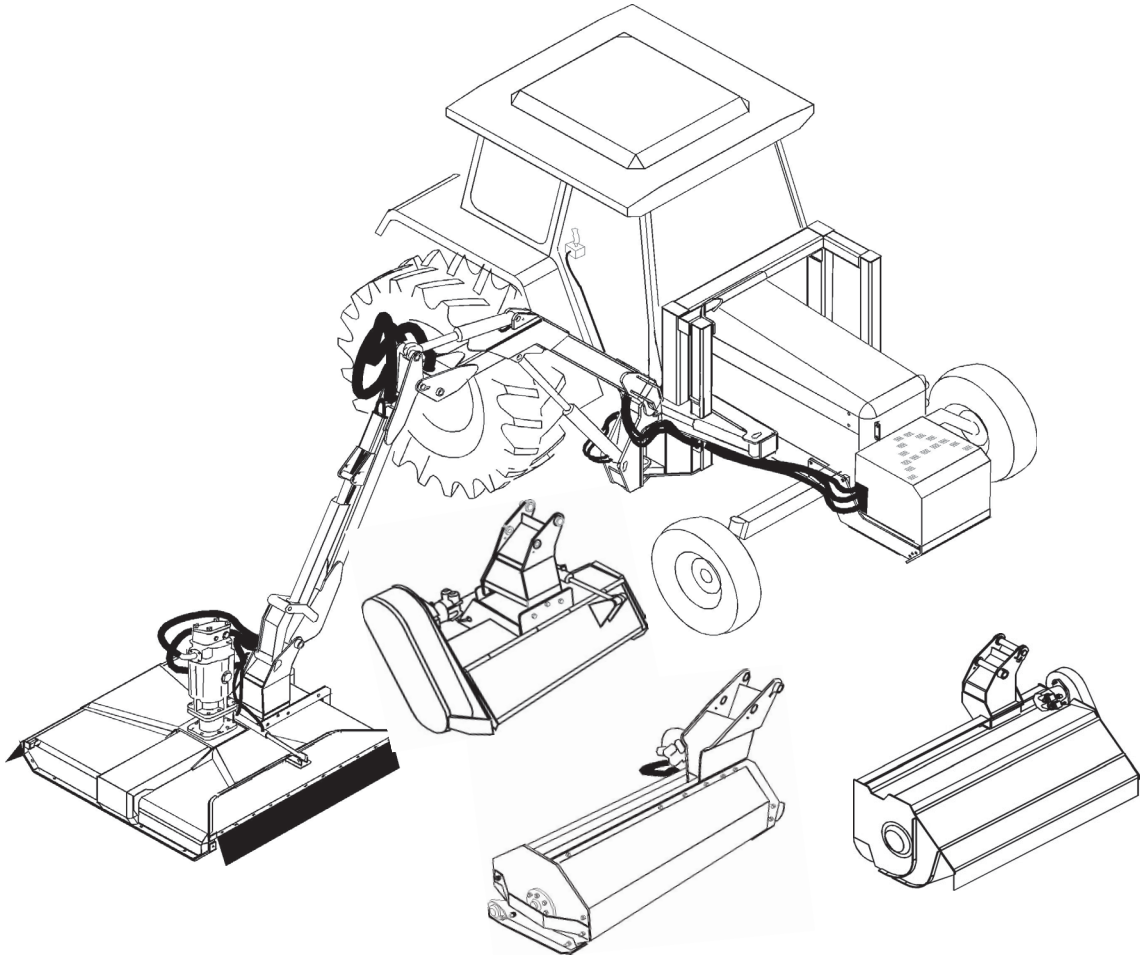




# A-BOOM

Assembly Instruction Manual  
John Deere 6615 and 7615



Tractors equipped with additional options, special equipment, tractor manufacturer modifications, new tractor models, or Customer alterations may prevent this Mount Kit from being properly mounted to the tractor. Alamo Group is not responsible for modifications to the MountKit to accommodate these differences.

**ALAMO INDUSTRIAL**

1502 E. Walnut  
Seguin, Texas 78155  
210-372-3551

Part No. 02980169

© 2003 Alamo Group Inc.



# TO THE OWNER/OPERATOR/DEALER

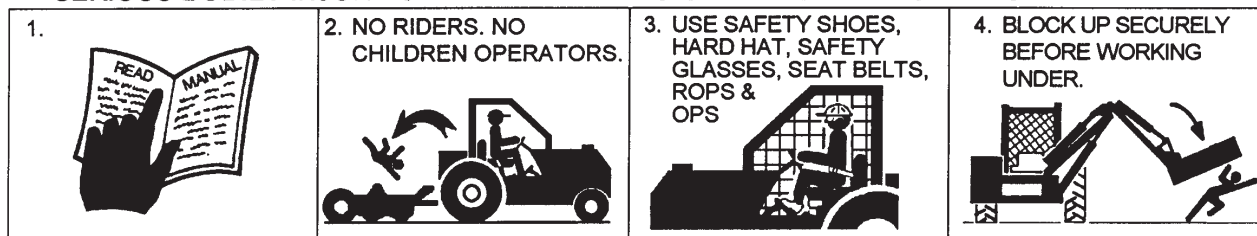
All implements with moving parts are potentially hazardous. There is no substitute for a cautious, safe-minded operator who recognizes the potential hazards and follows reasonable safety practices. The manufacturer has designed this implement to be used with all its safety equipment properly attached to minimize the chance of accidents.

**BEFORE YOU START!!** Read the safety messages on the implement and shown in your manual. Observe the rules of safety and common sense!



## DANGER

**FAILING TO FOLLOW SAFETY MESSAGES AND OPERATING INSTRUCTIONS CAN CAUSE SERIOUS BODILY INJURY OR EVEN DEATH TO OPERATOR AND OTHERS IN THE AREA.**



1. Study and understand Operator's Manuals, Safety Decals, and Instructional Decals for tractor and implement to prevent misuse, abuse, and accidents. Practice before operating in a confined area or near passersby.

- Learn how to stop engine suddenly in an emergency. Be alert for passersby and especially children

2. Allow no children on or near folding mower or tractor. Allow no riders on tractor or implement. Falling off may cause serious injury or death from being run over by tractor or mower or contact with rotating blades.

3. Operate only with tractor having Roll-Over Protective Structure (ROPS) and with seat belt securely fastened to prevent injury and possible death from falling off or tractor overturn.

- Personal Protective Equipment such as Hard Hat, Safety Glasses, Safety Shoes, & Ear Plugs are recommended.

4. Block up or support raised machine and all lifted components securely before putting hands or feet under or working underneath any lifted component to prevent crushing injury or death from sudden dropping or inadvertent operation of controls. Make certain area is clear before lowering or folding

5. Before transporting, put Lift Lever in detent or full-lift position. Install Transport Safety Devices securely on folding mowers. Put Booms securely in Transport Rest.

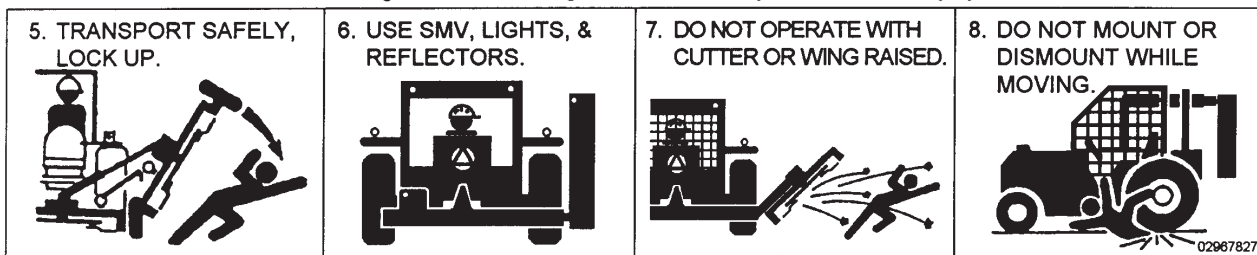
- Folding and Boom Mowers have raised center of gravity. Slow down when turning and on hillsides.

6. Make certain that SMV sign, warning lights, and reflectors are clearly visible. Follow local traffic codes.

7. Never operate with Cutting Head or Folding Section raised if passersby, bystanders, or traffic are in the area to reduce possibility of injury or death from objects thrown by Blades under Guards or mower structure.

8. Before dismounting, secure implement in transport position or lower to ground.

- Put tractor in park or set brake, disengage PTO, stop engine, remove key, and wait until noise of rotation has ceased to prevent crushing by entanglement in rotating parts which could cause injury or death.
- Never mount or dismount a moving vehicle. Crushing from runover may cause serious injury or death.



### WARRANTY INFORMATION:

Read and understand the complete Warranty Statement found in this Manual. Fill out the Warranty Registration Form in full and return it within 30 Days. Make certain the Serial Number of the Machine is recorded on the Warranty Card and on the Warranty Form that you retain. The use of "will-fit" parts will void your warranty and can cause catastrophic failure with possible injury or death.

# INTRODUCTION

## ABOUT THIS MANUAL:

The intent of this publication to provide the competent technician with the information necessary to perform the CORRECT Assembly to the Alamo Industrial Product. This will, in turn provide for complete customer satisfaction

It is hoped that the information contained in this and other Manuals will provide enough detail to eliminate the need for contact of the Alamo Industrial Technical Service Dept. However, it should be understood that many instances may arrive where correspondence with the Manufacturer is necessary.

## CONTACTING MANUFACTURER: (Please help us Help You! Before You Call! )

Alamo Industrial Service Staff Members are dedicated to helping you solve your problem, or your customer's service problem as quickly and efficiently as possible. Unfortunately, we receive entirely to many calls with only a minimum amount of information. In some cases, the correspondent has never gone out to look at the equipment and merely calls inquiring of the problems described to him by the operator or customer.

Most calls received by Alamo Industrial Service can be classified into approx. 6 general categories.

1. Hydraulic or Mechanical Trouble Shooting.
2. Request for Technical Information or Specifications.
3. Mounting or Fitting Problem.
4. Special Service Problem.
5. Equipment Application Problems.
6. Tractor Problem Inquiries.

## HOW YOU CAN HELP:

Make sure the call is necessary! Most of the calls received may not be necessary if the Dealer Service Technician would do the following.

1. Check the Service Information at your Dealership provided by Alamo Industrial, This would include, Service Bulletins, Information Bulletins, Parts Manuals, Operators Manuals, Assembly Manual or Service Manual, many of these are available via the Alamo Industrial Internet site ([www.Alamo-Industrial.Com](http://www.Alamo-Industrial.Com)). Attempt to diagnose or repair problem before calling.

2. If a call to Alamo Industrial is needed, Certain Information should be available and ready for the Alamo Industrial Service Staff. Such information as, Machine Model, Serial Number, Your Dealer Name, Your Account Number and Any other information that will be useful. This information is vital for the development of a prompt and correct solution to the problem. This will also help to develop a database of problems and related solutions, which will expedite a solution to future problems of a similar nature.

3. The technician may be asked to provide detailed information about the problem including the results of any required trouble shooting techniques. If the information is not available, The technician may be asked to get the information and call back. Most recommendations for repairs will be based on the procedures listed in the Service Manual / Trouble Shooting Guide and Information provided by customer.

## CONTACT ALAMO INDUSTRIAL:

Alamo Industrial, 1502 E. Walnut St. Seguin TX. 78155, Technical Service Dept. PH: 830-372-2708

# INDEX - ASSEMBLY INSTRUCTION

	Page
<b>Safety Section</b>	
<b>Operation Safety</b> .....	1
<b>Section 1</b>	
<b>Tools and Supplies Needed f/ Assembly</b> .....	1-2
Pre-Delivery Check List.....	1-3 to 1-5
<b>Section 2</b>	
Fill Left rear Wheel w/ calcium Chloride.....	2-2
Wheel Counter Weight Parts.....	2-2
Wheel Counter Weight Installation.....	2-3
<b>Section 3</b>	
Front Pump Drive Parts.....	3-2
Crankshaft Pulley Preparation.....	3-3
Pump Driveshaft Assembly.....	3-3
Pump Driveshaft Half, Shaft End.....	3-4
Pump Mount Plate.....	3-4 to 3-5
Pump Drive Shaft, Tube End.....	3-5
Pump Installation.....	3-5 to 3-6
Frame Rail Support Installation.....	3-7
<b>Section 4</b>	
Frame Rail Pre- Assembly.....	4-2 to 4-6
High Frame Parts.....	4-7
Frame Rail Pre-Installation.....	4-8 to 4-11
High Frame Pre-Installation.....	4-12 to 4-16
Tack Welding Frame Assembly.....	4-17 to 4-21
Remove Frame for Final Welding.....	4-21 to 4-23
<b>Section 5</b>	
Frame Rails Final Installation.....	5-2
Boom Rest Installation.....	5-3
Axle Strap Installation.....	5-4
Stabilizer Kit Installation.....	5-4
High Frame Installation.....	5-5 to 5-8
Tie Up Hoses to Tractor Frame (Stack valve Hoses).....	5-8
<b>Section 6</b>	
Hydraulic Tank Installation.....	6-2
Hydraulic Tank Counter Weight Installation.....	6-2
Hydraulic Tank Oil Level Sight Gauge.....	6-3
Hydraulic Tank Decal Installation.....	6-3
Cab Decal Installation.....	6-4

# INDEX - ASSEMBLY INSTRUCTION

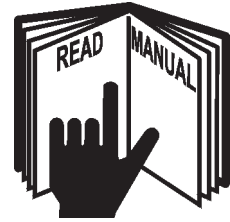
	Page
<b>Section 7</b>	
Cutter Motor Control Valve.....	7-2
Boom Installation / Boom Hoses.....	7-2 to 7-3
Pump / Tank Hose Installation.....	7-4 to 7-5
<b>Section 8</b>	
Control Handle Asy Installation (Mechanical Valve).....	8-2
"ON" "OFF" Switch Schematic (Standard Mechanical).....	8-3
"ON" "OFF" Switch Installation (Standard Mechanical).....	8-4
Control Valve Operation (Standard Mechanical).....	8-5
Hydraulic Hose Schematic (Standard Mechanical).....	8-6
Hydraulic Hose Control Circuit (Standard Mechanical).....	8-7 to 8-8
Remote Control Cable Installation (Standard Mechanical).....	8-8 to 8-11
<b>Section 9</b>	
Joystick Mount Parts.....	9-2
Install Joystick Mount to Seat.....	9-3
Install Joystick Controller to Seat Bracket.....	9-4
Tractor Floor Mat Removal.....	9-4
Wire Harness to Tractor Connections.....	9-5 to 9-6
Tractor Ignition Wire Connection.....	9-6
Connect Wire Harness to Joystick.....	9-6
Tractor Floor Mat re-Install.....	9-6
Tractor Cab Decal Installation.....	9-7
Connect Wire Harness to Control Valve.....	9-8 to 9-13
<b>Section 10</b>	
Attaching Flail Axe Head.....	10-2 to 10-3
Attaching Ditcher Head.....	10-4
Attaching Timbercat Head.....	10-5
Attaching X-Frame Square Head.....	10-6
<b>Section 11</b>	
Filling Hydraulic Tank w/Oil.....	11-2 to 11-3
<b>Section 12</b>	
Hydraulic Start Up Instructions.....	12-2
Post Assembly Check List.....	12-3
<b>Section 13</b>	
Boom Rest Plate Installation.....	13-2 to 13-3
Boom Swing Stop Installation.....	13-4

# NOTES

# SAFETY SECTION

# SAFETY

Read these assembly instructions through completely and understand them before proceeding with the assembly of the equipment.



A safe and careful operator is the best operator. Safety is of primary importance to the manufacturer and should be to the owner/operator. Most accidents can be avoided by being aware of your equipment, your surroundings, and observing certain precautions. The first section of this manual includes a list of Safety Messages that, if followed, will help protect the operator and bystanders from injury or death. Read and understand these Safety Messages before assembling, operating or servicing this Implement. This equipment should only be operated by those persons who have read the Manual, who are responsible and trained, and who know how to do so safely and responsibly.

The Safety Alert Symbol combined with a Signal Word, as seen below, is used throughout this manual and on decals which are attached to the equipment. The Safety Alert Symbol means: **“ATTENTION! BECOME ALERT! YOUR SAFETY IS INVOLVED!”** The Symbol and Signal Word are intended to warn the owner/operator of impending hazards and the degree of possible injury faced when operating this equipment..

**Practice all usual and customary safe working precautions and above all---remember safety is up to YOU. Only YOU can prevent serious injury or death from unsafe practices.**

## CAUTION!

The lowest level of Safety Message; warns of possible injury. Decals located on the Equipment with this Signal Word are Black and Yellow.



## WARNING!

Serious injury or possible death! Decals are Black and Orange.



## DANGER!

Imminent death/critical injury. Decals are Red and White. (SG-1)





# SAFETY

## PELIGRO!



Si no lee Ingles, pida ayuda a alguien que si lo lea para que le traduzca las medidas de seguridad. (SG-3)



**¡LEA EL INSTRUCTIVO!**

**READ, UNDERSTAND, and FOLLOW the following Safety Messages. Serious injury or death may occur unless care is taken to follow the warnings and instructions stated in the Safety Messages. Always use good common sense to avoid hazards.**

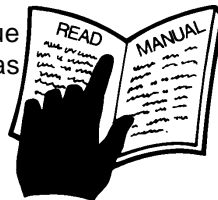
(SG-2)



## PELIGRO!



Si no lee Ingles, pida ayuda a alguien que si lo lea para que le traduzca las medidas de seguridad. (SG-3)



**¡ LEA EL INSTRUCTIVO!**

## WARNING!



Perform service, repairs and lubrication according to the maintenance section. Ensure the unit is properly lubricated as specified in the lubrication schedule and all bolts and nuts are properly torqued. Failure to properly service, repair and maintain this Implement in good operating condition could cause component failure and possible serious injury or even death. (SG-35)

## WARNING!



Operate this Equipment only with a Tractor equipped with an approved roll-over-protective system (ROPS). Always wear seat belts. Serious injury or even death could result from falling off the tractor--particularly during a turnover when the operator could be pinned under the ROPS. (SG-7)



## DANGER!



Never work under the Implement, the framework, or any lifted component unless the Implement is securely supported or blocked up to prevent sudden or inadvertent falling which could cause serious injury or even death. (SG-14)



## WARNING!



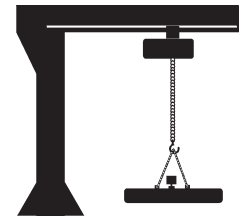
Use caution and wear protective gloves when handling sharp objects such as blades, knives, and other cutting edges. Be alert to worn component surfaces which have sharp edges. Sharp surfaces can inflict severe laceration injuries if proper hand protection is not worn. (SG-37)

# SAFETY

## WARNING!



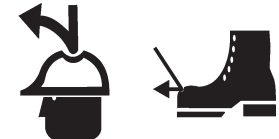
Many of the parts are heavy and require lifting assistance. Do not try to lift the heavy parts by yourself. Get help from another employee or from an overhead crane.



## WARNING!



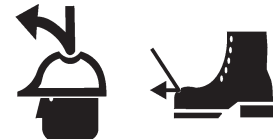
The operator and all support personnel should wear hard hats, safety shoes, safety glasses, and proper hearing protection at all times for protection from injury including injury from items thrown by the equipment. (SG-16)



## WARNING!



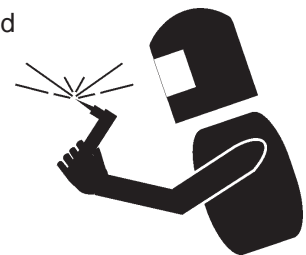
Always wear safety shoes with steel toes when working on this equipment. It is recommended that the safety shoes have metatarsal guards.



## WARNING!



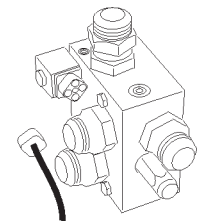
When welding use Welding hood with the appropriate OSHA required protective lens, welding apron, and welding gloves.



## DANGER!



Always disconnect the wire leads from the mower valve solenoid before performing service on the Tractor or Mower. Use caution when working on the Tractor or Mower. Tractor engine must be stopped before working on Mower or Tractor. The Mower Blades could inadvertently be turned on without warning and cause immediate dismemberment, injury or death. (SBM-12)



## DANGER!



Never run the tractor engine in a closed building or without adequate ventilation. The exhaust fumes can be hazardous to your health. (SG-23)

# SAFETY

**DANGER!**



Before starting the mower make sure the area is clear and the floor has been swept. The mower blade can throw objects several hundred feet. Thrown objects could damage property or cause severe bodily injuries even death.

**WARNING!**



Make certain that the "Slow Moving Vehicle" (SMV) sign is installed in such a way as to be clearly visible and legible. When transporting the Equipment use the Tractor flashing warning lights and follow all local traffic regulations. (SG-6)



**DANGER!**



Start tractor only when properly seated in the Tractor seat. Starting a tractor in gear can result in injury or death. Read the Tractor operators manual for proper starting instructions. (SG-13)



**DANGER!**



Do not operate this Equipment with hydraulic oil leaking. Oil is expensive and its presence could present a hazard. Do not check for leaks with your hand! Use a piece of heavy paper or cardboard. High-pressure oil streams from breaks in the line could penetrate the skin and cause tissue damage including gangrene. If oil does penetrate the skin, have the injury treated immediately by a physician knowledgeable and skilled in this procedure. (SG-15)



**WARNING!**



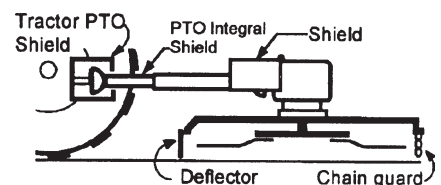
Always read carefully and comply fully with the manufacturers instructions when handling oil, solvents, cleansers, and any other chemical agent. (SG-22)



**DANGER!**



All Safety Shields, Guards and Safety devices including (but not limited to) - the Deflectors, Chain Guards, Steel Guards, Gearbox Shields, PTO integral shields, and Retractable Door Shields should be used and maintained in good working condition. All safety devices should be inspected carefully at least daily for missing or broken components. Missing, broken, or worn items must be replaced at once to reduce the possibility of injury or death from thrown objects, entanglement, or blade contact. (SGM-3)



# SAFETY

## DANGER!



**NEVER use drugs or alcohol** immediately before or while operating the Tractor and Implement. Drugs and alcohol will affect an operator's alertness and coordination and therefore affect the operator's ability to operate the equipment safely. Before operating the Tractor or Implement, an operator on prescription or over-the-counter medication must consult a medical professional regarding any side effects of the medication that would hinder their ability to operate the Equipment safely. **NEVER** knowingly allow anyone to operate this equipment when their alertness or coordination is impaired. Serious injury or death to the operator or others could result if the operator is under the influence of drugs or alcohol. (SG-27)



## DANGER!



Operate the Tractor and/or Implement controls only while properly seated in the Tractor seat with the seat belt securely fastened around you. Inadvertent movement of the Tractor or Implement may cause serious injury or death. (SG-29)

## WARNING!



**Engine Exhaust, some of its constituents, and certain vehicle components contain or emit chemicals known to the state of California to cause cancer and birth defects or other reproductive harm.** (SG-30)

## WARNING!



**Battery posts, terminals and related accessories contain lead and lead compounds, chemicals known to the state of California to cause cancer and birth defects or other reproductive harm. Wash Hands after handling.** (SG-31)

## WARNING!



Use extreme caution when getting onto the Implement to perform repairs, maintenance and when removing accumulated material. Only stand on solid flat surfaces to ensure good footing. Use a ladder or raised stand to access high spots which cannot be reached from ground level. Slipping and falling can cause serious injury or death. (SG-33)

## WARNING!



Avoid contact with hot surfaces including hydraulic oil tanks, pumps, motors, valves and hose connections. Relieve hydraulic pressure before performing maintenance or repairs. Use gloves and eye protection when servicing hot components. Contact with a hot surface or fluid can cause serious injury from burns or scalding. (SG-34)

## WARNING!



Avoid contact with hot surfaces of the engine or muffler. Use gloves and eye protection when servicing hot components. Contact with a hot surface or fluid can cause serious injury from burns or scalding. (SG-38)

# Section 1

## **A-BOOM**

### **TOOL REQUIREMENTS AND PRE-DELIVERY INSPECTION CHECKLIST**

# Assembly

## Tools, Supplies and Equipment Needed

Tools that are recommended to complete this assembly. There are number of different ways to do things, some items are recommended to make assembly easier but may not be required.

1. An over Head Hoist, the hoist (or Lift) should be a 2-1/2 ton capacity minimum. Hoist should be able to move and stop within fractions of an inch. Hoist should also have a 12 foot lift (Required).
2. Compressed Air, Air must be filtered and dry. A Safety air nozzle for blowing out Hoses and Fitting prior to assembly. (Required).
3. Complete Air Impact Sockets, 1/2" Drive and 3/4" drive (Recommended).
4. Torque Wrench, 400-ft lb. rating, can use a Torque Amplifier Wrench. (Required)
5. Complete Set of Hand Wrenches from 7/16" to 2" (Recommended).
6. Assortment of Screwdrivers, (Short ones and Long ones). (Required)
7. Electric Grinder or Air Grinder, Size according to needs (Required).
8. Burr Grinder, Electric or Air optional, for resizing Holes and removing Burrs from stamped metal or stamped holes. (Required)
9. Welder, capable of welding up to 3/8" material, Use experienced Welder Personel. (Required)
10. Flame Proof or flame retardant Material to Cover and protect Tractor finish and components during assembly. (Required)
11. A good fire Extinguisher on hand before any welding or grinding begins. (Required)
12. Clean dust free work area, clean Lint Free towels or wipes. Do not do any welding, use compressed Air or lay out any component unless area is clean. Material the size of a human hair can contaminate the Hydraulic System (Required).
13. A place to keep all Components separate and clean untill ready for them (Recommended)
14. Electrical Butt connectors and Electrical Pliers. (Required)
15. Paint Scraper to remove Paint before welding. (Recommended)
16. Floor Jack, 2-1/2 Ton capacity (Required)
17. An assortment of large C-Clamps (Required)

# A-BOOM PRE-DELIVERY INSPECTION CHECKLIST

**Pre-Operation Inspection:** After Assembly is complete. Check the following items before operating the unit to assure that they are properly assembled. (See following page 1-4 for component location)

## Safety Equipment:

- Operators Manual is with Unit.
- The Safety Decals are installed as listed in the Assembly Manual.
- Valve operation plate is installed.
- Operators cage or Tractor Cab is in place. (Item 1 page 1-5)
- Deflectors are installed on the Mower Head. (Item 2 page 1-5)
- Tractor Rops or Cab with seatbelts installed properly.

## Frame and Boom:

- Axle Plate Bolts are torqued to 240 ft. lbs. (Item 3 page 1-5)
- Boom Rest Axle Plate Bolts are torqued to 240 ft. lbs.
- Front Rail Bolts are torqued to 170 ft. lbs. (Item 17 page 1-5)
- Front Support Bolts are torqued to 240 ft. lbs. (Item 4 page 1-5)
- Hydraulic Tank mounting Pins / Bolts in place correctly.
- Boom Main Pins are torqued to 170 ft. lbs.
- King Pin Retaining Nut is properly locked in place.
- All Welds inspected to insure proper welds and locations.

## Hydraulic System:

- Oil Level in Hydraulic Tank is within the sight gauge. (Item 5 page 1-5)
- Hose connections are tightened according to specifications.
- Hoses do not have any kinks or twist in them.
- Front Pump Shaft adapter bolts are tight. (Item 6 page 1-5)
- Front Pump Shaft Coupler / Drive Shaft is lubricated and has an anti-seize compound on the Splines of Pump and Shafts. (Item 7 page 1-5)
- The Pump Drive Shaft has correct alignment.
- Suction Hose has no leaks or kinks.

## Rotary Mower Head:

- Skid Shoe Bolts are torqued to 120 ft. lbs. (Item 8 page 1-5)
- Spindle Housing Bolts are torqued to 400 ft. lbs. (Item 9 page 1-5)
- The Spindle Housing is properly lubricated. (item 10 page 1-5)
- Motor Bolts are torqued to 120 ft. lbs. (Item 11 page 1-5)
- Blade Carrier (Bar) Bolts torque to 400 ft. lbs. (Item 12 page 1-5)
- All Blade Bolts are torqued, the retainings Pins are in place. (item 13 page 1-5)
- Blades Swing freely. (Item 14 page 1-5)

# A-BOOM PRE-DELIVERY INSPECTION CHECKLIST

**Pre-Operation Inspection:** Check the following items before operating the unit to assure that they are properly assembled. (See following page 1-4 for component location)

## Flail Mower Head:

- \_\_\_ Skid Shoe Bolts are torqued to 120 ft-lbs (Item 15 page 5)
- \_\_\_ Motor Bolts are torqued to 120 ft-lbs
- \_\_\_ Belt Alignment & tension adjustment is correct
- \_\_\_ Cutter shaft bearings are properly lubricated
- \_\_\_ Roller bearings are properly lubricated (Item 16 Page 5)
- \_\_\_ Blades swing freely

## Tractor Mower Operation Inspection:

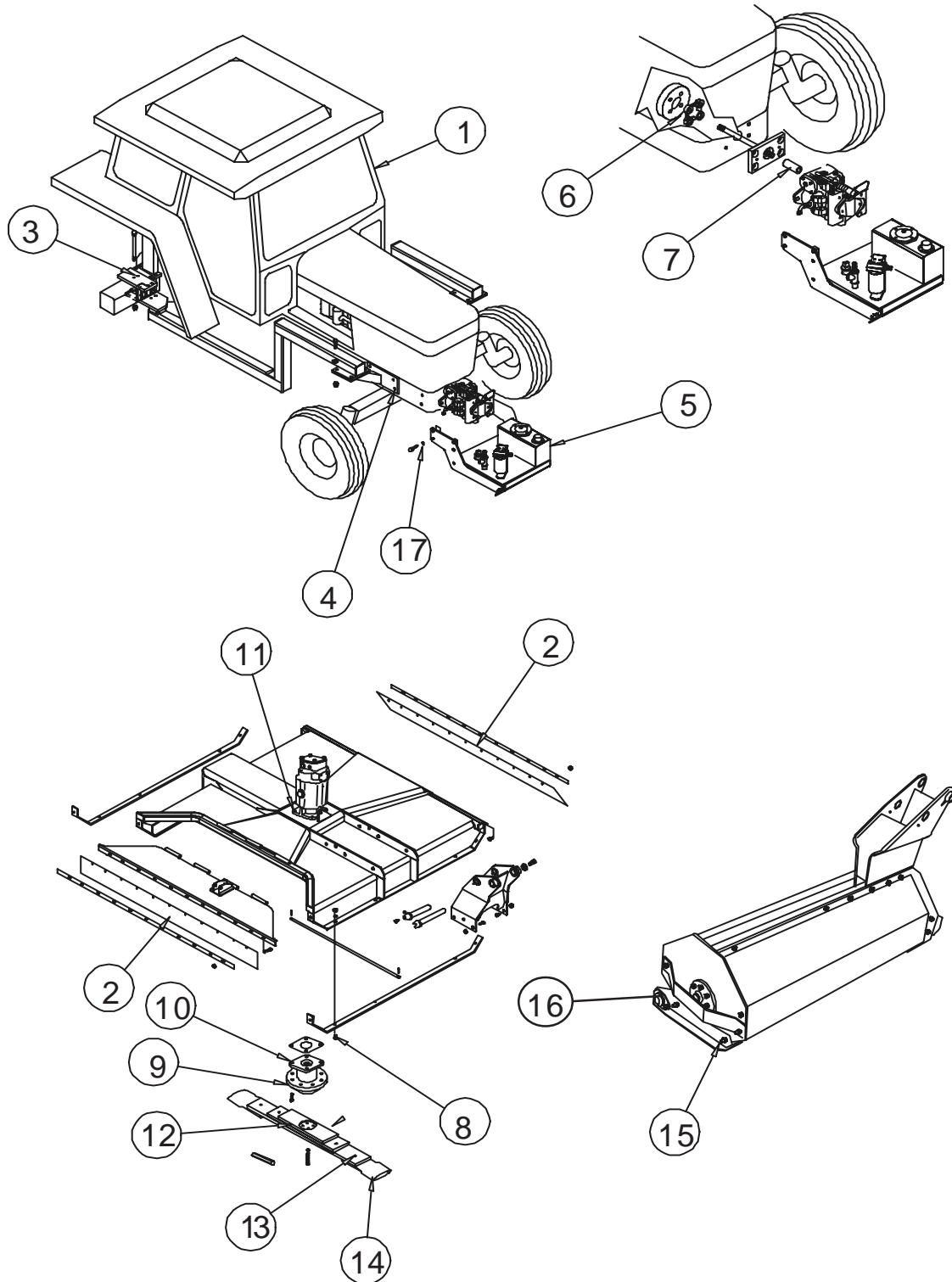
- \_\_\_ Using all Safety precautions, operate the Tractor and Mower unit for 30 minutes and while the unit is running check the following items: **Note!** Only make adjustments after the mower has been turned off and all motion has stopped and all hydraulic pressure has been relieved.
  
- \_\_\_ No Hydraulic oil leaks at the hose connections
- \_\_\_ Operate the boom and mower head throughout its full range of motion and check for hose's rubbing, pinching, or kinking.
- \_\_\_ Make sure the Return Filter Gauge is reading in the Green after Oil is warm.
- \_\_\_ Check the function of the Mower Head On-Off Valve and switch for proper function
- \_\_\_ Make sure that the tractor will not start with the mower on-off switch in the on position.
- \_\_\_ Check the Blade Rotation for the Rotary Mower Head to make sure it is turning Clockwise looking from the top of the mower deck.
- \_\_\_ Make sure the control valve boom movements agree with the valve operation decal.
- \_\_\_ Make Sure Boom Movement operates as expected and is smooth and under control (no air in the control system)
- \_\_\_ Look for any unusual or excessive noise or vibrations.
- \_\_\_ Make sure all Wheel Weights are installed, Tires are Filled with liquid and Counter Weight is installed
- \_\_\_ Make sure the left rear wheel of the tractor stays on the ground when the boom is fully extended horizontally with 200 lbs. placed on the outside of the mower head.

## Post-Operation Inspection:

- \_\_\_ Check that the oil in the hydraulic tank has not turned milky in color or has foam on top.
- \_\_\_ Check that there are no loose fasteners or hardware.



# Tractor - Mower Component Location For Check List



# Section 2

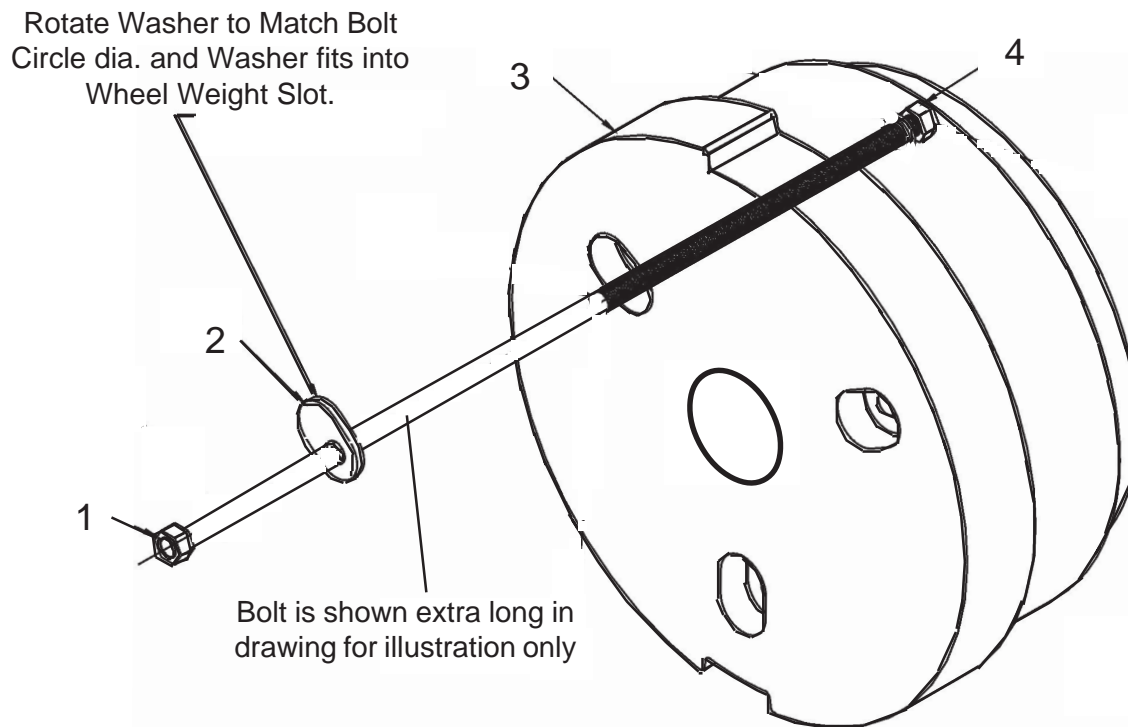
## **A-BOOM**

### **Wheel Weight Installation**

# Rear Wheel Counter Weight

## Fill Left Rear Wheel with Liquid:

The Left Rear Wheel must be filled with liquid. Alamo Industrial recommends a Calcium Chloride Water Mixture. The recommended Ratio of a 30 / 70 mix (30% Calcium Chloride and 70% Water), this mixture will add weight at about 10.5 lbs per gallon. Follow the Mixture procedures furnished by the Manufacturer of the Brand of Calcium Chloride that you are using. It is also recommended that a trained person installs the calcium Chloride. Calcium Chloride must be added in addition to the Steel Wheel Weight and the Counter Weight that hangs on the Left Side. It is Not recommended to use straight Water in the Wheel as this would not provide protection against freezing. A 30/70 Calcium Chloride Water mixture provides anti-freeze to approx -50 deg. F. below 0.



**Figure 1**

Item	Part No.	Qty	Description
1	02979603	3	Hex Head Bolt, 7/8" NC X 16"
2	02971569	3	Wheel Weight Washer, Special
3	02970758	1	Wheel Weight Casting, 1400 lbs.
4	5JRC1490	3	Locknut, Top Lock 7/8" NC

Note: some Older Units used a All Thread Rod with Hex Nuts Lock Nuts, with Flat Washer and Lock washer. This was replaced with the Bolt Type shown above. These Bolt and Nut combinations will replace the old All Thread type.

## Rear Wheel Counter Weight

### Installing Wheel Weight

1. This Wheel Weight is 1400 lbs. Always use caution when working with it.

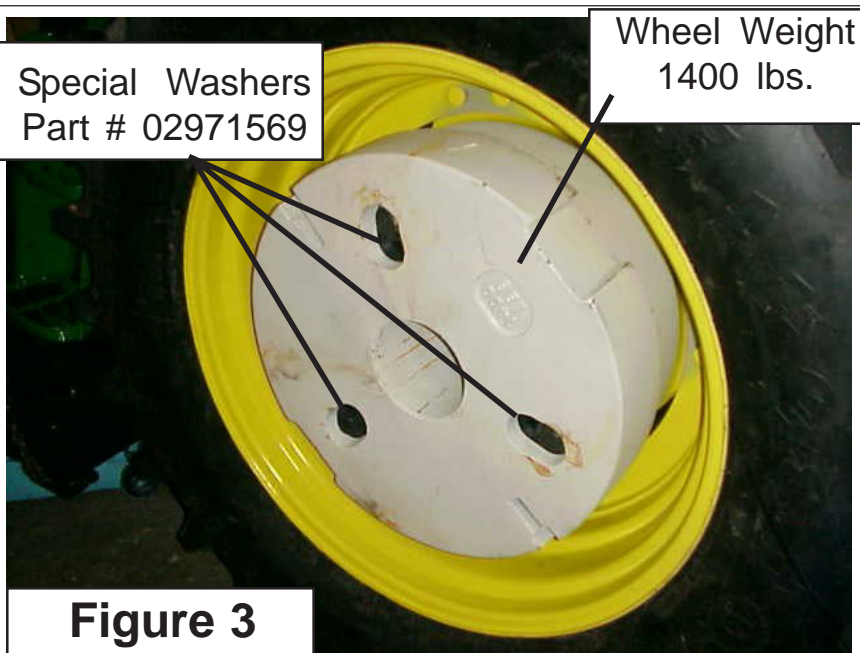
2. Locate the three Holes in LH Rear Wheel. Make sure these holes are 15/16" dia. if not, they must be reamed out.

3. Lift Left Rear Tractor Wheel till it just clears the ground. This will allow the Wheel to be rotated when aligning mounting holes for Weight.

4. Using a forklift, lift Wheel Weight into Wheel. When Wheel Weight is centered in Wheel Secure Forklift and Set Parking Brake on Forklift. Insert one of the three bolts through Weight and Wheel (Rotate Wheel to align holes if needed). Install a Hex Lock Nut on inside. Insert the other two Bolts through Weight and Wheel and start the other two Locknuts. Do not tighten yet. (See Figure 2)

5. Looking at the outside make sure the three special Washers (Figure 1 Item 2) are aligned with the Slots in the Wheel Weight. Tighten the three Bolts now. You will need an assistant to hold the other Side while you are tightening the Bolts. While tightening Bolts, check to make sure the three special washers are seated correctly. If these Bolts are tightened and washer are not seated into the recess on Wheel Weight, damage will occur. (See Figure 3)

6. Remove forklift away from Wheel and Weight. Re-check tightness of Wheel Weight retaining Bolts. Bolts should torque to 500 ft. lbs.



# NOTES

Empty space for notes.

# Section 3

## **A-Boom**

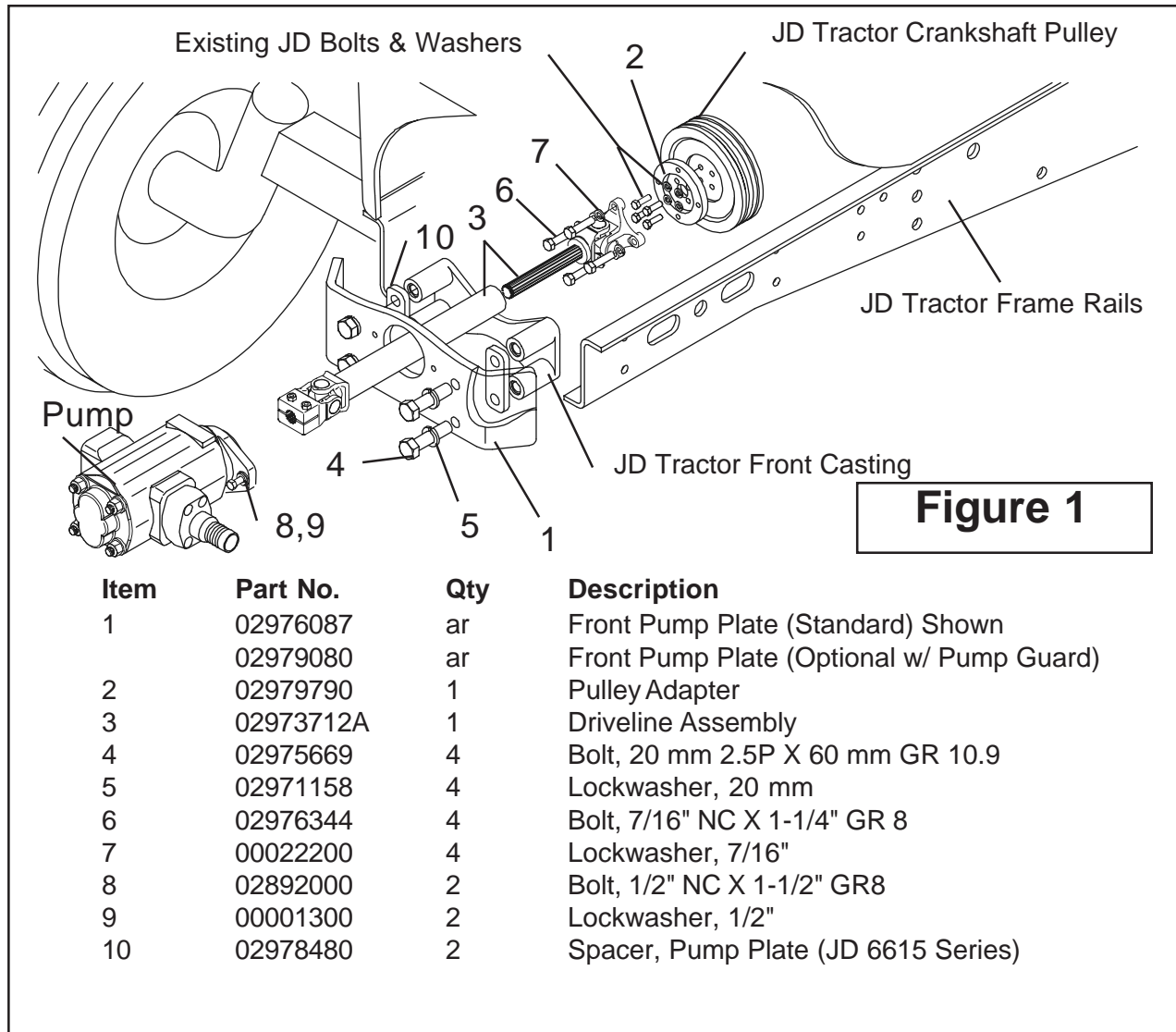
### **Front Pump & Drive Shaft Installation**

# Pump / Drive Assembly Instructions

## Installing Pump, Pump Drive Components and Hydraulic Tank:

This Section covers the installation of Pump Drive Components, Pump Assembly and the Hydraulic Tank. Some precautions must be followed during the Assembly Process and before unit is ever started for the first time.

1. Tractor must be disabled to prevent accidental engine start and prevent damage to components.
2. All Fittings, Hose, Cylinders, Tank must be kept plugged at all times, No part of the Hydraulic System can be left open at any time
3. All Tools, Work Area, Components and Workers Hands must remain Clean when working on any part of the Hydraulic System.
4. All components should be rechecked for tightness at least twice, Hose routing also double checked.



Item	Part No.	Qty	Description
1	02976087	ar	Front Pump Plate (Standard) Shown
	02979080	ar	Front Pump Plate (Optional w/ Pump Guard)
2	02979790	1	Pulley Adapter
3	02973712A	1	Driveline Assembly
4	02975669	4	Bolt, 20 mm 2.5P X 60 mm GR 10.9
5	02971158	4	Lockwasher, 20 mm
6	02976344	4	Bolt, 7/16" NC X 1-1/4" GR 8
7	00022200	4	Lockwasher, 7/16"
8	02892000	2	Bolt, 1/2" NC X 1-1/2" GR8
9	00001300	2	Lockwasher, 1/2"
10	02978480	2	Spacer, Pump Plate (JD 6615 Series)

## Installing Pump Drive Components:

1. Remove Front Cover (See Figure 2), Remove the 4 plastic plugs shown in figure 1 and discard them, they will not be needed. Remove the 2 Allen Head Cover Retaining Bolts. After removal, this front cover will not be used. The front Casting will have a Driveline Hole in it. (See Figure 3). This will be the same on 2 WD or 4 WD.

# Pump / Drive Assembly Instructions

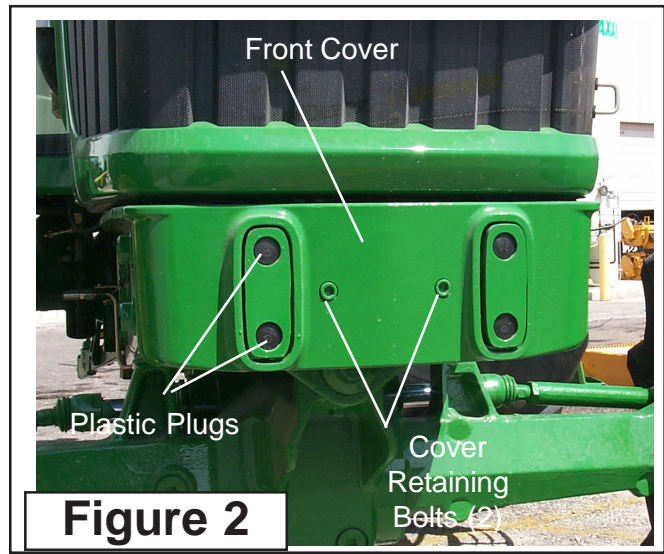
## Installing Pump Drive

### Components:

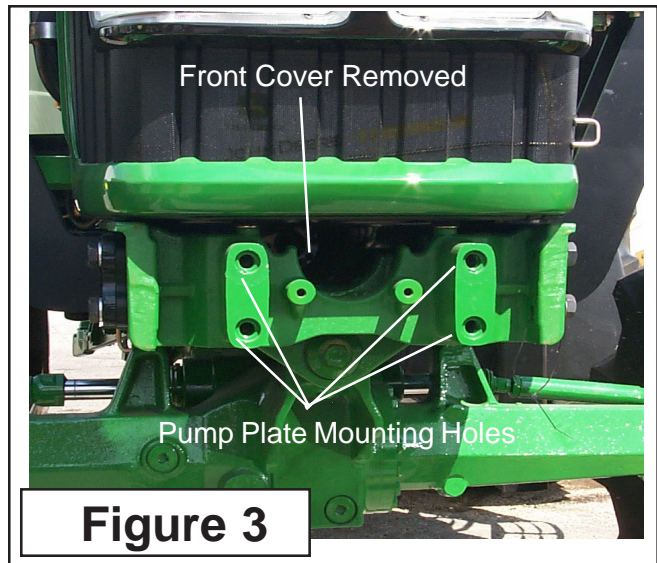
2. Access to Crankshaft Pulley. The Factory Crankshaft Pulley will not need to be removed. The Pulley Adapter will be bolted to the Factory Crankshaft Pulley.

3. Install Pulley Adapter. The Pulley adapter to be used is a round plate with 4 threaded holes and four non-threaded holes in it. Notice this pulley adapter will not have a center hole in it (**See Figure 4**). The Non-treaded holes are used to mount the Adapter to the Pulley using bolts # 02979791 (10mm 1.5 P X 35mm Gr.10.9) & Lockwasher # 00755954 (10 mm). Do not use longer bolts to mount Pulley Adapter to Pulley than is supplied with mounting kit.

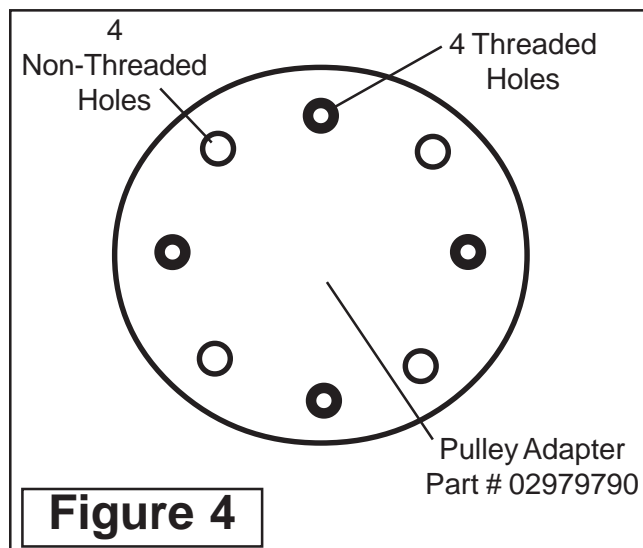
4. Driveshaft Assembly. The drive shaft is a two piece Assembly, an inner and outer shaft assembly (**See Figure 5**). The Shaft End has a four bolt flange yokes on it that connect to the Crankshaft Pulley Adapter. The Tube end has a splined clamp yoke on it that connects to the Pump. This Drive Shaft connects to the Pulley Adapter. Note that the Universals of the Driveshaft are in time. When installed in tractor they should be in time as shown, both Yokes the same.



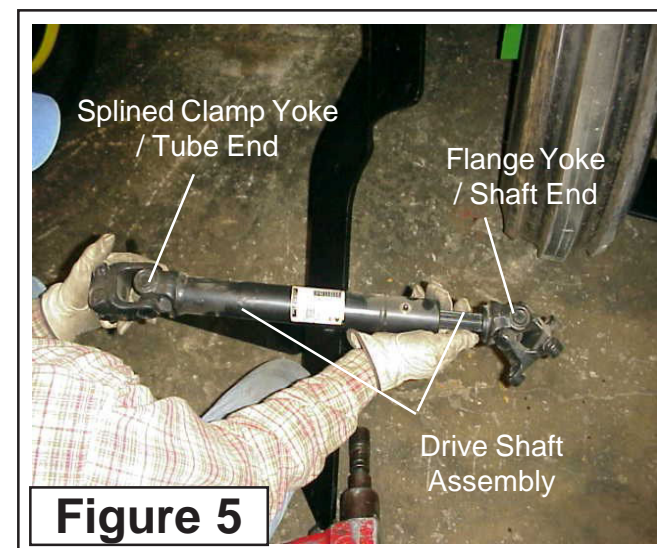
**Figure 2**



**Figure 3**



**Figure 4**



**Figure 5**

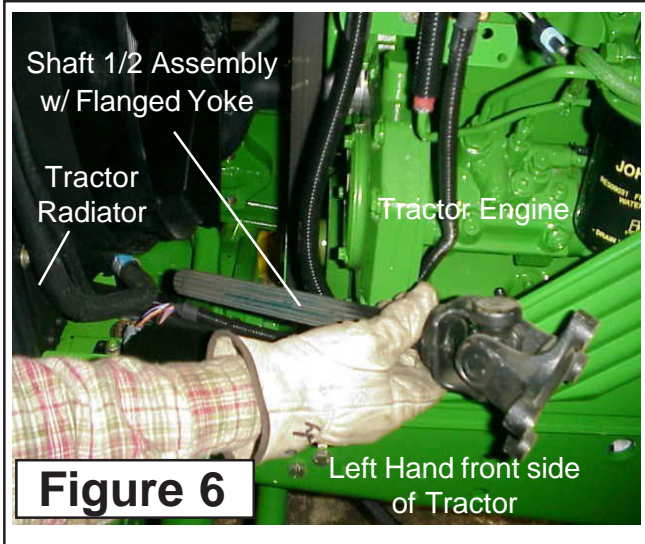


# Pump / Drive Assembly Instructions

## Installing Pump Drive Components: (continued)

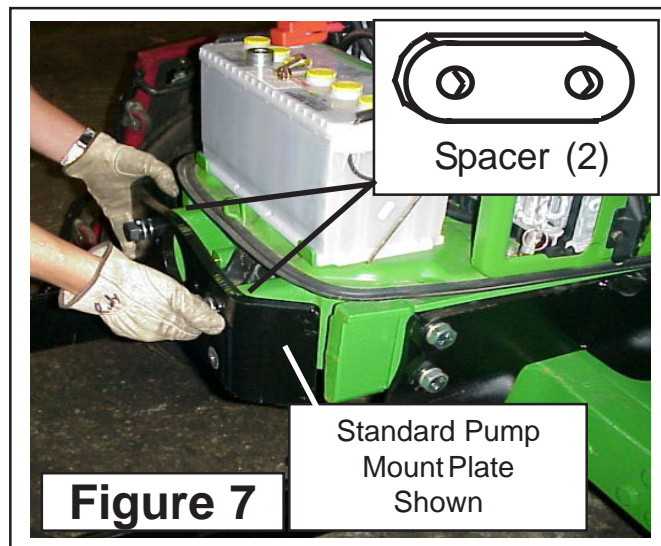
### 6. Install Shaft End of Driveline / Engine end.

Install the Shaft 1/2 Assembly w/ Flanged Yoke into the Engine compartment of Tractor, install it from the LH front Side down and under radiator. (See **Figure 6**). This needs to be installed this way because the Flange Yoke will not go through the Crankshaft access hole in the front of the Tractor (See **Figure 3**). Bolt the Flange Yoke to the Pulley Adapter using the four 7/16" X 1-1/4" Bolts (Part # 02976344), use the four Lock Washers (Part # 00022200), put Locktite on the threads of the Bolts and install them into Pulley Adapter. To Tighten these four Bolts, use a long extension and go through the front Crankshaft Pulley access hole in front of Tractor. Do Not use bolts longer than 1-1/4" long, longer bolts will damage Crankshaft Pulley.



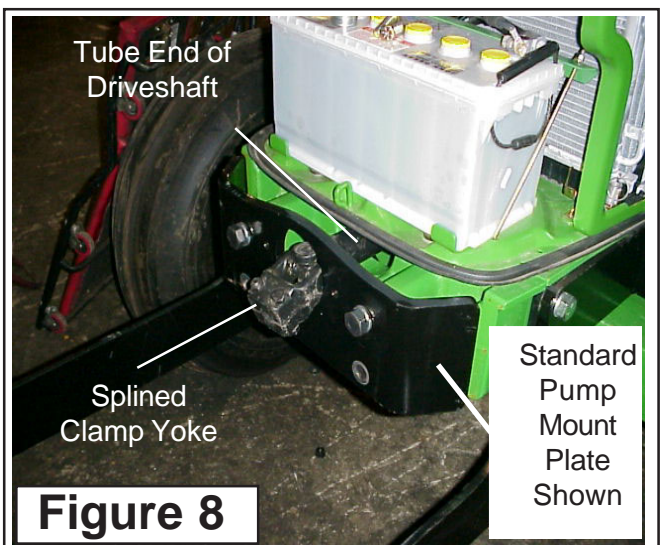
### Installing Pump Mount Plate & Tube End of Driveshaft:

1. Install Pump Mount Plate. Install Front Pump Mount Plate # 02976087 standard mount plate (See **Figure 7**) or # 02979080 optional Pump Mount Plate w/ Pump Guard built on. (Not Shown) use the 2 Spacers on the JD 6615 Series, Do not install Pump Mount Plate without using these Spacers. The Spacers are for Tractor Hood Clearance. Insert the 4 bolts and lock washers into Pump Mount Plate and spacers (See **Figure 7**), tighten them to required Torque (See Bolt Torque Chart).



2. Driveline timing means the universal joints are both the same position when driveline half is slid together. If they are not timed, it will decrease the life of the universal joint and in some cases could cause a vibration. (See **Figure 5 on previous page**)

3. Install Tube End of Driveline / Pump End. Slide the Tube half of driveshaft through Pump Mount Plate and Tractor Crankshaft Access Hole (See **Figure 8**). You will have to align the Universals when doing this (time the Driveshaft). Slide the two together where the Universal are in time (See **Figure 5 on previous page**), this will help the driveshaft to operate smoothly.



# Pump / Drive Assembly Instructions

## Installing Pump Mount Plate & Tube End of Driveshaft: (continued)

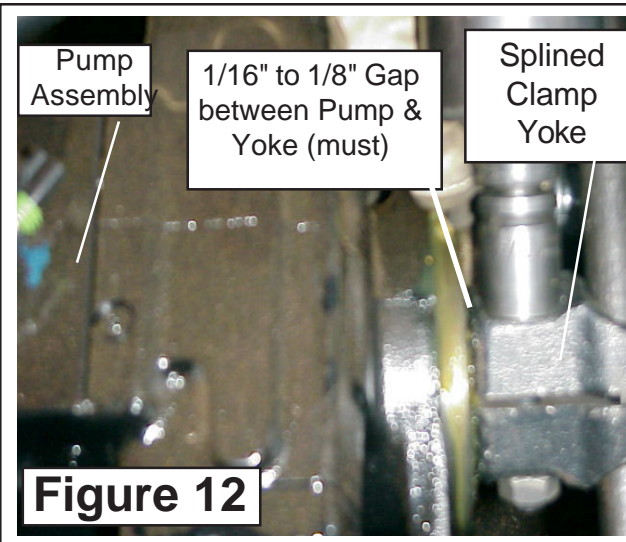
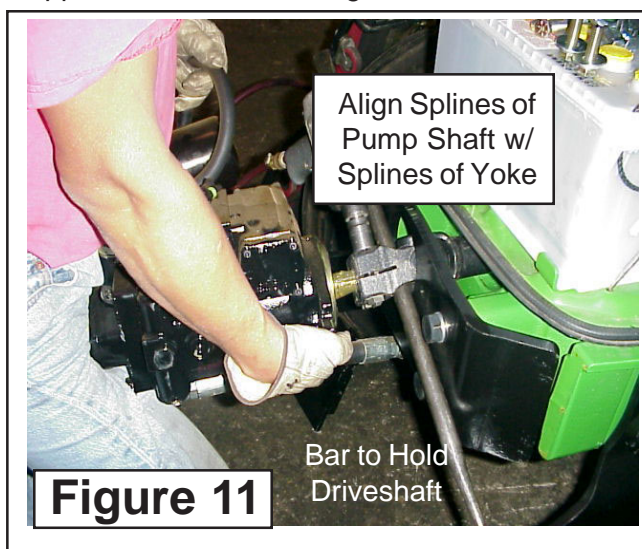
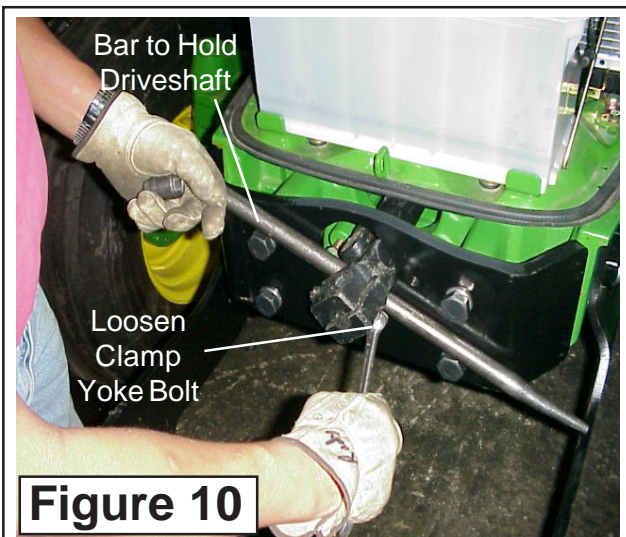
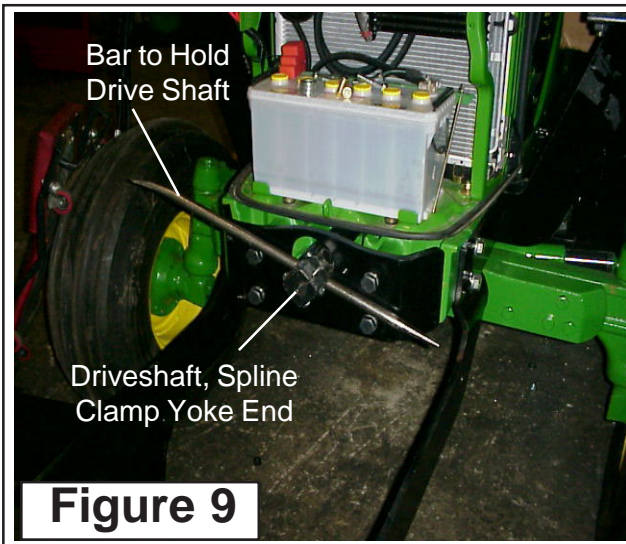
4. Loosen Splined Clamp Yoke. Insert a bar through the Yoke to hold Driveshaft up and to help loosen the Bolts in the clamp Yoke (**See Figure 10**). This can be loosened with a hand Wrench or a Socket whichever is easier for you (**See Figure 10**). Some times it is easier to test fit the Tube End of Driveshaft to the Pump while the Pump is on the bench.

### Installing Pump:

1. Install Pump into Splined Clamp Yoke. Slide the Pump Splined Shaft into the Spline Clamp Yoke (**See Figure 11**). Leave the Bar stuck in through the Yoke as shown, this helps to stabilize the Yoke as you slide Shaft into the Yoke. Once Pump is slid into the Splined Yoke, keep the Pump supported; DO NOT let the Pump hang on the Yoke unsupported.

2. Pump / Driveshaft Yoke Gap Adjustment. After sliding Pump Shaft into Splined Clamp Yoke, the Pump and Yoke must be slid apart far enough to allow for a 1/16" to 1/8" Gap between them. The Yoke edge cannot touch the Pump Housing; it will damage the Housing and the Yoke if it does. This is a very critical adjustment (**See Figure 12**).

3. Tighten Clamp Yoke. After Gap between Yoke and Pump has been adjusted tighten the Bolts & Nuts on the Clamp Yoke (**See Figure 12 & 13**). Check Pump to Yoke Gap once more. Keep Pump Supported do not let it hang on Yoke.



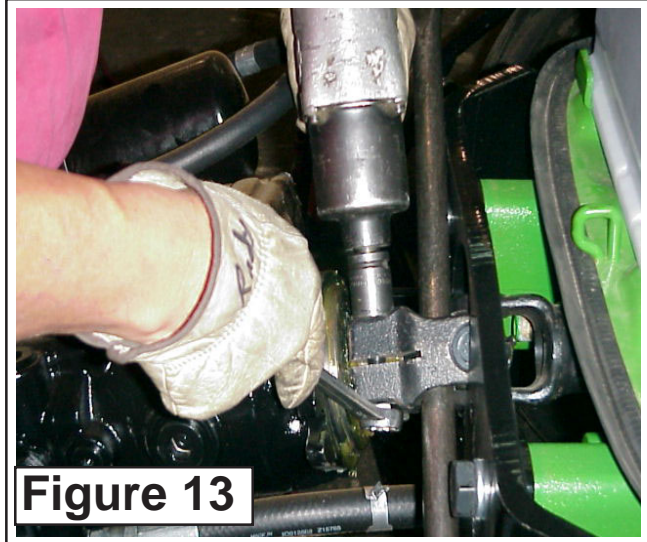
# Pump / Drive Assembly Instructions

## Installing Pump: (continued)

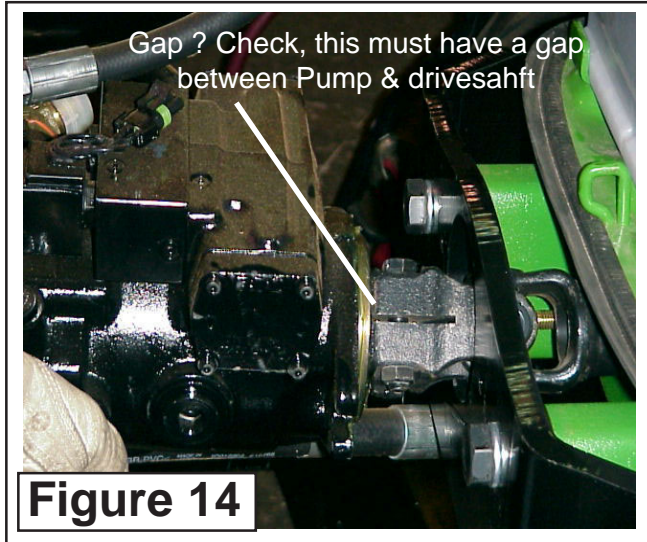
5. Mount Pump to Pump Plate. Remove the Bar that is slid through the Driveshaft Yoke and push the Pump inward (**See Figure 14**). This will make the two piece Driveshaft slide together allowing the Pump to be pushed towards the tractor. Do this until the Pump is against the Pump Plate (**See Figure 15**).

6. Install Pump Mounting Bolts. While holding in on the Pump (**See Figure 15**) start the two Pump Retaining Bolts. Make sure both Bolts are started well before you stop supporting pump. The Bolts should be snugged until pump sits level before you stop supporting it (**See Figure 16**). Let go of the Pump, it may slide back some and leave a slight gap between Pump and Mounting Plate (**See Figure 16**).

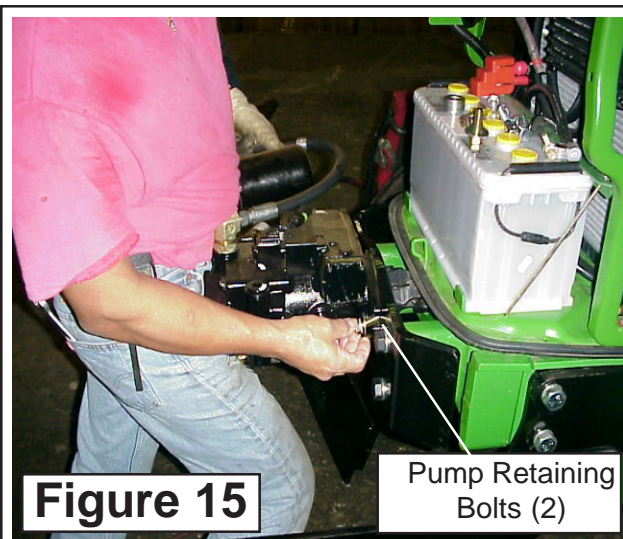
7. Tightening Pump Mounting Bolts. There is a shoulder on Pump Flange that must line up through hole in Pump Mounting Plate (**See Figure 14**), if the Pump is slid back as in figure 14 try to push it inward until it is against Pump Mount Plate as shown (**See Figure 15**). Slowly and alternating from Left to the Right side, tighten the Pump mounting bolts until they are tight. **DO NOT FORCE** Pump through Pump Mount Plate, if it will not freely slide in check for a problem of some kind. Excess force could damage Pump Housing. (See Figure 16). Do Not remove any Plastic caps from Pump inlet or outlet at this time, keep all openings plugged and sealed to keep them clean.



**Figure 13**

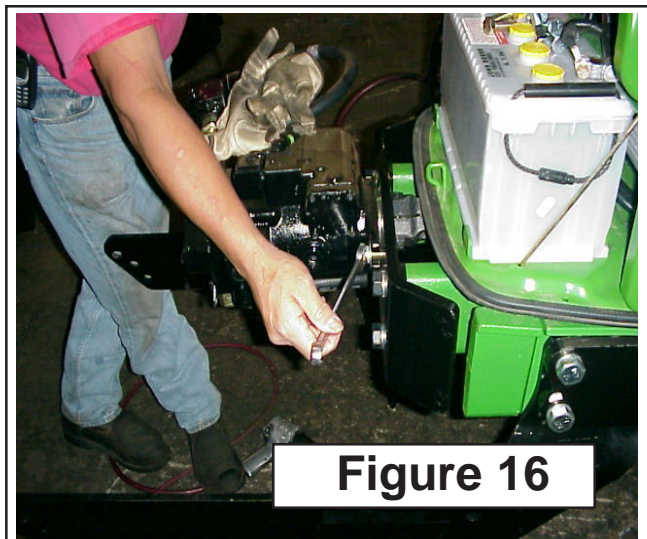


**Figure 14**



**Figure 15**

Pump Retaining Bolts (2)



**Figure 16**

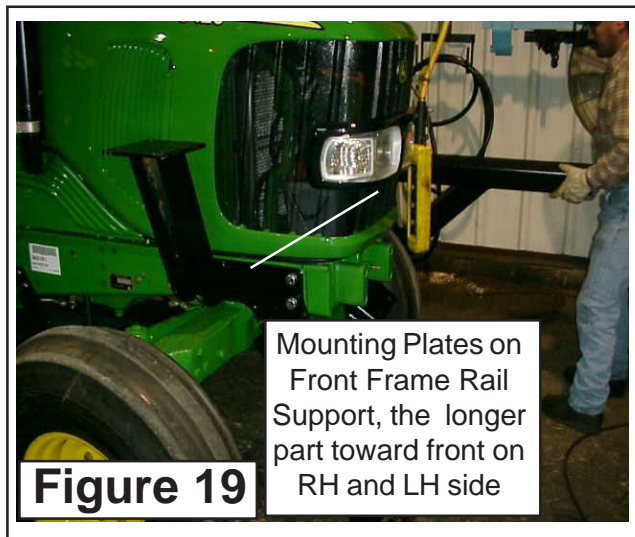
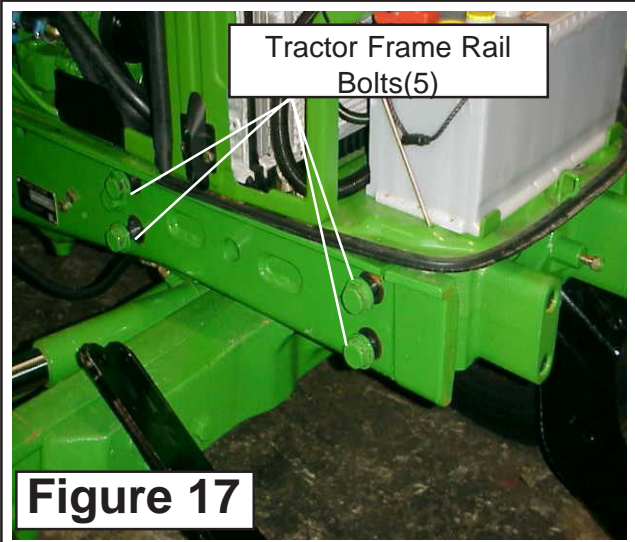
# Pump / Drive Assembly Instructions

## Install Front frame Rail Supports:

1. Remove Bolts from Tractor Frame Rails. Find the front most 4 Bolts in the Tractor Frame Rail, There are 4 on the RH side and 4 on the LH Side. **DO NOT REMOVE THE BOLTS FROM BOTH SIDES AT THE SAME TIME, ONLY** do one side at a time the RH or the LH. For illustration start with the RH Side (**See Figure 17**). The RH & LH Frame Rail Supports have a Right and a Left. They will not interchange and must be mounted on the correct side. Notice the way they are built, the Plate part that bolts to Tractor is longer in the front on both LH & RH. Make sure the longest part is to the front (**See Figure 18**).

2. Install Frame Rail Support RH Side. This works best with a 2 man team. The RH Frame Rail Support is held on with the 5 bolts that are supplied w/ mounting kit. Start all 5 bolts with Lockwasher before any of the 4 are tightened (**See Figure 18**). When tightened down it will look like the picture in Figure 18. Tighten the four retaining bolts for the RH Frame Rail Support before loosening or removing the bolts on the LH side.

3. Install Frame Rail Support LH Side. Make sure that the bolts on the RH side have been tightened before removing the four bolts on the LH side. The LH Frame Rail Support will install the same as the RH side did. Remove the 4 bolts; Install the Front Frame Rail Support. Tighten the 4 bolts through Tractor Frame Rail. (See Figure 19).



# NOTES

# Section 4

## A-Boom

### Frame Rail / High Frame Setup / Pre- Assembly Installation

# Frame Rail Set Up

## Frame Rail Pre-Assembly:

The Frame Rail Set UP. The Frame Rails for the Machete will be set up on the tractor, positioned, measured but not welded. The Machete High frame is set on to Frame Rails, positioned and leveled. After all is set up and positioned it will be Tack Welded in Place on Tractor. Then it will be dis-assembled and welded up on the Shop floor. This is done to ensure better welds and to enable the parts to be turned so the components can be Flat Welded. It has been found that this will make the components stronger. This also gives a chance for all frame components to be test fitted and broken loose during this trial if when another component makes the previous one interferes.

The Tractor should be covered and protected from Spark from the Welder and Grinder at all times. It will be your responsibility to protect the Tractor and its components. DO NOT WELD or GRIND near any Glass or Painted Surface unless it is protected from sparks, these Sparks will damage any surface.

The purpose for Setting Frame up, tack welding it then removing it, is because with the amount of Welding that will have to be done these frame components will need to be repainted. The repainting is easier with frames off. The Frame components are shipped already painted but this is to protect the metal, plan on repainting them after welding.

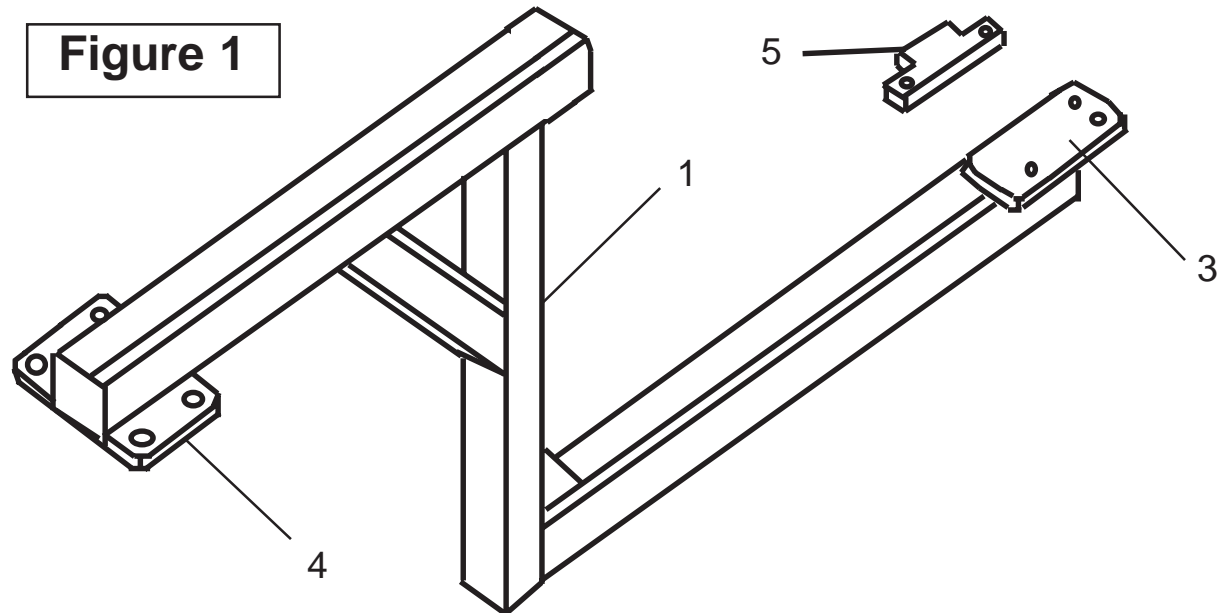
DO NOT weld any frame or component untill instructed to do so in the instructions. Read through this entire instruction book to be familiar with which part goes where and when.

DO NOT try to man handle large components alone, one slip can break a window, damage a hood or worse. Note the order of assembly of other Assemblies, example the Pump Drive Shaft, Front Rail Supports, Rear Stack Valve Modifications and Joystick Assembly are assembled to Tractor before the frame rails. This is because some components will be in the way of others after they are assembled..

# Frame Rail Installation

## Frame Rail Pre-Assembly: (continued)

RH & LH Frame Rails. Shown below are example of Frame rails, There is a Right and Left Frame Rail, They will not interchange from side to side. LH must be mounted on the Left and Right on the Right. To ID which is which, the easiest way is to look for the Counter Weight Mounting Tubes (**See Figure 1 Item 2**), these are welded on to the LH Frame Rail Only. The Rail Mounting Pad (See Figure 1 Item 4) is loose and not welded to the front of the Frame Rail until final assembly.



Item	Part No.	Qty	Description
1	02979767	1	4 WD Frame Rail Weldment, LH (Shown)
	02979768	1	4 WD Frame Rail Weldment, RH (Not Shown)
3	-----	2	Rear Mounting Plate (Welded on LH and RH Frame Rail)
4	02725900	2	Front Rail Mounting Pad (not welded to frame rail when recieved!)
5	02974704	2	Stabilizer Strap, (Axle Straps) Fit above Axle.

### Note:

Item 3 is welded to both LH and RH Frame Rails from the factory. Item 4 will be welded on during assembly procedures. Do not weld on any components until instructed to do so, then check instructions carefully because some components are only to be tack welded then removed to be welded later.

Actual Tube Design may vary from drawing above. Shown above is a general Frame Rail Weldment. While Frame Rails may be designed different the mounting process will be the same.

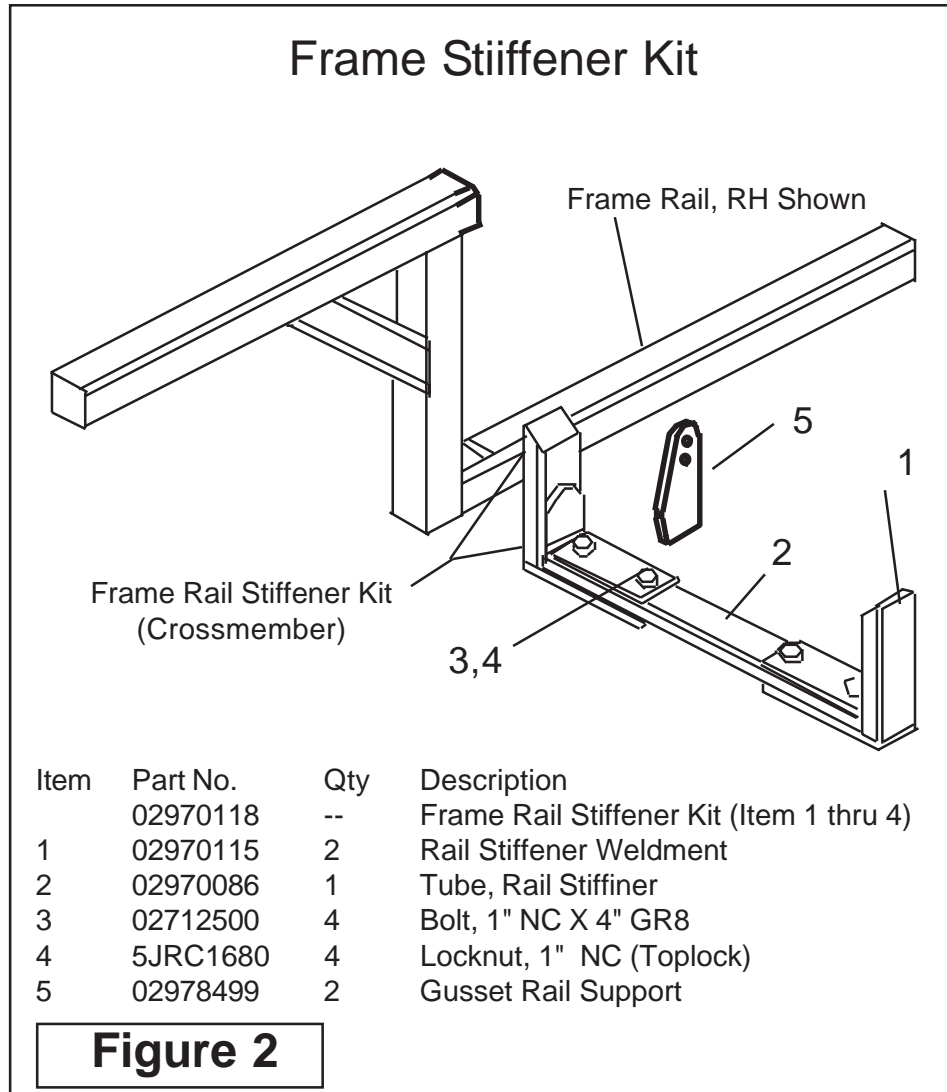
3 Point Arm Stabilizers on tractor will have to be removed when mounting Frame rails and will have to be modified to be used again. This modification will be customers responsibility.



# Frame Rail Installation

## Frame Rail Pre-Assembly: (continued)

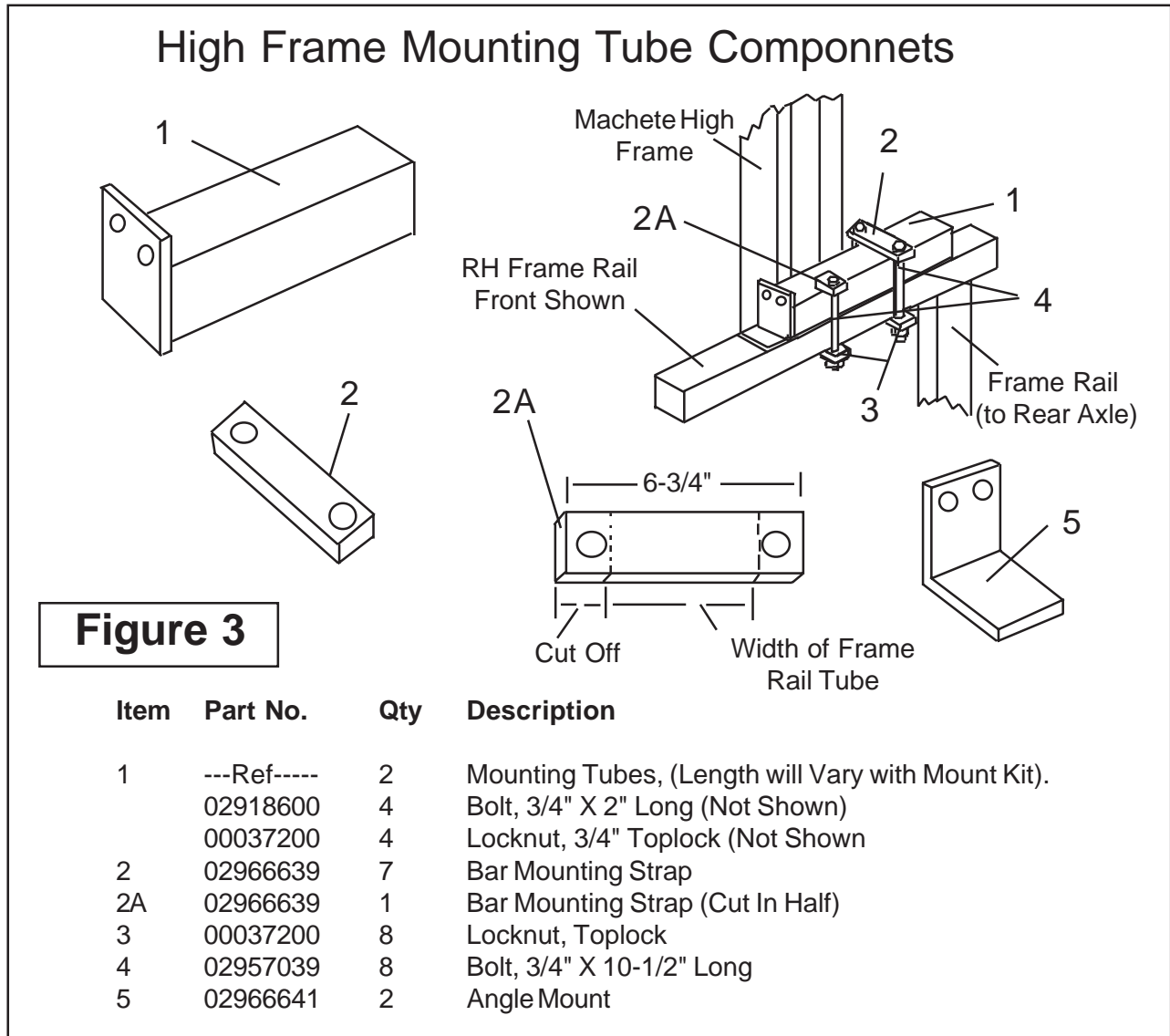
Frame Rail Stiffener Kit (Crossmember). Shown below is the Frame Rail Stiffener Kit. This mounts under the Tractor and will be added to the Frame Rails during Assembly. Item 5 Rail Support Gussets are shipped loose and are not part of the Assembly, they will be bolted to the tractor and when instructed you will need to weld the Frame Rail Support to them **(See Figure 2).**



# Frame Rail Installation

## Frame Rail Pre-Assembly: (continued)

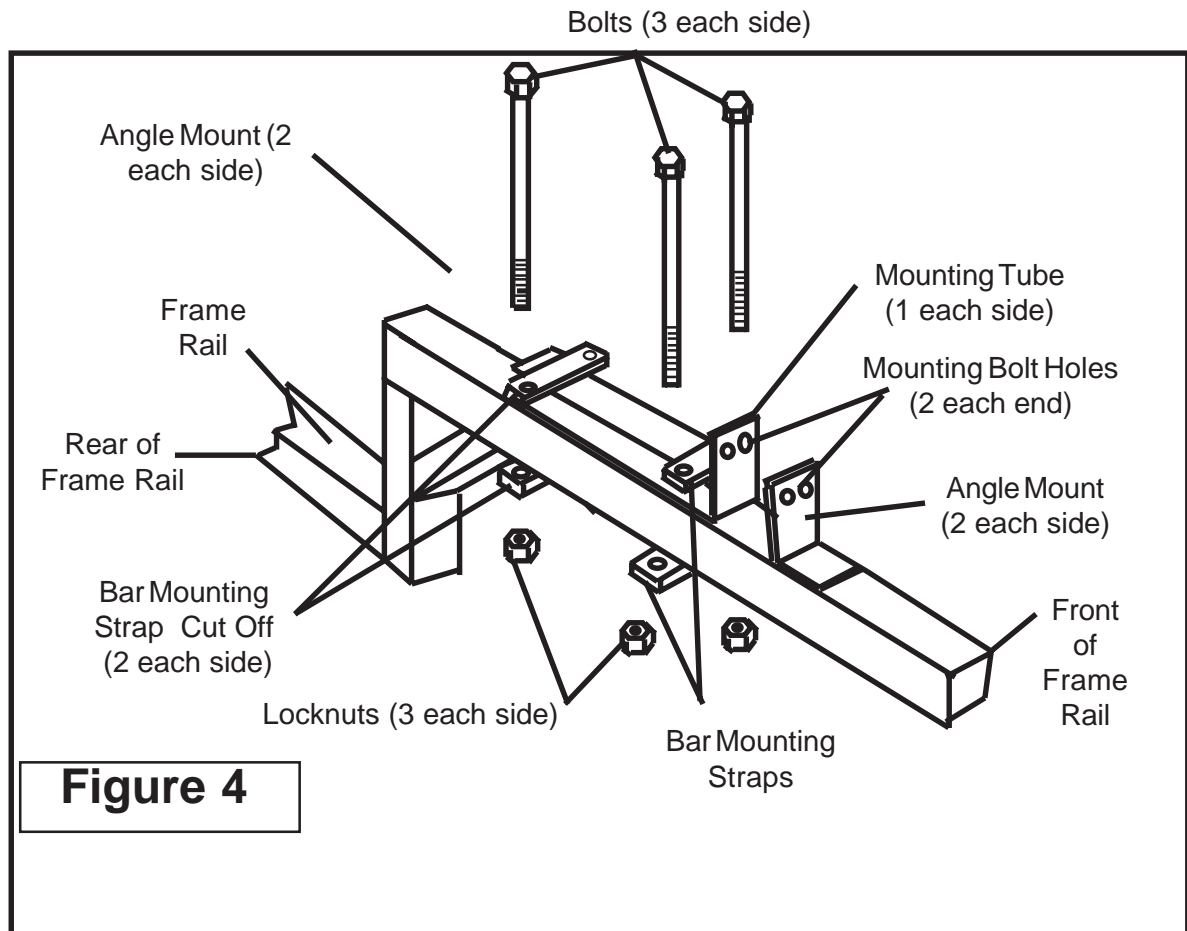
High Frame Mounting Tube Components. (See Figure 3 & 4) These Components are to be laid out and will be tack welded to frame Rails and High frame during Pre-Assembly Process. Locate and ID these Parts for later installation. Remember DO NOT Weld any components until instructed to do so.



# High Frame Installation

## Frame Rail Pre-Assembly: (continued)

High Frame Mounting Tube Components. (See Figure 4) These Components are Sitting in approx. position of assembly to illustrate where they are to be when tack welding them. Space is left between them for illustration only, they will be closer together when assembled. Also See Figure 3 on previous Page.



**Figure 4**

High Frame and King Post Frame Sub-Assembly. (See Figure 5) The High frame will come with the King Post Sub-Assembly built to it. The 2 Wheel drive and 4 Wheel Drive High frames are different and will not interchange between 2 WD and 4 WD Tractors, the 4 Wheel drive High Frame has the King Post Mounting welded higher up on frame than 2 WD Frame. DO NOT try to use a 2 Wheel drive Frame on 4 Wheel Drive Tractor or vice versa, it will not work.

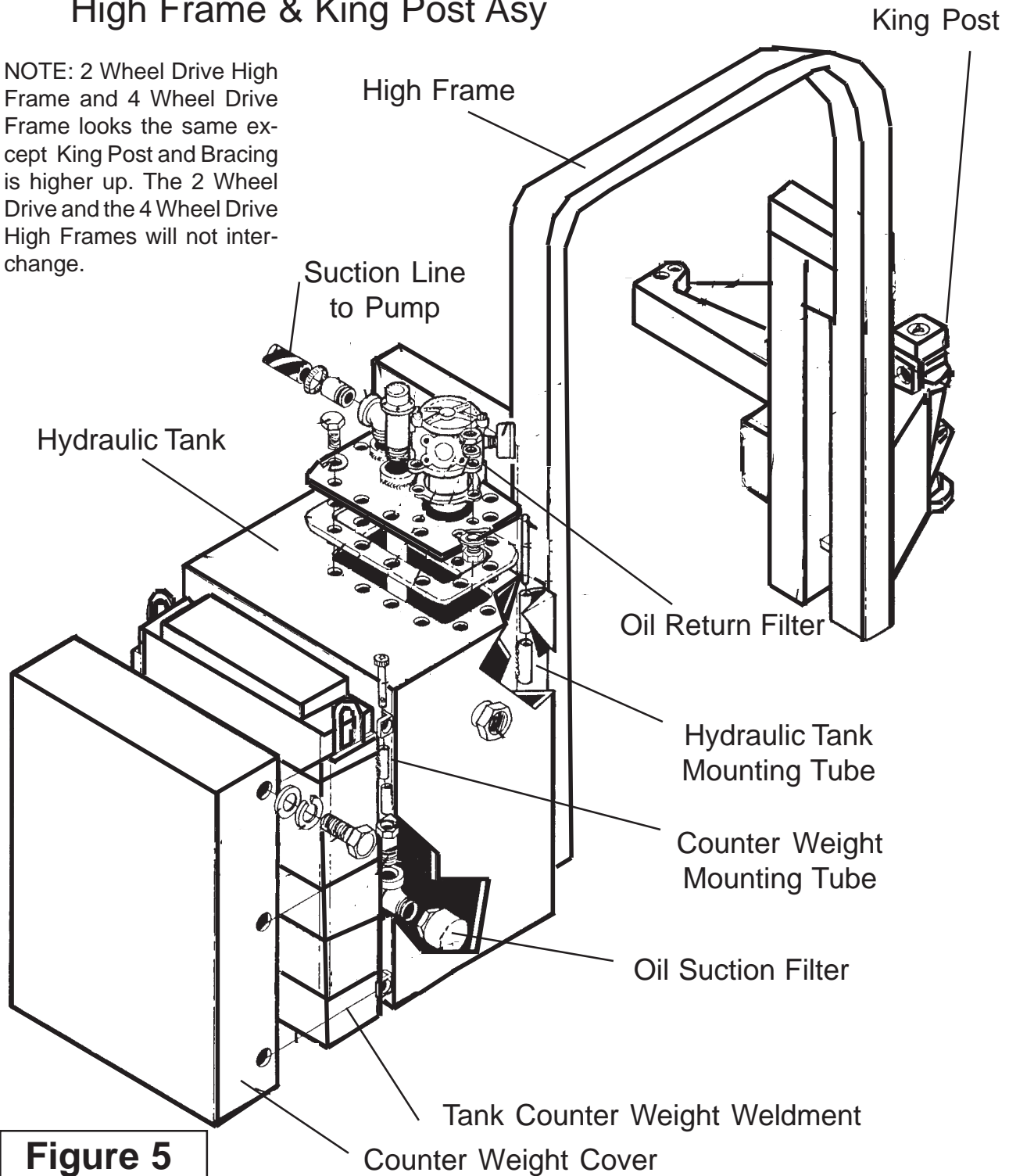
Hydraulic Tank. The Hydraulic Tank is mounted on the LH side of High Frame. It will be mounted by the Mounting tubes that are welded to the High Frame and the Tubes that are welded on to the Hydraulic Tank. There will be long bolts with Allen Heads that will be inserted down through these tubes.

Tank Mounted Counter Weight. There is a tank mounted counter weight that will be mounted on to the Hydraulic Tank using Allen Head Bolts. There will be a cover that bolts on over counter weight.

# High Frame Installation

## High Frame & King Post Asy

NOTE: 2 Wheel Drive High Frame and 4 Wheel Drive Frame looks the same except King Post and Bracing is higher up. The 2 Wheel Drive is higher up. The 2 Wheel Drive and the 4 Wheel Drive High Frames will not interchange.



**Figure 5**

**NOTE:** Shown above is a general view of the High Frame, Counter Weight and Cover and may not look the same as the one for your application. The Assembly procedures will be the same even if the shape of Tank and Weight are different than shown.

# Frame Rail Installation

## Pre-Installing Frame Rails:

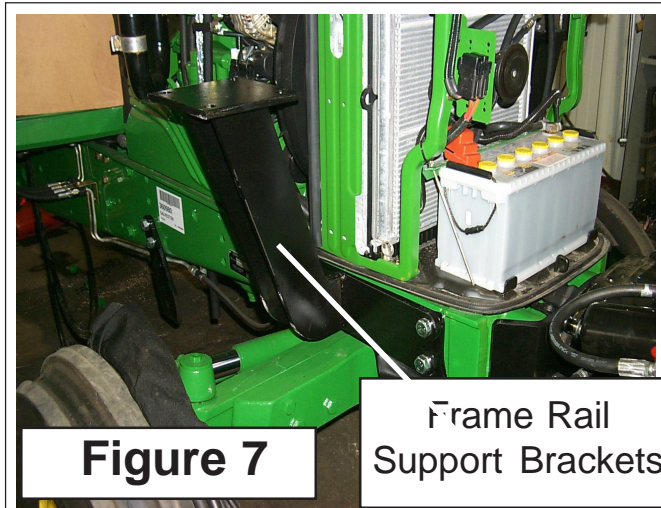
1. Lay Out Components in Display. It is helpful to lay out the component in as neat a display as possible. Lay out the Bolts according to size and length. Lay out the Nuts and washer by size. This will allow you to see how many of each part as you use them and help to identify any missing parts. (See figure 6)

2. Front Frame Rail Supports. These Frame Rail Support Mounts (part # 02979765 LH & 02979766 RH). These should already be mounted from previous Assembly of Front Pump and Drive Shaft Components. It is easier to mount the Pump Drive Shaft before these Frame Supports are installed. If you are mounting the Frame rail supports now, there are important things to remember. There are 4 bolts that go through Tractor Frame that will have to be removed before this can be mounted, DO NOT remove these 4 bolts from both sides (LH & RH) of the Tractor at the same time. Remove the 4 from one side or the other, install the 4 retaining (New Bolts) that hold the Rail Support Weldment on and tighten them. Then go to the other side and remove the 4 Bolts from Tractor Frame Rail and install Machete Frame rail Supports using the 4 new Support Retaining Bolts. The Tank Support brackets connect to the Tractor. These will be mounted when the Frame Rail Supports are installed (See Figure 7).

3. Rail Support Gusset Mount. There are two Bolts in the Tractor frame rail that will need to be removed in order to mount this gusset support. It is easier to do now with the frame rails off. It will need to be installed now, as the Frame Stiffener Assembly will line up with these Gussets. Note the angle on the Gusset as it is being mounted (**See Figure 8**) See Figure 2 for drawing of Frame Stiffener Kit and Part numbers for components.



Figure 6



Frame Rail Support Brackets

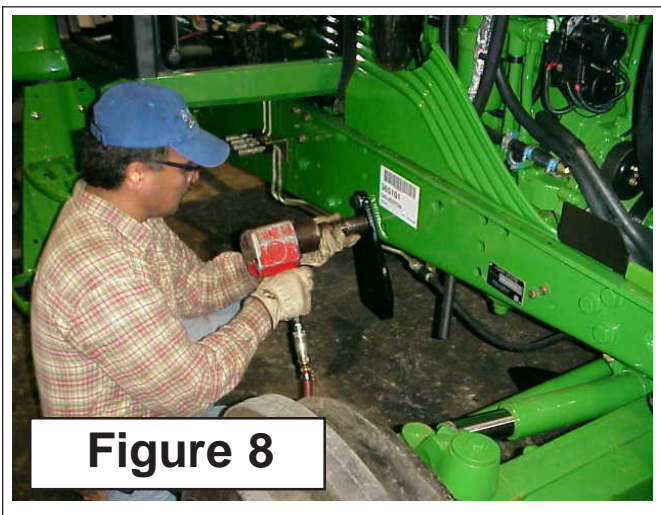


Figure 8

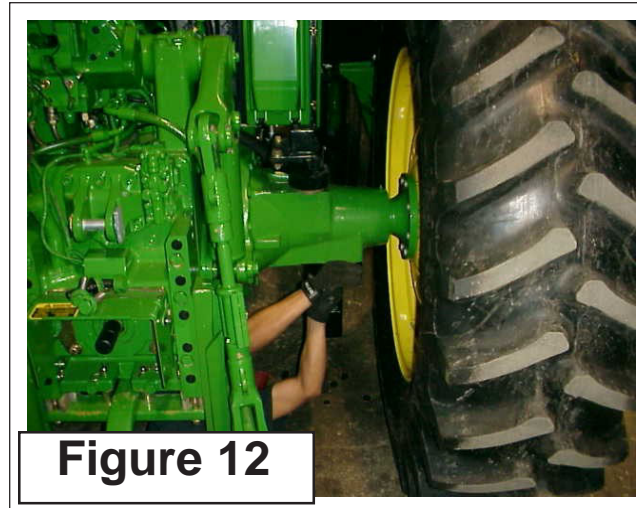
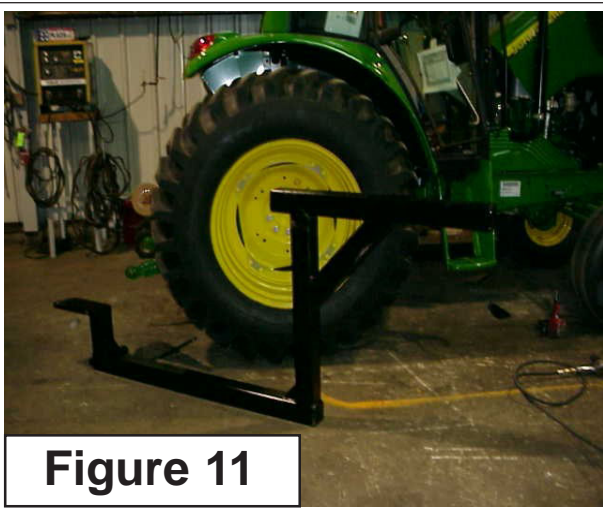
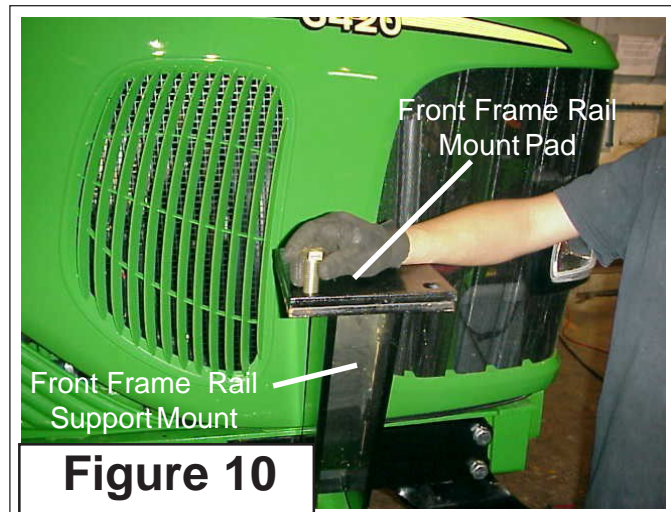
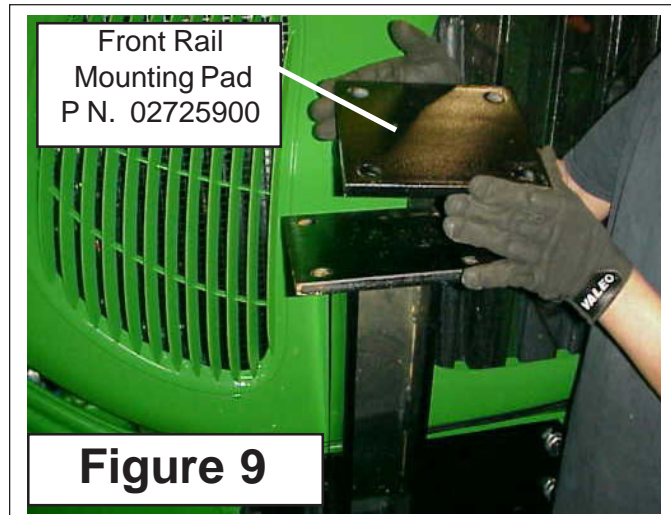
# Frame Rail Installation

## Pre-Installing Frame Rails: (continued)

4. Front Rail Mounting Pad. There are two of these Pads; one is used on the left and one on the right. These Pads are the same so it will not matter which goes on which side. (See Figure 9). Set the Pad down over the Front rail Support aligning the four holes in pad with the four holes Support. Insert the four Bolts into the mount pad and plates on front support mount (See Figure 10). Install a nut on one or two of the Bolts but do not tighten them, the Bolts are only installed to prevent the Pad from moving side to side.

5. Locate RH and LH Frame Rail. There are two different frame rails, RH and LH. Start with either one you want, for illustration we started with the RH (See Figure 11). Remember the LH is the one with the Counter Weight Mount Tubes welded onto it, (See Figure 1)

6. Prepare Tractor Axle Housing. First look up under Tractor at the rear axle where the frame Rails mount you will see holes in the Axle castings on both LH and RH side that has plastic plugs in them. The Plastic Plugs will have to be removed now as they cannot be removed once the Frame Rails are in place (See Figure 12).



# Frame Rail Installation

## Pre-Installing Frame Rails: (continued)

7. Installing Frame Rails. Using a Hoist, lift the frame rail and slide it into place under the right rear Axle. Hold the frame rails as shown to prevent it from moving (**See Figure 13**). Using a Floor Jack (**See Figure 14**) support the Frame Rail up under the Axle. Note: the RH and LH Frame rail will install the same so you can work either side first.

8. Install first Frame Rail to Tractor & Rear Axle. The Frame Rails Mount to the rear Axle of Tractor. The RH Side has Longer Bolts than the LH Side does. This is because the Axle Mounted Boom Rest will also mount here using some of the same Bolts. For now use shorter Bolts to hold Frame Rail up to Axle while you finish the Pre-Installation. The Bolts that were removed from the Tractor when you mounted the Front Frame Rail Supports will work well for this (**See Figure 15**).

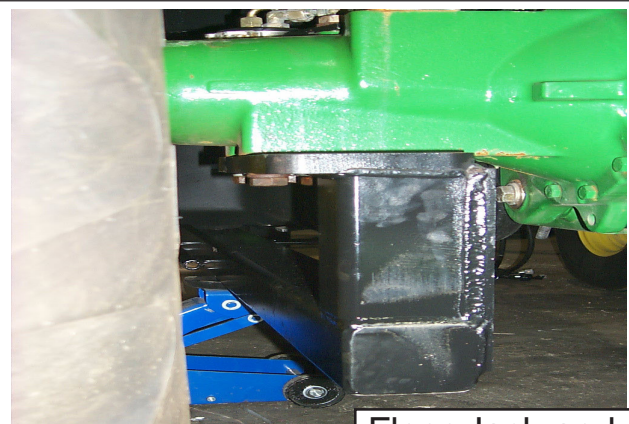
9. Install the other Frame Rail. The other frame rail will install the same as the first did. DO NOT do any welding at this time.

10. Frame Stabilizer Kit. Locate the Frame Stabilizer Kit (**See Figure 16**). This should be bolted together as shown, for fitting under tractor and to Frame rails it must be bolted together.



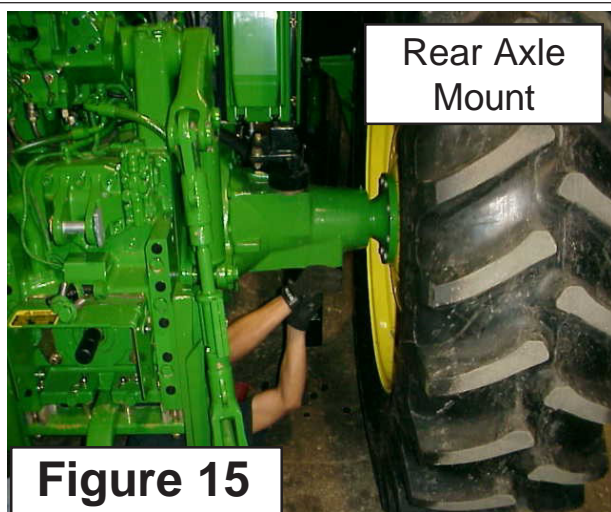
Use Extreme caution so that Frame Rail will not hit Cab or Hood & cause damage

**Figure 13**



**Figure 14**

Floor Jack and Frame Rail



Rear Axle Mount

**Figure 15**



**Figure 16**

# Frame Rail Installation

## Pre-Installing Frame Rails: (continued)

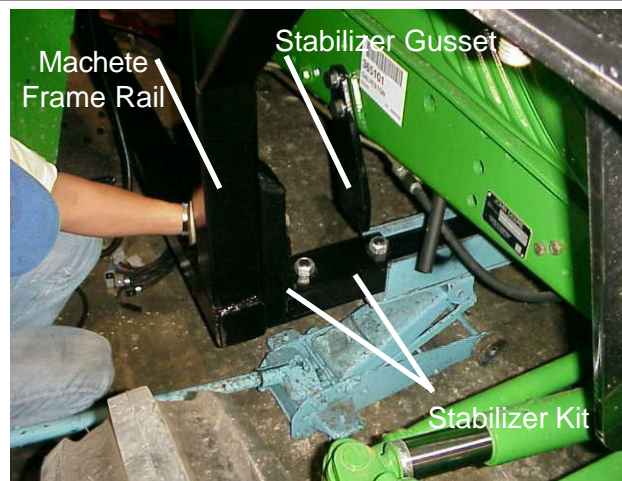
**11. Raising Frame Stabilizer Kit Up Under Tractor.** Using a Floor Jack slide Stabilizer Kit under Tractor right behind the front wheels. (See **Figure 17**). Note the Floor Jack used here has had channel built for it that cradles the square shape, this is also good for supporting the frame rails during assembly. Using Jack helps to align Stabilizer to frame rails. This is shown on a 2 WD Tractor for illustration and is the same for the 4 WD

**12. Align Stabilizer Kit.** Raise Stabilizer Kit with the Floor Jack up until it is flush up against the Stabilizer Gusset Support that should already be bolted to the frame from earlier installation steps (See **Figure 18**). This should be this way on the RH and LH side. DO NOT Weld Gusset to Stabilizer yet this will be done later. Secure the Stabilizer kit to the Frame Rails with C-Clamps on both LH and RH (See **Figure 19**). You may leave the Floor Jack or remove it.

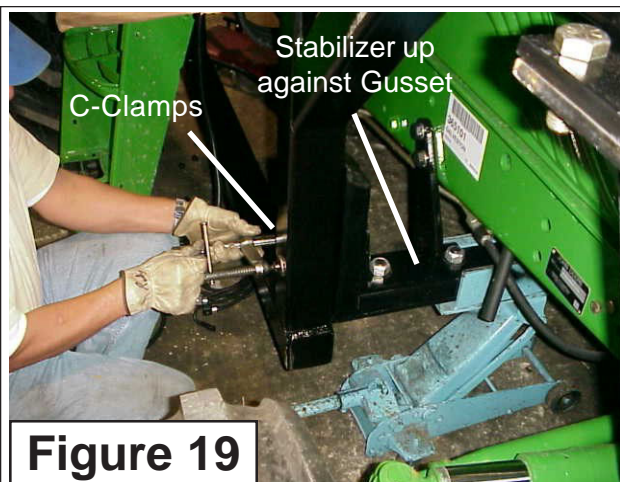
**13. Align Frame Rails on Front Mount Pads.** Locate the Front Frame rails on the mount pad so that there is room for the Bolt heads to clear the Frame Rail. Here we have wedged a Screwdriver with a 1/4" shank between the Bolt Head and the Frame Rail. Anything about that size can be used to keep enough distance so bolt can be removed and reinstalled without interference. Use a C-Clamp to hold it in place when aligned. Do this on Both the RH and LH side. (See **Figure. 20**)



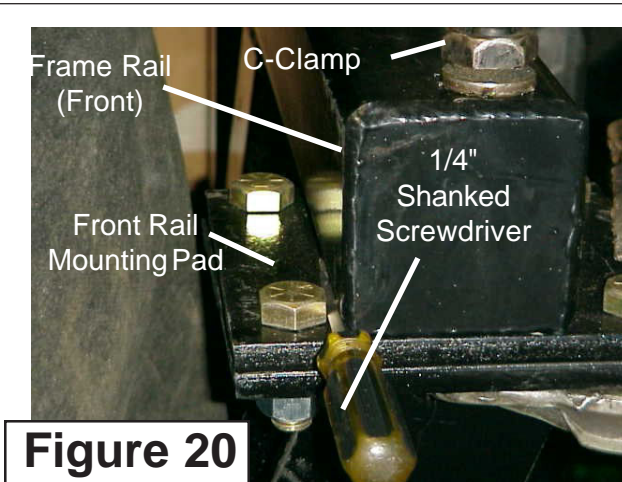
**Figure 17**



**Figure 18**



**Figure 19**



**Figure 20**



# Frame Rail Installation

## Pre-Installing High Frame:

1. High Frame Shipping Pallet. The High frame is shipped bolted to a Pallet, Do not unbolt this from the Pallet until the Hoist has been connected to the High frame. The Hoist must be supporting the weight of the High Frame before any of the bolts holding High frame to pallet are removed.

2. Prepare High Frame for Lifting. There are two lift lugs welded to the top of the High frame for lifting it (See Figure 21). These Lugs will lift the bare High Frame straight without the King Post Sub-Assembly bolted to it. With the King Post Sub-Assembly bolted to the High Frame it will require you to adjust the length of the lifting chain and lifting point to balance the load (See Figure 22) and lift High frame level. High frame must be level when lifted over Frame rails.

3. Level High Frame. Use two magnetic Levels as shown. These magnets should be installed before lifting High frame.

The First Magnetic level is put on the Top of the High Frame on the Bottom Side (See Figure 23). This level will allow you to level the frame from left to right without having to climb up later to use a Level that you hold.

The Second Magnetic Level is put on the Kin Post Pivot toward the front of the tractor so that it will level the High Frame from front to rear as shown (See Figure 24).



Figure 21

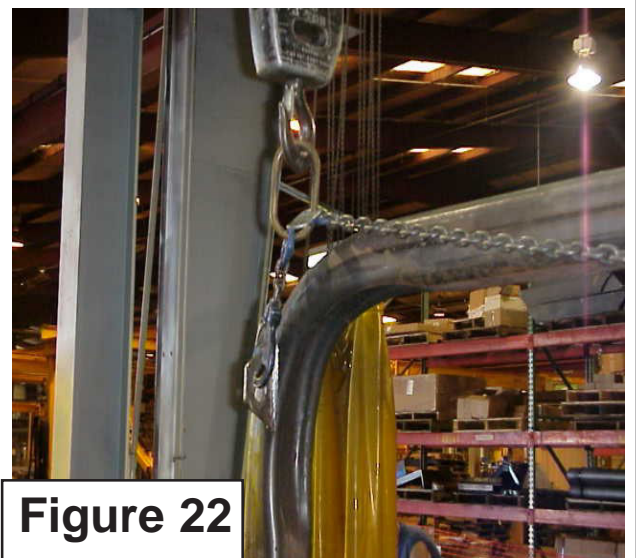


Figure 22

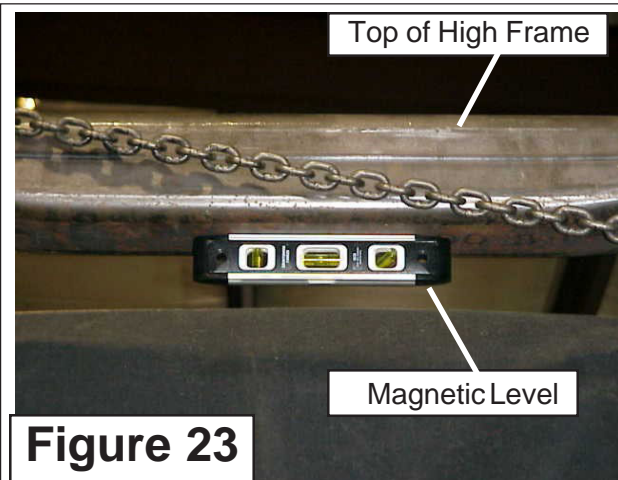


Figure 23

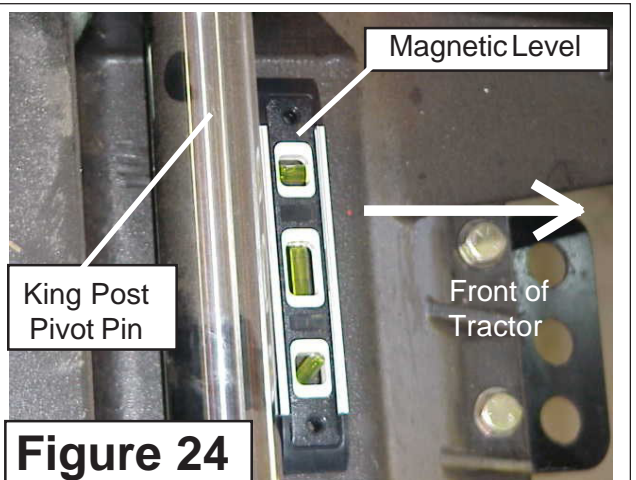


Figure 24

# Frame Rail Installation

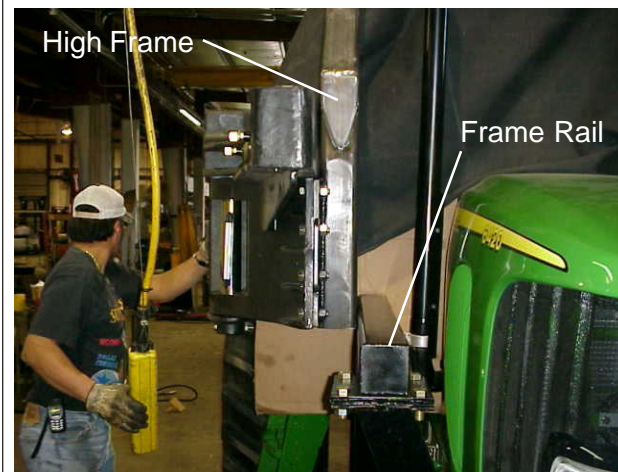
## Pre-Installing High Frame: (continued)

4. Lower High frame down over Tractor. This is a two man job in order to keep control of High Frame on both sides of tractor (See **Figure 25**). Lower the High Frame down over the Frame rails (See **Figure 26**) slowly, as it must straddle the Frame Rails (See **Figure 26**). Lower High Frame until the top of the High Frame is no higher than the cab of The Tractor max. and no lower than 24-1/2" from frame to hood as the min. distance (See **Figure 25**). Another mark to look at is the Horizontal tube of the High frame should be parallel up and down with the Frame Rail Tube as shown on next page (See **Figure 29**).



**Figure 25**

5. Check High Frame for Level. Check the two Magnetic Levels that you installed earlier. The Top Level should be from side to side of the Tractor (See **Figure 27**). The level on the King Post Pivot Pin should be level making High Frame Level straight up and Down (See **Figure 28**). Leave the Magnets on the High frame, as you will have to check then one more time later. DO NOT do any welding at this time.



**Figure 26**

6. Secure High Frame to Frame Rails. Secure the High Frame to the Frame rails with C-Clamps on both sides (See **Figure 29**). Do not weld anything at this time.



**Figure 27**



**Figure 28**

# Frame Rail Installation

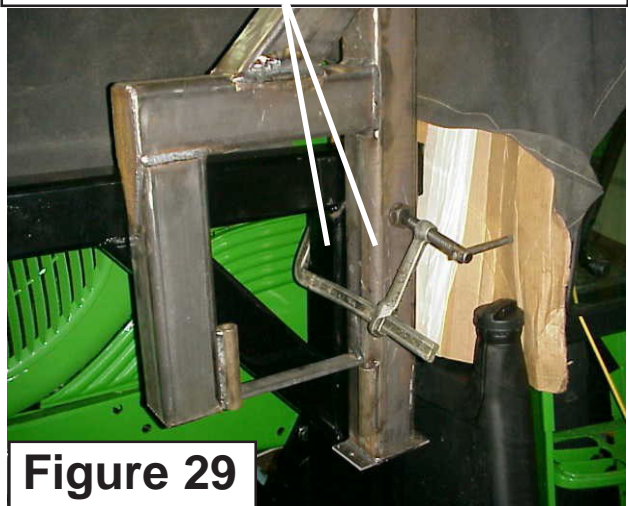
## Pre-Installing High Frame: (continued)

7. Align High frame to Frame Rails. The High Frame Vertical Tube should be as directly above the Vertical tube of the frame rails as possible (**See Figure 30**). The illustrations in figure 30 shows the High Frame not directly over the Frame Rail Vertical Tube, try to get it as directly over it as you can.

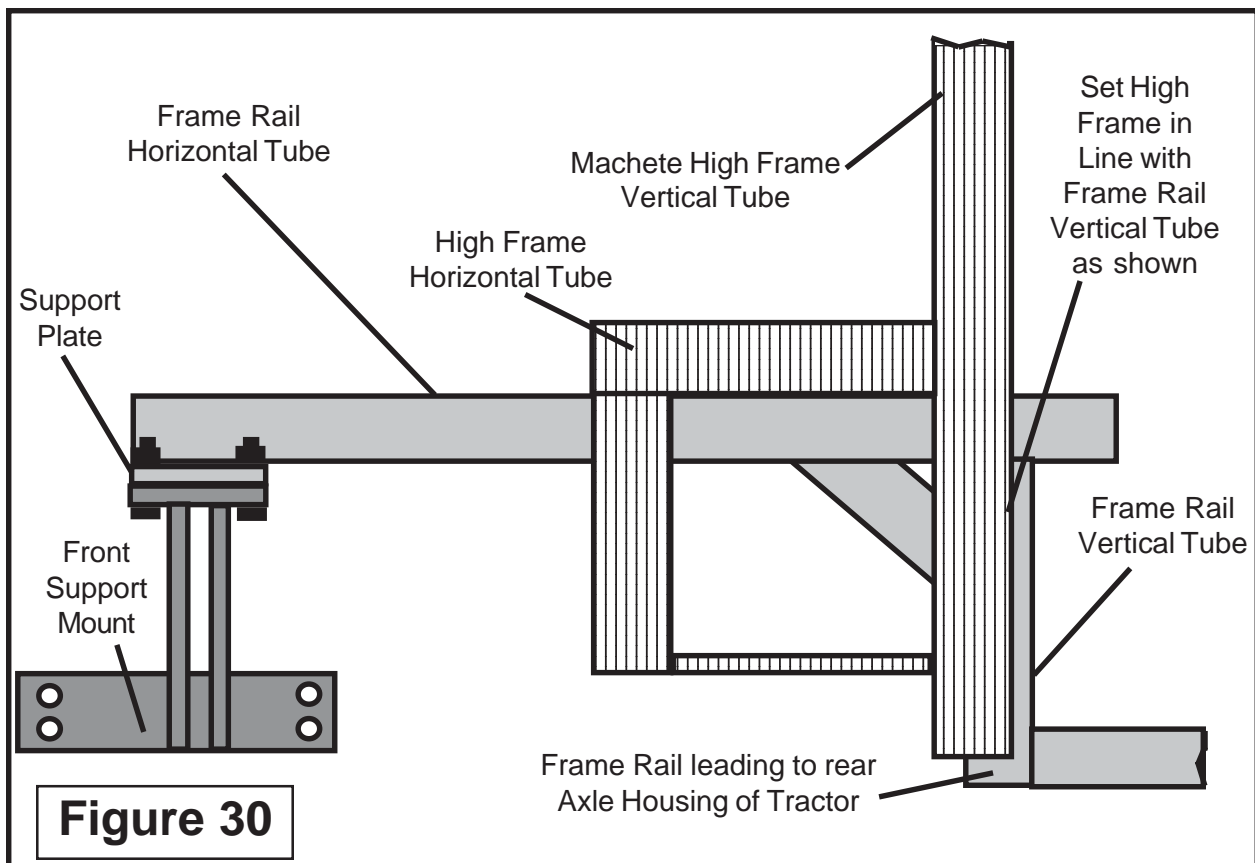
The height of the High frame should be no higher than the Cab of the Tractor. The horizontal tube of the High Frame should be just above the height of the horizontal Tube of the Frame Rail (**See Figure 29 & 30**)

Clamp the High frame to the Frame Rail when aligned and leveled. (**See Figure 29**). Leave the Hoist connected to the High frame for safety and additional support.

Frame Rail Tube & Frame Rail must be align parallel with each other up and down here



**Figure 29**

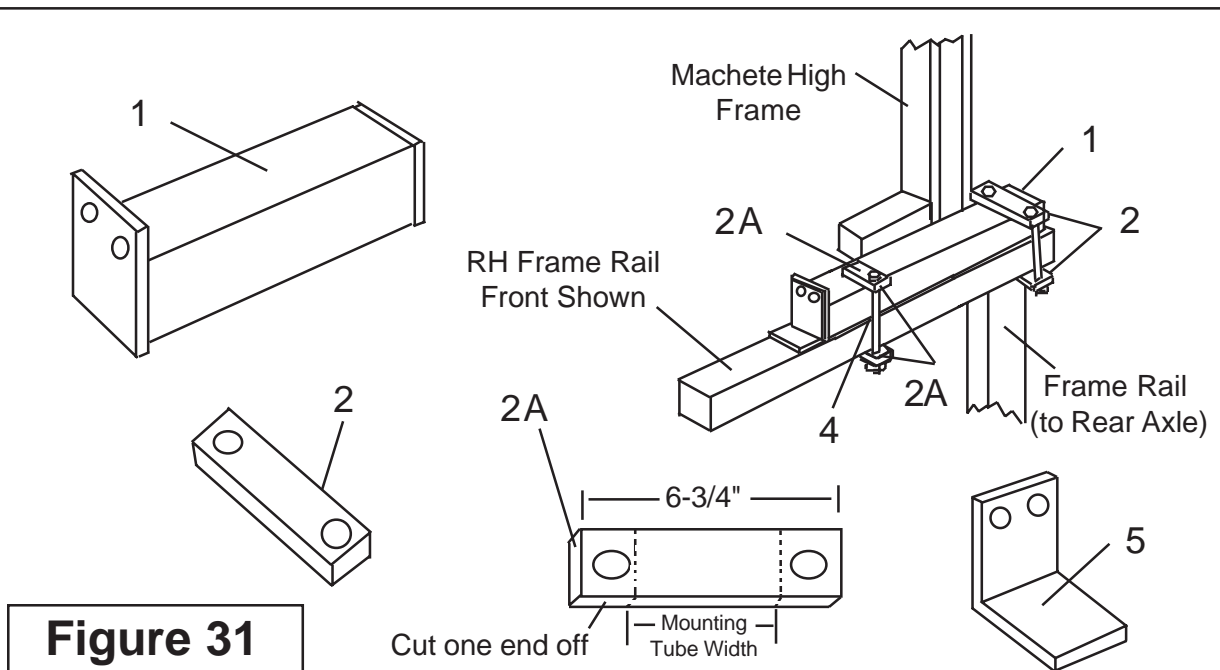


**Figure 30**

8. Re-check all alignment points. Re-check the alignment of the Frame Rails and High Frame for level mounting position. These components must be aligned now before any Tack welding begins.

# Frame Rail Installation

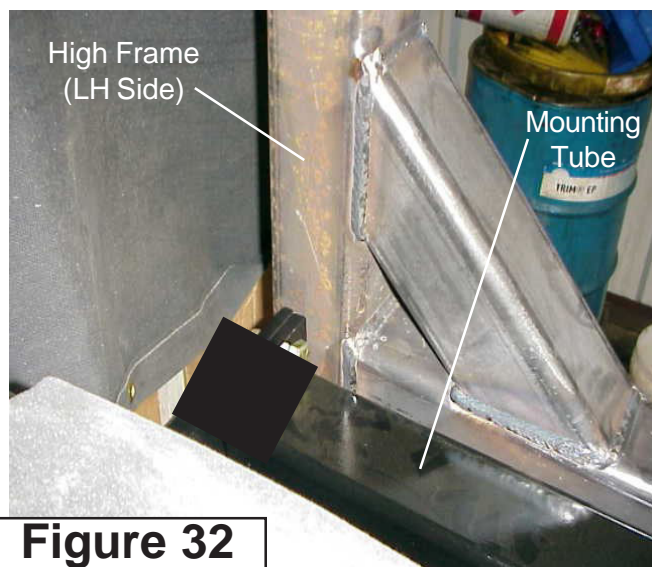
## Pre-Install Mounting Tubes for High Frame: (continued)



**Figure 31**

Item	Part No.	Qty	Description
1	---Ref----	2	Mounting Tubes, (Length may Vary with Mount Kit).
	02918600	4	Bolt, 3/4" X 2" Long (Not Shown)
	00037200	4	Locknut, 3/4" Toplock (Not Shown)
2	02966639	6	Bar Mounting Strap
2A	02966639	2	Bar Mounting Strap (Cut one end off LH Rail only)
3	00037200	8	Locknut, Toplock
4	02957039	8	Bolt, 3/4" X 10-1/2" Long
5	02966641	2	Angle Mount (Front only)

**9. Install Mounting Tubes.** Loosely bolt the Front Angle Mount end of Mounting Tube (**See Figure 32**). Slide 1 Mounting Tube in on top of the Frame Rail on each side, the end that has the Angle Mount bolted to it goes to the Front away from the Tractor Cab. The mounting Tube should be slid back till the end of mounting tube is about 1/2" from the end of the Frame Rail. (**See Figure 34**). Do Not Tack Weld any components at this time. Note: in figure 32 note the location of High Frame Tube Height as compared to Mounting Tube Height, this is the way that it will appear as looking over the Hood of the Tractor toward LH Side.

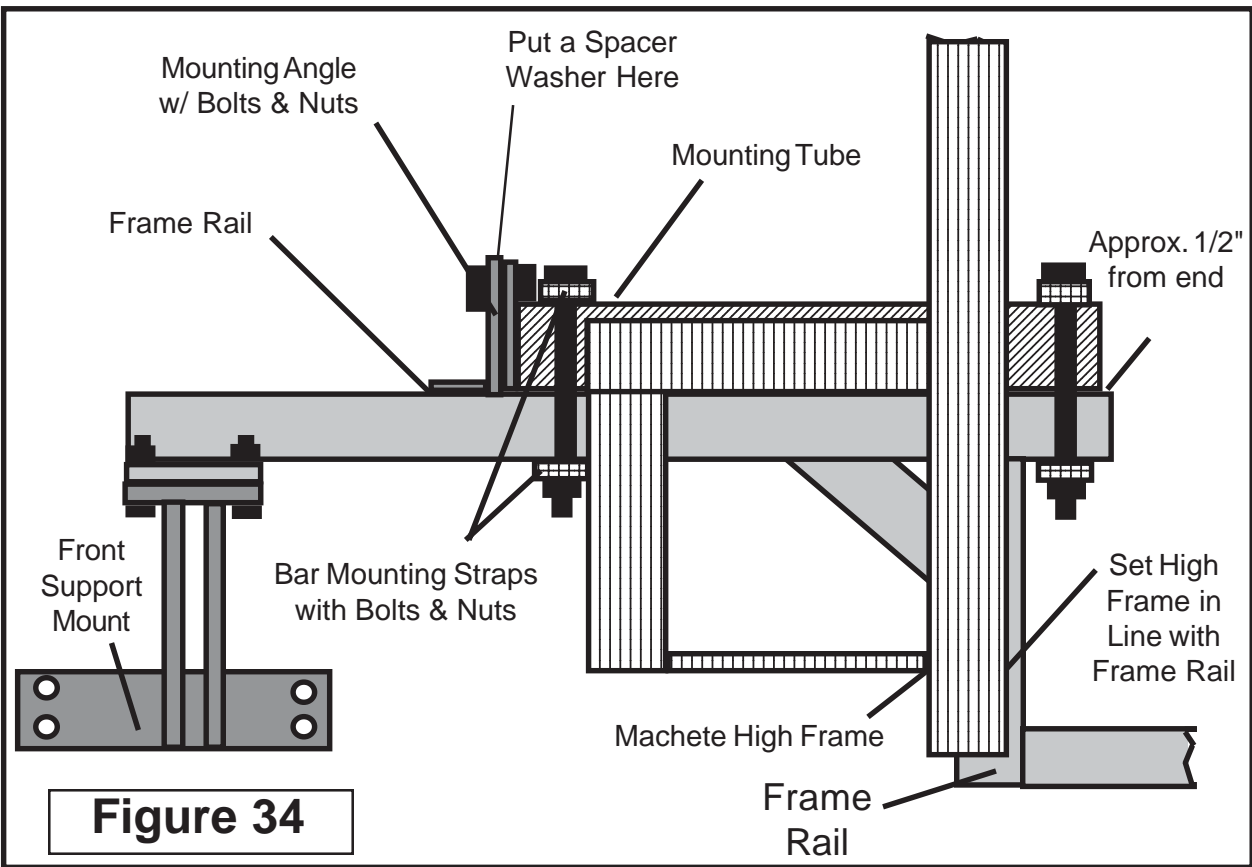
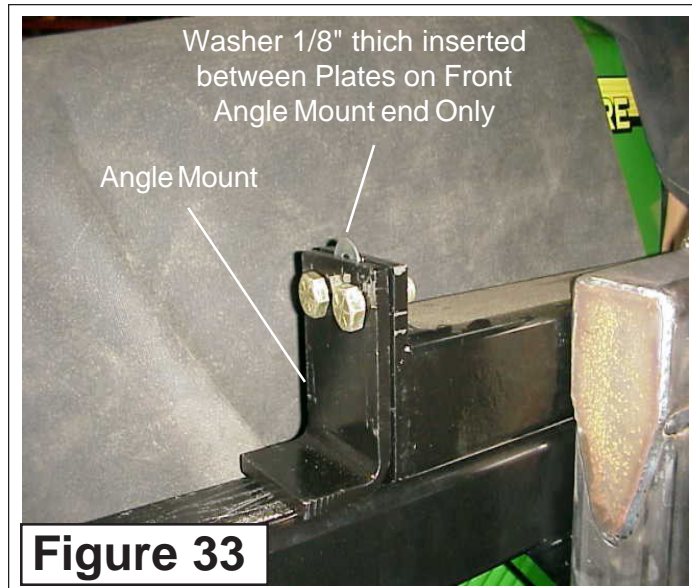


**Figure 32**

# Frame Rail Installation

## Pre-Install Mounting Tubes for High Frame: (continued)

**10. Install Front Angle Mount.** Loosely bolt the Front Angle Mount on the other end (front) of each Mounting Tube (**See Figure 33**). Notice the washer that is installed between the Angle Mount and Mount Tube, This is there because about a 1/16" Gap is needed between the Mount Tube Plate and the Angle Mount Plate. Putting this 1/8" thick washer on the front Angle Mount end only will allow for this Gap on both ends. (**See Figure 33 & 34**) This should be done on right hand and left hand side Mounting Tube. This Gap allows the High Frame with the Mounting Tubes welded onto it, to be lowered down between the front and rear Angle Mount, which will be welded to the Frame rails later. Do not do any tack welding till instructed to.



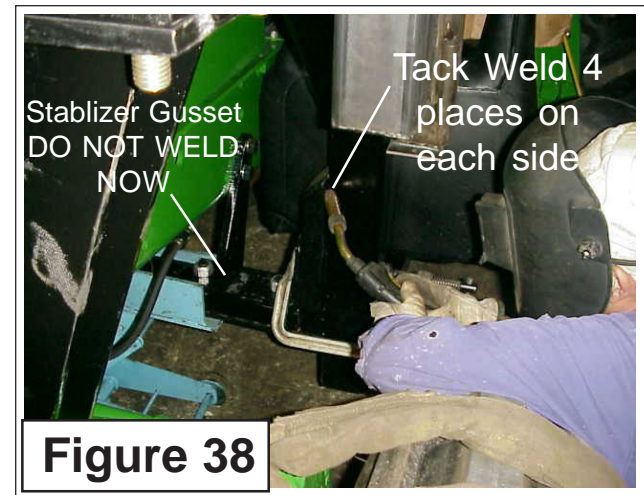
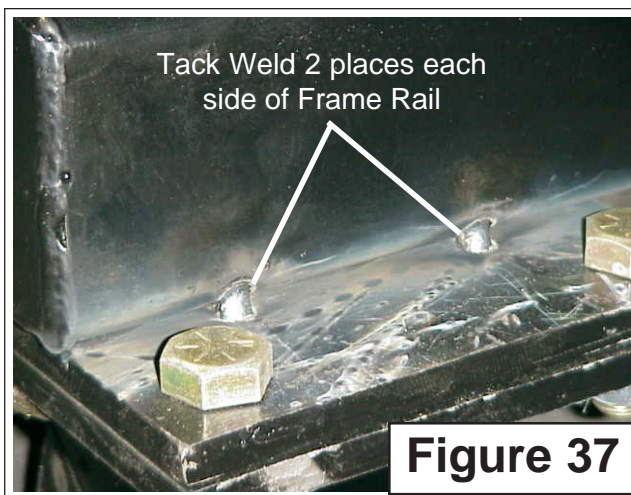
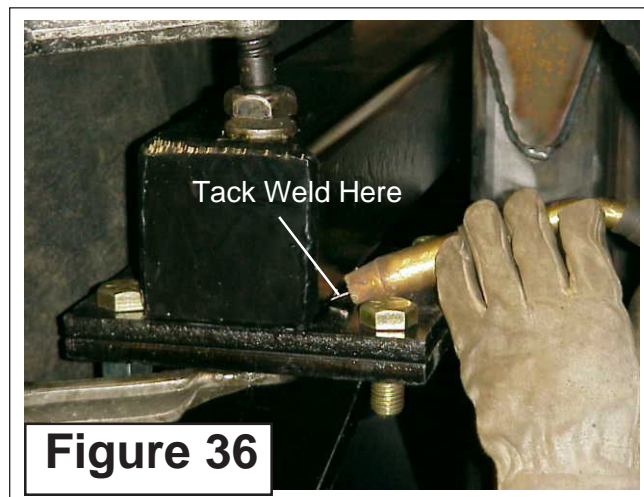
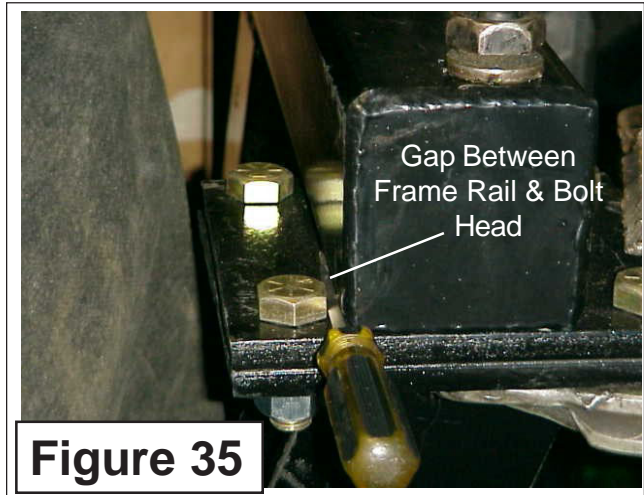
# Frame Rail Installation

## Tack Welding Frame Rails:

1. Tack Weld Frame Rails to Front Mounting Pads. Check to make sure that the Frame rail is still aligned on front rail Mounting Pad, Frame Rail should not interfere with the Mounting Pad bolt heads Check the LH and RH Frame rail (**See Figure 35**). If alignment is correct Tack Weld the Frame Rails to the Front Rail Mounting Pads. (**See Figure 32**). When tack Welding use 4 good tack welds per Frame rail, 2 on each side of Tube. (**See Figure 37**). The C- Clamp on The Frame Rail Tube at the mounting pad can be left on till later.

2. Tack Weld Frame rails to Frame Rail Stiffener. Tack Weld the frame Stiffener Brackets to the Frame Rails, but be sure you DO NOT tack Weld the Stabilizer Gusset at this time (**See Figure 38**). The reason for not welding the stabilizer gusset at this time is because it would make it more difficult for you when you remove the High Frame and Frame rails for final welding. The Tube Crossmember of the Frame Stabilizer can be removed now. Remove the four mounting bolts and slide the Tube forward or back to get it out. (**See Figure 39**).

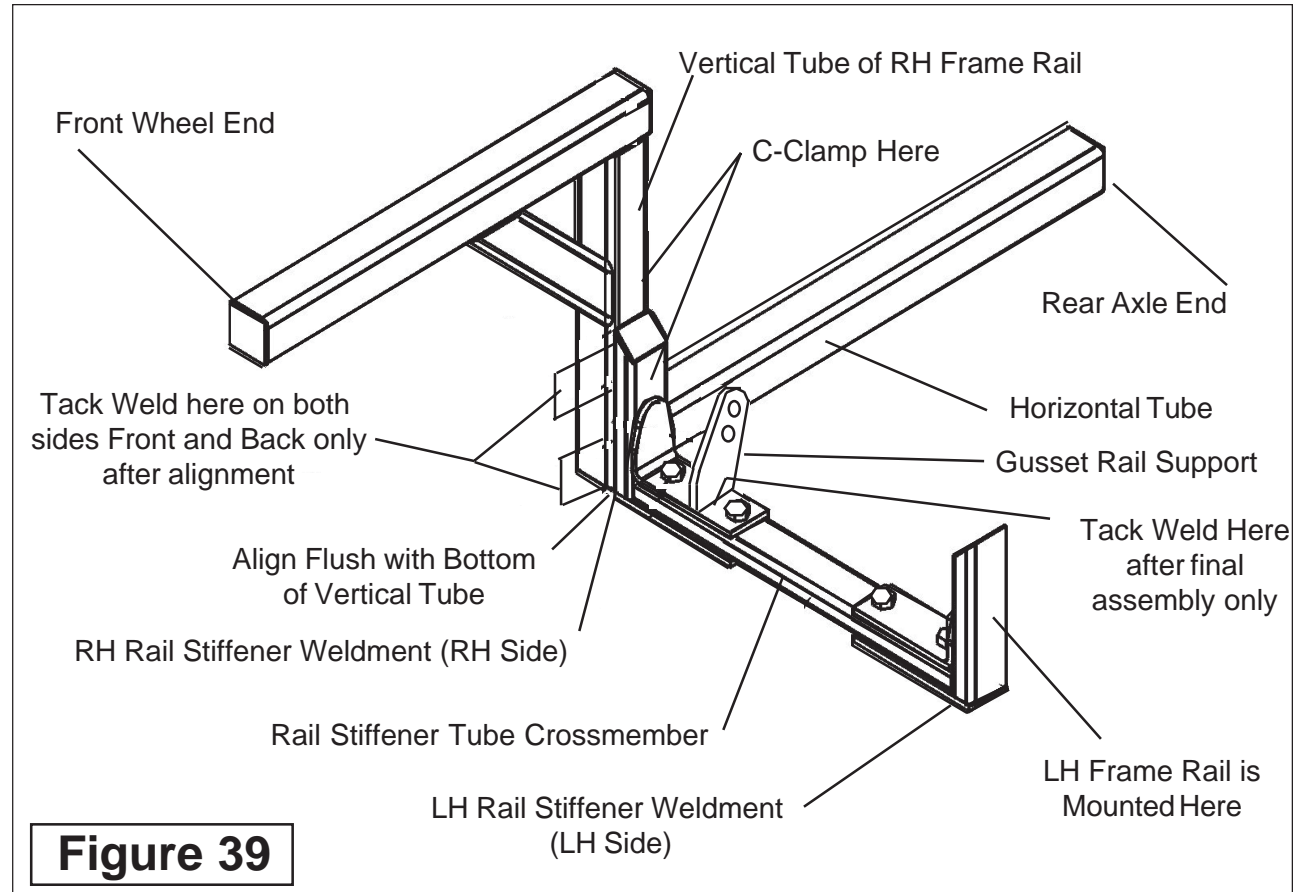
3. Go back and check to make sure you have tack welded the Frame Rail to Mounting Plate and Stabilizer to Frame Rail (**See Figures 31 through 39**).



# Frame Rail Installation

## Tack Welding Frame Rails: (continued)

4. Frame Stiffener Assembly. The frame stiffener is an assembly designed to run under the Tractor to tie the two Frame Rails together and support each other. The Gusset Rail Support is designed to stabilize the Frame Rails to the tractor frame. Re-check the left hand and right hand sides to make sure the alignment is still correct and the tack Welding has been performed.



5. Locate Mounting Tubes and Hardware. See Figure 31 for breakdown of these components.

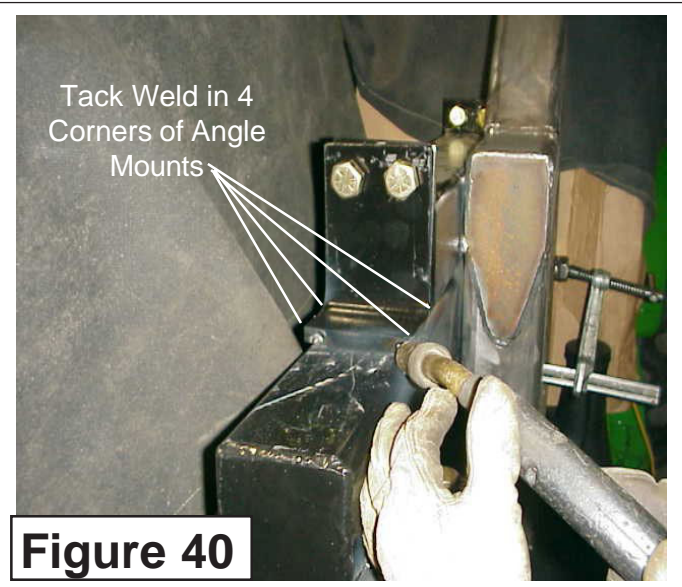
- A. There will be one Mounting Tube for each side; these tubes are the same so it will not matter which is on which side. The Mounting Tubes are the same on either end. (See Figure 31 - Item 1).
- B. There will be 8 Bar Mounting Straps (Part # 02966639); these straps are the same but later in the assembly process 2 will have to be cut (See Figure 31 - Item 2 & 2A).
- C. There are 2 Angle Mounts (Part # 02966641), these have two holes in them and when mounted the hole will be up. (See Figure 31 - Item 5).
- D. There are 8 bolts (Part # 02957039) & Locknuts (Part # 00037200), the bolts are 3/4" X 10-1/2" Long (See Figure 31 - Item 4).

# Frame Rail Installation

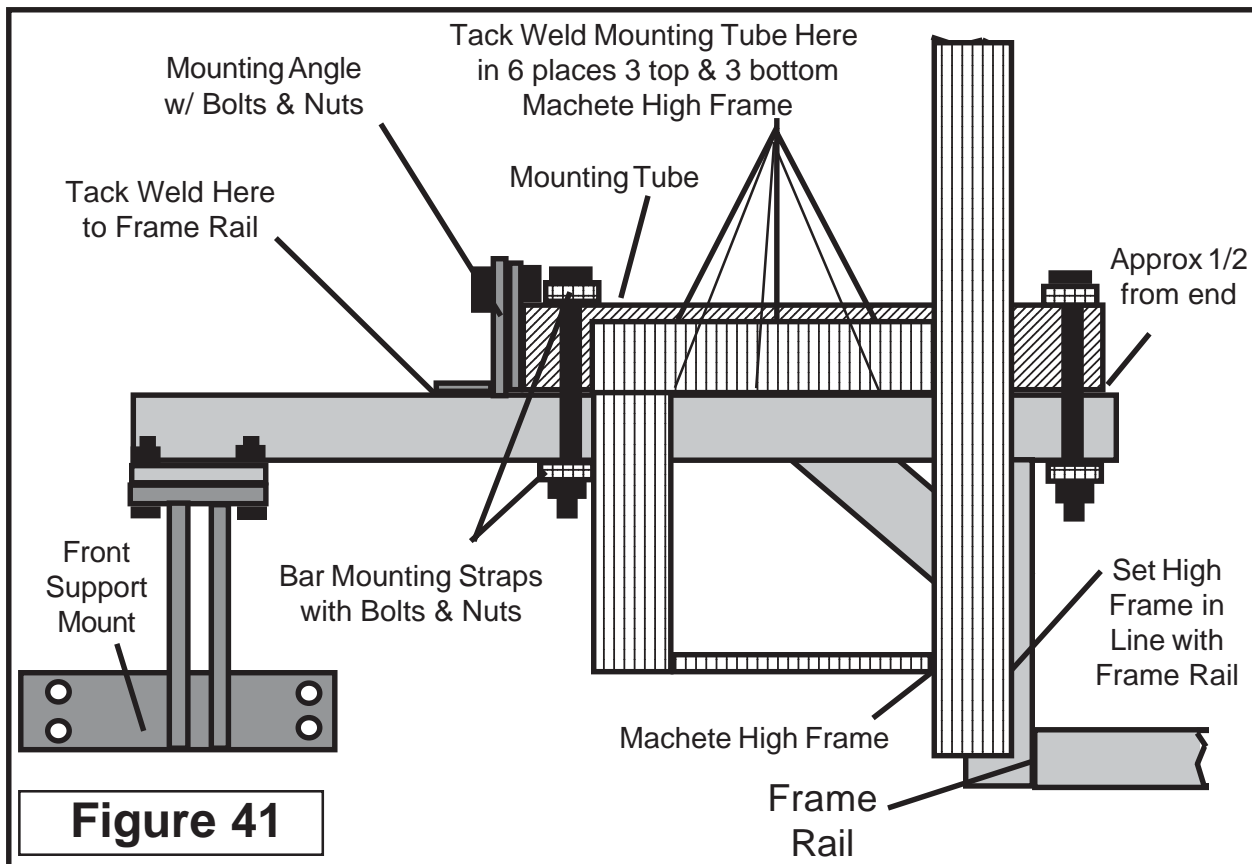
## Tack Welding Frame Rails: (continued)

6. Tack Weld Front and Rear Angle Mounts. The Angle Mounts should be tack Welded to the Frame Rails in 4 places each. This works best by weld a tack Weld in each corner of Angle Mount. (See **Figure 40 & 41**). All 4 of the Angle Mounts must be Tack Welded to frame rail now.

7. Tack Weld Mounting Tubes to High Frame. The Mounting tubes will be Tack Welded to the High Frame in 3 places on top and 3 places on the bottom, on both LH & RH Side (See **Figure 42 & 43**). These Tack Welds need to be done in an alternating pattern so Mounting Tubes do not Lift or move. There should not be any gaps between Frame Rails, High Frame or Mounting Tubes. Do this on LH and RH Frames.



**Figure 40**



**Figure 41**



# Frame Rail Installation

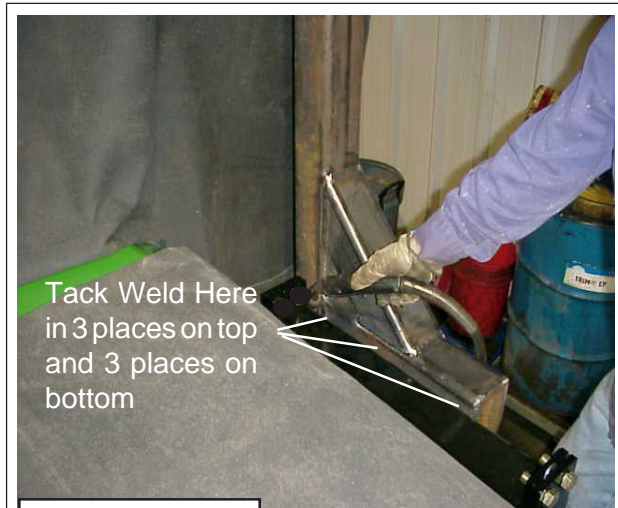
## Tack Welding Frame Rails: (continued)

8. Weld Bar Mounting Straps. The RH Front bar Mounting Straps will have to be cut (**See Figure 31**) and welded to the top of the Mounting Tube (**See Figure 43**). Another one cut off and welded to the Bottom of the Frame Rail. (**See Figure 45**) The length of these Bar mounting straps should be cut so it will not be sticking over past frame rail.

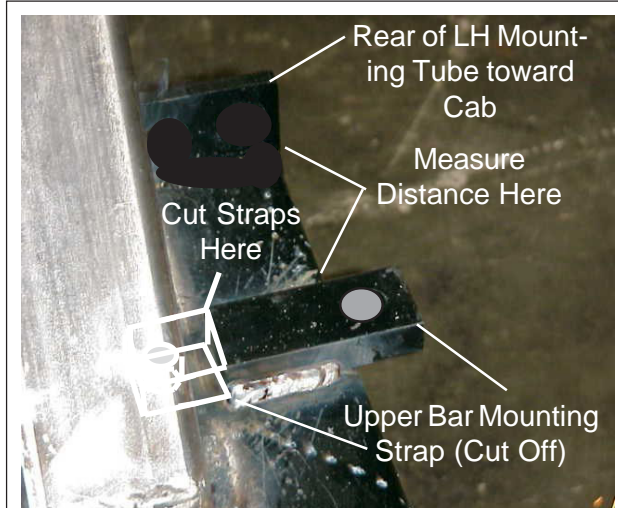
These can be Tack Welded while still mounted on Tractor, Illustrations are shown with frame rails off of Tractor because it is easier to see and it can be done after they are removed from tractor if you want.

These must be Tack welded in alignment when installed, so the holes are in line. If not in line the Bolt cannot be installed. Measure the distance from the Angle Mounting to the Mounting Bar that you have welded to the mounting Tube. (**See Figure 43**). Transfer that measurement to the bottom of the Frame Rail and Tack Weld a cut off Bar Mounting Strap there. (**See Figure 44**). Figure 44 shows a top (Un-Cut) Mounting Bar being held down with a C-Clamp, this is done to make it easier to transfer measurement to lower Bar Mounting Strap. Do not weld a strap to the top of the Frame Rail here. (**See Figure 44**)

9. Recheck that all components are Tack Welded. (**See Figures 31 through 45**)



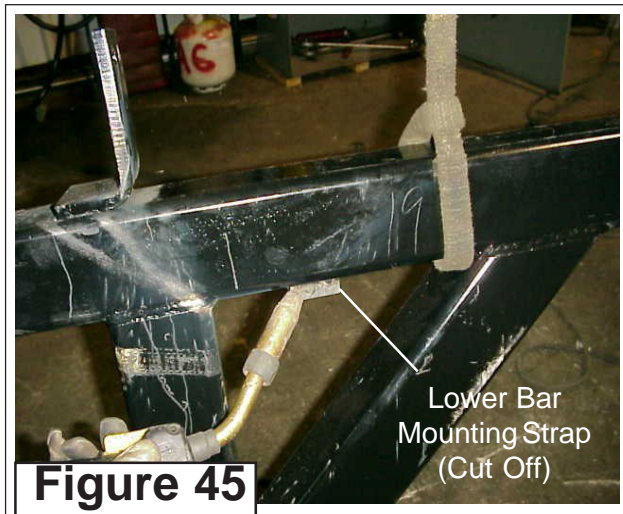
**Figure 42**



**Figure 43**



**Figure 44**



**Figure 45**

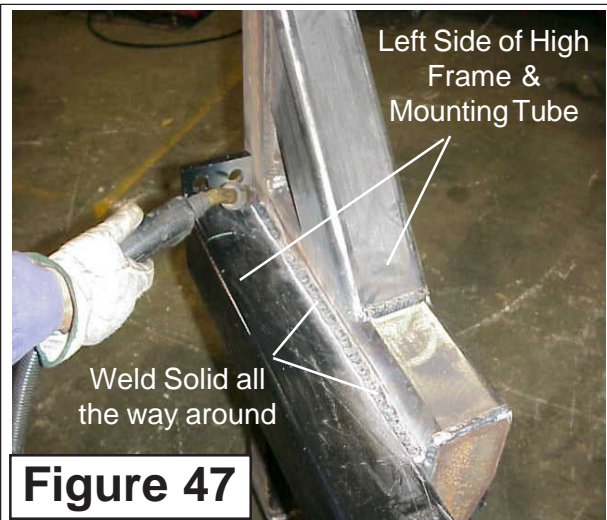
# Frame Rail Installation

## Remove High Frame for Final Welding.:

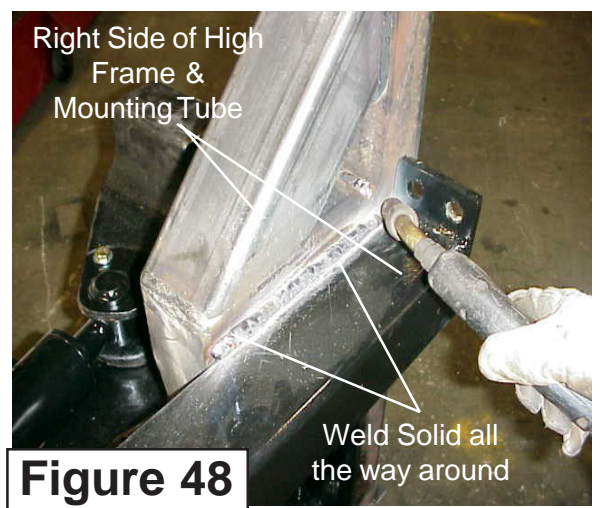
1. Remove and Weld High Frame. Lift the High frame back up off of frame rails (See **Figure 46**). Finish Weld Mount Tubes. The Mounting Tubes are to be welded completely all the way around. This is why it is best to take High frame off, so that the Weld can done as strong as possible and in places that you can't get to with High frame mounted on Frame rails. This is also recommended so Assemblies can be turned while welding to get maximum quality welds.
2. Welding Mounting Tubes all the way around. The Mounting Tubes must be welded to the High Frame all the way around, Turn High frame as required to weld all the way around (See **Figure 49 & 50**). These must be strong Welds.



**Figure 46**



**Figure 47**



**Figure 48**



**Figure 49**



**Figure 50**

# Frame Rail Installation

## Remove High Frame for Welding.:

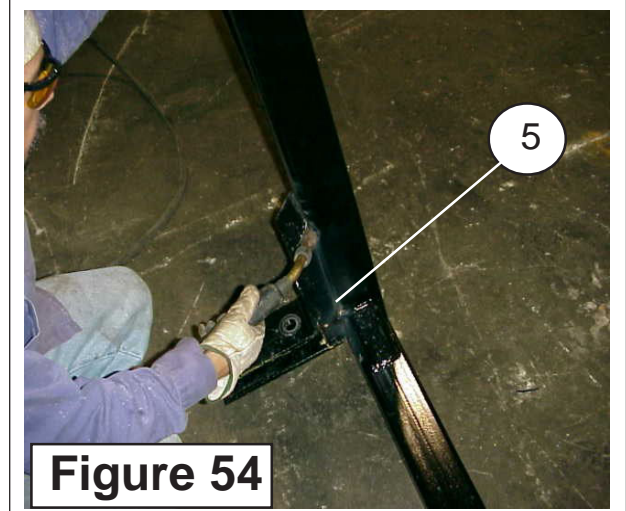
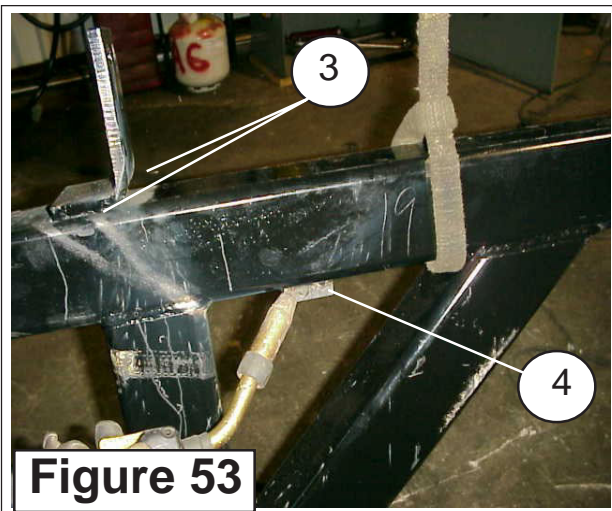
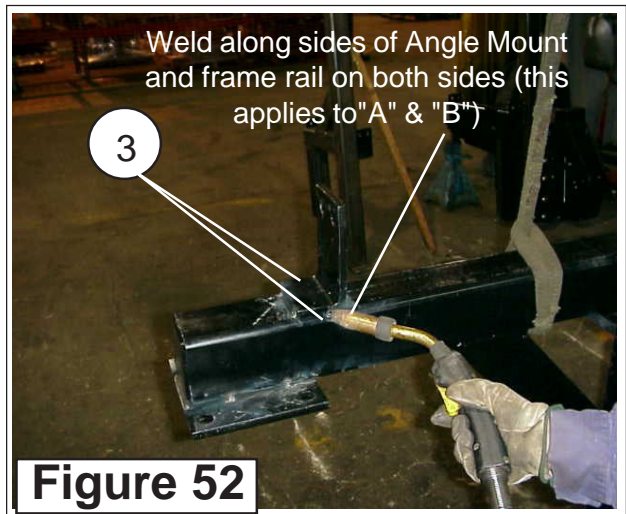
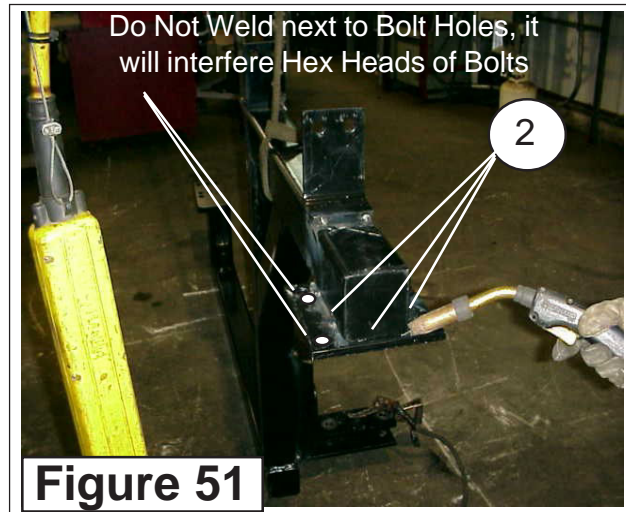
1. Remove Frame Rails. It is best to remove the Frame Rails to weld them. Frame Rails will need to be welded in five places. Note: The RH Frame Rail and the LH Frame Rail will have the same Welding done. For Illustration we are showing the RH Frame Rail, but the LH will have to be done also.

2. Weld Front Mount Plate. Weld down each side between Bolt Holes. Do not Weld to where the Weld will interfere with the Hex Head of Bolts when they are installed. Also weld across the Front of the Mounting Pad. (See Figure 51, 55 & 56)

3. Weld Front Angle Mount. Weld the Front Angle Mount to the Frame Rail on the Sides running parallel to the Frame Rail, Not across Frame Rail (See Figure 52 & 58). Weld the Rear Angle Mount to Frame rail the same as the front (See Figure 53).

4. Bar Mounting Strap. Weld these all the way around, first check your measurements for placement. The Bar Mounting Straps are cut and must be placed to where they will line up with the ones that you welded to the High frame mounting tubes earlier. (See Figure 53)

5. Frame Rail Stiffener Weldment. Weld the Frame stiffener to Frame rail on both sides. (See Figure 24). Touch up or re-paint frame components after welding is completed. There are other components that need to be installed before you reinstall frame.



# Frame Rail Installation

## Remove High Frame for Welding.: (Continued)

6. The Side Rails. These Frame rails will be welded to the Rail Support Plates, so it will be necessary to scrape the paint off approximately 5/8" of the base before attaching. Clamp Side Rails to Front Mount Supports. (See Figure 55). Tack-weld rails to Front Mount Brackets. After thorough check for horizontal and parallel location, weld a solid 1/4" fillet weld bead 8" long on both sides. (See Figure 56). Note that any Step Type Counter Weight must clear the Left Rear Tire.

**NOTE:** There is a Tire Limit, This should be addressed when ordering the Mount Kit designed to fit with the specified Tire Size. If larger than Tires specified for Mount Kit are installed, mounting kit may not fit.

7. The Pig Tail Brackets will be welded to the underside of the Rails, so it will be necessary to scrape the paint off from this area before attaching and welding them (See Figure 57). These Pigtails are to hold the Hoses up. Be sure to run the hoses for the Boom through these Pigtail rings.

**NOTE:** All parts are painted. When welding is required, scrape away the paint in the area to be welded to help assure the integrity of the weld. Repaint / Touch-up welded parts after finished welding.

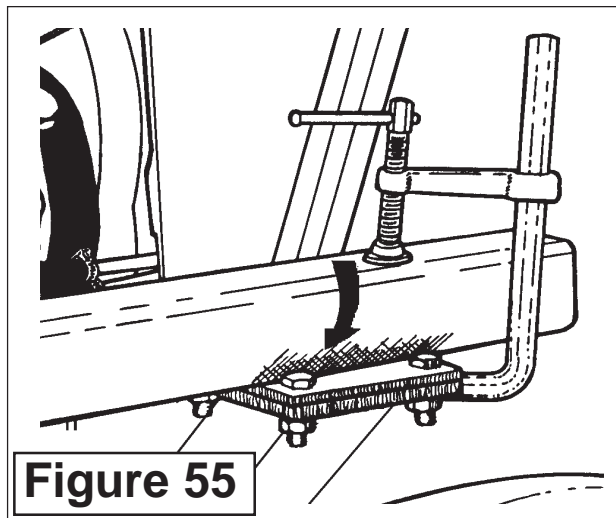


Figure 55

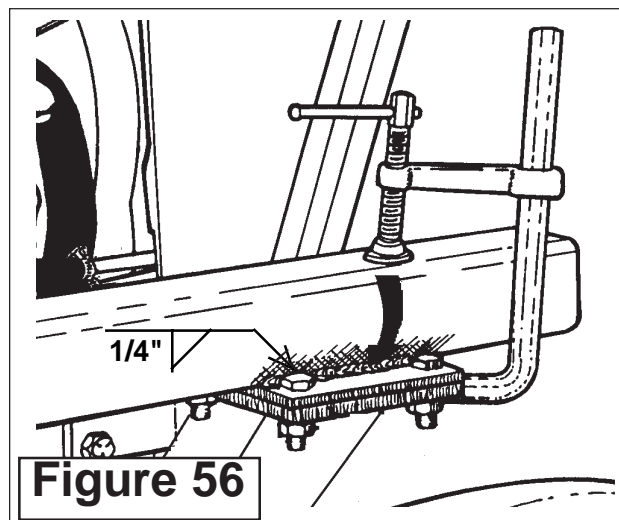


Figure 56

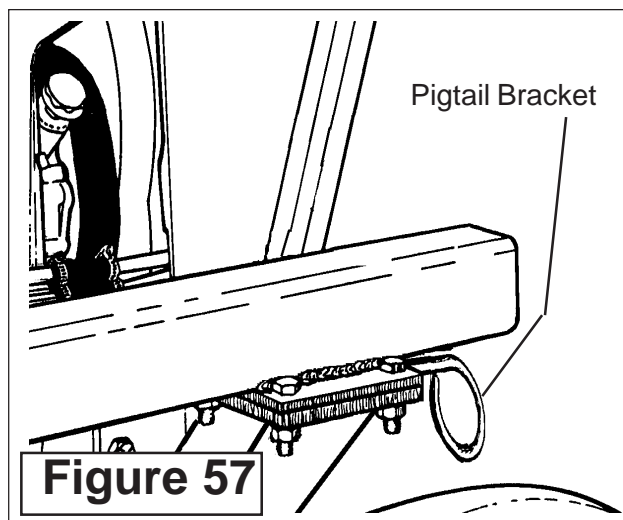


Figure 57

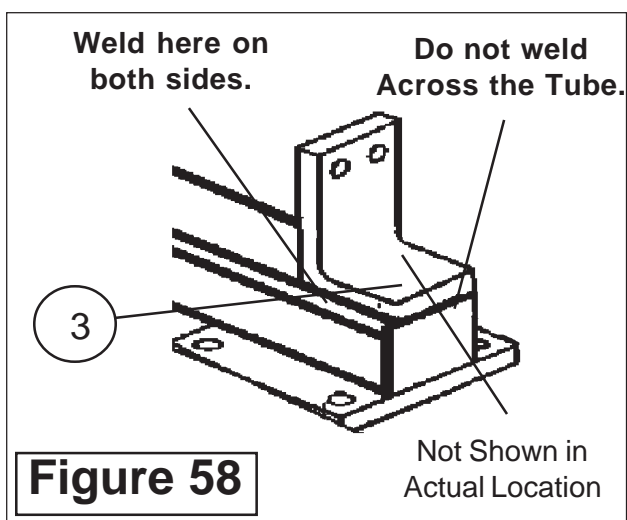


Figure 58

# NOTES

# Section 5

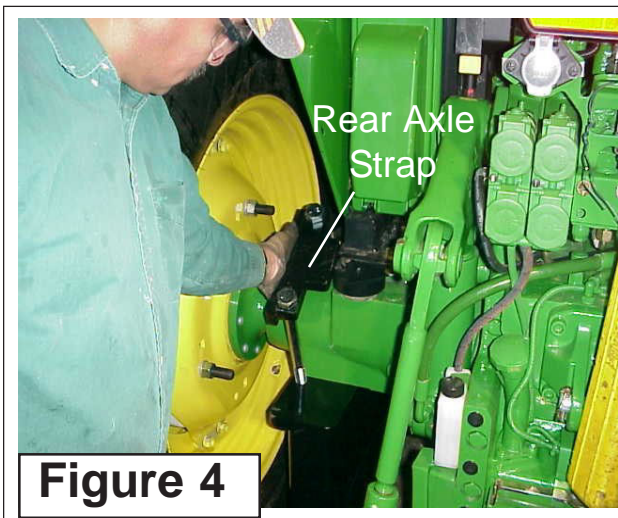
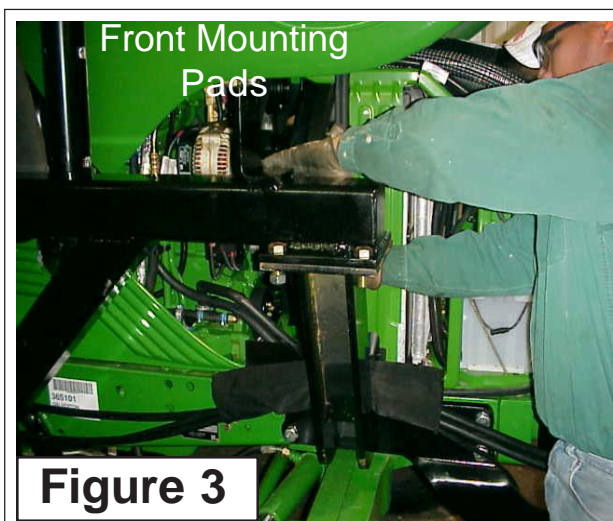
## A-Boom

### Frame Rail & High Frame Final Installation

# Frame Rail Installation

## Re-Install Frame Rails to Tractor:

1. Re-Install Frame Rails. With the Welding done touch up or re-paint frame rails before re-installing them. The RH and the LH Rail will install to the Tractor the same except for the Boom rest that installs on the RH Rail Rear Mount. It is best to do the Left Hand Frame Rail first then the RH Rail. Use a Hoist to install Frame rails to Tractor. (See Figure 1).
2. Install the Bolts into the rear Axle Housing to support the rear of the frame rails. This is the same for LH & RH. Snug the Bolts only. Do not tighten them yet because the frame rails will have to be moved around to align all the Bolt Holes. (See Figure 56). The RH rear Frame Rail Mounting will need the Bolts removed to install the Axle Mounted Boom Rest (See figure 5, 6 & 7).
3. Install the Bolts into the front mounting Plates on the LH and RH Side. Snug them only. (See Figure 3).
4. Install the LH Axle Straps. The LH Axle Strap can be installed now (See Figure 4). The Left Hand Axle Strap uses two long Bolts with Nuts. The Bolts go down through the Holes in the rear Axle Mounting Plate that is welded to the rear of the frame rail. Once the Rear Axle Strap is installed the Bolts for the LH Frame Rail and Axle Strap, snug the Bolts only, do not tightened them down (See Figure 1, 2, 3 & 4).

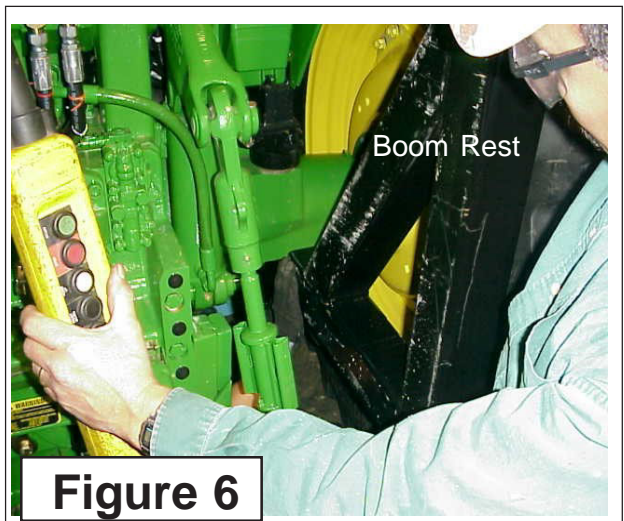
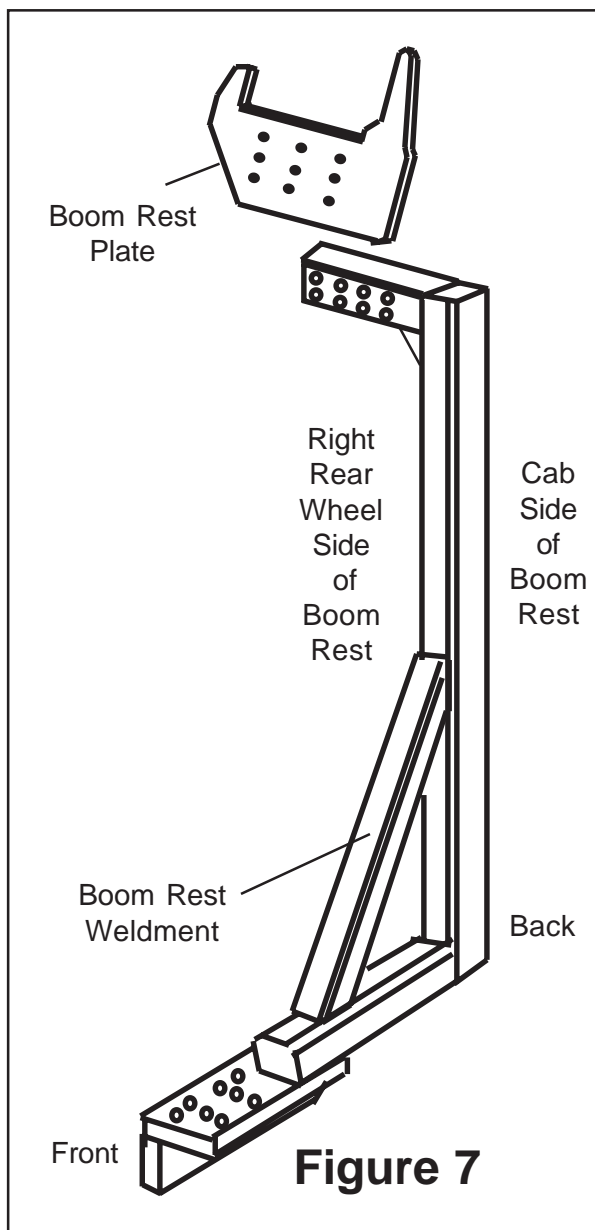


# Frame Rail Installation

## Re-Install Frame Rails to Tractor: (continued)

5. Install Axle Mounted Boom Rest. This will require two people, one to align the Boom rest with the Hoist and one to align the Bolt holes on the bottom to start them into the Axle Housing. (See **Figure 5, 6 & 7**)

When the Bolts are installed into the Frame Rail & Boom Rest Plates and snugged up to Axle housing, install the RH Axle Mounting Strap (See **Figure 8, 9 & 10**). Do not tighten Bolts snug them only for now.



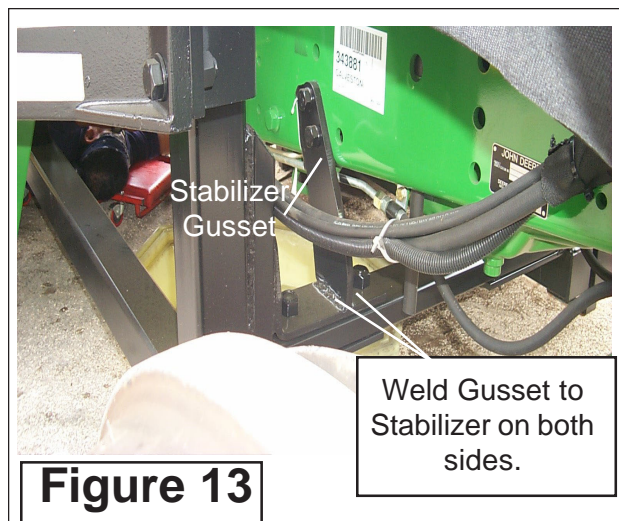
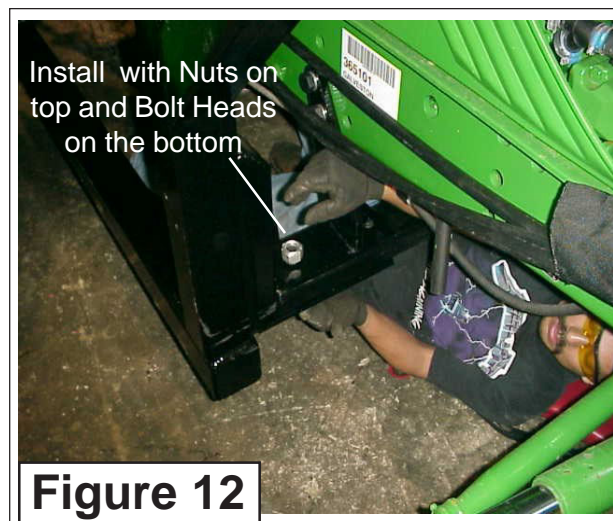
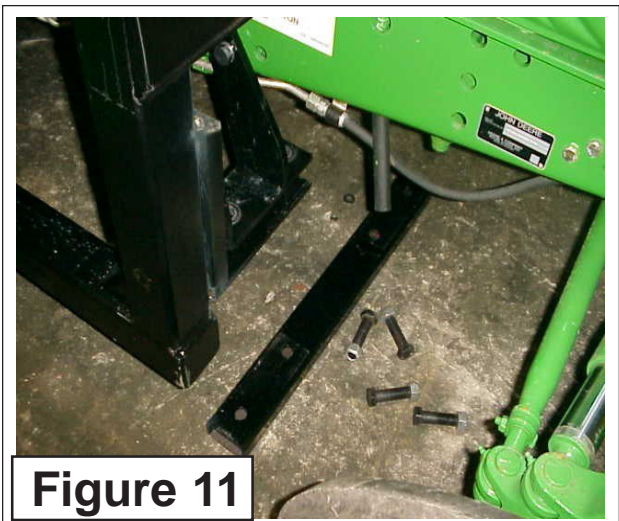
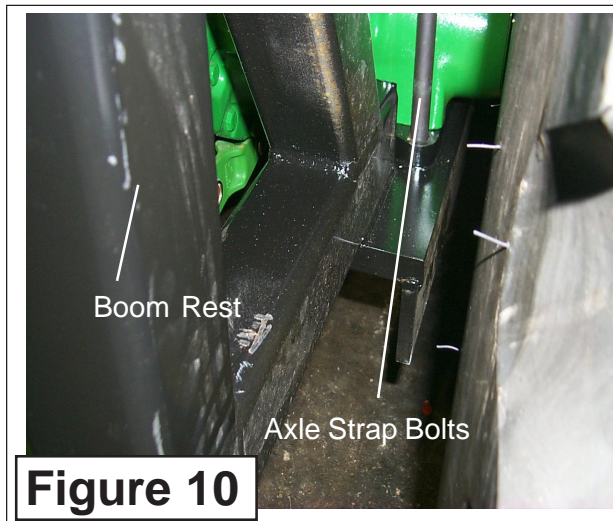
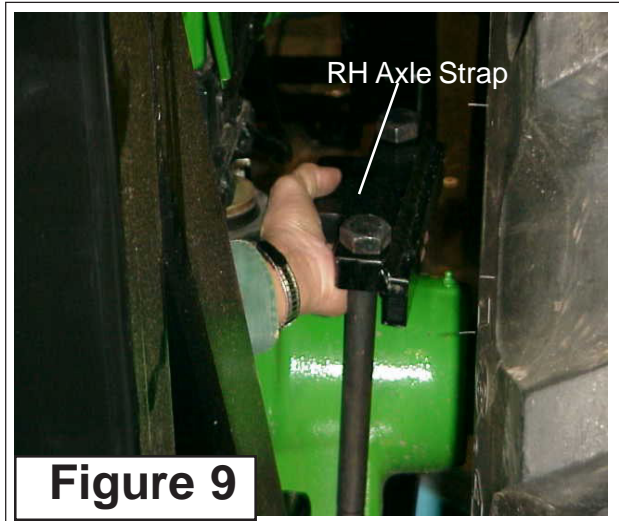


# Frame Rail Installation 4 WD

## Re-Install Frame Rails to Tractor: (continued)

6. Install Stabilizer Crossmember. This will consist of a Tube cross member and four Bolts and Nuts (**See Figure 11**). Install the Bolts with the Nuts on Top and bolts coming in from the Bottom (**See Figure 12**), this way only the Head of the Bolt is lower than the Crossmember. Snug the Bolts; do not tighten them yet.

7. Weld Stabilizer Gusset to Rail Stiffener Weldment. Weld the Gusset to the Stabilizer Weldment now, Weld on both sides of the Gusset. The LH Gusset and RH Gusset must be welded. (**See Figure 13**). Check that all Bolts and Nuts are installed.



## Frame Rail Installation 4 WD

### Re-Install High Frame to Tractor:

1. High Frame Paint. Re-Paint or Touch up Paint on High Frame now before lowering it on to Tractor. Keep in mind there will be one more Place to Weld on High frame that will need touch up Paint later, this will be the Counter Weight Lug that weld to High frame. The Lug for the Counter Weight will be installed later.

2. High Frame Mounting to Tractor. This is a two Person Job to maintain control of High Frame and guide it down over frame rails. (See Figure 14)

3. Align High Frame. The High frame with the Mounting tubes welded to it will sit down over Frame Rails. The welded on Mounting tubes will slide down into the Angle mounts that are welded to the Frame rails. (See Figure 15 & 16). Both sides must go down evenly.

4. Aligning Mounting Holes. The Holes in the Angle Mounts welded to the Frame Rail and the Mounting Tube Plates that are welded to the High Frame must be aligned. This can be done with a Pry Bar inserted into one of the holes and moved around (See Figure 17). In some cases the Frame Rails may have to be moved slightly, this is the reason the Bolts were only snugged and not tightened. Do not take Hoist off of High Frame until all Bolts are tightened. There are 8 bolts and Nuts that must be installed into the holes of the Angle Mounts. Snug these



Figure 14

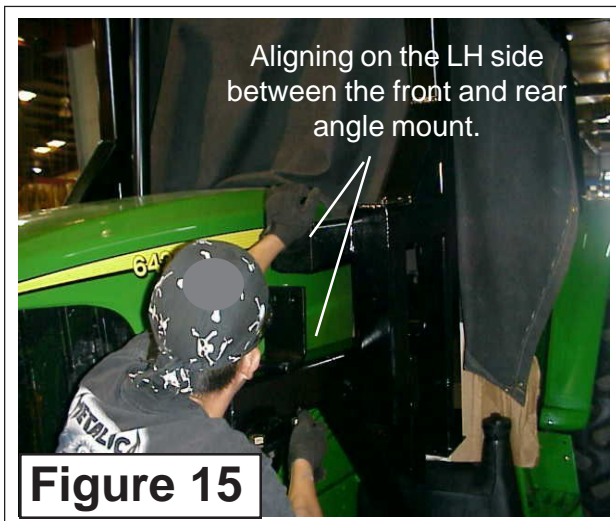


Figure 15

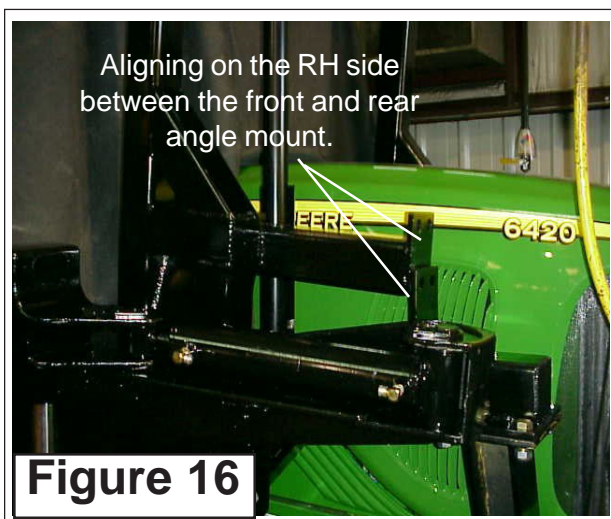


Figure 16



Figure 17

## Frame Rail Installation 4 WD

### Re-Install High Frame to Tractor: (continued)

**5. Install Mounting Tube Bolts.** The High frame must still be hung on the Hoist for safety and support, but sitting down on the frame rails. There are 8 Bolts and Nuts that go through the Angle Mounts and the Plates on the end of the Mounting Tubes. There are 2 on each end and 4 on each side. Install these 8 Bolts now but snug them only do not tighten them down yet (**See Figure 18**). You may need to insert a bar into one of the holes to align them (See **Figure 19**).

**6. Install Bar Mounting Straps.** The rear Bar Mounting Straps are the ones that were cut and welded to the tubes, just put the Bolt through these (See Figure 20). Snug the Bolt in using the Lock Nuts. The Front Bar Mounting Strap will have a strap on the Bottom and another one on the top with a bolt on each side. Install these bolts and nuts. Snug them only for now. (See Figure 21). Install the Bar mounting Straps with Bolts and Nuts on the LH and RH Side.

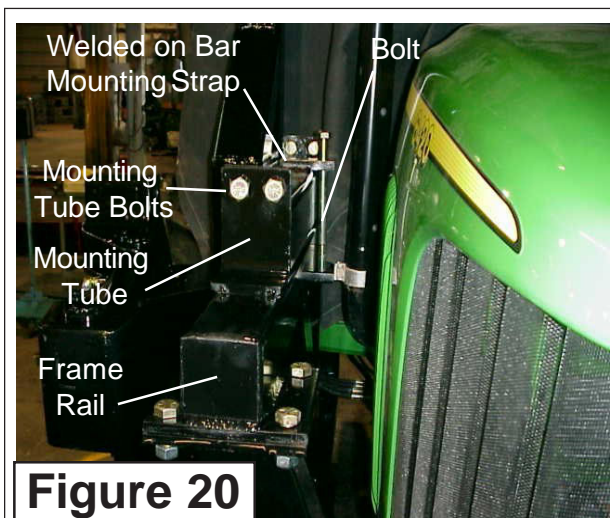
**7. Tighten Highframe Mounting Bolts.** Tighten the 8 Bolts and Nuts for the Mounting Tubes (**See Figure 18 & 19**). Tighten the Bolts for the Bar Mounting Straps, These bolts must be tighten so the straps stay even on both sides so Bars will stay even. The rear bar strap mounting bolt uses the Bars that are welded to tube and only have one bolt (**See figure 20 & 21**).



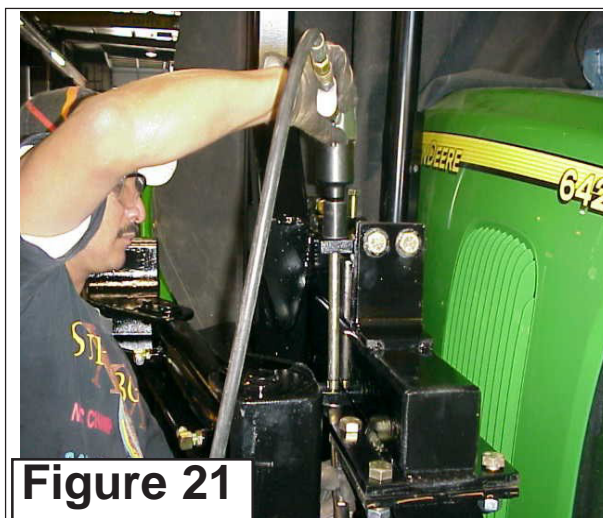
**Figure 18**



**Figure 19**



**Figure 20**

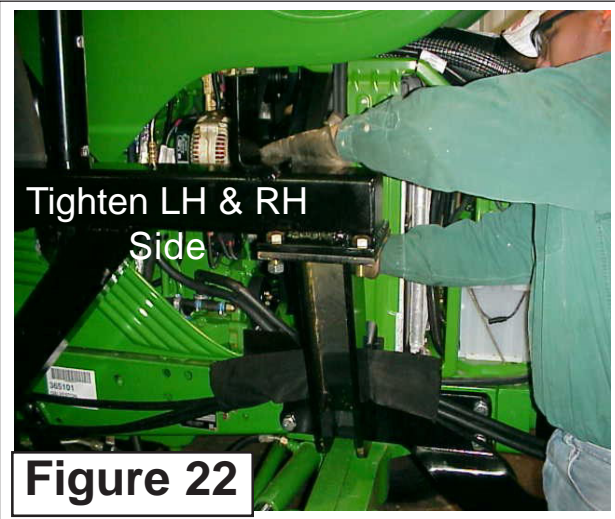


**Figure 21**

## Frame Rail Installation 4 WD

### Re-Install High Frame to Tractor: (continued)

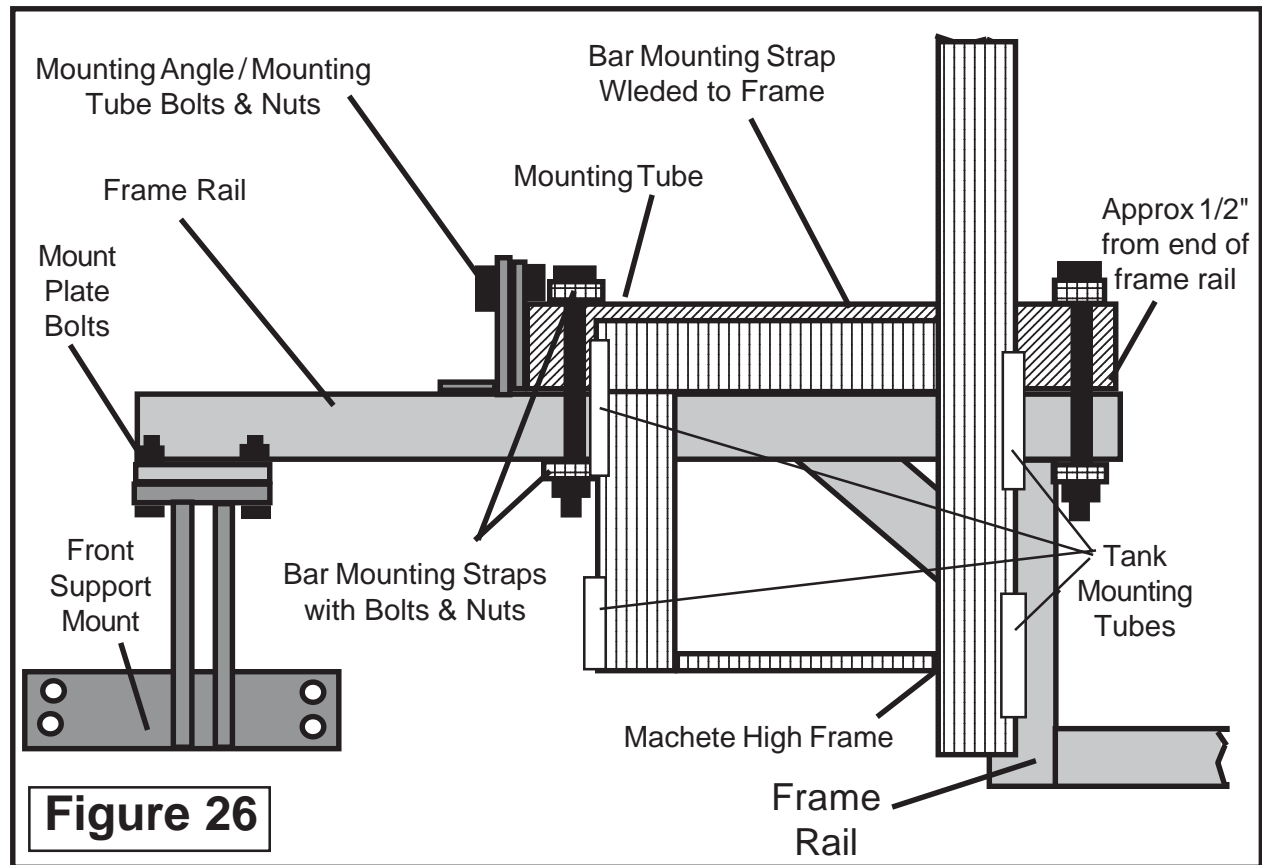
8. Tighten All Frame Mounting Bolts. Tighten all the Frame Mounting bolts that have only be snugged till now. Go through and make sure none are missed.
  - A. Front Mounting Pad Bolts. There are 4 Bolts on each Pad the LH and RH, 8 Total (See Figure 22).
  - B. Frame Stiffener Crossmember. There are 2 bolts on each side or 4 total. Make sure these bolts have been installed with the nuts on top. (See Figure 23).
  - C. Frame Rails to Rear Axles. The Rear of the frame rails bolt up to the Bottom of the Tractor Axle Housing. There is also an Axle Strap on each side which has long bolts through them from Axle Strap on top down and through the Frame rail Mount Plate. The RH side also has the Boom rest bolted on with it and the Axle Strap bolts go through it. Tighten all of these bolts at the rear axle of tractor. (See Figure 24 & 25).
  - D. Check all Bolts for Tightness. Check to make sure all Frame Mounting bolts and nuts have been tightened, Also inspect to make sure they are installed correctly (See Figures 1 through 27).



## Frame Rail Installation 4 WD

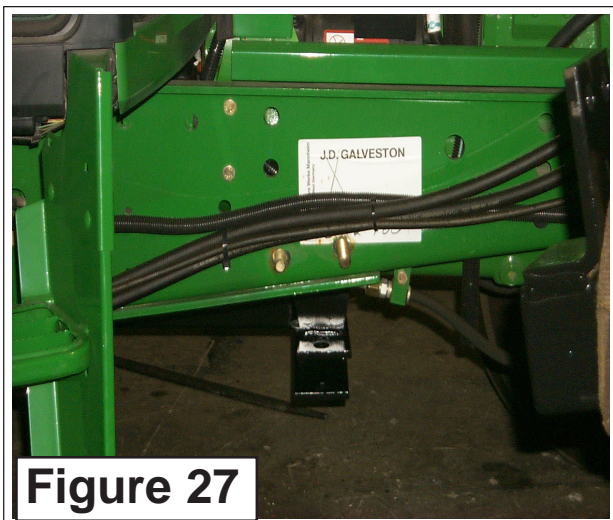
### Re-Install High Frame to Tractor: (continued)

9. Frame Mount should look like. Shown below is basically what the High Frame should look like when assembled (See Figure 26).



10. Tie Hoses to Tractor Frame Rail. Use Plastic Wire Ties to tie the Hoses and Cables from the rear of the Tractor down Frame Rails. Note: below it is shown with the Frame Rails not mounted to Tractor, this is done for illustration only (See Figure 27).

Inspect all the Hoses, Wire harness and Cables to make sure they are secured and will not be rubbed or chafed on anything. Hoses and Wire harness should not be hanging down where they will be caught on anything. If there is excess length in hoses or wire harness, gather this excess up under cab and secure it out of the way. There will most likely be excess length in these hoses and wire harness.



# Section 6

## A-Boom

### Hyd. Tank, CWT & Decal Final Installation

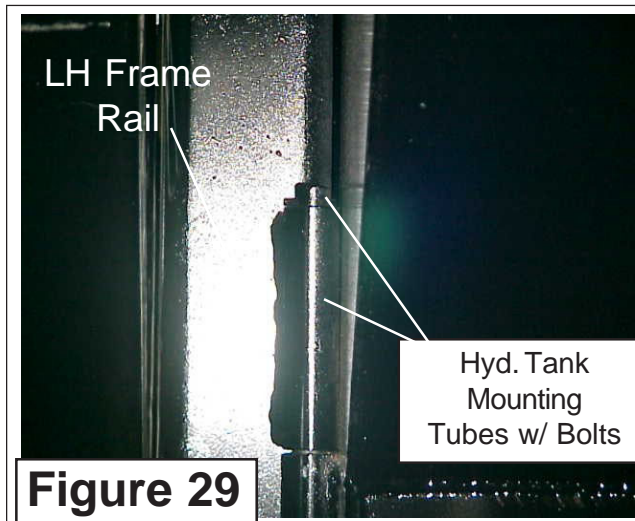
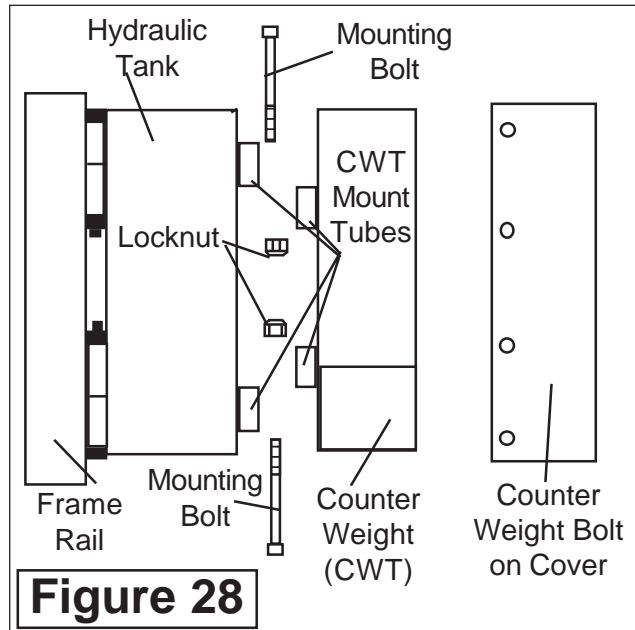
# Hyd. Tank - CWT Installation

## Hydraulic Tank Installation:

1. Caution. Care must be taken to keep Hydraulic System clean. Do not leave any openings in Tank while installing it, they must remain sealed until ready to install a component and then sealed back up.
2. Hydraulic Tank Installation. The Hydraulic Tank is shipped with the return Filter Assembly, the Suction Filter assembly is already installed in the Tank. The Hydraulic Tank is mounted on the LH side of LH Frame Rail. The Mounting Tubes are welded to the Frame rail and to the Hydraulic Tank (See Figure 28 & 29). Do not fill Hydraulic Tank with Oil until all the Hoses have been installed and tightened.

## Counter Weight Installation:

1. Counter Weight (CWT) Installation. The Counter weight (See Figure 28) mounts on the LH side and is mounted to the Hydraulic tank which mounts to the LH Frame Rail with a mounting bolts running up through tubes that have been welded to the frame rail and Tank. The Bolts must be installed as shown with the Locknuts to the inside. Installing the Bolts this way will make them easier to tighten up (See Figure 28 & 29). Install both bolts as shown (See Figure 28). Snug the Bolts, don't tighten them yet.
2. Counter Weight Cover (CWT). The Counter Weight Cover will bolt to counter weight. (See Figure 28 & 30).
3. Parts / Operators Manual Cannister. The Parts / Operators Manual Cannister Bolts to the top of the Hydraulic tank (See Figure 30). The Parts / Operators Manual should be put into cannister prior to delivery of Unit to the operator.



# Decal Installation

## Tank Oil Level Sight Gauge:

1. Oil Level Sight Gauge is mounted on the side of the tank facing the rear of the tractor. The Tank may have to have the Paint touched up, or repainted completely. Use caution not to paint over this or damage it. (See Figure 31 & 32)

## Tank Decal Installation:

1. Install Decals on Hydraulic Tank and CWT Cover. There are 10 decals that need to be installed on the Hydraulic Tank and CWT Cover (See Figure 32, 33, 34). **Counter Weight must be Installed before Boom is mounted to King Post.**

2. Decal Part Number. (See Figure 32, 33, 34)

- 1 = # 02966305, Attention - Universal Tractor Hydraulic Oil
- 2 = # 02958241, Operators Safety Decal
- 3 = # 02977417, Operators Manual Inside
- 4 = # 1458392, Red Reflector
- 5 = # 1458392, Yellow Reflector (mount in front of CWT Cover)
- 6 = # 00756059, Warning - Oil Leak
- 7 = # 02957827, Danger - Multi Hazard (Rotary) or # 002369, Danger - Multi Hazard (Flail)
- 8 = # 02965262, Warning - Hose Burst
- 9 = # 002508, Alamo Industrial Logo - Small (on front upper Tank)
- 10 = # 00769394, Alamo Industrial Logo - Large

Most Decals should already be installed when Tank Assembly is shipped.



Figure 31

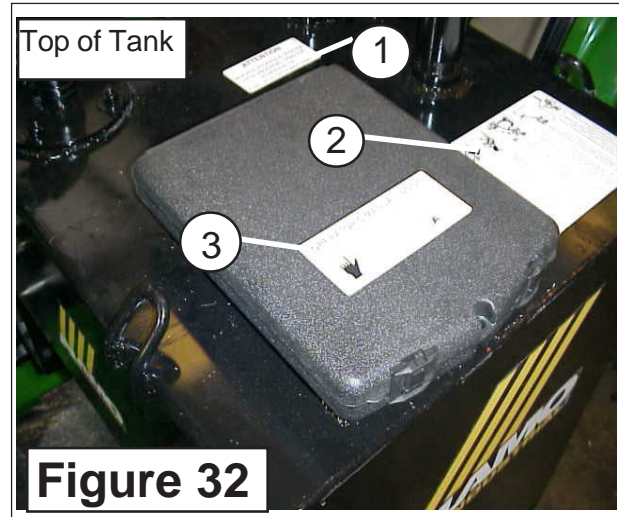


Figure 32



Figure 33

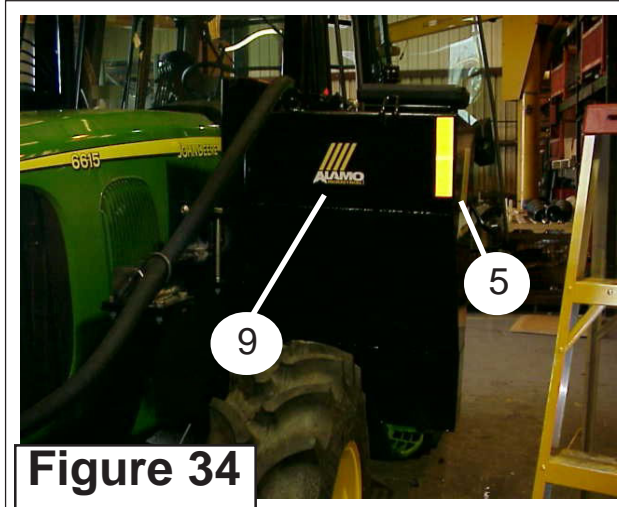


Figure 34



# Decal Installation

## Cab Decal Installation:

1. Install Decals on Windows inside Cab There are 8 decals that need to be installed on Windows and inside Cab of Tractor. Clean all surfaces before installing Decals. Do Not Install any Decals that will interfere with the Operator line of sight. (See Figure 35, 36, 37, 38).

### 2. Decal Part Number.

- 1 = # 02962107, Valve Operation - 5 Spool or # 02962024, Valve Operation - 4 Spool, (Install in lower Right Hand corner of Tractor Windshield). (See Figure 35)
- 2 = # 02967827, Danger Multi-Hazard (install in upper right corner of Left side window). (See Figure 36)
- 3 = # 02965262, Warning - Hose Burst (Install in upper left corner of Left Side window). (See Figure 37)
- 4 = # 02964677, Warning - Boom Rest (install in upper right corner Right Side Window). (See Figure 38)
- 5 = # 02963524, Attention - Boom Swing (install in upper right corner Right Side Window). (See Figure 38)
- 6 = # 00763977, Notice to Owner (install in upper right corner Right Side Window). (See Figure 38)
- 7 = # 02965093, Proper Engine Operation (install in upper right corner Right Side Window). (See Figure 38)
- 8 = # 02962748, Pull On to Start - Push to Stop, (Install on "ON" "OFF" Switch (See Figure 35)

These Decals will need to be installed by the person mounting the A-Boom, Clean all windows and make sure they are dry before installing Decals. DO NOT install any Decals in a position that will interfere with the operators view.

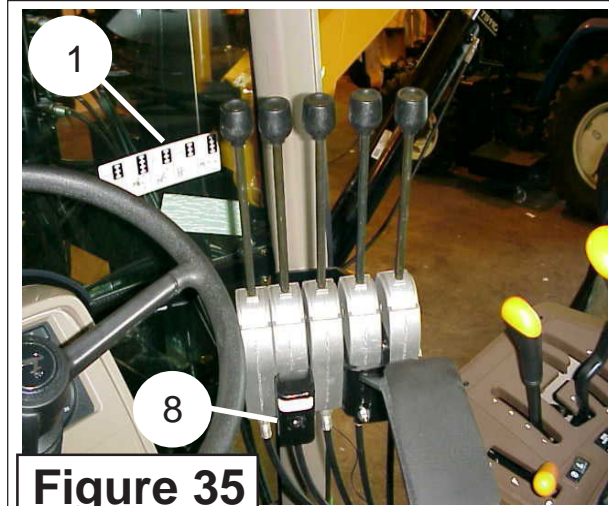


Figure 35



Figure 36



Figure 37

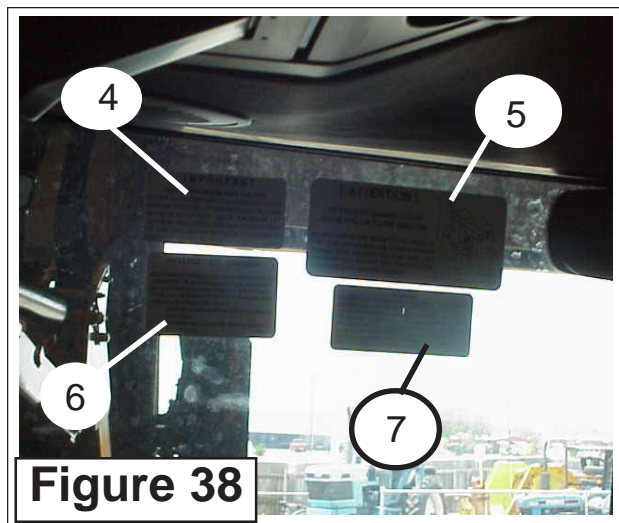


Figure 38

# Section 7

# **A-BOOM**

## **Boom Installation**

# Boom Installation

## Cutter Motor Control Valve Asy:

1. Cutter Motor Control Valve Asy. Install the Cutter Motor Control Valve Asy to the LH side of High Frame, it will not have the Hoses attached as shown, the Hoses will be connected later (See Figure 1)

## Boom Installation / Boom Hoses:

1. Hoses on Booms are shipped folded back inside Boom. Hoses must be pulled out and moved to clear, then routed in the end of Boom before installing Boom on the King Post (See Figure 2)

2. Pull the Lift Cylinder out to its full stroke, to aid in the installation of the Lift arm (See Figure 3). When Pulling Cylinder Out, attach a Hose to the Rod end and lay the Hose in a drain pan. This will catch any Oil expelled when Cylinder is pulled out.

3. With a hoist raise the Boom Arm (1) and lower onto the King Post (2). Align the Boom Arm and King Post with the Lift Hinge Point. Insert Main Pin Bolt (3) into Boom Weldment and Turning Arm. Attach Lockwasher (4), Washer (5) and Bolt (6) and tighten (also see Parts Section on the Boom Assembly) (See Figure 3, 4 & 5)

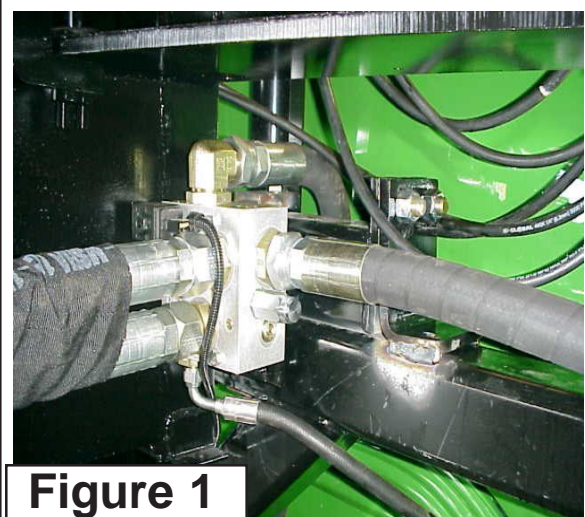


Figure 1

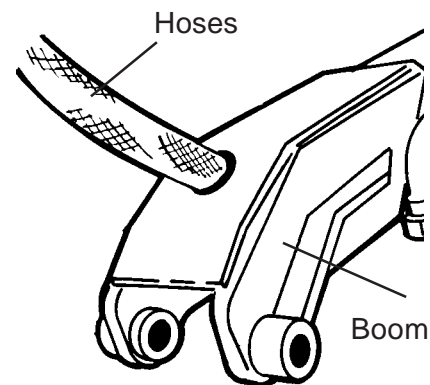


Figure 2

**Note:** Additional support may be need at the end of the Boom to aid in installation.

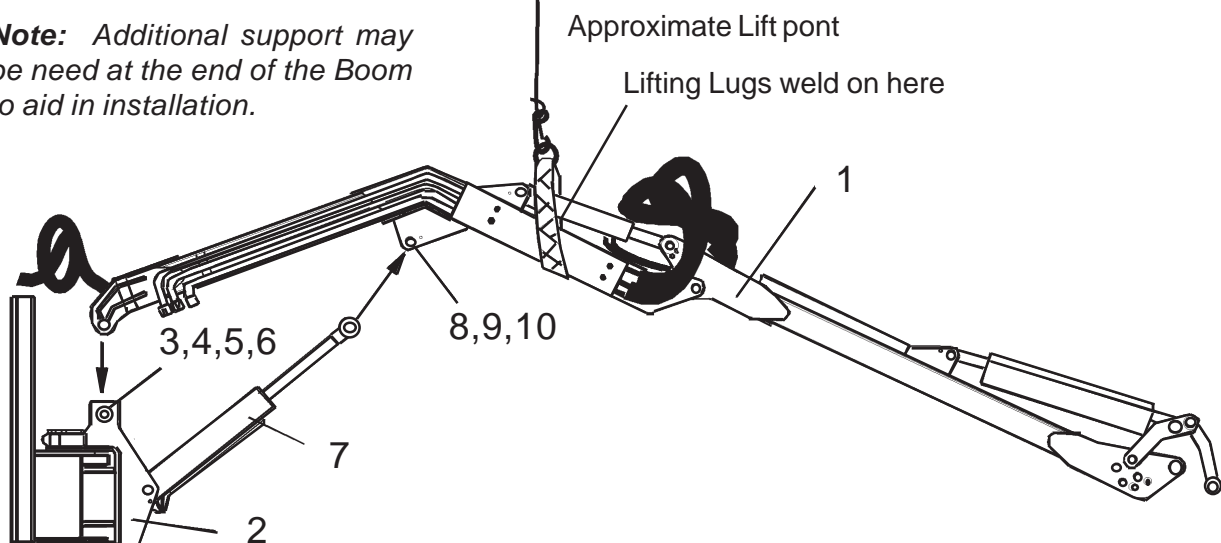


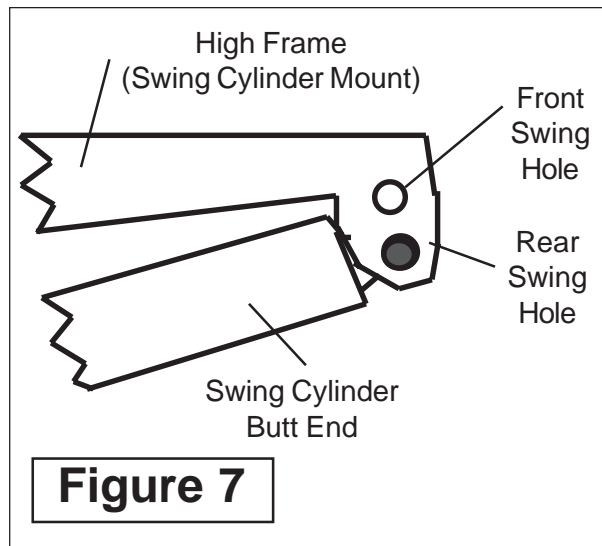
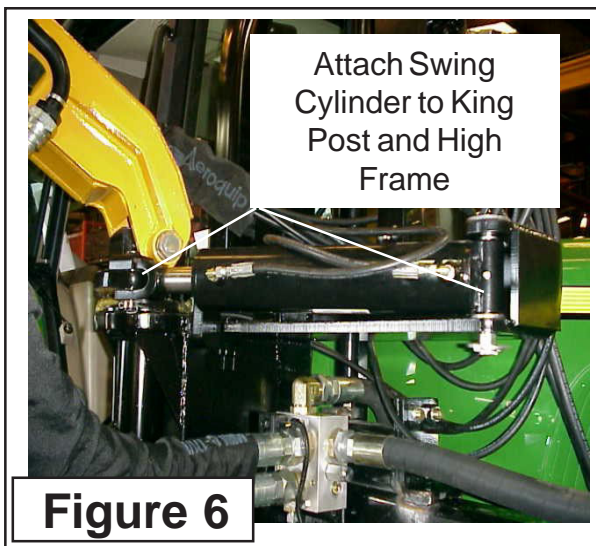
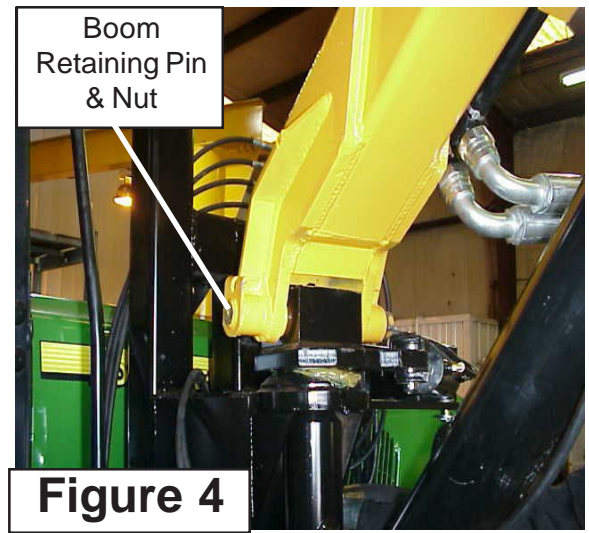
Figure 3

# Boom Installation

## Boom Installation / Boom Hoses:

(continued)

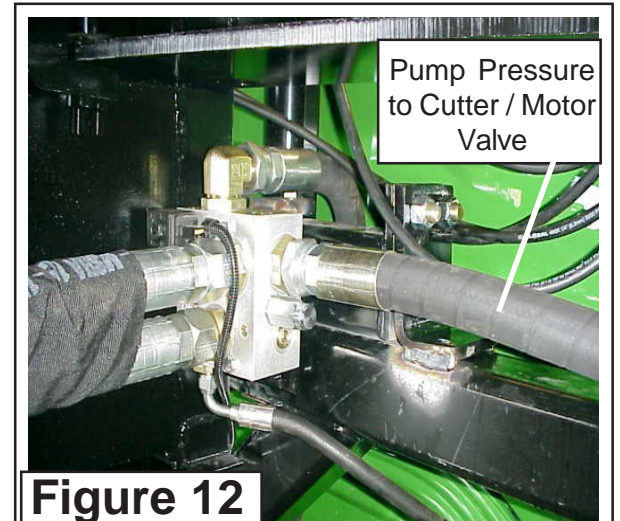
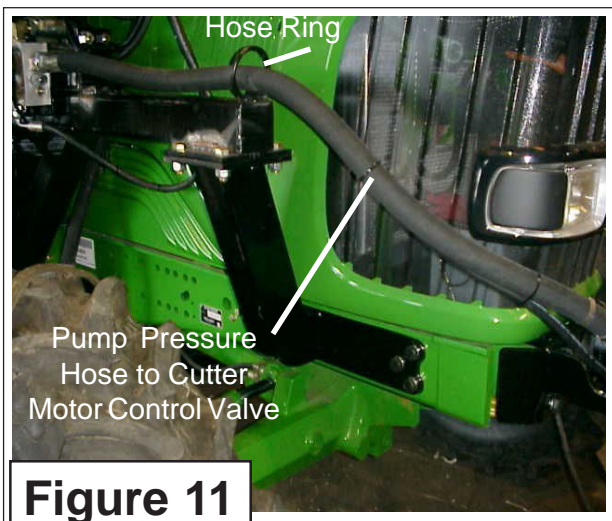
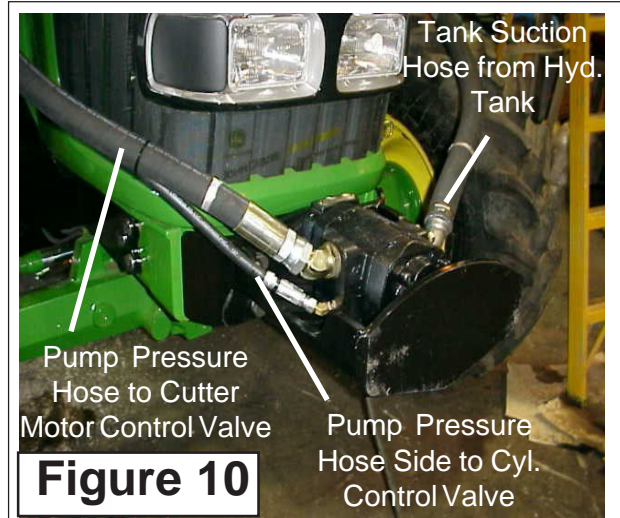
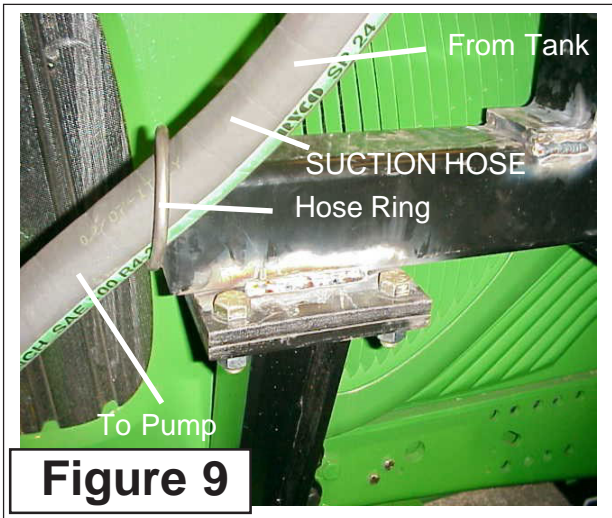
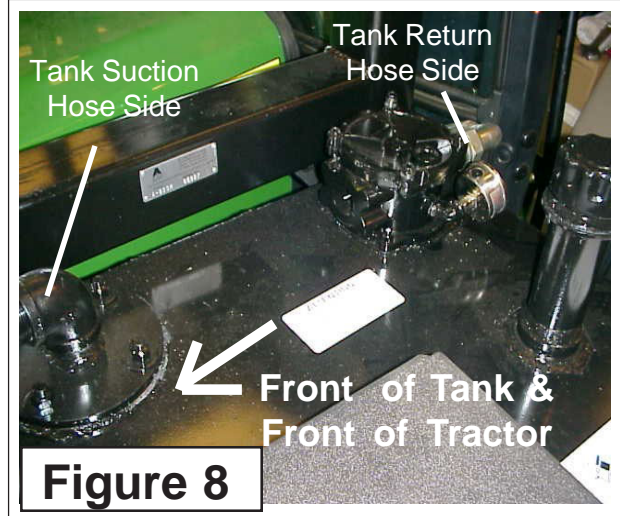
4. Attach the Rod end of the Lift Cylinder (7) to the Lift Section with Pin (8), Bolt (9) and Nut (10) (also see Parts Section on the Boom Assembly) (See Figure 3).
5. Attach the Swing Cylinder . The Swing Cylinder attaches to the King Post on the Rod End and to the High frame on the Butt end of cylinder, There are two holes on the High frame that cylinder can be connected to. The outer Hole is the one that cylinder pin should be put in for a rear swing A-Boom. A Forward Swing A-Boom is rare, majority will be rear Swing A-Boom (parks to the rear for Transport.) (See Figure 6 & 7).
6. Leave Boom Supported by Hoist until Boom is connected to King Post and all cylinders attached. (See Figure 3). The Boom will have to be lifted again when Head is installed. Do not lift Boom with Hoist if the Cylinder hoses are open, the Cylinders are built with the internal components covered with Oil. If boom is raised by hoist while these hoses are disconnected oil may be forced out of collapsing end of cylinder.



# Hose Installation

## Pump / Tank Hose Installation:

1. Suction Hose, Tank to Pump. The Suction hose connects to the front RH side of Tank (See **Figure 8**) and runs through a Hose Ring that is welded to the frame Rail (See **Figure 9**). The Suction Hose connects to the front Pump on the Left Hand Side of Pump (See **Figure 10**).
2. Connect Pressure Hoses. There are two pressure hoses that connect to the Pump. The Larger Hose (See **Figure 10 & 11**) runs through a weld on Hose Ring and to the Cutter Motor Control Valve (See **Figure 12**). The Small Hose runs to the Cyl. Control Valve. Connect the smaller hose to the pump and route with the larger hose.



# Hose Installation

## Pump / Tank Hose Installation: (continued)

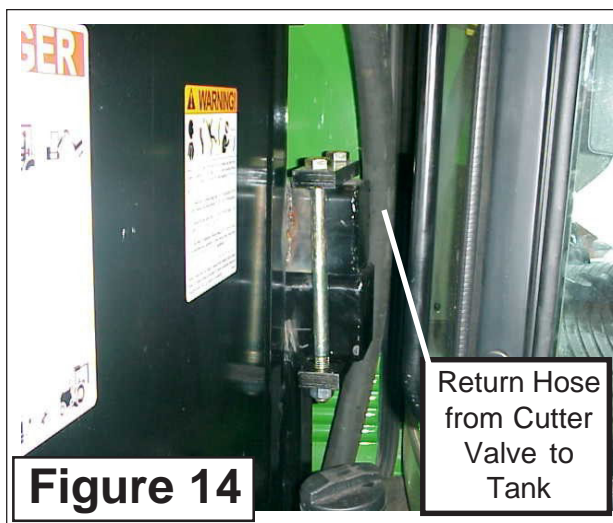
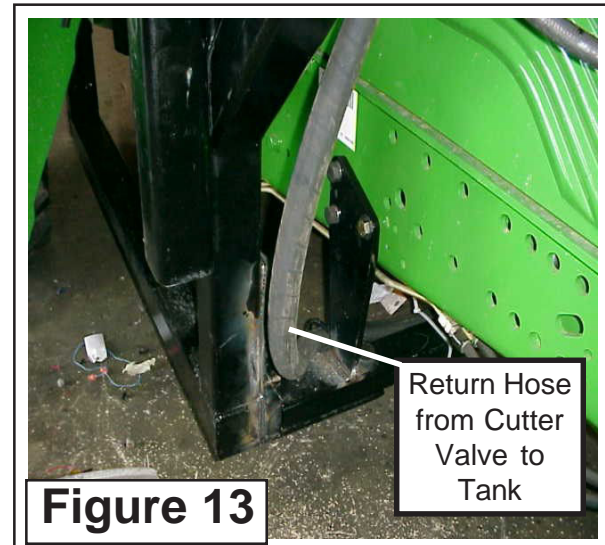
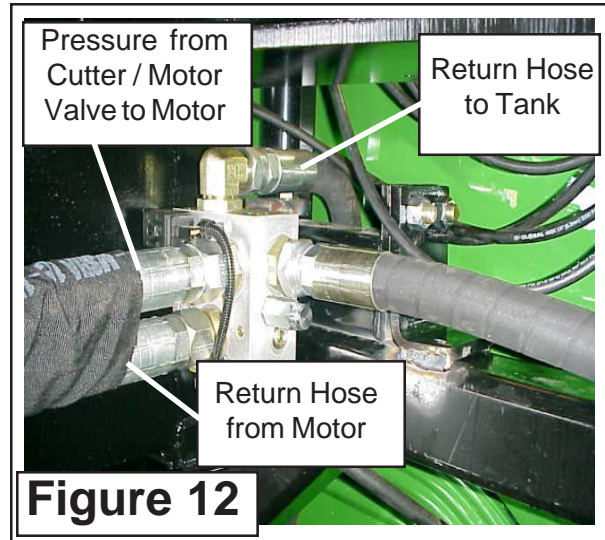
3. Connect hose from Pump to Cylinder Control Valve. This will be the small hose connection on the RH side of the pump (See Figure 10) for this hose, this hose cannot be connected to Cyl. Control valve until later.

4. Connect Hose from Cutter Valve to Motor. The Hose from the Cutter / Motor Control Valve runs down the Boom using Steel lines and Hoses (See Figure 12)

5. Connect Return Hose from Motor to Cutter / Motor Control Valve. Connect the hose from the Motor return to the Cutter / Motor Control Valve (See Figure 12).

6. Return Hose from Cutter Valve to Tank. Connect the return hose from the Cutter / Motor Control valve to the Tank. (See Figure 12). This hose will run down under tractor to the left side. (See Figure 13) and then back up the LH side to the Tank. (See Figure 14). The return hose connects to the return Filter Housing (See Figure 15).

7. Return Pressure Gauge. The Return Pressure Gauge is a low Pressure Gauge that displays uses in Green and Red Fields, Return should stay in the Green when Oil is warm and Tractor is running. (See Figure 15).



# NOTES

# Section 8

## **A-BOOM**

### **Standard**

### **Cylinder Control**

### **Valve Installation**



# Cylinder Control Valve Installation

## Control Handle Assembly Installation :

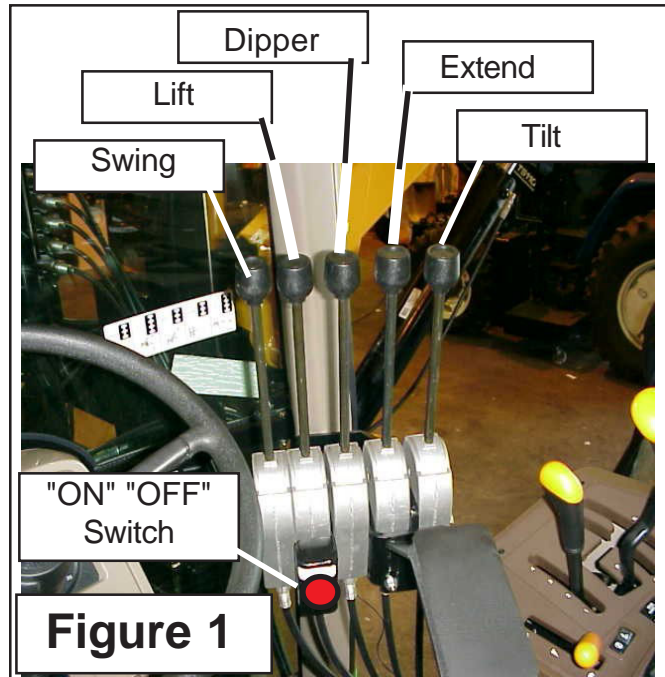
1. **The controller assemblies** will be bolted together using a tie rod bolt. The control handles are the same and the cables are the same, it is where they are connected to the control valve that makes a difference. (See **Figure 1**).

2. **The "ON" / "OFF" Switch** is bolted to the Control Handles. This is a good place but can be mounted somewhere else is desired. If Mounted somewhere else keep in mind it must be accessible quickly by the operator in case of emergency needs. (See **Figure 1**)

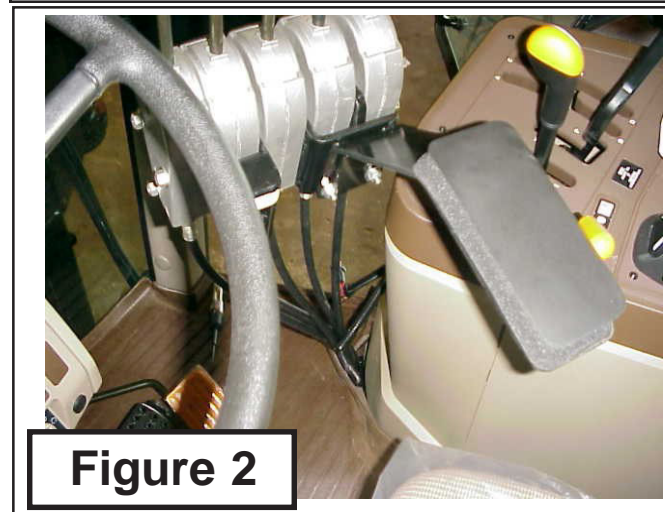
3. **The Arm Rest** is bolted to the Control Handles. This has some options as to where it is bolted and can be bent to adjust to individual preference. (See **Figure 2**).

4. **Control Handle Stand** is bolted to the floor of the Cab under the Floor Mat on the right hand side. There is a rubber plug in floor under floor mat here. remove and/or cut the rubber plug to run the cables and wire harness through it. The opening around cables through rubber plug can be sealed using silicone sealer. Floor mat will lay back down around cables and leave a small area of floor mat opening. (See **Figure 3**)

5. **Control Cables to Valve** The control cables will connect to Valve as shown in figure 3, To ID which cable is which have one person move handle inside and mark which cable moves outside. The cable connection procedure is shown. (See **Figures 4 through 14**).



**Figure 1**

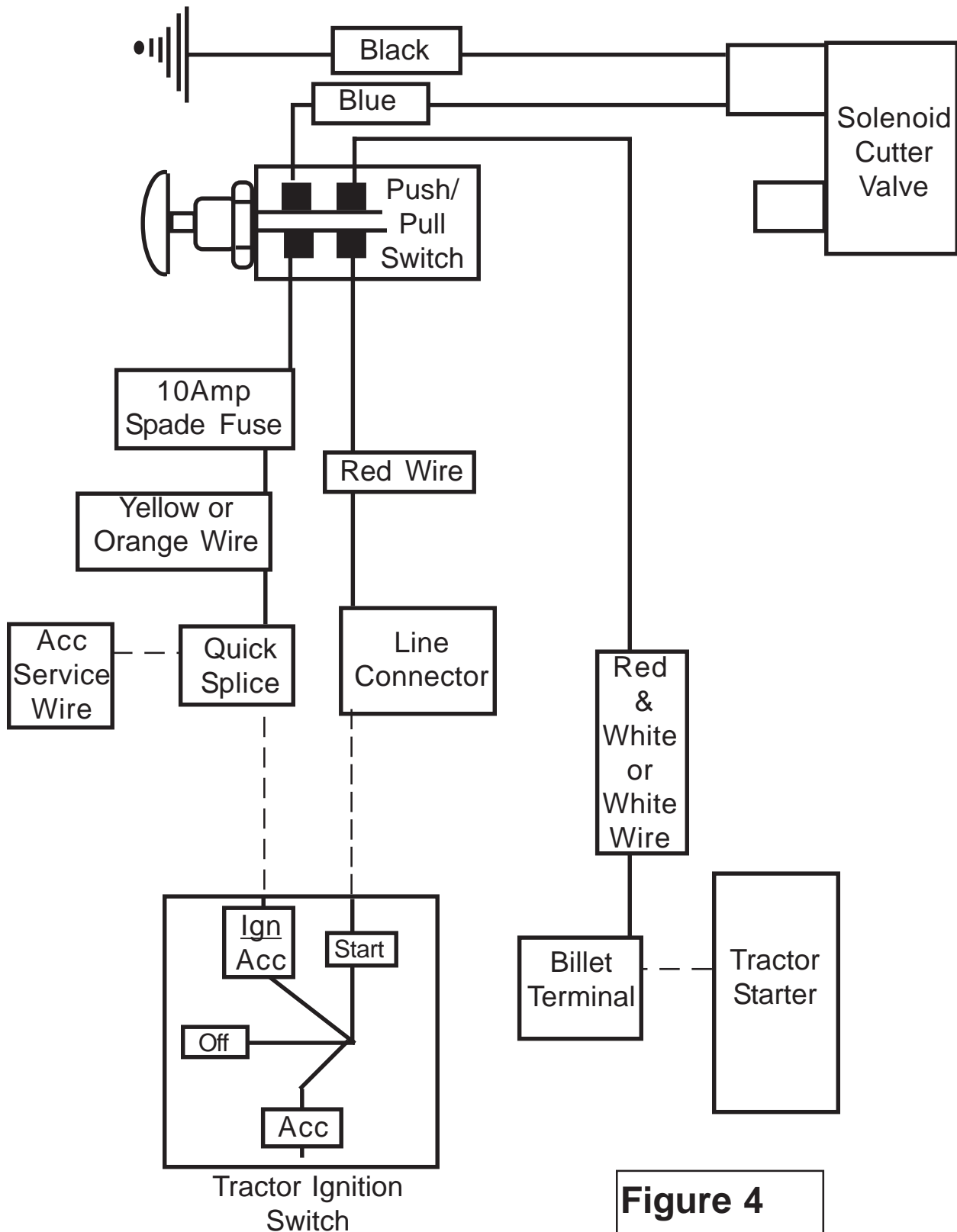


**Figure 2**



**Figure 3**

# "ON - OFF" Switch Installation



**Figure 4**

# "ON - OFF" Switch Installation

## Wire Harness: (Standard Mechanical Valve)

1. Starter Safety Switch Schematic, Mechanical Cable Operated Valve Type, NOT correct for Optional Joystick (Electronic) Controls.
2. Figure 4 illustrates a common wire harness connection for A-Boom mowers with mechanical cable controls, If the Joystick Optional controls are used the Wiring will be different than shown.
3. Individual installations may vary and are dependent on the electrical and safety system designs of the tractor to which the mower is mounted.
4. Consult the specific mounting instructions to determine the correct wire routing for each specific unit.

## Common Problems:

1. The tractor won't start: The mower on/off switch, if left in the "on" position will not allow the tractor to restart. Be sure to push the switch into the "off" position and account for all the tractor safety interlocks to enable the tractor to start. Failure of the tractor starter safety lock system is normally attributed to a failure of the mower on/off switch. Check continuity at the switch. Check for loose connections.
2. Cutter motor won't start: Normal causes of this type of malfunction include failure of the push/pull switch, failure of the solenoid coil, loose connections, loss of ground, or a blown fuse. If the mower won't start, check continuity of the system with a test light to find an electrical problem. Problems may also exist in the cutter valve and other systems.
3. The problem may not be in the electrical system, but because there are so many connections that could be malfunctioning it is the best place to start checking. If the electrical connections are ok, go on to the Tractor connections and/or the Tractor components to check for the malfunction. Some times the service technician thinks the best way to eliminate the Mower electrical connection problem is to bypass them; this should never be done, eliminating the starter safety system is dangerous and hard on the Hydraulic System, The Hydraulic System will be trying to start at a low RPM which is not good.

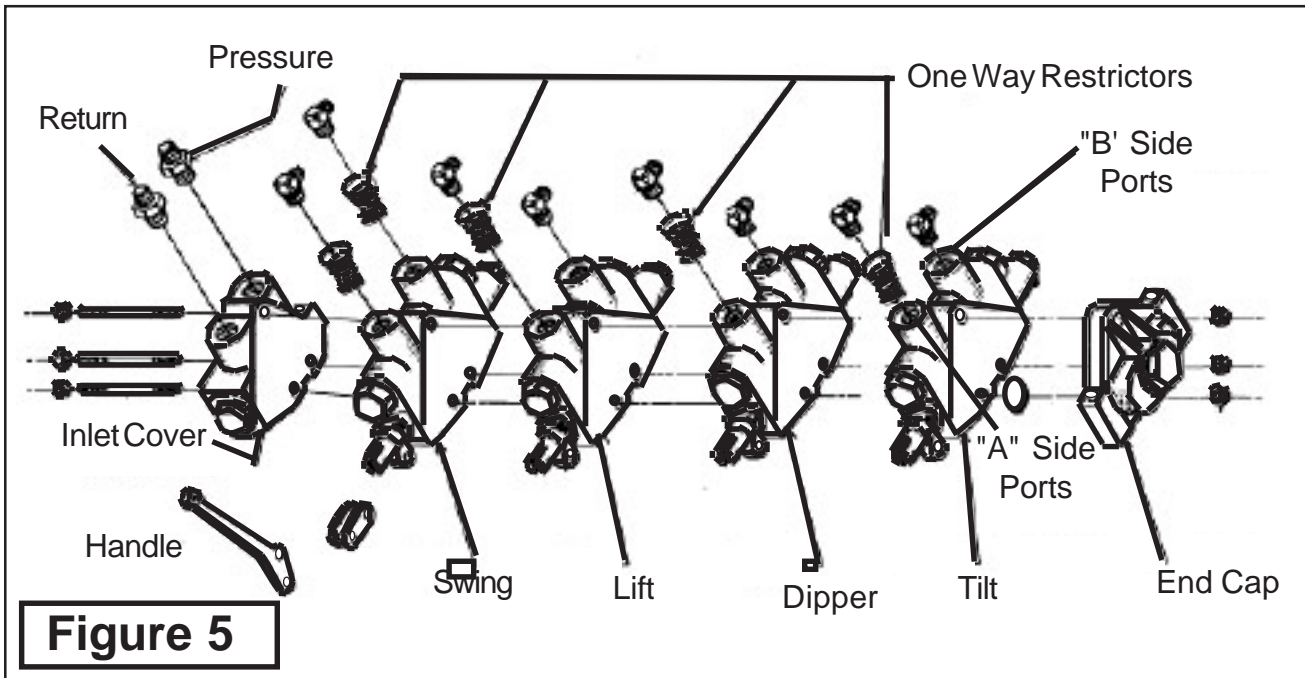
## Standard Control Valve Operation:

1. This Control valve is the Standard 4 Spool that is remote cable Controlled, The 28 ft model used a 5 Spool valve with the 5 Th. Spool operating the Boom Extension. THIS SECTION WILL NOT apply to the OPTIONAL ELECTRONIC JOYSTICK CONTROLS. This Section mostly shows the 4 Spool Valve, The 5 Spool Valve is mainly the same with the 5 Spool operating the Hydraulic Door option on the Rotary head or the Boom Extension Cylinder on the 28-ft Model. (See Figure 5 & 6)

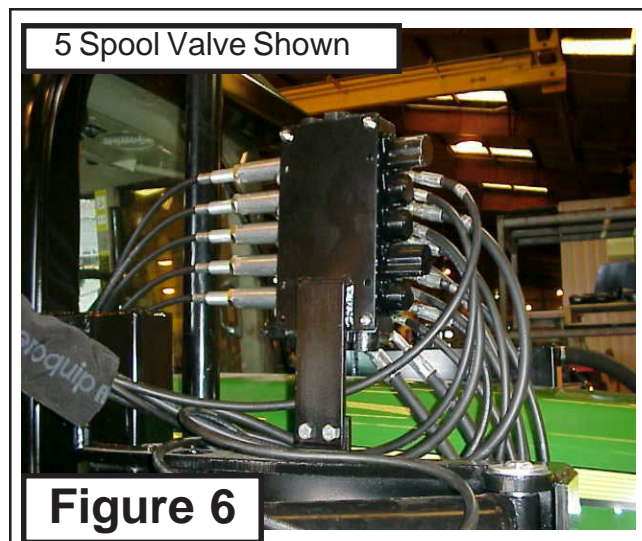
# Cylinder Control Valve Installation

## Standard Control Valve Operation:(continued)

2. The Standard Tandem (Dual) Pump System is Shown, there is a Single Pump System Option available. The Single Pump only supplies the Hydraulics for the Cutter Head Motor and the Tractor Hydraulic System is used to supply the Boom Cylinder movements. The Schematic is very much the same except the Cylinder Control Valve Hose connections are run to and from the tractor instead of the way they are shown in the Schematic on the next page. (See System Schematic drawings for Pump Repair Section)



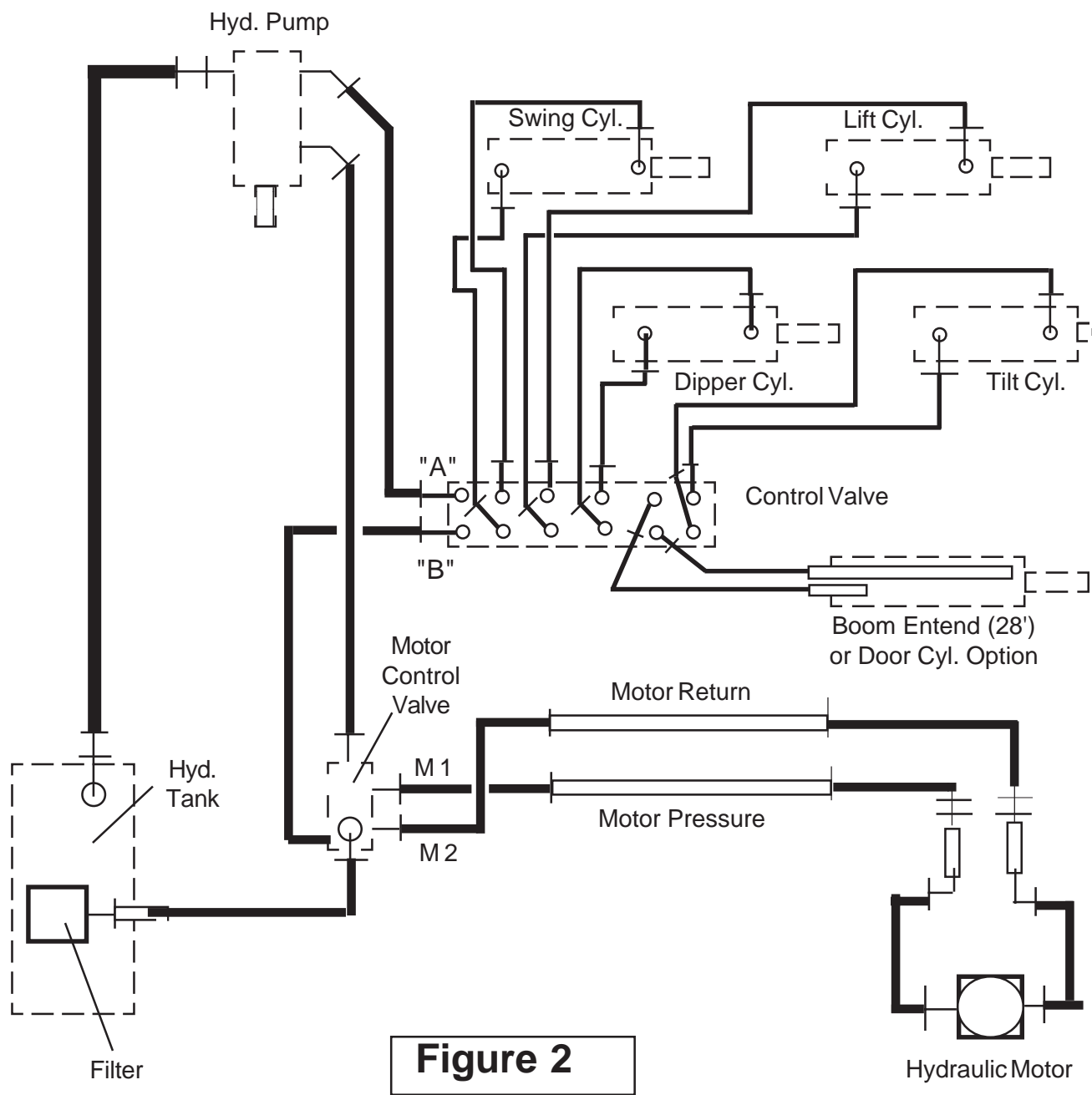
3. The Control valve will bolt on the top of the High Frame on the right hand side. There is a tab welded to the Frame that has two holes in it, the Valve mount plate will bolt to this tab and the valve will bolt to mount plate (See Figure 6) The Valve in Figure 6 shows the Hoses and Control Cables already connected, this is for illustration only. The Control Cables and Hoses are connected after the Valve is bolted to the mount plate. Most of the Hoses shown in figure 6 are running from the Boom. These Hoses must be connected to the correct Port on the valve and to the correct side to operate correctly.



# Cylinder Control Valve Installation

## System Schematic

(Typical 17' through 23' with 4 Spool Valve)



**Figure 2**

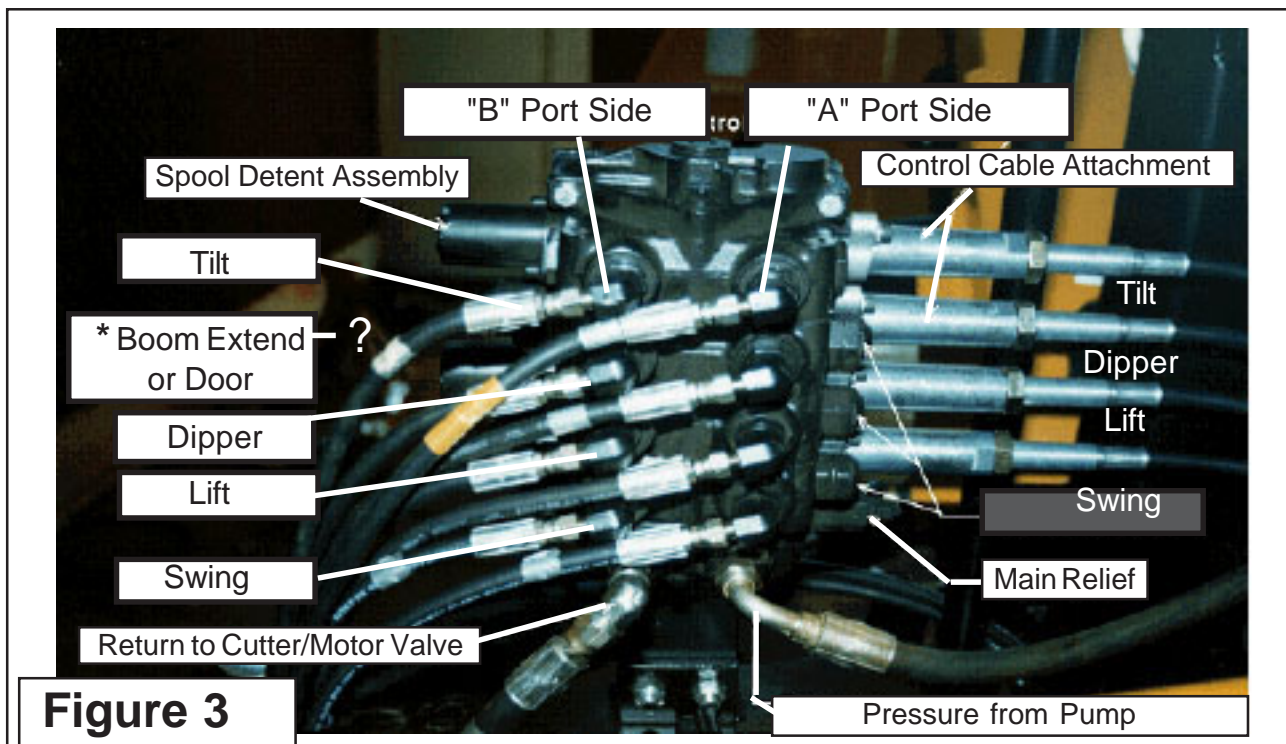
### Cylinder Hydraulic Control Circuit: (See Figures 2 & 3)

The Hydraulic Schematic above shows a 5 Spool System, The 4 Spool System is the same with the exception the 5th spool which is installed between the Dipper and Tilt Cylinder Spools. When you assemble this you will not have to assemble the Valve, it will come to you already assembled as a 4 Spool or 5 Spool depending on which model and which option you ordered. Hoses must be connected to the correct Valve Port so the Control Functions will operate in the correct direction.

# Cylinder Control Valve Installation

## Cylinder Hydraulic Control Circuit: (See Figure 2 & 3)

1. Hydraulic power for the cylinder control circuit is taken from the second (smaller) stage of the hydraulic pump. Oil is supplied through hose 2 to the four (or five) spool control valve where it is directed to the appropriate cylinder through the cylinder hoses. All of the cylinders are double acting. The system is protected from excessive pressure by an adjustable pressure relief valve located on the inlet section of the valve. The pressure relief valve is factory set at 2000 PSI for the 17, 20, & 23 foot booms and to 2500 PSI on the 28 foot booms. In addition, at least 3 individual cylinder circuits are protected by a non-adjustable work port relief valve (See Specifications in the Service repair Manual).
2. One way restrictors are added to the valve sections such that the return flow from the cylinders when performing gravity aided function will slow the flow of return oil and allow for a more controllable movement of the boom. (See the specifications for size of restriction and location in the Service repair Manual).
3. Oil is returned from the valve through Return hose to the Cutter / Motor Control valve where it then passes through Return hose into the return filter and into the tank.
4. The valve utilized on the A-Boom mowers to facilitate the control of the boom movement functions is either a **\* 4 Spool or \* 5 Spool**, open center, sectional, manually operated valve. The manual operation is performed with the use of normal directly attached valve handles or through the use of cables and remote mechanical levers. **\* The 5 Spool** has one more Spool than shown below, it is to operate the Boom Extension on the 28 ft; Boom or to operate a hydraulic activated Door on some heads. The 5th spool will be located between the Dipper and Tilt Spool shown in **figure 3**. (See Figure 15 later in this book)
5. Although similar in appearance, each valve section is specifically designed to perform the specified function for which it is assigned. The Valve is shipped assembled and should not be disassembled during unit assembly.



**Figure 3**

# Cylinder Control Valve Installation

## Cylinder Hydraulic Control Circuit: (continued)

**6. Hydraulic Cylinder Hoses.** The Hoses for the Hydraulic Cylinders will be marked with bands that have the Part Numbers on them. These part numbers will vary with the size of the Boom Model. The 28 ft. model will have more hoses for the Boom Extend Function, the model with the Hydraulic Door on cutter head will have more hoses. To find which Hose you have you will need to consult the Parts / Operators manual. When connecting the Hoses to The Valve use these numbers to connect the correct hoses to the correct ports. It may be required that you do some tracing of hoses to find which hose is hooked to which end of a Cylinder. Listed below is a list of which end of Hydraulic Cylinder should be connected to which Port on valve. **(See Figure 2 & 3)**

### MECHANICAL VALVE MODELS

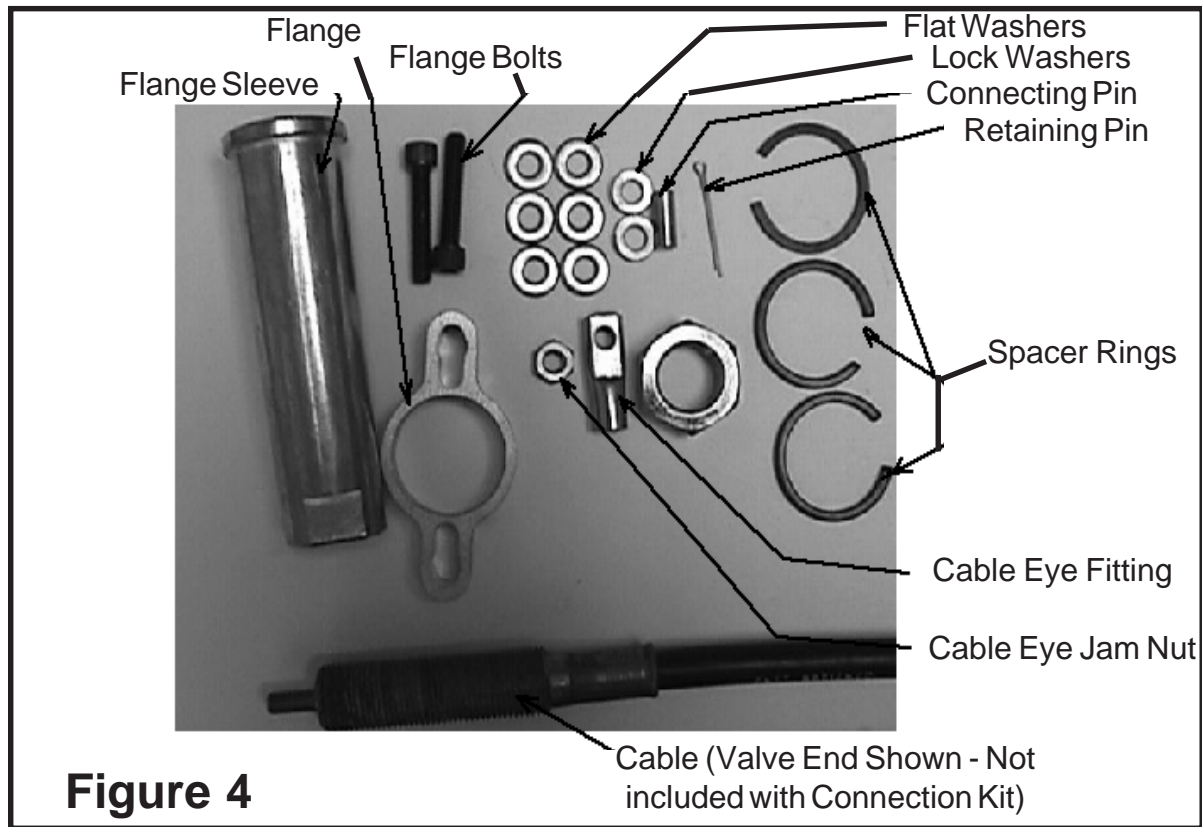
Cylinder	Rod End / Port	Base End / Port	
Tilt	("B")	("A")	Standard
Extend / Door	("B")	("A")	Only used with 28' Model or Optional Cutter Door)
Dipper	("B")	("A")	Standard
Lift	("A")	("B")	Standard
Swing	("A")	("B")	Standard

You must consult the Parts Manual to determine correct Hoses used on the Model you have. Also the type Head used will make the Hose vary. There is a Electrical control valve Option, this will make a difference of which hose is connected where. If the hoses are connected to the wrong side of valve it should not damage any thing, it will mean that the control lever function will be reversed or may not work at all because the Relief Valve is in the wrong direction of Oil Flow to operate.. Changing the Hoses on the hose ports of the valve will change this.

### REMOTE CABLE OPERATION AND INSTALLATION:

1. Remote operation of the boom movement control valve can be achieved with the use of cables and remote actuator handles. The remote operation system is standard equipment on cab tractor units and can be installed on ROPS tractors as well (See Figure 4). Four cable lengths are available and should be ordered based on the length required to reach from the valve to the Operator's location with out binding or kinking. Cable lengths are limited to 48,60,72 and 102 inches.
2. To install the cables to the valve, each valve section will require a cable installation kit (4 kits for a 4-spool valve, 5 kits for a 5-spool valve etc.). Each individual valve connection kit can be ordered using part number 02971274. **Figure 4** displays the contents of each kit. Cables are not included in Cable Connection Kit.

# Cylinder Control Valve Installation



3. Turn the Jam Nut and the Flange/Sleeve Assembly onto the threaded cable end to the entire length of the threads. Cables are not included in Valve connection Kit. (See Figure 5).



**Figure 5**



# Cylinder Control Valve Installation

## REMOTE CABLE OPERATION AND INSTALLATION: (continued)

4. Turn the cable eye Jam nut on the threaded cable end until it bottoms. Thread the Cable Eye onto the cable end until it bottoms on the cable. Turn the eye to align with the spool end and secure the jam nut against the cable eye. (See Figure 6).

5. Slide the cable eye into the slot in the spool and align the holes. Insert the connection pin and install the retaining pin into the hole in the connecting pin and secure by bending both ears of the retaining pin back and around the connecting pin. (See Figure 7).

6. With the cable attached to the valve, turn the Flange/Sleeve Assembly back onto the threaded cable end until it is flush with the valve face. **When turning on the assembly, make sure that the valve spool remains in the neutral position.** (See Figure 8).

7. Tighten the Jam Nut onto the Flange/Sleeve Assembly to lock it into position. (See Figure 9)

8. Tighten the Flange into position using the two allen head screws. Use a flat washer to support a lock washer on each bolt. (See Figure 10)

9. Interference will occur between the Flange/Sleeve Assembly and the casting of the Inlet Section on the Valve Section next to the Inlet Section. To compensate, the provided shims should be placed on the Flange/Sleeve Assembly under the flange (See Figure 11)

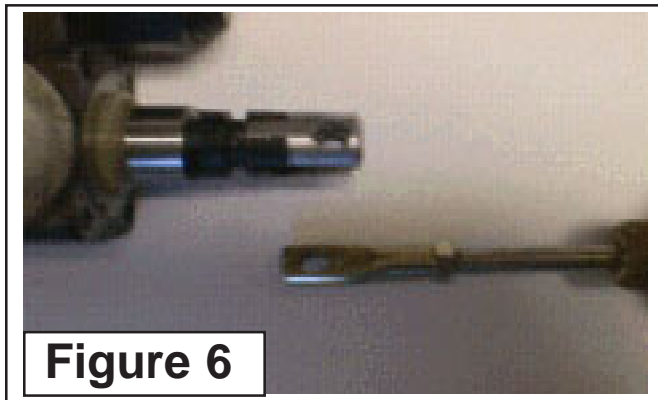


Figure 6

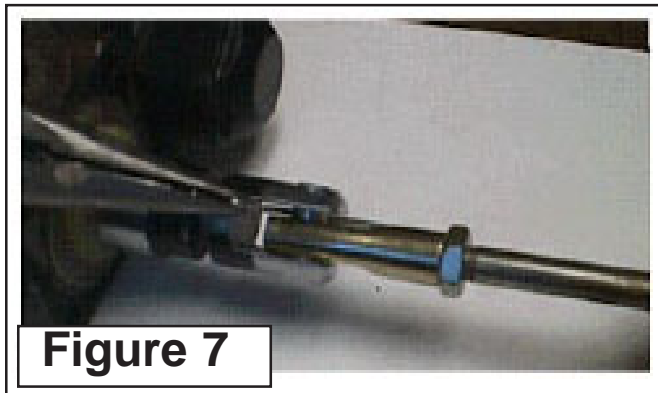


Figure 7



Figure 8

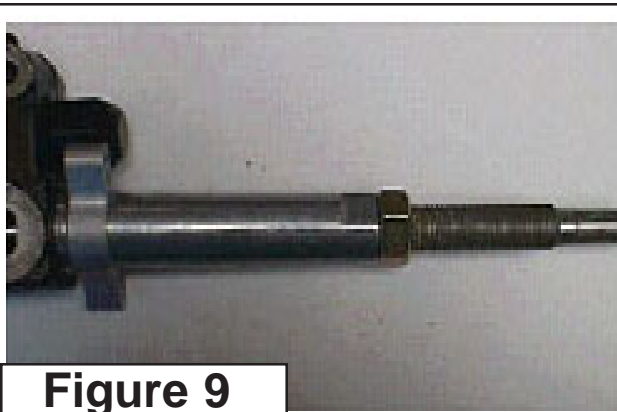


Figure 9

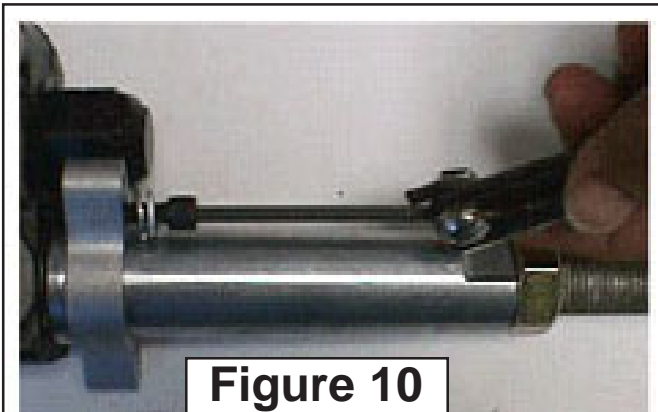


Figure 10

# Cylinder Control Valve Installation

## REMOTE CABLE OPERATION AND INSTALLATION: (continued)

**10.** Each cable is controlled by the operator with the use of single axis control handle assemblies. A single control handle assembly is required to operate each individual valve section. The control handle assemblies are ordered as PN 02971243

### Control Assembly - Controller End - Installation Procedure:

**1.** Each controller assembly comes fully assembled. All required hardware etc. is included. The control cables are not included with the control handles and should be ordered separately. The Controller must face forward as shown or controls will be backward (See Figure 12)

**2.** To attach the cable, manipulate the controller handle so that the attachment nut is exposed as shown. Remove the lower most nut and screw from the controller housing. Thread the cable nut into the controller attachment nut and tighten. (See Figure 13)

**3.** Allow the controller handle to return to neutral. Slide the cable guide tube into the control housing and reinstall and tighten the housing screw.

**4.** Check the operation of the spool, cable and controller. Some adjustment at the valve end may be required too ensure that the spool returns to neutral when the controller is in the neutral position. (See Figure 14)

**5.** The control lever assemblies utilizes a small spring to make up for free play in the cable to valve connection. The control valve spool spring provides the centering capabilities of the controller and the valve spool. **Lack of centering at the controller is normally attributed to poor adjustment at the valve to cable connection or binding of the cables due to poor routing.**

**6.** The control lever assemblies will bolt together to form a group of handles, there will be 4 for thr 4 spool valve and 5 for the 5 spool valve. Also the "ON" and "OFF" Switch will bolt to the Handles (See Figure 15)

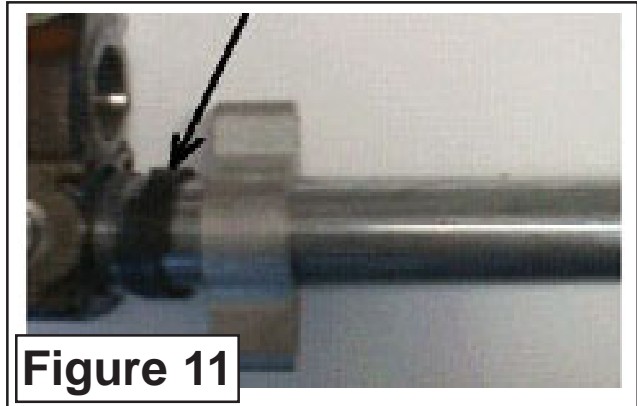


Figure 11

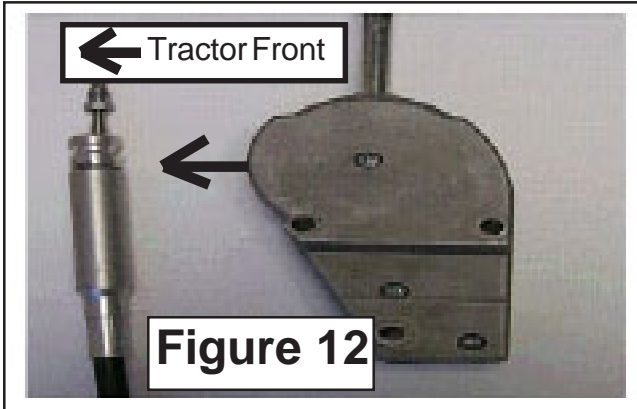


Figure 12

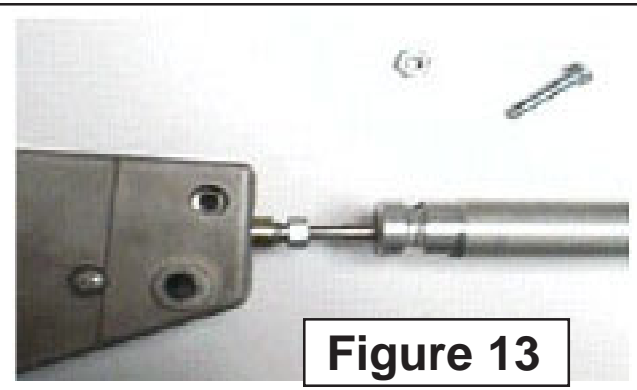


Figure 13

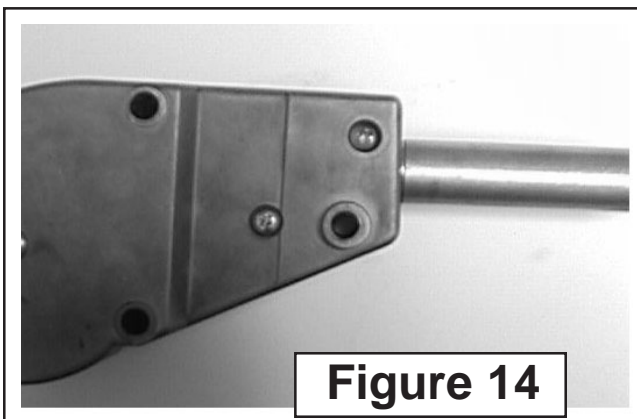


Figure 14

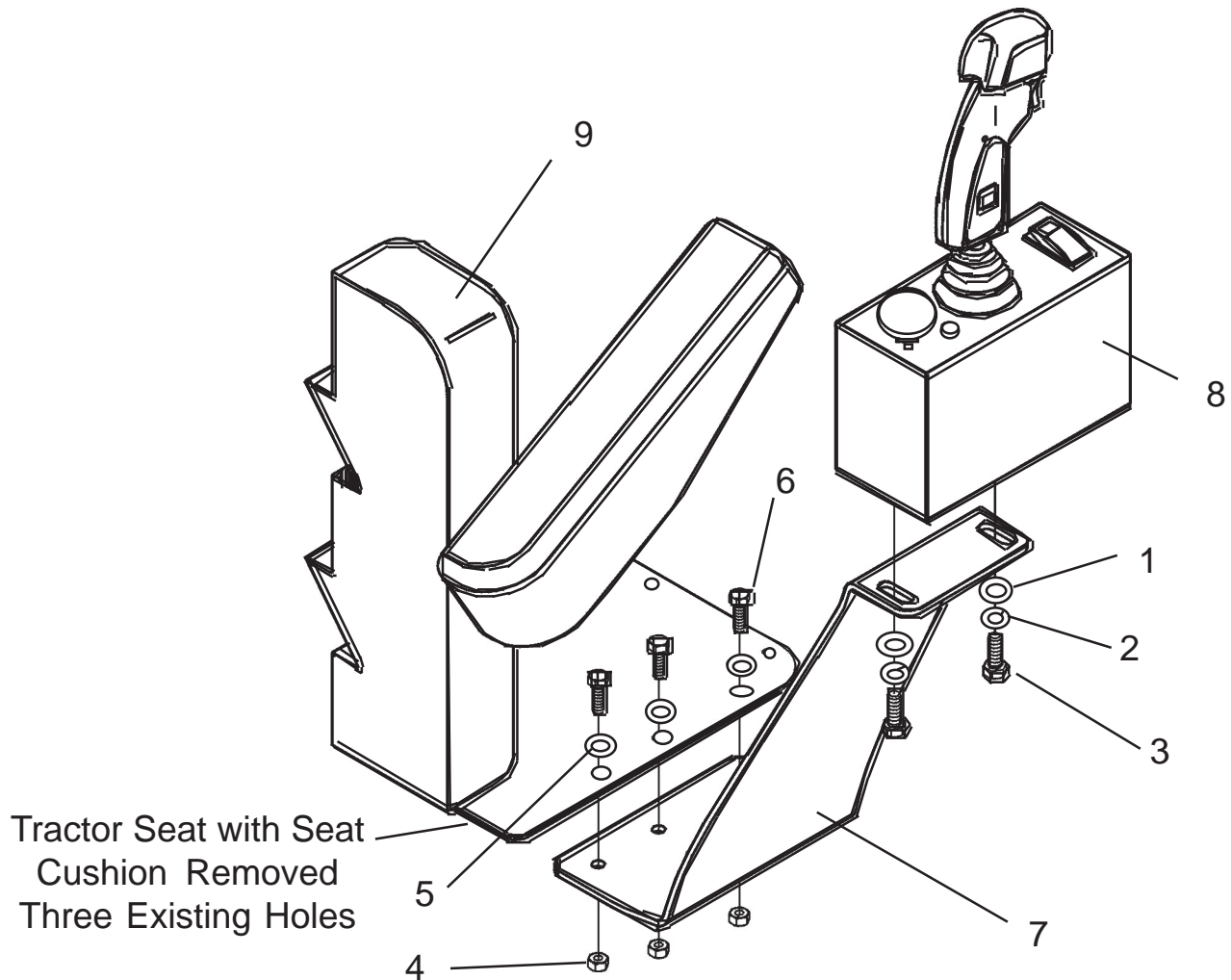
# NOTES

# Section 9

## **A-BOOM**

### **Optional Joystick - Wire Harness & Valve Installation**

## Optional Joystick Mounting



**FIGURE 1**

Item	Part No.	Qty	Description
1	00011100	2	Flatwasher, 3/8"
2	00012101	2	Lockwasher, 3/8"
3	00011400	2	Bolt, 3/8" NC X 1"
4	00750940	3	Locknut, 5/16" Toplock
5	00023500	3	Flatwasher, 5/16"
6	10119000	3	Bolt, 5/16" NC X 1"
7	02978806	1	Bracket, Seat Mounted Joystick
8	-----	1	Joystick (Shown as Illustration Only)
9	-----	--	Tractor Seat

## Option Joystick Mounting

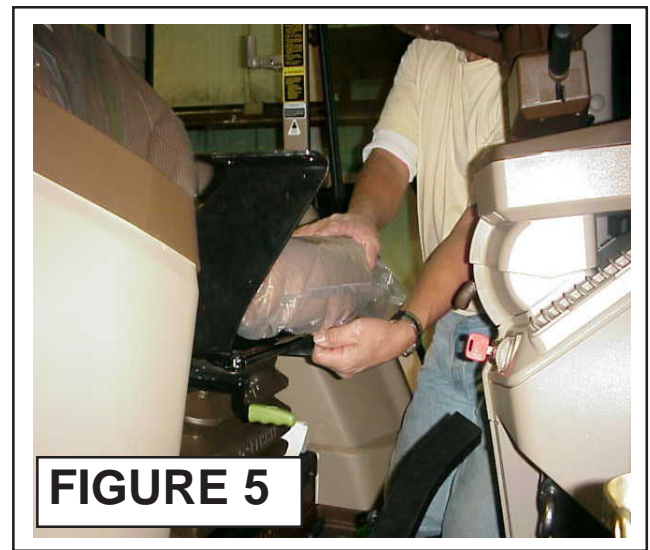
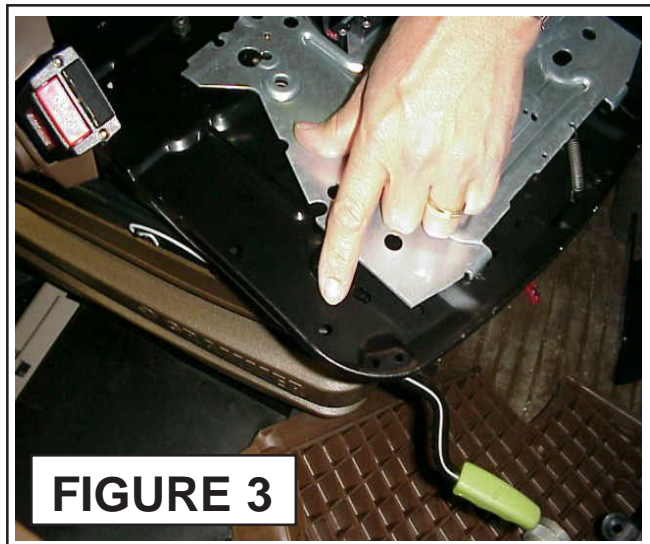
### Installing Joystick Mount to Tractor Seat:

1. **Remove Tractor Seat Cushion.** Remove Lower Seat Cushion from Tractor Seat. The Seat Cushion should have three phillips head screws across the front edge (See Figure 2). Once these screws are removed, lift up on the front of the Seat Cushion which should slide forward and out.

2. **Joystick Bracket mounting holes.** The three mounting holes are already in the Standard Seat Mounting Plate. If a custom Seat or for some reason these three holes have to be drilled, use caution not to drill them in to where the bolts will interfere with the Tractor Seat Slide Adjustment Rail.

3. **Bolt Mounting Bracket to Seat.** Insert the three 5/16" Bolts with Flatwashers on them through the holes in the Seat Plate (See Figure 4). The Mounting Bracket is under the Seat Plate as shown in the drawing. Install the three 5/16" Lock-nuts on the Bolts from the Bottom. Tighten the three Bolts and nuts.

4. **Re-install Tractor Seat Cushion.** Re-install Tractor Seat Cushion in reverse of step 1. Test Seat to make Sure that it does not bind when slid forward or back as adjustment. If there is a Bind, check and correct problem.



# Joystick Mounting 2 WD & 4 WD

## Installing Joystick to Bracket:

- 1. Bolt Joystick to Mounting Bracket.**  
Set Joystick Assembly on Mounting Bracket. Make sure Joystick is mounted as shown, the Push Pull Switch in rear and Toggle Switch to the front. (See Figure 6)
- 2. Installing Joystick Mounting Bolts.**  
Find the two 3/8" bolt, put Lockwasher and Flatwasher on them. Start these bolts from the bottom up through Bracket and into Joystick Console. The Joystick Console holes are threaded so no Nuts are needed. Tightened the two retaining Bolts (See Figure 1 Item 3 and Figure 2).



## Installing Wiring Harness for Joystick:

- 1. It is recommended** that the Wires for Joystick be connected at the Tractor Ignition Switch. But they can be connected as explained below. If connected as shown below Wires must be traced to find the correct wires.
- 2. Preparing Tractor Floor Mat.** First thing to do is remove the Battery Cables from Battery, Do Not perform any work on Tractor unless this has been done. Raise the Floor Mat up on the RH Side by the RH Door, You will need to fold it back approx. 12 to 14 inches (See Figure 8). DO NOT Tear or Cut any Holes in Floor Mat, as it will NOT be required. You will also find a large oblong shaped rubber plug, this will be pulled up later but it is not necessary at this time.
- 3. Tractor Wiring Harness.** Under the Floor Mat on the right hand side you will find a Tractor Wiring Loom Running across Floor, remove the plastic cover that is over the wire loom. Using Tractor Manufacturers Service Manual Identify Which Wire is in this Loom.



## Joystick Mounting 2 WD & 4 WD

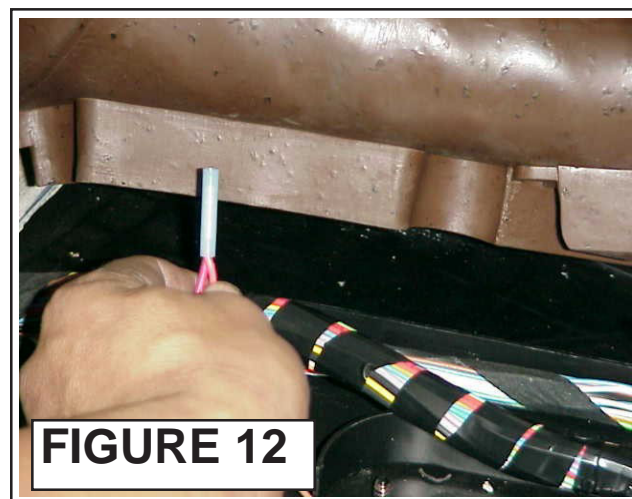
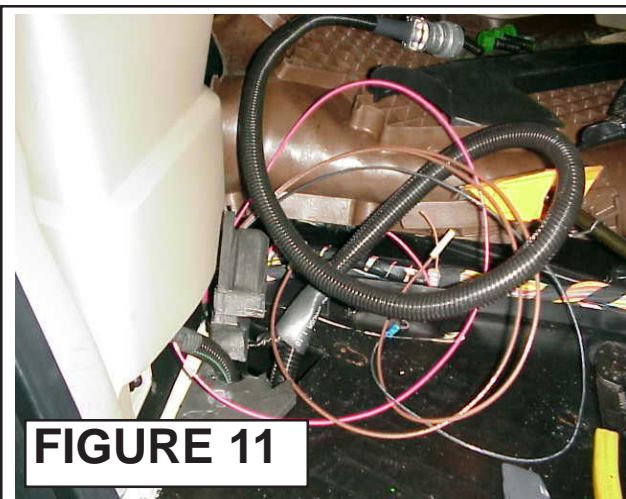
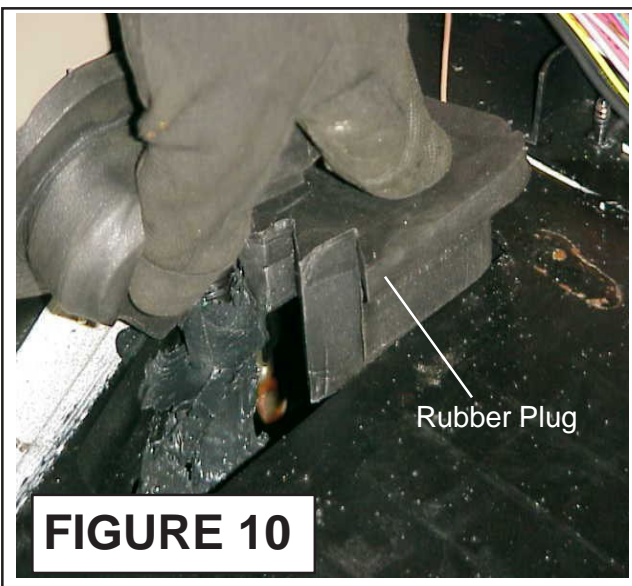
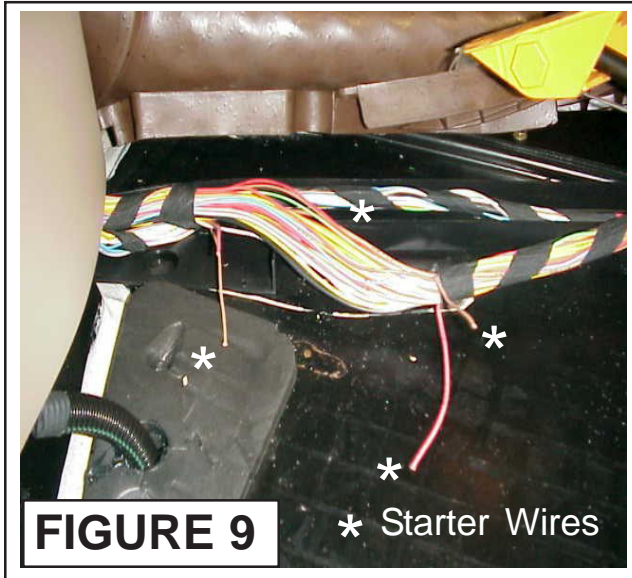
### Installing Wiring Harness for Joystick: (Continued)

4. **Wires to be Connected.** You will need to find the wire from the switch that activates the Starter Solenoid for the Tractor This wire will need to be cut to form 2 ends. You will need to locate the Ignition Switch Power Wire; this wire will have current only when Ignition Switch is on. This Wire will have a wire Tee'd into it. (See Figure 9)

5. **Wire Harness Through Cab.** There is a large rubber plug in floor; this is where the Joystick wiring harness will be put through the cab floor. This plug can be pulled up through the floor (See Figure 10). it will be required to cut a hole in this plug for the Wire harness to run through.

6. **Insert it Wire harness through Floor Plug** till the 4 wires that are not in the wire Harness are even with the Floor. The wires that are sticking out of harness will be run under Floor mat and under dash panel to switch or connected to the tractor harness. These wires are made long because of the different places they can be connected on various models.

7. **Connecting Harness Wires.** There are 4 wires that must be connected inside Tractor. 1. Red Wire (power supply), 1 Black Wire (Ground) and 2 Brown Wires (Neutral Safety Switch). These will have to be spliced into Tractor circuits. (See Figure 13).





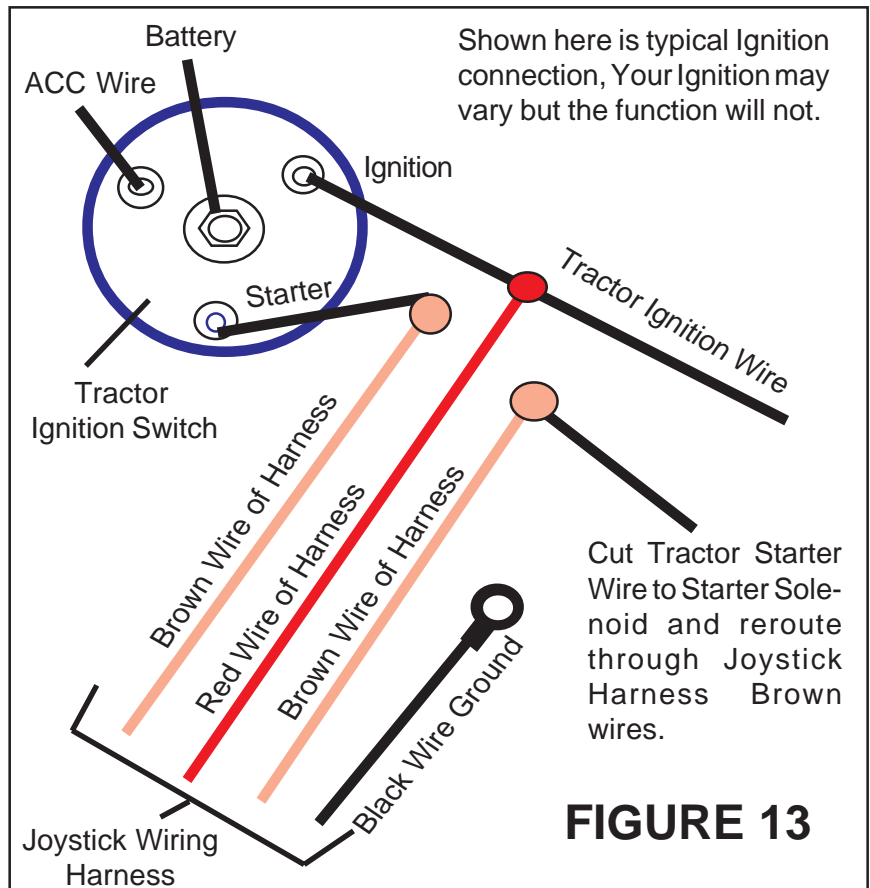
## Joystick Mounting 2 WD & 4 WD

### Installing Wiring Harness to Joystick:

(Continued)

8. Ground Wire. The Black wire at the harness (See Figure 11 and 13) can be connected inside the cab floor, or it can be run down through the floor and connected to the frame below the cab. If grounding to the Cab floor connect ground now.

9. Install Wiring Harness to Joystick. Pull the Wiring Harness up till it touches the bottom of the Joystick connection (See Figure 14). Align the Plug Guides (there are 1 wide and 2 narrow lugs) that prevent the plug from being installed wrong. Screw the plug retainer onto the Joystick Plug, this will be hand tightened.



**FIGURE 14**



**FIGURE 15**

10. Reinstall Floor Mat. DO NOT cut Floor Mat. Make sure you have remounted the wire harness protector over wire harness under floor mat (See figure 8). Push the wire harness over against the side panel (See Figure 15). Put the floor mat down as it was originally. When finished floor mat should be as smooth as it was before installation.

# Joystick Mounting 2 WD & 4 WD

## Installing Warning and Instruction Decals:

1. Always clean windows before installing decals. Windows must be dry and free of any oil, after cleaning do not touch windows before decals are installed. Take precaution to make sure decals are right side up and straight when installing them, they cannot be taken off and redone.

2. Identify Decals. Lay all the Decals out and ID each one so you will know which is installed where. The Decals will have the Part Number on them in the lower corners.

Decal No.	Description
00763977	Notice to Owner
02964677	Important - Boom Rest
02963524	Attention - Boom Swing
02965093	Proper Engine Operating
02965262	Warning - Hose Burst
02967827	Multi - Hazard

3. Multi-Hazard - Danger Decal. This is installed on the Left Side Window of Cab on the inside to Drivers Left. (See Figure 16)

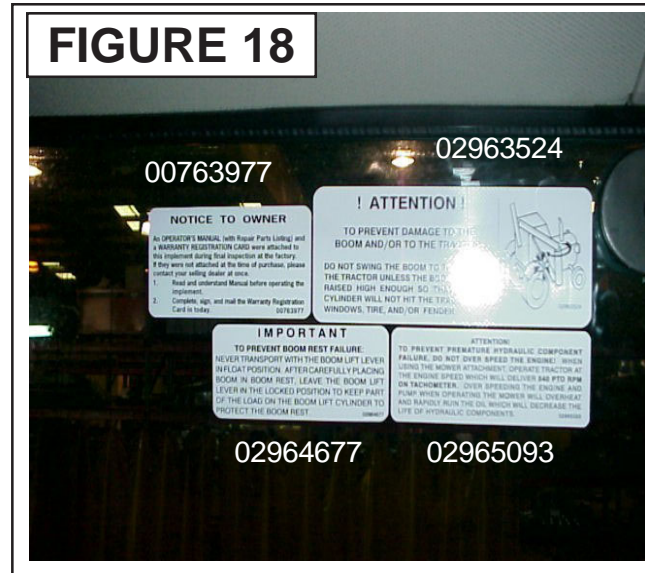
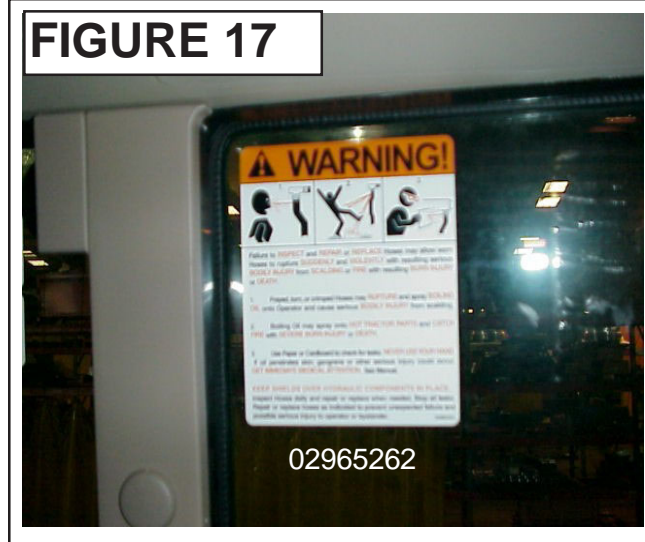
4. Warning Hose Burst Decal. This installs on the Right Side Window of Cab on the Inside to Drivers Right (See Figure 17)

5. Notice To Owner Decal. This installs on the inside top rear of Right Door Glass (See Figure 18)

6. Attention Boom Swing Decal. This installs on the inside top rear of Right Door Glass (See Figure 18)

7. Important Boom Rest Decal. This installs on the inside top rear of Right Door Glass (See Figure 18)

8. Proper Engine Operating Decal. This installs on the inside top rear of Right Door Glass (See Figure 18)



## Wire Harness / Valve Mounting 2 WD & 4 WD

### Installing Wire Harness To Valve:

#### 1. Wire Harness From Cab to Front.

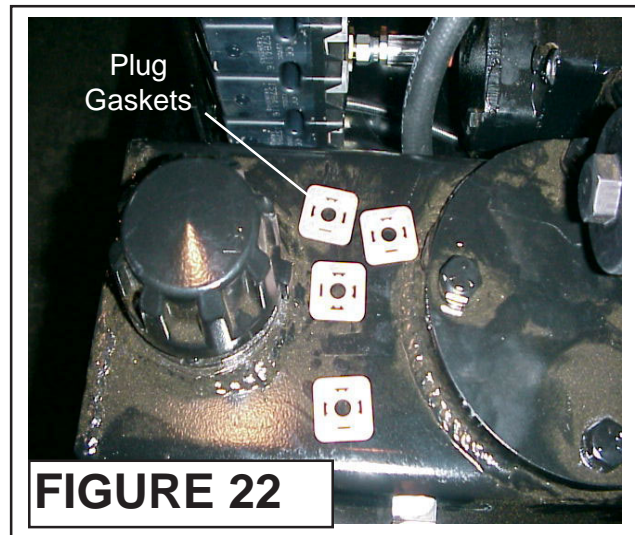
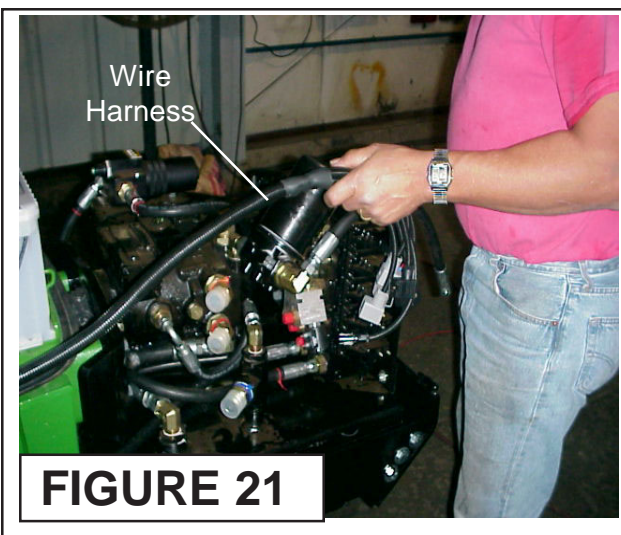
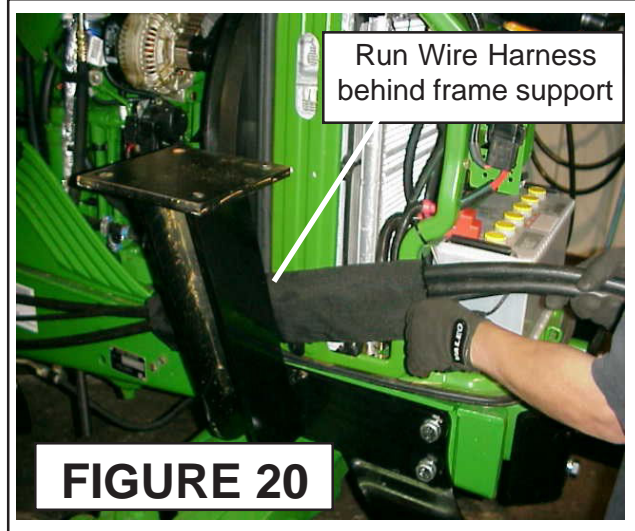
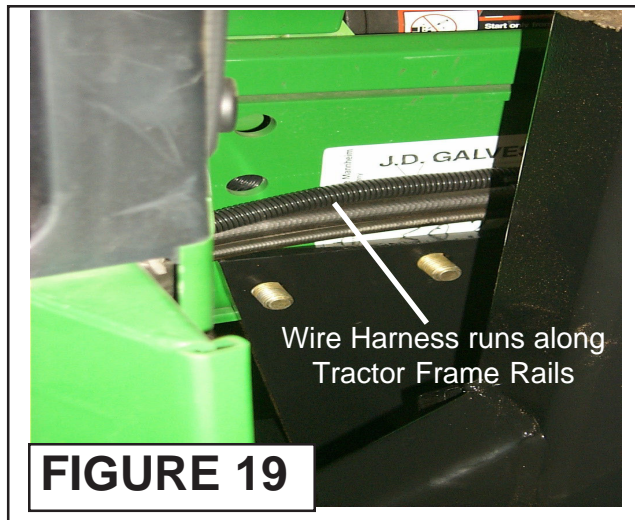
The wire harness runs out the bottom of the Cab on the right hand side. Run Harness along RH Frame rail of Tractor to the front of the Tractor (See Figure 19). Note the wire harness runs along with the hydraulic Hose from the Tractor Stack Valve to the front of the tractor. Do Not tie the Harness or Hoses to the Tractor frame rail at this time.

#### 2. Wire Harness & Front Rail Support.

The wire harness runs behind the front rail support on the RH side along side the hoses from the rear Tractor Stack valve. (See Figure 20). Do not tie any hoses or wire harness at this time. Run Wire Harness along the front RH side until it reaches the front of the Tank (See Figure 21)

#### 4. Gaskets on Valve Terminals.

There are 5 wire terminals on Valve, A Gasket will have to installed on each one. These gaskets will only fit one way, there are 4 slots in gasket. 1 Slot is wider than the other 3, align these slots with correct terminal on Valve. (See Figure 22 & 23). These Gaskets must be used.



# Wire Harness / Valve Mounting 2 WD & 4 WD

## Installing Wire Harness

### To Valve: (Continued)

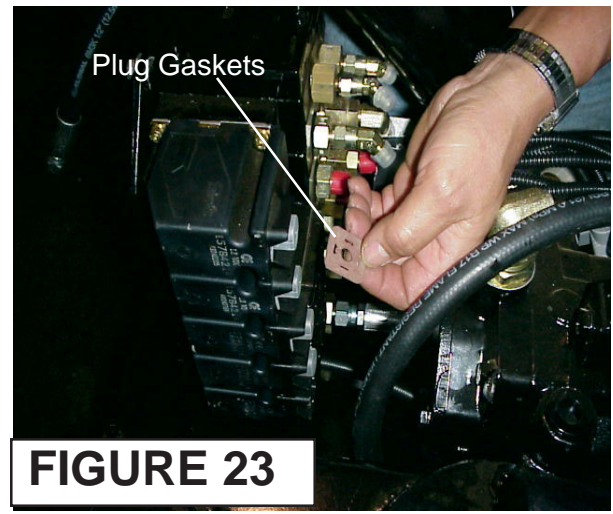
5. Wire Harness Terminal Identification. The Wire Harness Terminal Plugs are marked in writing on the plug. Swing, Lift, Dipper, Tilt and Door terminal plugs (5 Total). The Valve terminals are in this same order starting at the bottom and coming up on the valve. You will need to have a short handle Phillips screwdriver for this. (See Figure 26).

6. Wire Harness Terminal Installation. You will need to feed wire harness under the fitting across tank (See Figure 24) lay the Plugs out in the Order they are to be installed starting at the bottom terminal.

7. Terminal Connections. Make sure that each terminal Plug on Valve has had the Gasket installed on it, then Install Swing Terminal and tighten Plug Retaining Screw. Continue this with all 5 plugs starting at the bottom and coming up (See Figure 25)

PLUG	FUNCTION
1 Bottom Plug	Swing Terminal
2 2 nd Plug Up	Lift Terminal
3 3 rd Plug Up	Dipper Terminal
4 4 th Plug Up	Tilt Terminal
5 Top Plug	Door Terminal

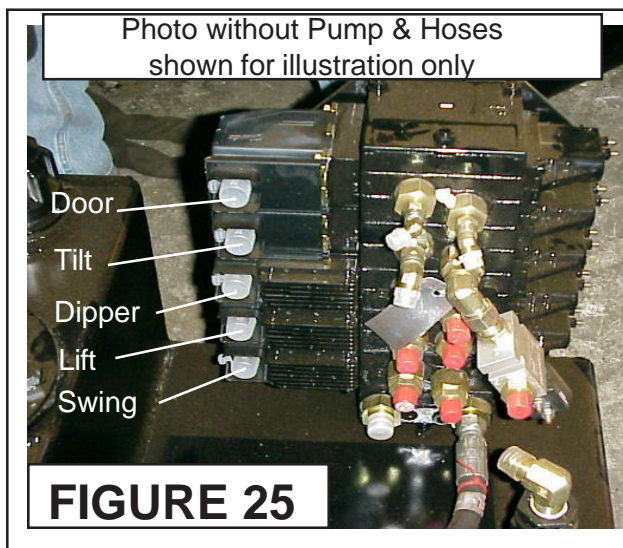
Connect and tighten all 5 terminal plugs one at a time till all 5 are connected. (See Figure 26)



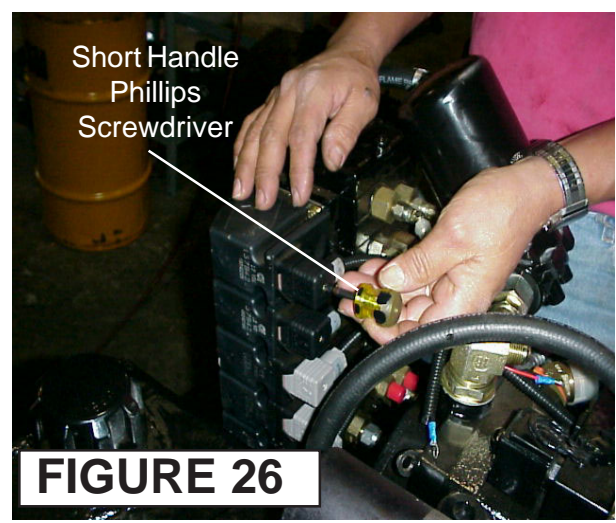
**FIGURE 23**



**FIGURE 24**



**FIGURE 25**



**FIGURE 26**

## Wire Harness / Valve Mounting 2 WD & 4 WD

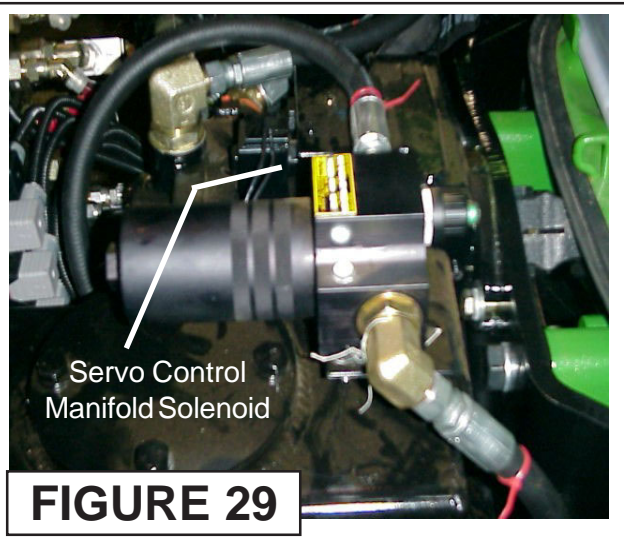
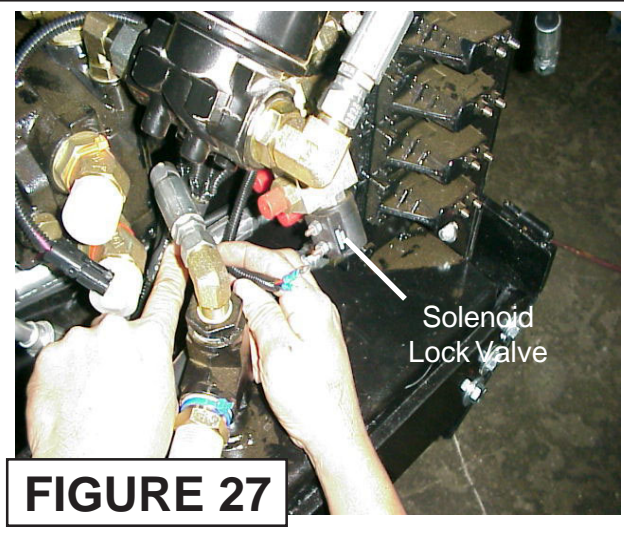
### Installing Wire Harness To Valve: (Continued)

8. Solenoid Lock Valve Connection. Solenoid Lock valve is mounted on the Valve Tilt Port on the RH Side (See Figure 27). Find the two wires in harness that has eye terminals on them. Connect them to the Solenoid Lock Valve (See Figure 27)

9. Servo Control Manifold Solenoid. Locate the last Plug in the harness. This Plug is a two wire self sealing push connector. the Control manifolds Solenoid is located on the top of the Pump and activates the Pump when engaged. (See Figure 28 and 29). **NOT USED ON A-BOOM, Disregard this Section**

10. Wire Harness Completed. Pull the Wire harness back toward Cab to remove any excess slack, only enough to remove slack not to make Wire Harness tight. Do Not tie wire harness or hoses to Tractor Frame Rails Yet. Tying Wire Harness and Hose up out of way will be done later. The Wiring Schematic is shown in this book as a reference only, the wire harness will come to you assembled and ready to mount. The only wires that will have to be altered are the wires inside that connect to the existing Tractor Wires. These inside wires are intentionally left long so they can be cut as needed. None of the wires with the factory plugs will have to be cut.

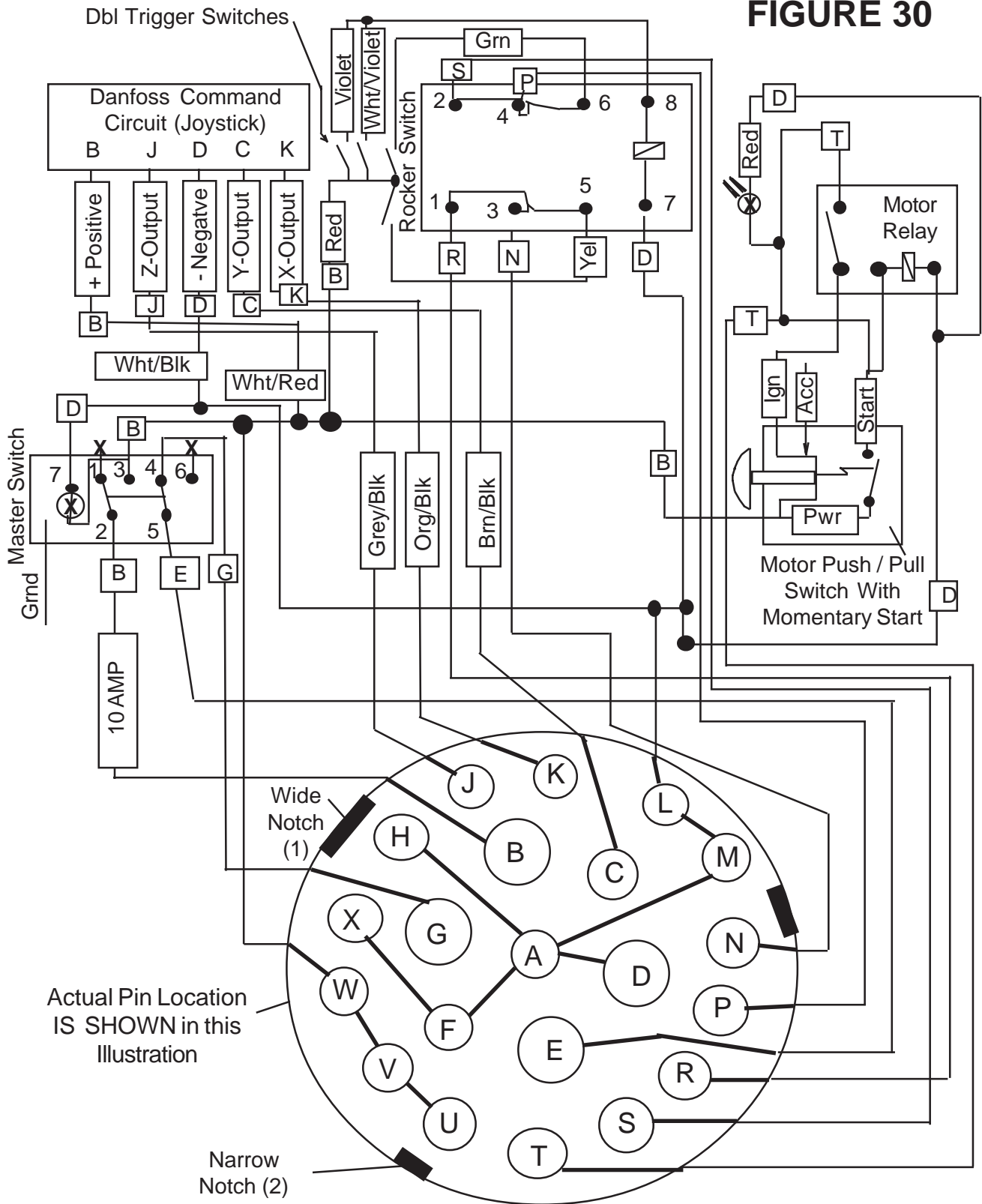
11. See the next two pages for Wiring Schematic, this is listed as reference only. Pin locations in schematic are actual pin locations in Plugs. Plugs are marked with the letters as shown. This schematic is listed to assist you in tracing wires through harness if needed. Do not change or modify the harness plugs in any way.



# Joystick Plug (Bottom of Joystick Console)

Joystick w/ Push/Pull Motor Switch & Rocker Master Switch

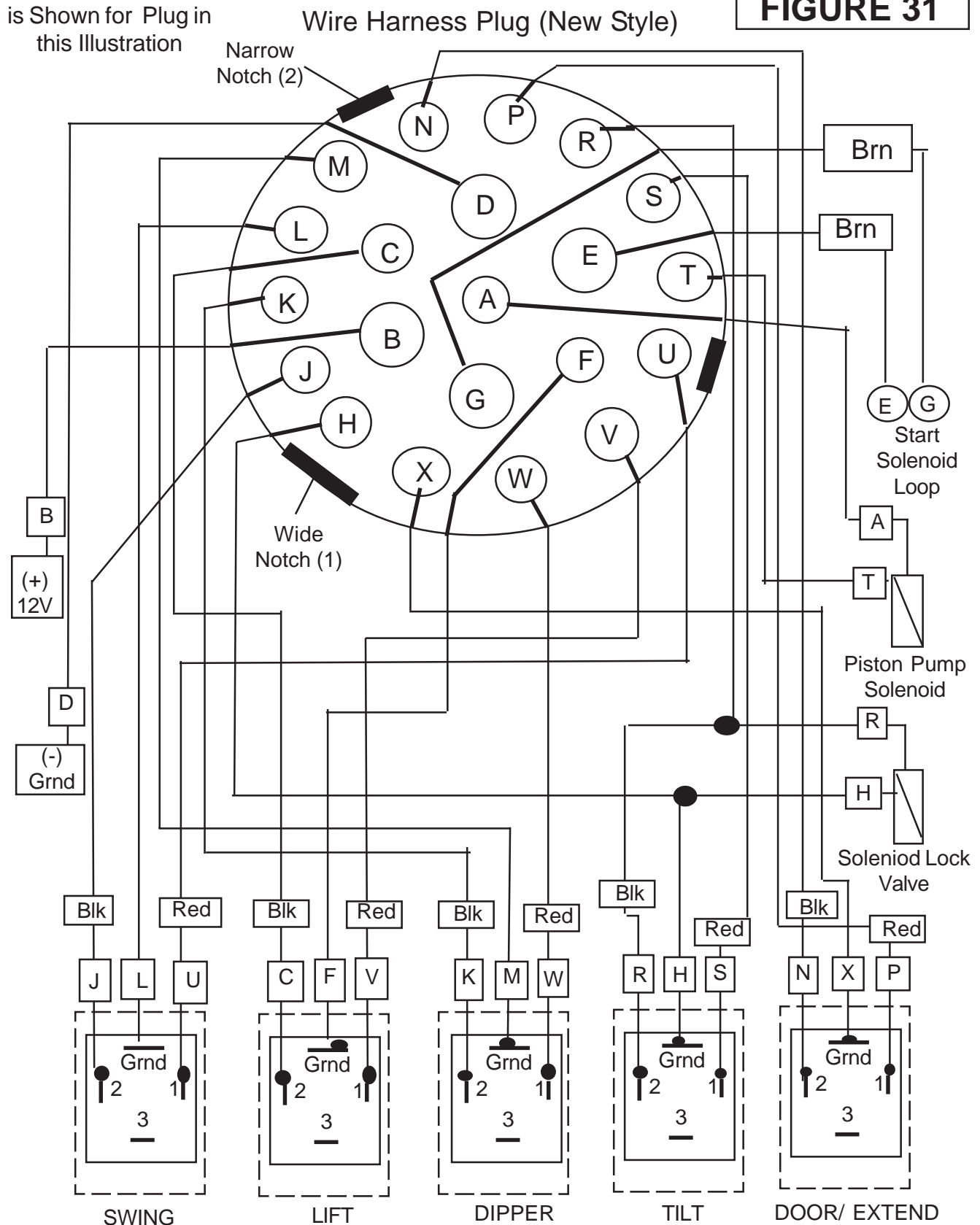
**FIGURE 30**



# Wire Harness (Joystick Console Plug to Valve)

Actual Pin Location is Shown for Plug in this Illustration

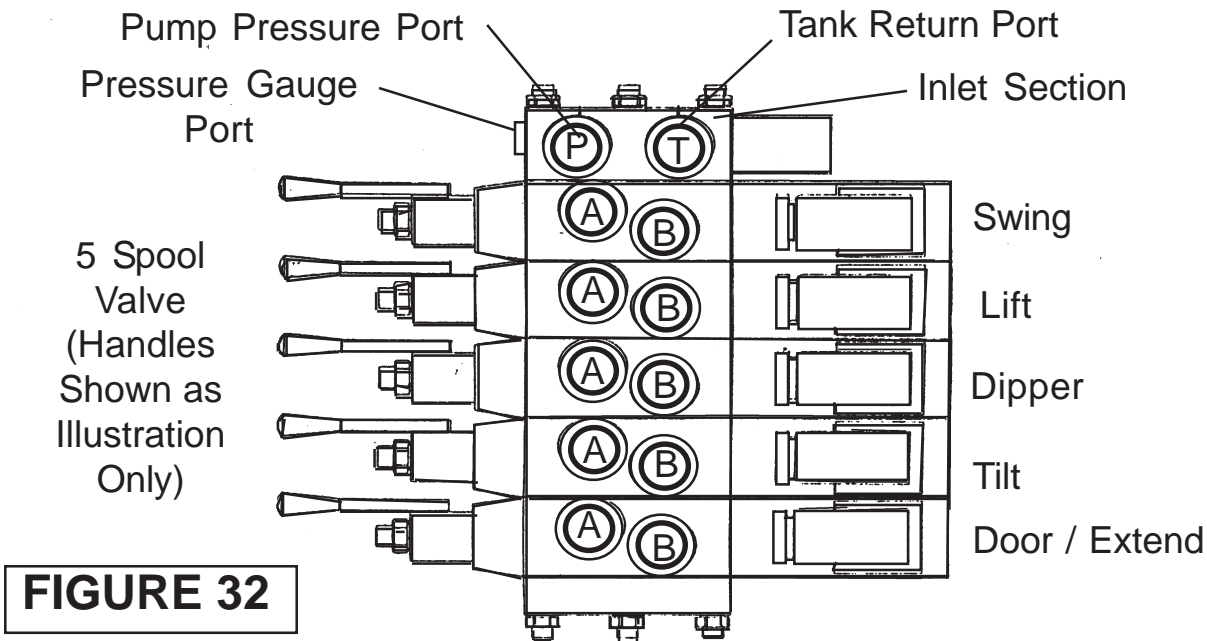
**FIGURE 31**



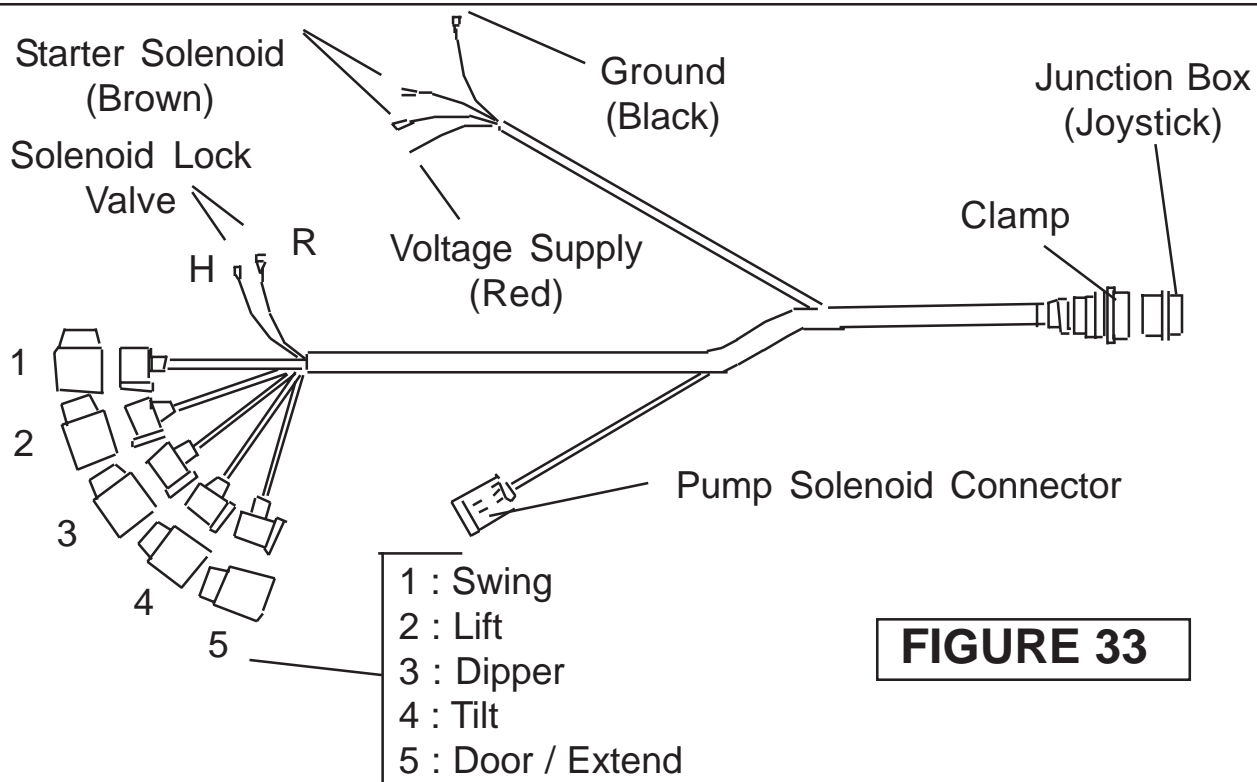
# Control Valve - Electric / Hydraulic

**CONTROL VALVES:** (See Figure 32)

The Alamo A-Boom Optional Hydraulic Control Valve is an Electro-Hydraulic (Electric over Hydraulic) Valve. The Valve is designed to utilize Oil from the Tractors Hydraulic System. This is basically considered a Selector Valve. The Hydraulic Control Valve must be compatible with the type Tractor System being utilized. There is only one type System used, The Fixed Displacement (Open Center) Continuous Flow. Hydraulic Supply is from front Aux. Pump



**FIGURE 32**



**FIGURE 33**



# NOTES

# Section 10

## **A-BOOM**

### **Head Installation (Optional Heads)**

# Optional Mower Head Installation

## Attaching Flail-Axe Head:

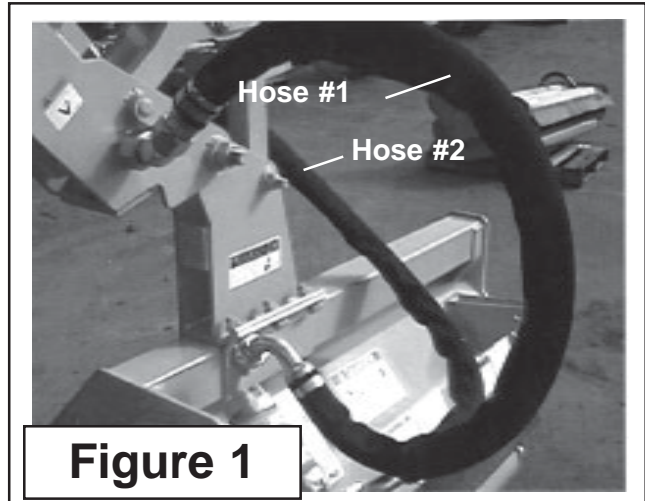
1. With a Forklift or Hoist, lower the boom Weldment on the Flail Axe Head. Align the boom Weldment with the Flail Axe Head Hitch Post. Insert special bolts (item 1 p/n 02956972 and item 2 p/n 00752405) into Boom Weldment and Hitch Post. Attach nuts (item 3 p/n 02030300 and item 4 p/n 00037200) to bolt and tighten securely. *Note: Additional support may be needed at the end of the Boom to aid in installation.*

2. Install Hoses p/n 02972573 (#1) and p/n 02972573 (#2) in positions shown. Fully extend and retract tilt cylinder and insure hoses do not bind or kink then secure fittings. Tighten any leaking Hydraulic Fittings. If fluid still leaks, loosen the fitting, apply a pipe thread compound to the end threads and tighten. Care must be taken when tightening can cause the fittings to crack and require replacement fittings. Use recommended hose end and torque values found in chart on page 22.

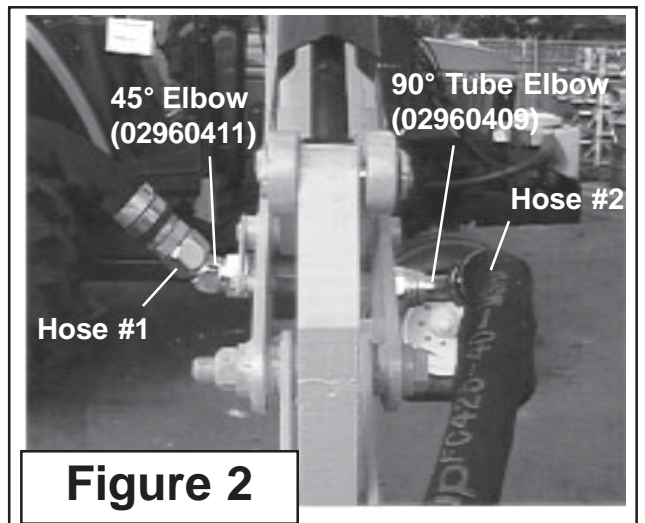
3. Warning, Escaping fluid under pressure can penetrate the skin causing serious injury. Relieve pressure before unhooking hydraulic or other lines. Tighten all connections before applying pressure. Keep hands and body away from pinholes and nozzles which eject fluids under high pressure. Use a piece of cardboard to search for leaks. If any fluid under pressure is injected into the skin, it must be surgically removed withing a few hours by a doctor familiar with this type injury or gangrene may result.

4. Hoses should not interfere with mower operation such as being pinched, kinked or entering the cutter housing. The hoses may be twisted slightly. To hold them up and/or inward tighten the fitting once the proper location is found.

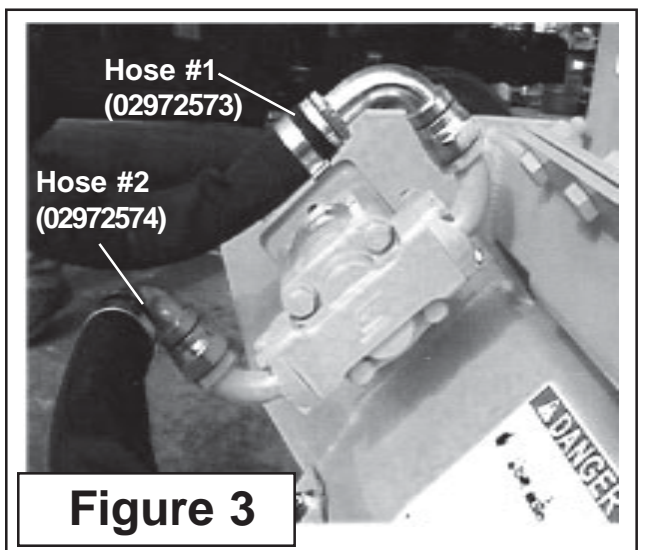
**\* Note the position of hoses and fittings. It is important that they are installed as shown.**



**Figure 1**



**Figure 2**



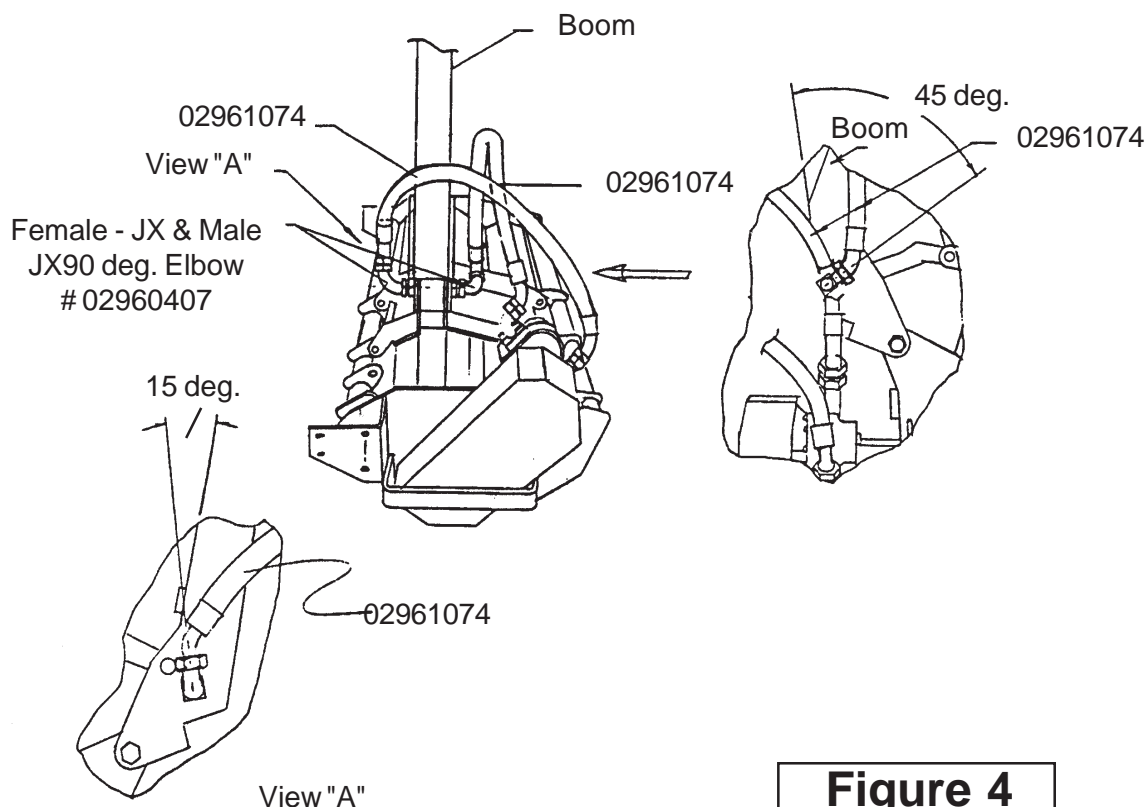
**Figure 3**

# Optional Mower Head Installation

## Attaching Flail Head:

1. With a Forklift or Hoist, lower the boom Weldment on the Flail Head. Align the boom Weldment with the Mower Head Hitch Post. Insert special bolts (item 1 p/n 02956972 and item 2 p/n 00752405) into Boom Weldment and Hitch Post. Attach nuts (item 3 p/n 02030300 and item 4 p/n 00037200) to bolt and tighten securely. *Note: Additional support may be needed at the end of the Boom to aid in installation.*
2. Install Hoses Female - JX in position as shown, hand tighten. **DO NOT** start Tractor until after filling Hyd Tank with Oil (See Filling Hyd Tank Section). Fully extend and retract tilt cylinder and insure hoses do not bind or kink then secure fittings. Tighten any leaking Hydraulic Fittings. If fluid still leaks, loosen the fitting, apply a pipe thread compound to the end threads and tighten (Do not allow Thread compound to get into Hydraulic system). Care must be taken when tightening, over tightening can cause the fittings to crack and require replacement fittings. Use recommended hose end and torque values found in chart in operators manual.
3. Warning, Escaping fluid under pressure can penetrate the skin causing serious injury. Relieve pressure before unhooking hydraulic or other lines. Tighten all connections before applying pressure. Keep hands and body away from pinholes and nozzles which eject fluids under high pressure. Use a piece of cardboard to search for leaks. If any fluid under pressure is injected into the skin, it must be surgically removed within a few hours by a doctor familiar with this type injury or gangrene may result.
4. Hoses should not interfere with mower operation such as being pinched, kinked or entering the cutter housing. The hoses may be twisted slightly. To hold them up and/or inward tighten the fitting once the proper location is found.

\* **Note the position of hoses and fittings. It is important that they are installed as shown.**

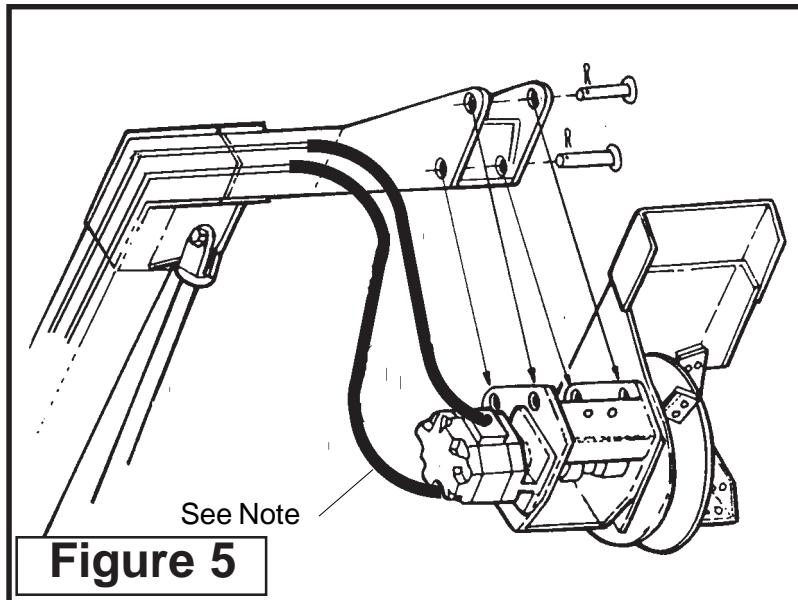


**Figure 4**

# Optional Mower Head Installation

## Attaching Ditcher Head:

1. With a forklift or hoist, lower the Boom Weldment down in the Ditcher Head. Align the Boom Weldment with the Ditcher Head Hitch Post together. Insert special pins p/n 02958929 into Boom Weldment and Hitch Post. Attach with washer P/N 00749185 and roll pin P/N 00610600. **NOTE:** *Additional support may be needed at the end of the Boom to aid in installation. (See Figure 5).*
2. Attach Hydraulic Hoses as illustrated (See Figure 69). Tighten all Hydraulic Fittings. Care must be taken when tightening Hydraulic Fittings. Over tightening can cause the fittings to crack and require replacement. Use recommended hose end torque values found in chart in operators manual..
3. The motor for the Ditcher will operate in both directions. It is important to plumb the motor so that it rotates to deposit the spoil properly. The direction of rotation can be observed by standing behind the Ditcher Head, beside the right rear tire. If the Ditcher rotates 'clockwise' it is plumbed for forward rotation and the spoil will be deposited away from the tractor. If the Ditcher is the reverse design then the proper rotation is counter-clockwise when observed from the rear. Do Not try to reverse Ditcher from Rotation it was designed for, it will not work. The Forward and reverse Rotation Models do not use the same Blade Assembly.
4. **Note:** The two hoses (P/N 02961054) connecting the main boom to dipper arm are used to connect the Ditcher motor. The 90 degree fittings attach to the fittings on the main boom and the straight fittings attach to the 90 degree fittings on the hydraulic motor. See Figure 69 below.



**WARNING** Escaping fluid under pressure can penetrate the skin causing serious injury. Relieve pressure before unhooking hydraulic or other lines. Tighten all connections before applying pressure. Keep hands and body away from pinholes and nozzles which eject fluids under high pressure. Use a piece of cardboard to search for leaks. If ANY fluid under pressure is injected into the skin, it must be surgically removed within a few hours by a doctor familiar with this type injury or gangrene may result.

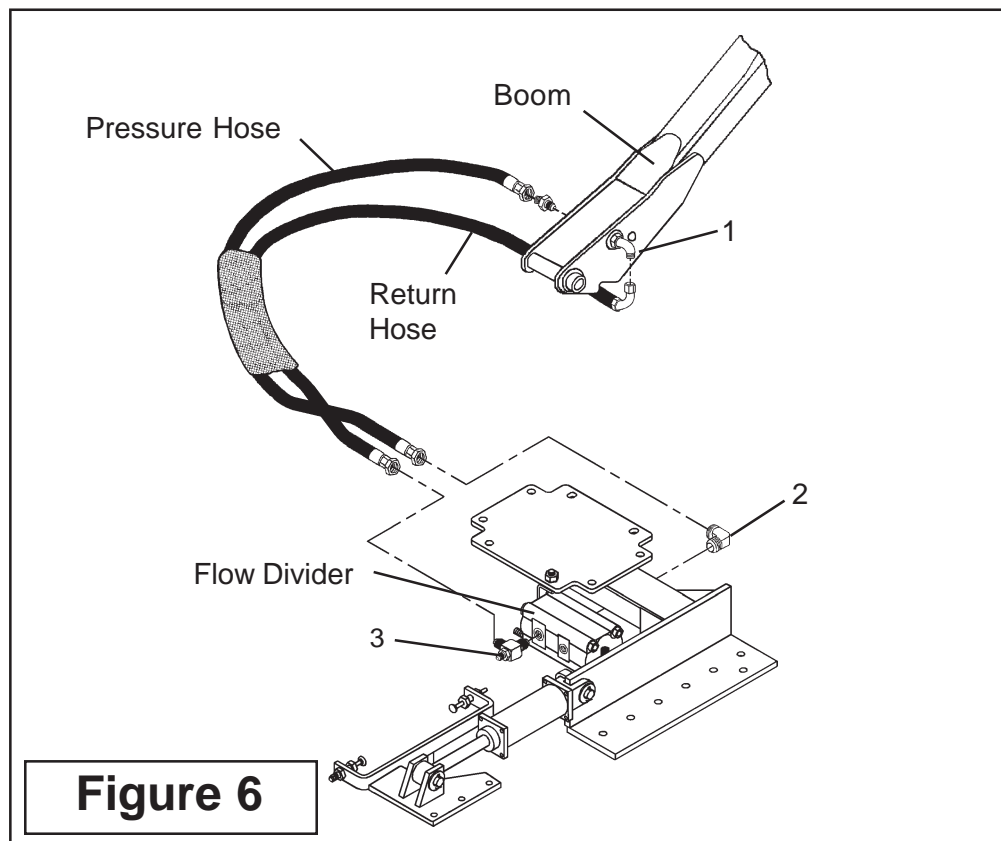
# Optional Mower Head Installation

## Attaching Timber Cat Head:

1. Attach the Timber Cat Head to the boom using the pins included with the head. Be careful not to damage the pivot bushings in the boom when inserting the pins. Attach the 90° elbow (Item 1) to the front port of the boom and position it so that it faces down. Attach the 90° end of the return hose (P/N 02973125) to the fitting and attach the straight end to the 90° fitting (Item 2) on the flow divider (if it is not already connected). Attach the pressure hose (P/N 02973124) to the rear port of the boom and attach the other end to the 90° elbow (Item 3) on the flow divider (if it is not already attached). (See Figure 6.)

2. Be sure the hoses are routed as shown in the figure and securely tighten all connections. Stop here and go to Hydraulic Oil Tank fill setion, DO NOT Start Tractor until Hydraulic tank has been filled. Start tractor and move the head tilt through its motions and check for excessive twisting and bending. It may require many attempts to obtain the optimum hose connection position. Once achieved, start the tractor and position the head in a safe area for operation, if necessary, baracade the head to prevent any contact while it is being operated. **This unit is dangerous - STAY AWAY - anytime the tractor is in operation!** Turn on the head and bring the tractor engine up to normal operating speed (540 PTO RPM). Tighten any leaking hydraulic fittings. Caution, too much tightening can cause the fittings to crack and require replacement. Use recommended hose end torque valves found in the Maintenance Section.

**WARNING** Escaping fluid under pressure can penetrate the skin causing serious injury. Relieve pressure before unhooking hydraulic or other lines. Tighten all connections before applying pressure. Keep hands and body away from pinholes and nozzles which eject fluids under high pressure. Use a piece of cardboard to search for leaks. If ANY fluid under pressure is injected into the skin, it must be surgically removed within a few hours by a doctor familiar with this type injury or gangrene may result.



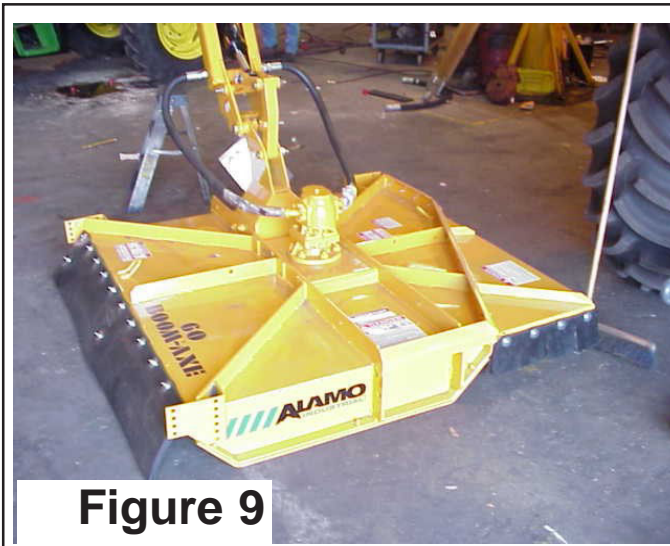
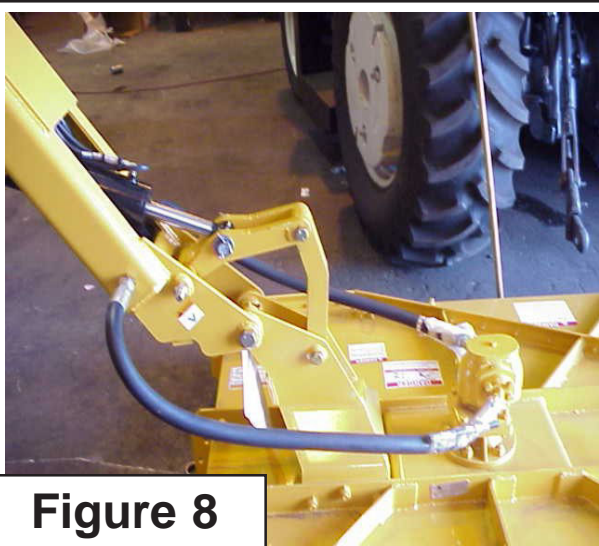
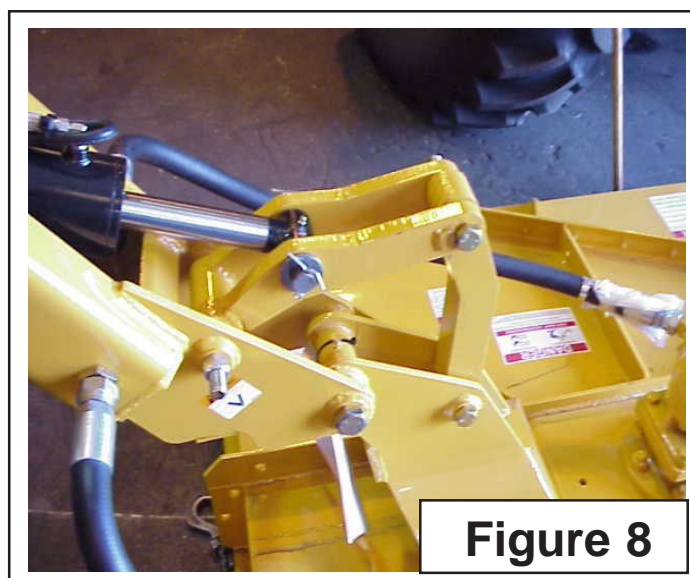
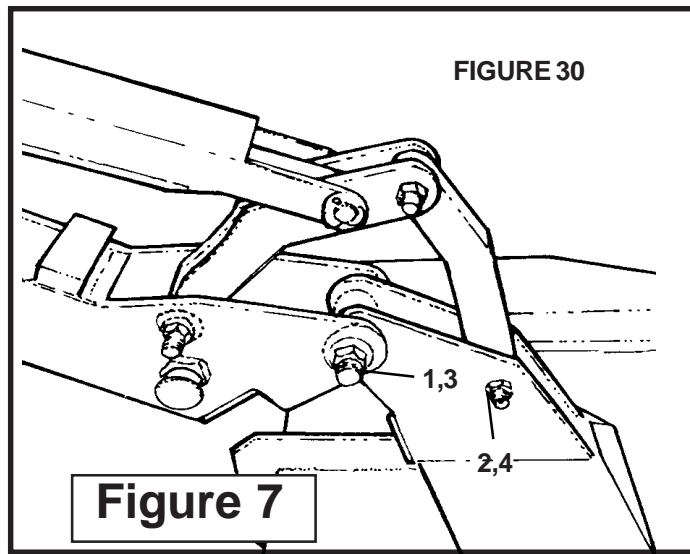
## Optional Mower Head Installation

### X-Frame Square Head Attachment:

1. With a forklift or hoist, lower the Boom Weldment down on the X-Frame Square Head. Align the Boom Weldment with the X-Frame Square Head Hitch Post. Insert special bolts 1" x 9" (item 1) and item 2, 3/4" x 5-1/2" into Boom Weldment and Hitch Post. Attach nuts 1" (item 3) and item 4, 3/4" to bolt and tighten securely. **Note:** Additional support may be needed at the end of the Boom to aid in installation. **Figure 7.**

2. Connect the Pivot Hitch to Mower as shown in Parts and Assembly Manuals. (See Figure 8)

3. Connect Hoses to Mower Head. Connect Hoses as shown (See Figure 8 & 9) Boom to Mowers, Do Not Start tractor until the hydraulic Tank has been filled, Go to Hydraulic Tank Fill Section now. After Oil has been fill Start Tractor and run the Hydraulic System through its functions as outlined in the Oil Fill Section. NEVER Start Tractor without Oil in system (Oil level to Sight Glass) it will damage the Hydraulic System if you do.



# Section 11

## **A-BOOM** **Fill Hydraulic Tank**



# Fill Hydraulic Tank

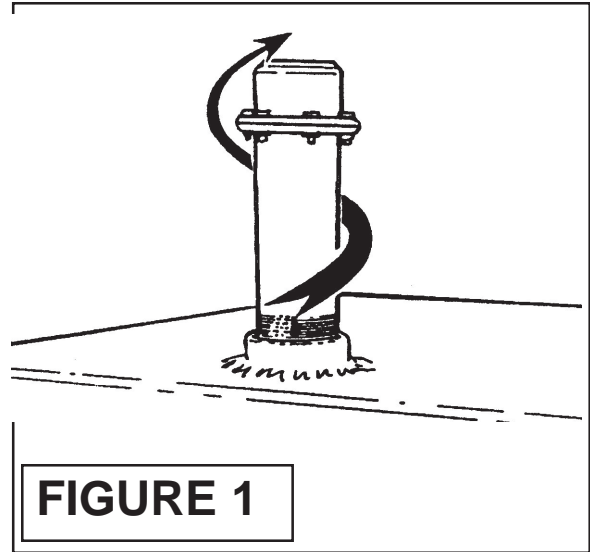
## Fill Hydraulic Tank with Oil:

1. **DO NOT START TRACTOR** until you have filled Hydraulic Oil Tank to a level as shown in Sight Glass gauge and fill the Suction Hose to Pump with Oil.

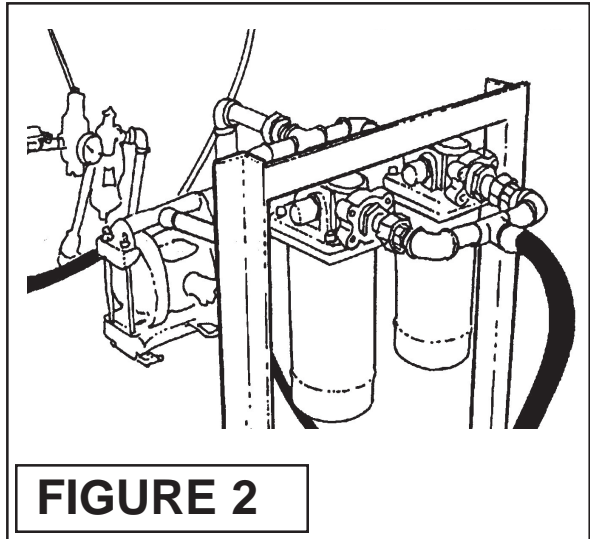
2. **Remove Filler Cap.** Remove Filler cap only when ready to fill hydraulic Tank with Oil. Do Not leave the Cap off and the system Open, always keep sytem closed when possible. Avoid any oil contamiantion. (See Figure 1)

3. **Avoid Hydraulic Contamination** by filtering the Hydraulic Oil while filling the Hydraulic Tank. Filter buggies or carts are commercially available for Hy-draulic system clean-up and Oil transfer. These consist of high capacity filter, a Circulating Pump, a Drive Motor and hoses for connecting to the units hydraulic system. When adding Oil always use Clean new Oil from a sealed container, If you suspect the Oil of being contaminated don't use it. (See Figure 2 & 3). It is best to always use a filter system when adding even new oil.

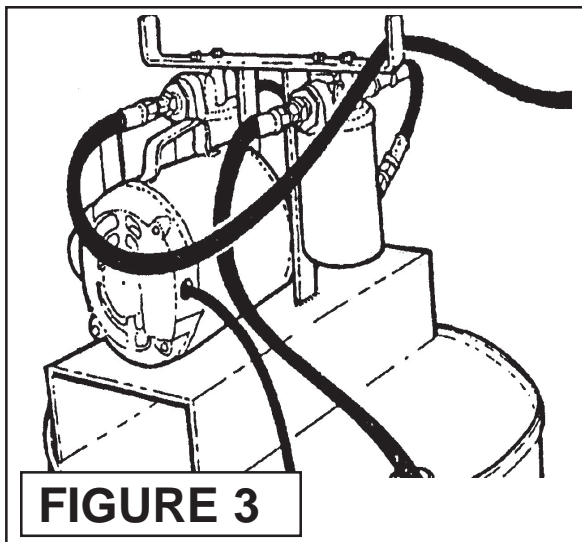
4. **When adding Oil in the field** keeping it clean is critical, do not use dirtng funnels or hoses. Do Not open Hydraulic tank or any contaners unless the openings have been cleaned first. The outside of the containers must be clean. If a windy dusty day do not fill and allow dirt to blow into oil. Always add Oil using a pump systemwith at least a 10 Micron filter system. (See Figure 4)



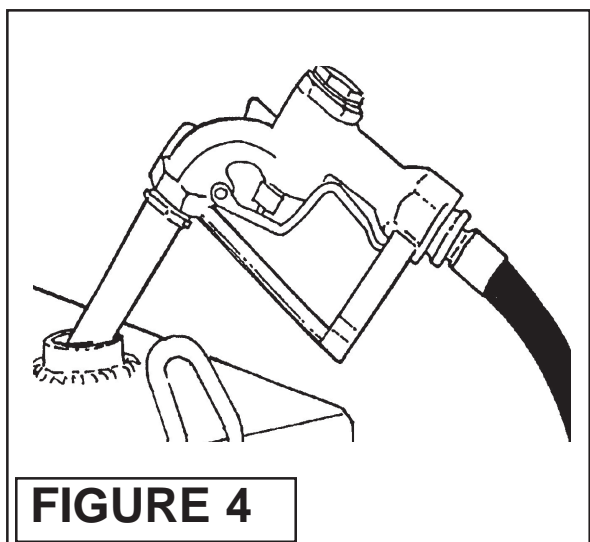
**FIGURE 1**



**FIGURE 2**



**FIGURE 3**



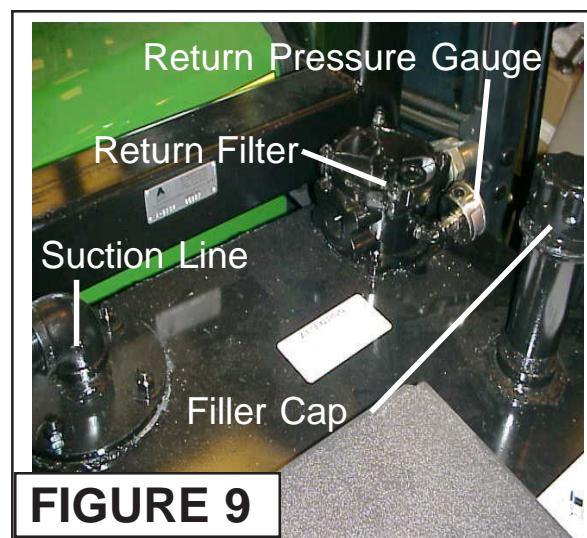
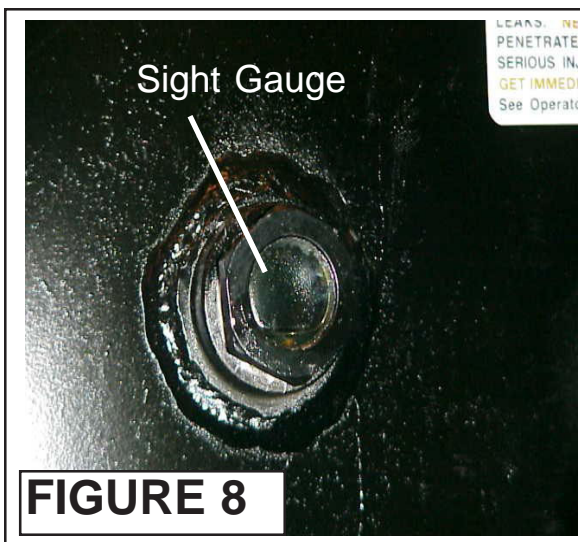
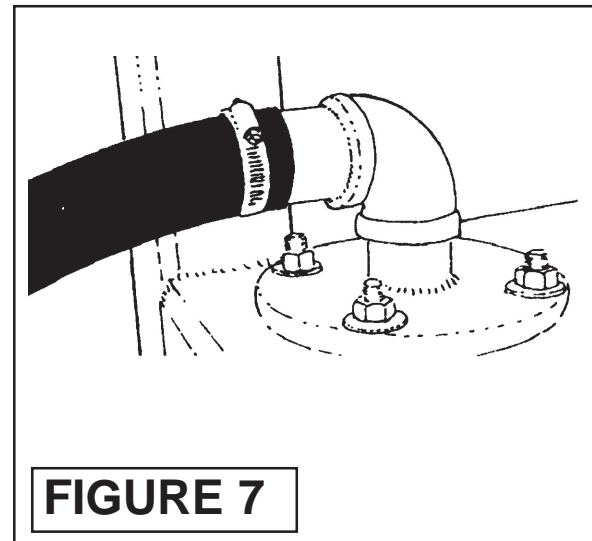
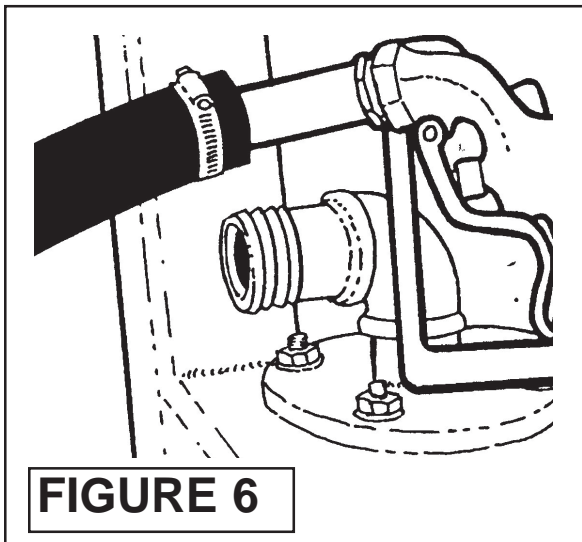
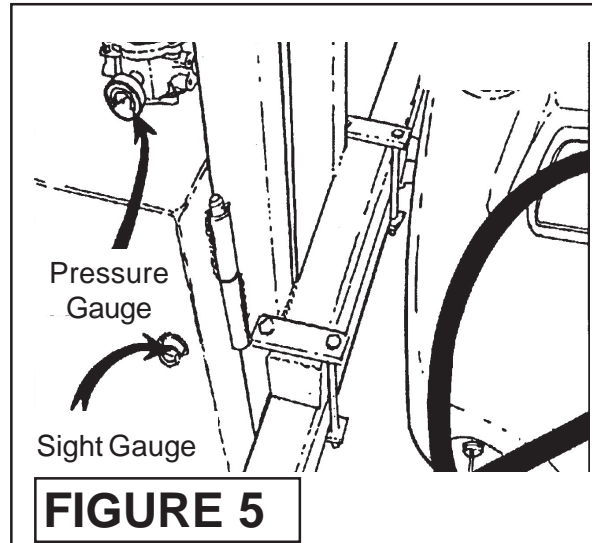
**FIGURE 4**

# Fill Hydraulic Tank

## Fill Hydraulic Tank with Oil:

5. **Fill Tank.** Fill the Hydraulic Tank (See Figure 4) Fill tank till the Oil is visible in the sight Gauge (See Figure 5 & 8). This will fill tank for the start but it will have to filled again later.

6. **Fill Suction Hose with Oil.** Remove the Suction Hose at the Tank (See Figure 6) and fill the hose with clean oil, THIS IS A MUST DO. The Suction Hose must be filled with Oil to prevent Dry strat up of Pump. Dry start up of PUMP will damage the Pump. After filling suction Hose reinstall it and tighten down Hose Clamp. (See Figure 7)



# NOTES

# Section 12

## **A-BOOM**

### **Hydraulic Start-Up Procedures**

## Start-up Instructions:

1. Read all safety instructions. Decals on the A-Boom warn you of particular and multiple Hazards. Many decals are attached close to part of the A-Boom where there is a possible hazard. Read and make sure you understand the safety messages before you operate the A-Boom. Keep all decals clean and readable. Replace lost or damaged decals.
2. Before operating, read all the safety and operating instructions in the Operator's Manuals for both the tractor and mower.
3. When the hydraulic tank has been filled, The Pump Suction Hose filled with Hydraulic Oil and the mower unit (Head) properly assembled, the unit should be started up. NOTE: Make sure that no materials, tools, or jacks have been left under the mower head. Make sure the front and rear of the mower are properly guarded to prevent any foreign objects from being thrown by the mower. All other workers should be kept a safe distance from the unit before the mower is started.
4. Start the tractor and idle at a slow engine speed until oil is being pumped. Check for any leaks, this is easiest with an assistant watching for leaks. Do not run if Oil is leaking.
5. Bleed the air out of all hydraulic cylinders one at a time by extending them to their full length. DO NOT SWING THE BOOM till last and you have gone to the Rest Stop and Support Section for instructions.
6. Engage the Cutter Control Valve at low engine rpm and run the mower slowly for a short period until all air is removed from the hoses. Keep all persons WELL CLEAR of mower since Blades can THROW OBJECTS with great velocity for a considerable distance! KEEP CLEAR!
7. Run the mower at a low tractor engine speed until the mower Hydraulic System gets the Air out of it. Operate at an engine speed that keeps the filter restriction gauge reading in the "Green Zone". With the hydraulic warm, bring the tractor speed up to normal operating speed. If the filter gauge reads in the red zone, stop the unit, release all hydraulic oil pressure, and Check the filter element in the tank mounted filter or any Hose that may be kinked. Restart the tractor and mower unit and again check the filter gauge (oil must still be hot).
8. If the filter gauge reads in the red when first started and does not drop as oil warms, then something is wrong, contaminants have been introduced into the hydraulic system or something connected wrong. You may need to repeat previous steps again until the gauge reads in the green.
9. Check the fluid level in the Hydraulic Tank and add oil if required. As the air has been forced out of the Cylinders and Hoses, it goes into the Hydraulic Tank and reduces the oil level. The Hydraulic Oil must be at least at the level of the Sight Gauge on the side of the Tank.
10. Basic trouble shooting guide for first start up.
  - A. Electrical solenoid valve does not work - check wiring, possible faulty switch, possible faulty solenoid.
  - B. Pump is making noise - check for obstruction in suction hose and tank suction assembly, check alignment of pump driveshaft.
  - C. Cylinders will not raise - hoses from cylinder incorrectly connected to valve bank, pump not supplying oil.
  - D. Cylinder rises slowly - hoses from cylinder incorrectly connected to valve bank, work port reliefs on valve bank set too low - replace as required.
  - E. Filter reads in red - viscosity of oil too high - wait until oil heats up before checking filter gauge. If gauge reads in red even after unit is hot, then the filter must be replaced.

## Post-Assembly Check List:

1.  Is oil level in the tank even with the sight gauge on the tank?
2.  Has the proper oil been used in the system? Proper oil is Universal Tractor Hydraulic.
3.  Does Boom machine movement match operation decal - Swing, Lift, Dipper, Tilt?
4.  Is control valve free and does it not stick?
5.  Are all hoses tight and do not leak?
6.  Are all decals in place? See Safety Section in Manual for decal description and placement.
7.  Does tractor pass Alamo Group Mower Stability Test?
8.  Have all grease points been adequately greased?
9.  Are all bolts tight?
10.  Have all hoses been properly routed so that hoses do not kink or bend when boom is articulated through all motions?
11.  Does starter lockout device work correctly on machine? Tractor should not start if mower switch is on.
12.  Is swing cylinder pinned in correct hole? On rear-swing type machine cylinder should be pinned to outside hole. On front-swing type machine cylinder should be pinned in inside hole.
13.  Is machine equipped with proper operator protection? Must have cage or cage panels.
14.  Does mower operate when on/off switch is on? Stop when switch is off?
15.  Is head rotation correct? On rotary heads (looking from the top of the deck) rotation should be clockwise so that debris will be thrown away from the tractor. On flails, rotation can be forward or reverse, but forward rotation is standard.
16.  If furnishing a square head, are spindle housing bolts tight? Is spindle assembly tight? Are bolts that hold blade bar to spindle tight?
17.  Does head operate smoothly at normal operating speed? Head should not vibrate excessively.

# NOTES

# Section 13

## **A-BOOM**

### **Boom Rest Plate and Boom Swing Stop Installation**



# Boom Rest Plate & Hook Installation

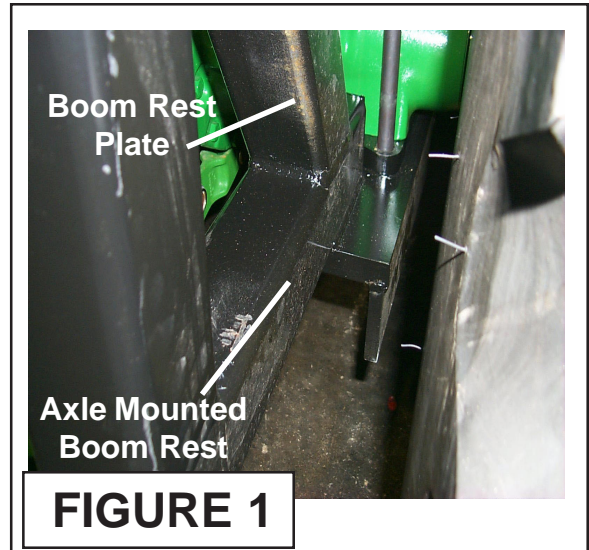
## Boom Rest Plate installation:

1. **Boom rest Mounted.** Boom rest should already be mounted and tighten down to Tractor from earlier assembly section. At the top of the Boom rest there will be a Boom rest Plate bolted to Boom rest, this should be mounted out to the Far right side.. (See Figure 1)

2. **Boom Rest Weld on Transport Plate.** There is a Boom Rest Hook plate tied to the Top Boom Hoses for shipment and cannot be mounted till the Assembly of this Unit is finished. Remove this plate now. it is tied to Boom hoses with th 2 plastic ties. (Do Not Weld on yet, wait till instructed to do so). (See Figure 2).

3. **Swinging Boom.** Extreme caution must be used when swinging Boom, There is NO BOOM STOP INSTALLED and can not be installed till later. Slowly swing boom Up and back watching the Cab so as not to hit it with the Boom. Do nor raise Boom higher than the inner stop om Boom rest plate bolted to the top of the Boom rest. Swing Boom till it is aligned in Boom Rest. The Head should be in the folded position as you lower Boom (See Figure 3).

4. **Slowly lower the Boom** down into Boom Rest. You will need to take measurement on the Boom (See Figure 4) here and Mark the Boom so you can weld on the stop plate to Boom. The Height of the Boom when in the Boom Rest should not exceed 12 ft. 9 in. max. (See Figure 4).

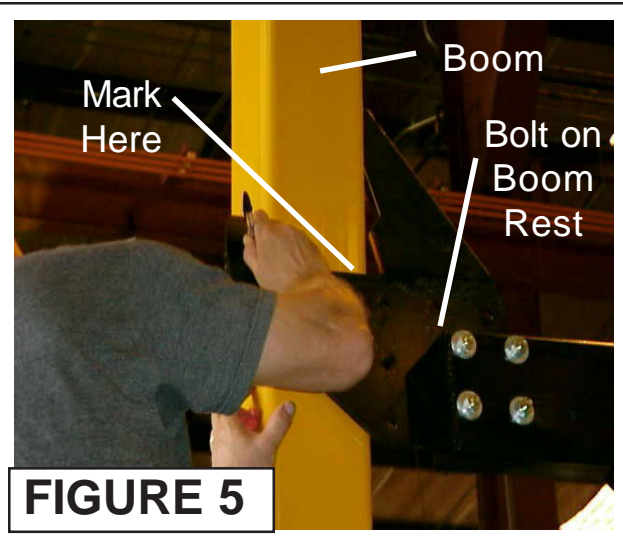


# Boom Rest Plate & Hook Installation

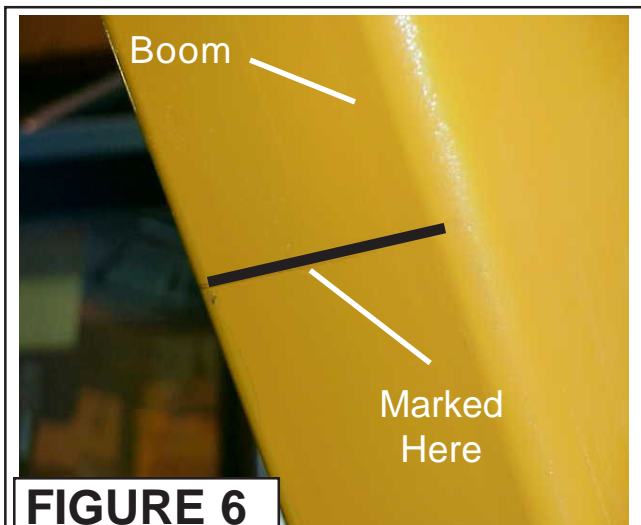
## Boom Rest Plate installation:

5. **Marking Boom.** Use a Black (or color desired) to mark the Boom, Make a Line on the Boom parallel with the Bolt on Boom Rest across the Boom, (See Figure 5 & 6). This line will be used to align the the Boom Plate Rest Hook for welding to Boom.

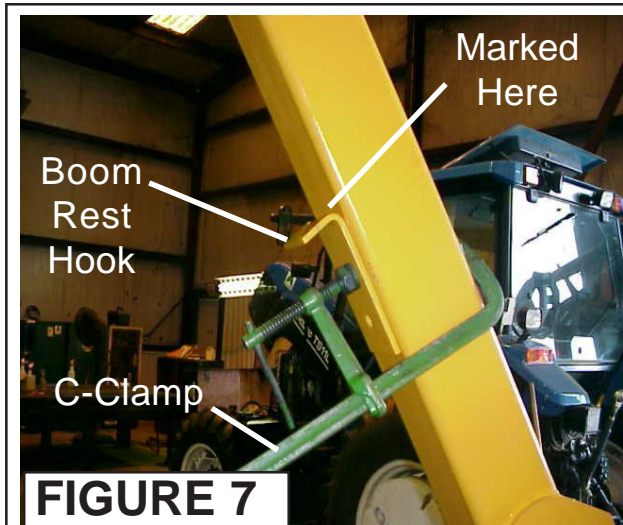
6. **Clamp Boom Rest Hook to Boom.** Align Boom Rest Hook with the line on Boom and clamp with large C-Clamp (See Figure 7). Remove Paint if possible (See Figure 8). Weld both sides of the Boom Rest Hook to Boom (See Figure 9) Move Boom back into Boom rest and check for fit.



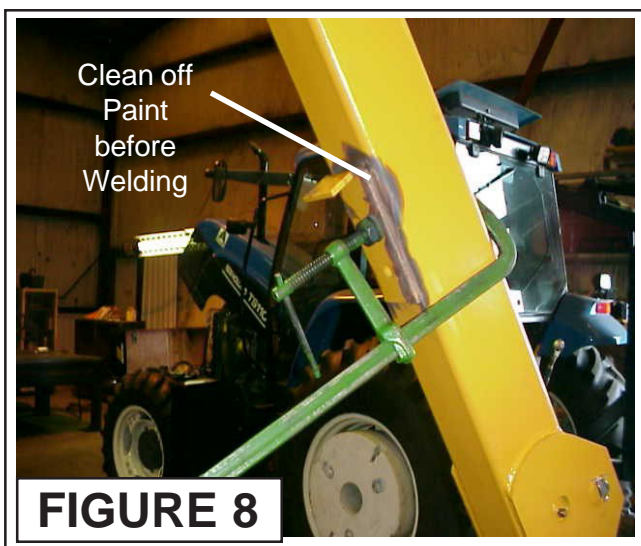
**FIGURE 5**



**FIGURE 6**



**FIGURE 7**



**FIGURE 8**



**FIGURE 9**

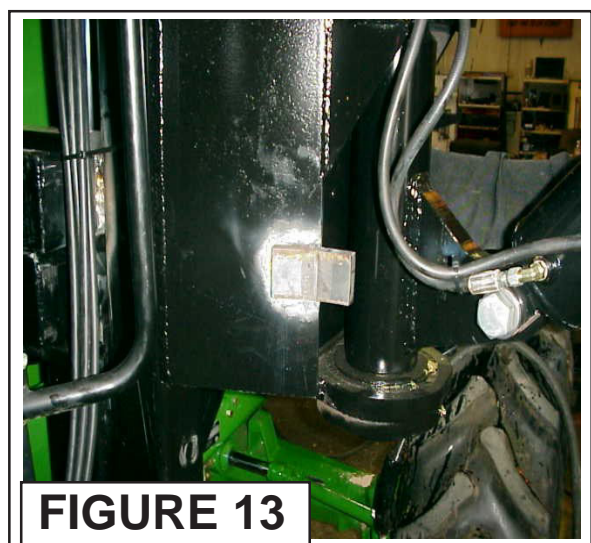
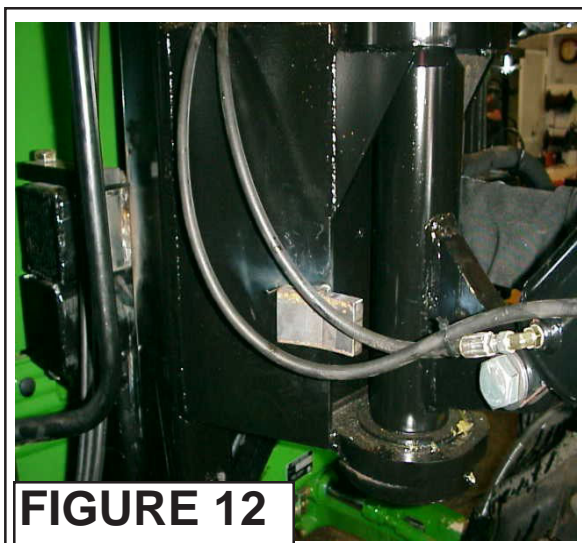
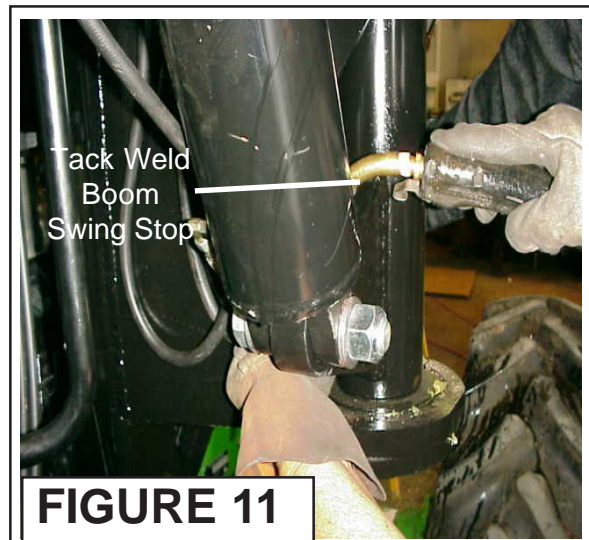
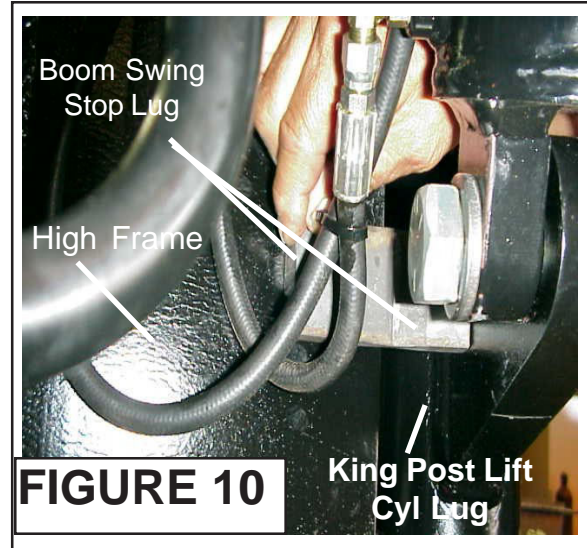
# Boom Swing Stop Installation

## Boom Swing Stop installation:

1. **Position Boom Swing Stop Lug.** Boom Swing Stop Lug is used to prevent Boom from swinging back to far and hitting Cab. With Boom folded and rest in on Boom Hook in Boom Rest Plate. Position the Boom Swing Stop on King Post Mount behind the Lift Cylinder Lug. (See Figure 10) This can be difficult to hold here while you tack it, it is important that it be square and touch the Cylinder lug as shown. (See Figure 10).

2. **Tack Weld Boom Swing Stop Lug.** Tack Weld the Boom Swing Stop Lug to the King Post Mount (DO NOT Weld to the King Post). (See Figure 11) Tack Weld the Lug secure enough that the Boom can be swung out to the side, this gives you more room to weld on the Boom Swing Stop Lug completely (See Figure 12)

3. **Weld Boom Swing Stop Lug Solid.** After the Boom is swung out 90 deg. from tractor completely weld the Stop Lug to the King Post Mount on High frame (See Figure 12). Slowly swing the Boom inward to the Boom rest and make sure the Boom cannot be swung in so far that it will hit the cab of tractor. This is a very critical step and must be done with extreme caution so as not to damage Cab of tractor.



# NOTES

# NOTES





**A-Boom  
(JD 6615 & JD7615)  
Assembly Manual  
2003 Edition  
P/N 02980169**

---

A-Boom (JD 6615 Asy Instruction Manual) 05/03

© 2003 Alamo Group Inc.