

# WSM

---

WORKSHOP MANUAL  
**TRACTOR, MOWER,  
FRONT LOADER**

**BX1870, BX2370, BX2670,  
RCK48-18BX, RCK54-23BX,  
RCK60B-23BX,  
RCK48P-18BX, RCK54P-23BX,  
RCK54D-26BX, RCK60D-26BX,  
LA203A, LA243A**

---

**Kubota**

# TO THE READER

This Workshop Manual tells the servicing personnel about the mechanism, servicing and maintenance of KUBOTA Tractor BX1870D, BX2370D, BX2670D, KUBOTA Rotary Mower RCK48-18BX, RCK54-23BX, RCK60B-23BX, RCK48P-18BX, RCK54P-23BX, RCK60D-26BX, RCK54D-26BX and KUBOTA Front Loader LA203A, LA243A. It contains 4 parts: "**Information**", "**General**", "**Mechanism**" and "**Servicing**".

## ■ Information

This section primarily contains information below.

- Safety First
- Safety Decal
- Specifications
- Dimensions

## ■ General

This section primarily contains information below.

- Engine Identification
- Model Identification
- General Precautions
- Maintenance Check List
- Check and Maintenance
- Special Tools

## ■ Mechanism

This section contains information on the structure and the function of the unit. Before you continue with the subsequent sections, make sure that you read this section.

Refer to the latest version of Workshop Manual (Code No. 9Y021-01870 / 9Y021-18200) for the diesel engine / tractor mechanism that this workshop manual does not include.

## ■ Servicing

This section primarily contains information below.

- Troubleshooting
- Servicing Specifications
- Tightening Torques
- Checking, Disassembling and Servicing

All illustrations, photographs and specifications contained in this manual are of the newest information available at the time of publication.

KUBOTA reserves the right to change all information at any time without notice.

Since this manual includes many models, information or illustrations and photographs can show more than one model.

December, 2012

© KUBOTA Corporation 2012

## **Record of Revisions**

For pdf, use search function {Search word} to find all the revised locations.

<b>Last digit of the Code No.</b>	<b>Issue month</b>	<b>Main Revised Point and Corrective Measures {Search word}</b>	<b>Reference Page</b>
<b>1</b>	2013.08	Change to the Quick Hitch type at "[2] FRONT LOADER (1) Bucket, Boom and Hydraulic Cylinders". {Bucket (Quick Hitch)}	8-S6
<b>2</b>	2015.05	Added RCK54D-26BX and RCK60D-26BX Drive Over Mower Decks.	
<b>3</b>	2016.03	Revise Maintenance Intervals	G-17
<b>4</b>	2017.02	Changed Checking Hydraulic Pump Oil Flow	5-S6

# **| INFORMATION**

# INFORMATION

## CONTENTS

- 1. SAFETY FIRST ..... I-1
- 2. SAFETY DECALS ..... I-4
  - [1] BX TRACTOR ..... I-4
  - [2] MOWER ..... I-8
  - [3] FRONT LOADER ..... I-12
- 3. SPECIFICATIONS ..... I-14
  - [1] BX TRACTOR ..... I-14
  - [2] MOWER ..... I-15
    - (1) RCK48-18BX, RCK54-23BX, RCK60B-23BX, RCK48P-18BX and RCK54P-23BX ..... I-15
    - (2) RCK54D-26BX and RCK60D-26BX ..... I-16
  - [3] FRONT LOADER ..... I-17
- 4. TRAVELING SPEEDS ..... I-20
- 5. DIMENSIONS ..... I-21

# 1. SAFETY FIRST

## SAFETY FIRST

- This symbol, the industry's "Safety Alert Symbol", is used throughout this manual and on labels on the machine itself to warn of the possibility of personal injury. Read these instructions carefully.
- It is essential that you read the instructions and safety regulations before you try to repair or use this unit.

### DANGER

- Indicates an imminently hazardous situation which, if not avoided, will result in death or serious injury.

### WARNING

- Indicates a potentially hazardous situation which, if not avoided, could result in death or serious injury.

### CAUTION

- Indicates a potentially hazardous situation which, if not avoided, could result in minor or moderate injury.

### ■ IMPORTANT

- Indicates that equipment or property damage could result if instructions are not followed.

### ■ NOTE

- Gives helpful information.

WSM000001INI0001US1

### BEFORE YOU START SERVICE

- Read all instructions and safety instructions in this manual and on your machine safety decals.
- Clean the work area and machine.
- Park the machine on a stable and level ground, and set the parking brake.
- Lower the implement to the ground.
- Stop the engine, then remove the key.
- Disconnect the battery negative cable.
- Hang a "DO NOT OPERATE" tag in the operator station.

WSM000001INI0010US0

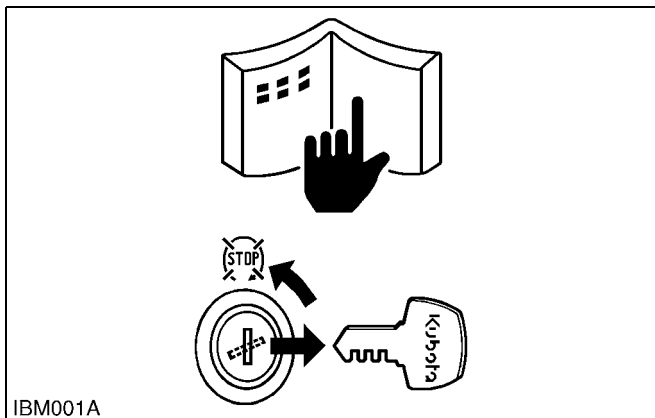

IBM001A

### START SAFELY

- Do not do the procedures below when you start the engine.
  - short across starter terminals
  - bypass the safety start switch
- Do not alter or remove any part of machine safety system.
- Before you start the engine, make sure that all shift levers are in neutral positions or in disengaged positions.
- Do not start the engine when you stay on the ground. Start the engine only from operator's seat.

WSM000001INI0015US0

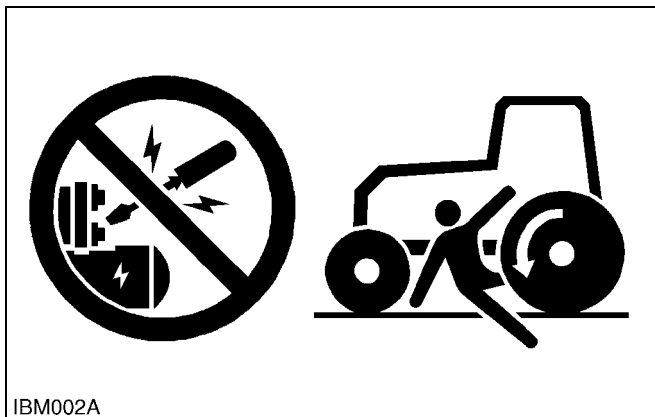

IBM002A

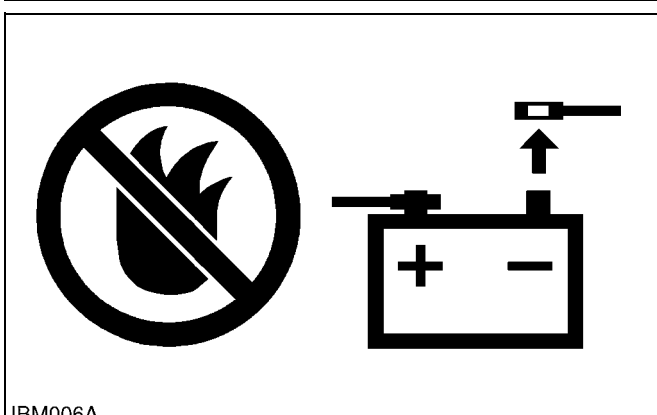
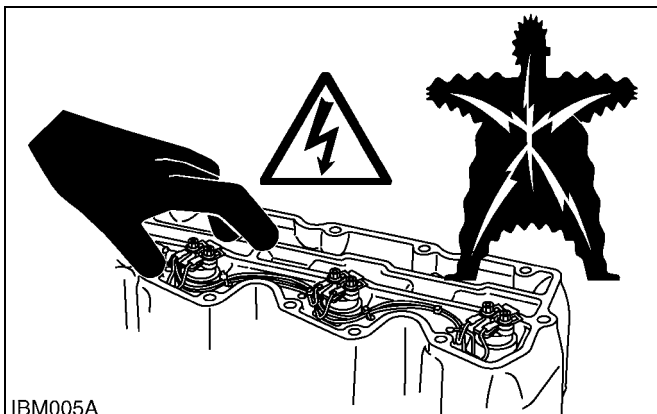
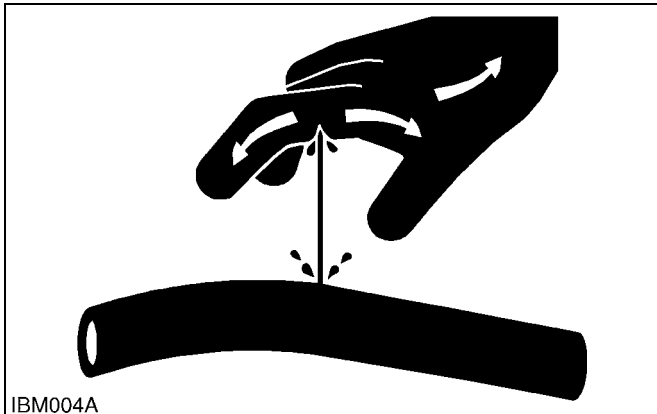
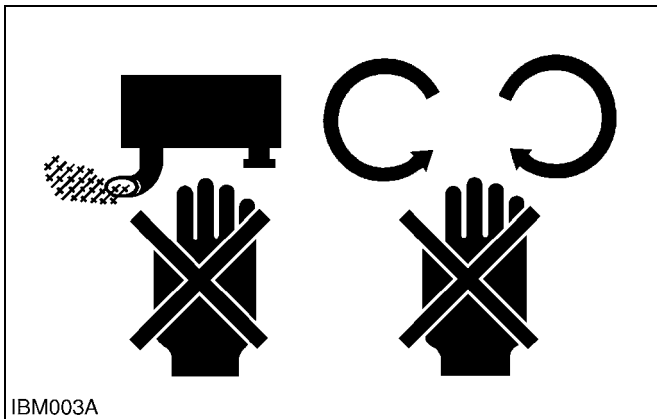

**OPERATE SAFELY**

- Do not use the machine after you consume alcohol or medication or when you are tired.
- Put on applicable clothing and safety equipment.
- Use applicable tools only. Do not use alternative tools or parts.
- When 2 or more persons do servicing, make sure that you do it safely.
- Do not operate below the machine that only a jack holds. Always use a safety stand to hold the machine.
- Do not touch the hot parts or parts that turn when the engine operates.
- Do not remove the radiator cap when the engine operates, or immediately after it stops. If not, hot water can spout out from the radiator. Only remove the radiator cap when it is at a sufficiently low temperature to touch with bare hands. Slowly loosen the cap to release the pressure before you remove it fully.
- Released fluid (fuel or hydraulic oil) under pressure can cause damage to the skin and cause serious injury. Release the pressure before you disconnect hydraulic or fuel lines. Tighten all connections before you apply the pressure.
- Do not open a fuel system under high pressure. The fluid under high pressure that stays in fuel lines can cause serious injury. Do not disconnect or repair the fuel lines, sensors, or any other components between the fuel pump and injectors on engines with a common rail fuel system under high pressure.
- Put on an applicable ear protective device (earmuffs or earplugs) to prevent injury against loud noises.
- Be careful about electric shock. The engine generates a high voltage of more than DC100 V in the ECU and is applied to the injector.

WSM000001INI0012US0

**PREVENT A FIRE**

- Fuel is very flammable and explosive under some conditions. Do not smoke or let flames or sparks in your work area.
- To prevent sparks from an accidental short circuit, always disconnect the battery negative cable first and connect it last.
- The battery gas can cause an explosion. Keep the sparks and open flame away from the top of battery, especially when you charge the battery.
- Make sure that you do not spill fuel on the engine.

WSM000001INI0005US0

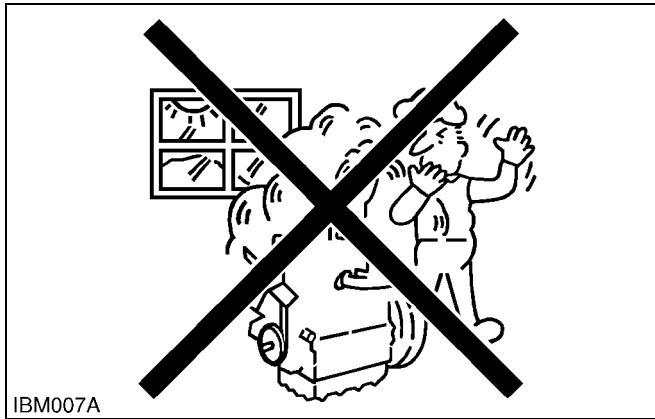

**KEEP A GOOD AIRFLOW IN THE WORK AREA**

- If the engine is in operation, make sure that the area has good airflow. Do not operate the engine in a closed area. The exhaust gas contains poisonous carbon monoxide.

WSM000001INI0006US0

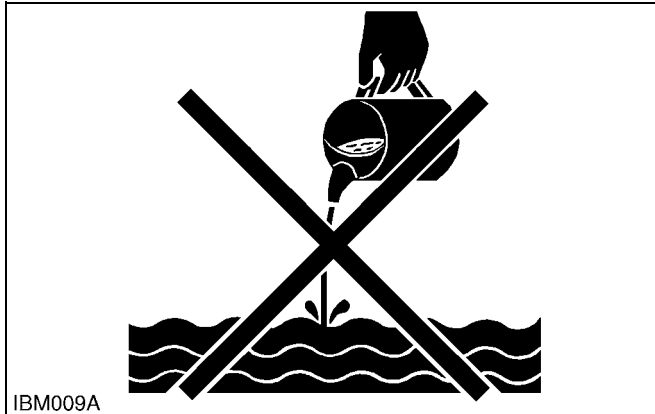

**DISCARD FLUIDS CORRECTLY**

- Do not discard fluids on the ground, down the drain, into a stream, pond, or lake. Obey related environmental protection regulations when you discard oil, fuel, coolant, electrolyte and other dangerous waste.

WSM000001INI0007US0

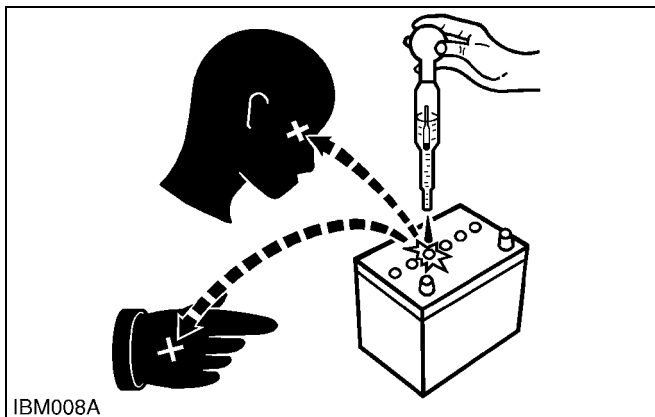

**PREVENT ACID BURNS**

- Keep electrolyte away from your eyes, hands and clothing. Sulfuric acid in battery electrolyte is poisonous and it can burn your skin and clothing and cause blindness. If you spill electrolyte on yourself, clean yourself with water, and get medical aid immediately.

WSM000001INI0008US0

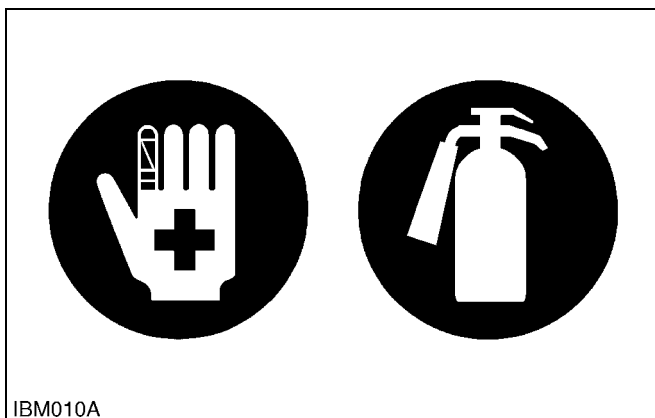

**PREPARE FOR EMERGENCIES**

- Keep a first aid kit and fire extinguisher ready at all times.
- Keep the emergency contact telephone numbers near your telephone at all times.

WSM000001INI0009US0



## 2. SAFETY DECALS

The following safety decals are installed on the machine. If a decal becomes damaged, illegible or is not on the machine, replace it. The decal part number is listed in the parts list.

WSM000001INI0013US0

### [1] BX TRACTOR

(1) Part No. K2651-6557-2



**WARNING**  
TO AVOID PERSONAL INJURY OR DEATH FROM ROLL-OVER:

1. Kubota recommends the use of a Roll-Over Protective Structures (ROPS) and seat belt in almost all applications.
2. Remove the ROPS only when it substantially interferes with operation or itself presents a safety risk. (Examples include work in orchards and vineyards.) ALWAYS REINSTALL IT BEFORE USING THE TRACTOR IN OTHER APPLICATIONS.
3. Never use just the seat belt or just the ROPS. They must be used together. For further details, consult your Operator's Manual or your local dealer.

1AGA JAXAP041E

(2) Part No. K2561-6548-2

**CAUTION**

**TO AVOID PERSONAL INJURY:**

1. Read and understand the operator's manual before operation.
2. Before starting the engine, make sure that everyone is at a safe distance from the tractor and that the PTO is OFF.
3. Do not allow passengers on the tractor at any time.
4. Before allowing other people to use the tractor, have them read the operator's manual.
5. Check the tightness of all nuts and bolts regularly.
6. Keep all shields in place and stay away from all moving parts.
7. Slow down for turns, or rough roads.
8. On public roads use SMV emblem and hazard lights, if required by local traffic and safety regulations.
9. Pull only from the hitch.
10. Before dismounting lower the implement to the ground, set the parking brake, stop the engine and remove the key.
11. Securely support tractor and implements before working underneath.

1AGA JAXAP042E

(3) Part No. K2561-6552-2

Do not put hands under the rear fender.



**WARNING**

**TO AVOID PERSONAL INJURY: KEEP HANDS AWAY FROM PINCH POINTS OF LIFT ARMS.**

1AGA JAXAP047E

(4) Part No. K1272-6585-2

Diesel fuel only No fire



**ULTRA LOW SULFUR DIESEL FUEL ONLY**

1BDAHAOAP002A

(5) Part No. K2591-6557-2



**WARNING**

**TO AVOID PERSONAL INJURY OR DEATH FROM ROLL-OVER:**

1. Keep Roll-Over Protective Structures (ROPS) in the upright and locked position.
2. Fasten SEAT BELT before operating.



**THERE IS NO OPERATOR PROTECTION WHEN THE ROPS IS IN THE FOLDED POSITION.**

1. Check the operating area and fold the ROPS only when absolutely necessary.
2. Do not wear SEAT BELT if ROPS is folded.
3. Raise and lock ROPS as soon as vertical clearance allows.
4. Read ROPS related instructions and warnings.

1HNAAACAP014E

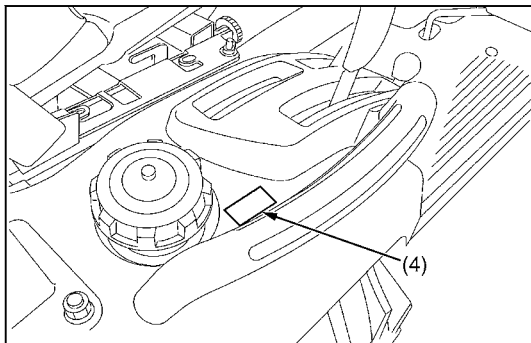
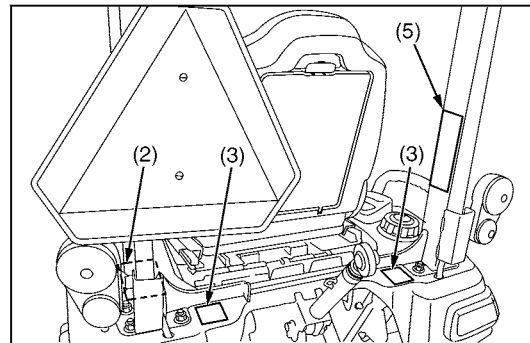
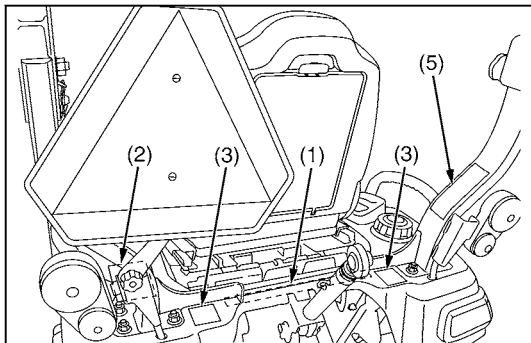

9Y1210855IC1011US

9Y1210855INI0001US0

(1) Part No. K2581-6554-1

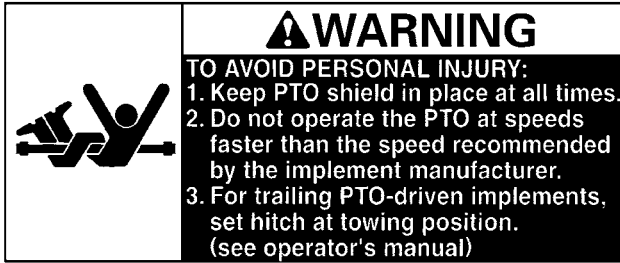

**⚠ WARNING**  
**TO AVOID PERSONAL INJURY:**  
 1. Keep PTO shield in place at all times.  
 2. Do not operate the PTO at speeds faster than the speed recommended by the implement manufacturer.  
 3. For trailing PTO-driven implements, set hitch at towing position. (see operator's manual)

1AGA JAXAP044E

(2) Part No. K2581-6555-1



**⚠ CAUTION**  
**TO AVOID PERSONAL INJURY FROM SEPARATION:**  
 GROOVE →  
 ← GROOVE  
**DO NOT EXTEND LIFT ROD BEYOND THE GROOVE ON THE THREADED ROD.**

1AGA JAXAP043E

(3) Part No. K2581-6556-1



**⚠ WARNING**  
**TO AVOID PERSONAL INJURY:**  
 1. Attach pulled or towed loads to the hitch only.  
 2. Use the 3-point hitch only with equipment designed for 3-point hitch usage.

1AGA JAXAP046E

(4) Part No. K2651-6568-1



**⚠ WARNING**  
 Operation of this equipment may create sparks that can start fires around dry vegetation. A spark arrester may be required. The operator should contact local fire agencies for laws or regulations relating to fire prevention requirements.

1AYAACAAP1000

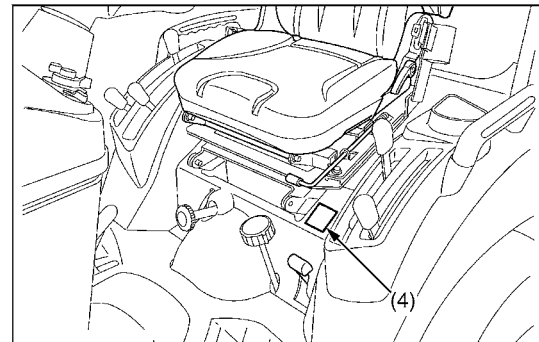
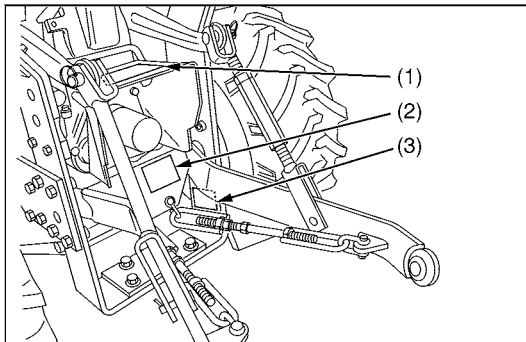

9Y1210855ICI012US

9Y1210855INI0002US0

(1) Part No. K2581-6541-1

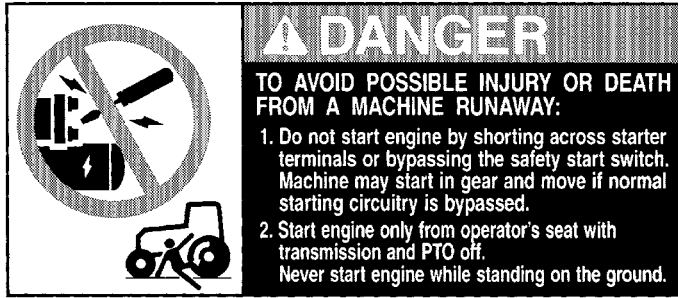

**DANGER**  
**TO AVOID POSSIBLE INJURY OR DEATH FROM A MACHINE RUNAWAY:**  
 1. Do not start engine by shorting across starter terminals or bypassing the safety start switch. Machine may start in gear and move if normal starting circuitry is bypassed.  
 2. Start engine only from operator's seat with transmission and PTO off. Never start engine while standing on the ground.

1AGAJAXAP048E

(2) [BX1870D, BX2370D]  
 Part No. K2581-6547-1  
 Stay clear of engine fan and fan belt.



1AGAJAXAP049E

(3) Part No. K2581-6542-1  
 Do not touch hot surface like muffler, etc..

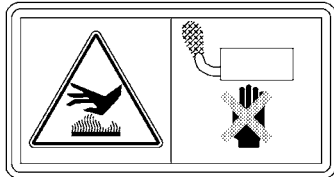

1AGAJAXAP050E

(4) Part No. K2581-6543-1  
 Stay clear of engine fan and fan belt.

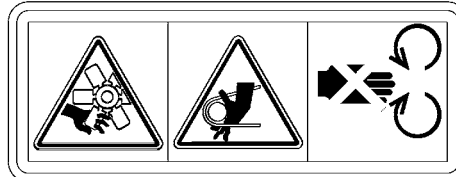

1AGAJAXAP052E

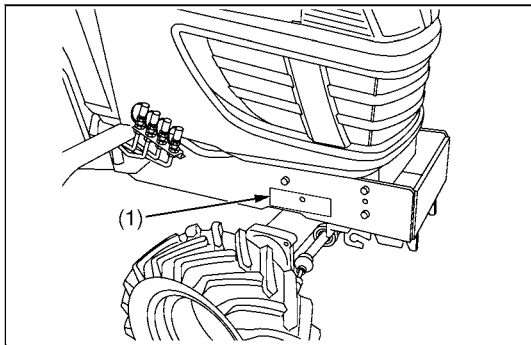

[BX1870D, BX2370D]

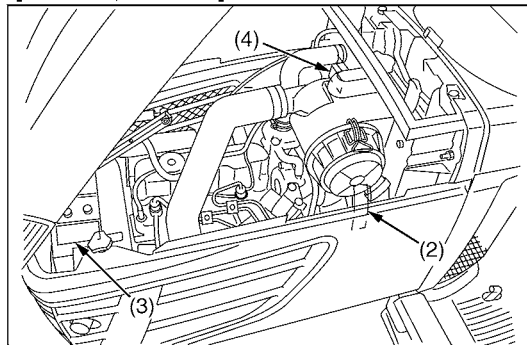

[BX2670D]

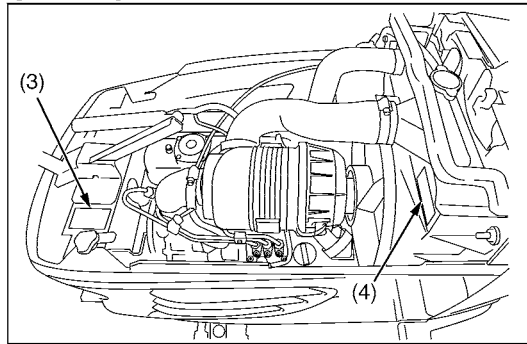

9Y1210855IC1003US

9Y1210855INI0003US0

(1) Part No. K1221-6118-1

<p><b>MAINTENANCE FREE • SANS ENTRETIEN • LIBRE DE MANTENIMIENTO</b></p> <p><b>⚠ DANGER/POISON ¡PELIGRO/VENENO!</b></p>			
<p><b>SHIELD EYES.</b> EXPLOSIVE GASES CAN CAUSE BLINDNESS OR INJURY.</p>	<p><b>NO</b> • SPARKS • FLAMES • SMOKING</p>	<p><b>SULFURIC ACID</b> CAN CAUSE BLINDNESS OR SEVERE BURNS.</p>	<p><b>FLUSH EYES IMMEDIATELY WITH WATER. GET MEDICAL HELP FAST.</b></p>
<p><b>PROTÉJEZ LOS OJOS.</b> LOS GAZ EXPLOSIVOS PUEDEN LESAR O DAÑAR LA VISTA.</p>	<p><b>EVITAR</b> • LES ÉTINCELLES • LES FLAMMES • DE FUMER</p>	<p><b>L'ACIDE SULFURIQUE</b> PEUT CAUSER LA CECITE OU DES BRULURES GRAVES.</p>	<p><b>RINCEZ LES YEUX A L'EAU IMMEDIATEMENT CONSULTEZ UN MEDECIN RAPIDEMENT.</b></p>
<p><b>PROTEJA LOS OJOS.</b> LOS GASES EXPLOSIVOS PUEDEN CAUSAR DAÑOS O CEGUERA.</p>	<p><b>NO</b> • CHISPAS • FLAMAS • CIGARROS</p>	<p><b>ACIDO SULFURICO</b> PUEDE CAUSAR CEGUERA O QUEMADURAS FUERTES.</p>	<p><b>ENJUAGUE LOS OJOS INMEDIATAMENTE CON AGUA. ACUDA RAPIDO CON EL MEDICO.</b></p>
<p><b>KEEP OUT OF THE REACH OF CHILDREN. DO NOT TIP. DO NOT OPEN BATTERY!</b> <b>TENIR HORS DE LA PORTÉE DES ENFANTS. NE PAS RENVERSEZ. NE PAS OUVRIR LA BATTERIE!</b> <b>ALEJESE DEL ALCANCE DE LOS NIÑOS. NO VOLTEAR. ¡NO ABRIR LA BATERIA!</b></p>			
<p><b>CALIFORNIA PROPOSITION 65 WARNING:</b> Batteries, battery posts, terminals and related accessories contain lead and lead compounds and other chemicals known to the State of California to cause cancer and birth defects or other reproductive harm. <b>WASH HANDS AFTER HANDLING.</b></p>			
<p><b>RECYCLE</b></p>		<p><b>MADE IN U.S.A.</b> FABRIQUE AUX E.U.A. HECHO EN E.U.A.</p>	

1BDABDMP013A

(2) Part No. K2591-6564-2

**⚠ WARNING**

Never modify or repair a ROPS because welding, grinding, drilling or cutting any portion may weaken the structure.

**⚠ CAUTION**

**TO AVOID PERSONAL INJURY WHEN RAISING OR FOLDING ROPS:**

1. Set parking brake and stop engine.
2. Remove any obstruction that may prevent raising or folding of the ROPS.
3. Do not allow any bystanders.
4. Always perform function from a stable position at the rear of the tractor.
5. Hold the top of the ROPS securely when raising or folding.
6. Make sure all pins are installed and locked.

1HNAAACAP013E

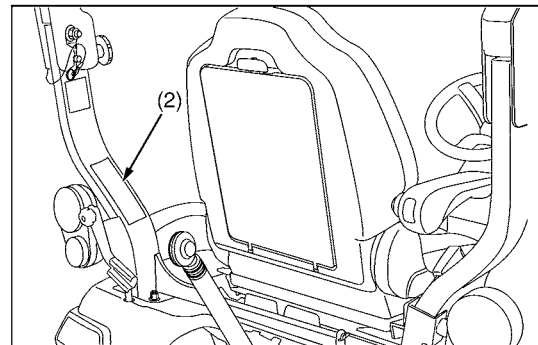
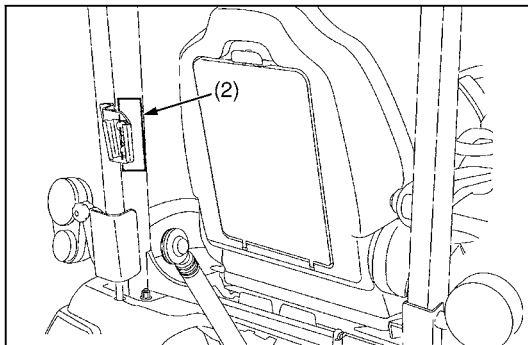
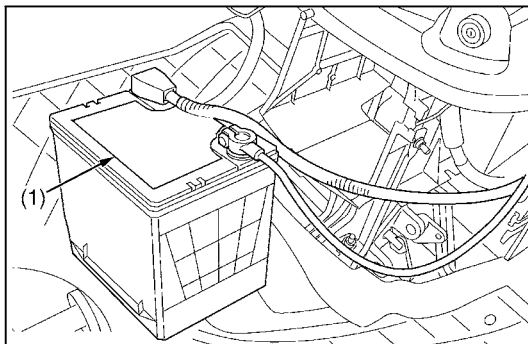

9Y1210855ICI013US

9Y1210855INI0004US0

**CARE OF DANGER, WARNING AND CAUTION LABELS**

1. Keep danger, warning and caution labels clean and free from obstructing material.
2. Clean danger, warning and caution labels with soap and water, dry with a soft cloth.
3. Replace damaged or missing danger, warning and caution labels with new labels.
4. If a component with danger, warning and caution label(s) affixed is replaced with new part, make sure new label(s) is (are) attached in the same location(s) as the replaced component.
5. Mount new danger, warning and caution labels by applying on a clean dry surface and pressing any bubbles to outside edge.

9Y1210855INI0005US0

## [2] MOWER

[RCK60B-23BX, RCK54-23BX, RCK48-18BX]

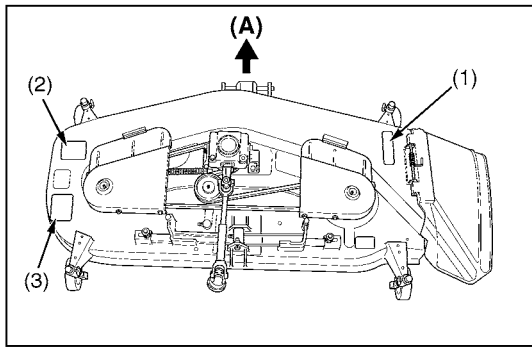

(A) Forward

(1) Part No. K5112-7311-1

(3) Part No. K5763-4715-1



1BDACADAP003E



1BDACADAP002E

(2) Part No. K5112-7312-1



1BDACADAP004E

9Y1210855ICI005US

9Y1210855INI0006US0

[RCK54P-23BX]

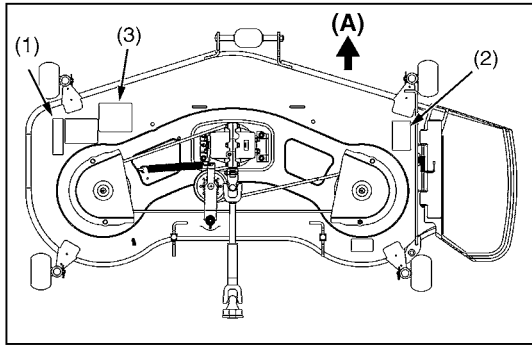

(A) Forward

(1) Part No. K5617-7311-1



1BDABBSAP0030

(2) Part No. K5617-7312-1



1BDABBSAP0020

(3) Part No. K5763-4715-1



1BDACADAP002E

[RCK48P-18BX]

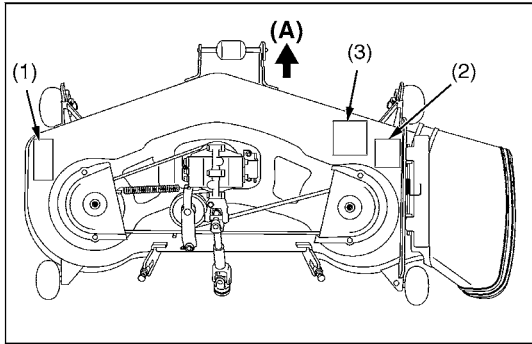

(A) Forward

(1) Part No. K5617-7311-1



1BDABBSAP0030

(2) Part No. K5617-7312-1



1BDABBSAP0020

(3) Part No. K5763-4715-1



1BDACADAP002E

9Y1210855ICI007US

9Y1210855INI0008US0

[RCK60D-26BX]

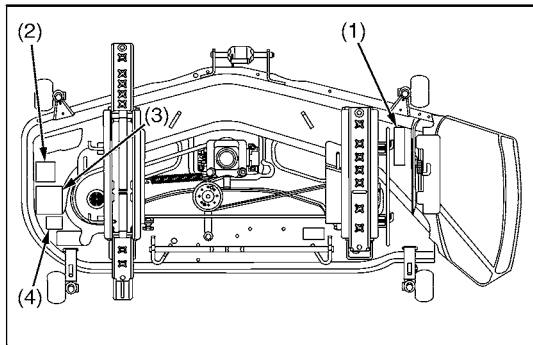

(1) Part No. K5112-7315-2



1BDACADAP003E

(2) Part No. K5112-7312-2



1BDACADAP004E

[RCK54D-26BX]

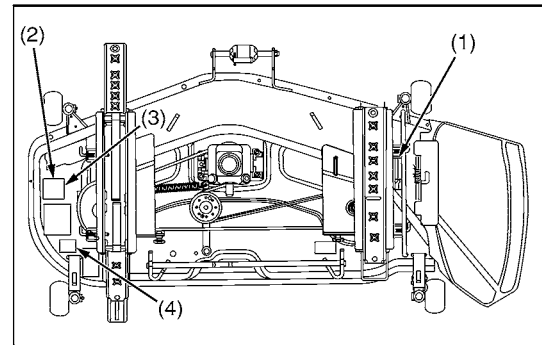

(3) Part No. K5384-4715-1



1BDACBLAP051A

(4) Part No. K5384-4171-1

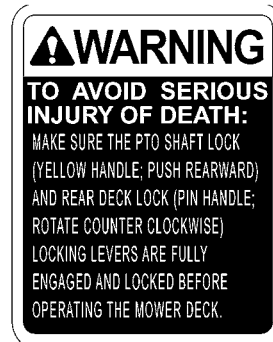

1BDACAMAP095A

9Y1210855ICI010US

9Y1210855INI0018US0

**CARE OF DANGER, WARNING AND CAUTION LABELS**

1. Keep danger, warning and caution labels clean and free from obstructing material.
2. Clean danger, warning and caution labels with soap and water, dry with a soft cloth.
3. Replace damaged or missing danger, warning and caution labels with new labels.
4. If a component with danger, warning and caution label(s) affixed is replaced with new part, make sure new label(s) is (are) attached in the same location(s) as the replaced component.
5. Mount new danger, warning and caution labels by applying on a clean dry surface and pressing any bubbles to outside edge.

9Y1210855INI0005US0



### [3] FRONT LOADER

(1) Part No. 7J246-5645-1

**CAUTION**

**TO AVOID PERSONAL INJURY :**

1. Observe safety precautions in loader and tractor Operator's Manual.
2. Operate the loader from tractor seat only.
3. Keep children, others and livestock away when operating loader and tractor.
4. Avoid holes, loose ground, and rocks which may cause tractor / loader to tip.
5. Make sure approved bucket is attached before removing loader from tractor.
6. When parking or storing, choose flat and hard ground. Lower the bucket to the ground, set brakes and remove key before leaving tractor.
7. Before disconnecting hydraulic lines, relieve all hydraulic pressure.

1AIABAHAP019A

(2) Part No. 7J246-5641-1

**DANGER**

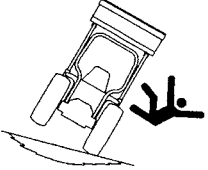

**TO AVOID SERIOUS INJURY OR DEATH CAUSED BY ROLLOVERS :**

1. ROPS and a fastened seat belt are strongly recommended in almost all applications. Foldable ROPS should be in upright and locked position if equipped.
2. Adjust rear wheels to the widest setting that is suitable for the work.
3. Add recommended wheel ballast and rear weight for stability.
4. DO NOT drive on steep slopes or unstable surfaces.
5. Carry loader arms at low position during transport. Move and turn tractor at slow speeds.

1AIABAHAP017A

(3) Part No. 7J246-5643-1

**DANGER**



**TO AVOID SERIOUS INJURY OR DEATH CAUSED BY FALLING LOADS :**

1. Load on raised bucket or fork can fall or roll back onto operator causing serious injury or death.
2. Use approved clamping and / or guard attachments for handling large, loose or shiftable loads such as bales, posts, sheets of plywood etc.
3. Carry loads as low as possible.

1AIABAHAP016A

(4) Part No. 7J246-5642-1

**DANGER**



**TO AVOID SERIOUS INJURY OR DEATH CAUSED BY CONTACT WITH ELECTRIC LINES:**

- Check overhead clearance.

1AIABAHAP018A

(5) Part No. 7J246-5644-2

**WARNING**



**TO AVOID INJURY FROM FALLS OR BEING CRUSHED :**

1. DO NOT stand or work under raised loader or bucket.
2. DO NOT use loader as jack for servicing.
3. DO NOT use loader as a work platform.
4. NEVER connect chain, cable or rope to loader bucket while operating loader.

1AIABAHAP020A

(6) Part No. 7J266-5649-2

**CAUTION**

**TO AVOID INJURY FROM CRUSHING :**

1. Do not utilize the valve lock for machine maintenance or repair.
2. The valve lock is to prevent accidental actuation when implement is not in use or during transport.

1AIABACAP077A

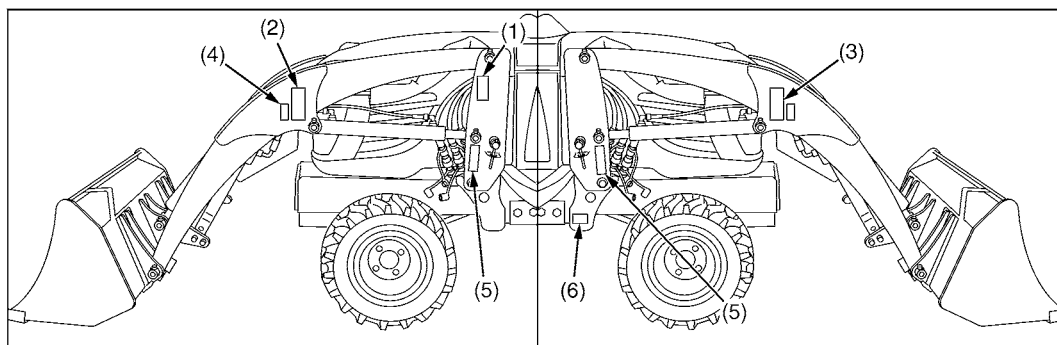

\*The labels (2), (3), (4) are attached to inside of the boom.

**[BX6315 QUICK COUPLER]**

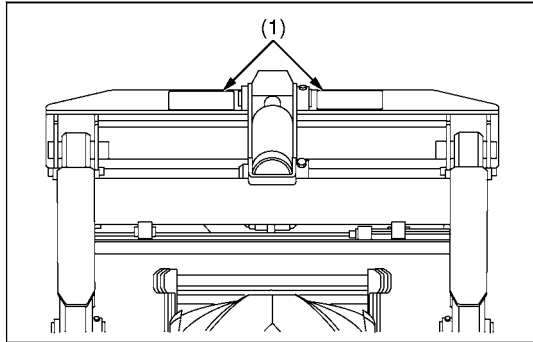

(1) Part No. 7J619-3616-1

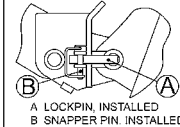

**CAUTION**

TO AVOID MACHINE DAMAGE OR PERSONAL INJURY

1. LOCKPINS AND SNAPPER PINS MUST BE PROPERLY INSTALLED BEFORE MOVING THE IMPLEMENT.
2. KEEP LOCKPINS AND SNAPPER PINS IN THE QUICK HITCH FRAME AT ALL TIMES.

A LOCKPIN, INSTALLED  
B SNAPPER PIN, INSTALLED

1AGAJB,IAP044E

**[BX6314 PALLET FORK]**

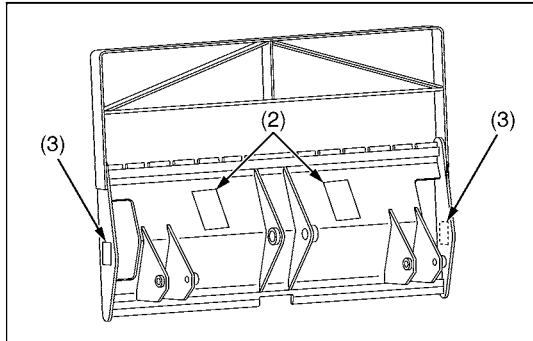

(2) Part No. 7J612-3923-1

**DANGER**

**PALLET FORK SPECIFICATION**

- Rated capacity  
LA203(A) 180 LBS ( 82 kg)  
LA243(A), LA240(A) 310 LBS (142 kg)
- The distance to its center of gravity from the attachment face  
LA203(A), LA243(A), LA240(A) :17.6 in(448 mm)
- The weight of the attachment :90 LBS (41 kg)

**TO AVOID PERSONAL INJURY OR DEATH CAUSED BY ROLLOVER**

- Do not exceed rated load listed above.
- Use rear implement and tire ballast recommended in loader operator's manual.
- Operate tractor slowly taking special care when turning.

1A1ABCDAP035A

(3) Part No. 7J246-5643-1

**DANGER**



**TO AVOID SERIOUS INJURY OR DEATH CAUSED BY FALLING LOADS:**

1. Load on raised bucket or fork can fall or roll back onto operator causing serious injury or death.
2. Use approved clamping and / or guard attachments for handling large, loose or shiftable loads such as bales, posts, sheets of plywood etc.
3. Carry loads as low as possible.

1A1ABAHAP016A

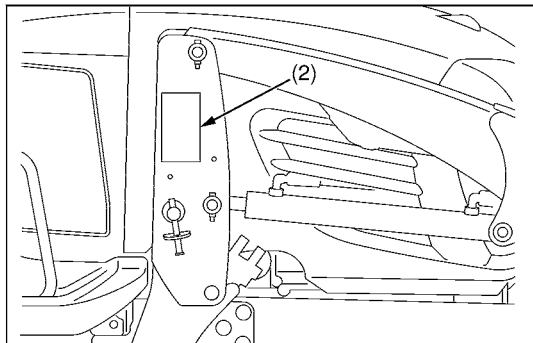

9Y1210855ICI009US

9Y1210855INI0010US0

**CARE OF DANGER, WARNING AND CAUTION LABELS**

1. Keep danger, warning and caution labels clean and free from obstructing material.
2. Clean danger, warning and caution labels with soap and water, dry with a soft cloth.
3. Replace damaged or missing danger, warning and caution labels with new labels.
4. If a component with danger, warning and caution label(s) affixed is replaced with new part, make sure new label(s) is (are) attached in the same location(s) as the replaced component.
5. Mount new danger, warning and caution labels by applying on a clean dry surface and pressing any bubbles to outside edge.

9Y1210855INI0005US0

### 3. SPECIFICATIONS

#### [1] BX TRACTOR

Model		BX1870D	BX2370D	BX2670D	
PTO power		10.2 kW (13.7 HP)*	13.2 kW (17.7 HP)*	14.5 kW (19.5 HP)*	
Engine	Maker	KUBOTA			
	Model	D722-E4-BX-1	D902-E4-BX-1	D1005-E4-BX-1	
	Type	Indirect Injection, vertical, water-cooled, 4-cycle diesel			
	Number of cylinders	3			
	Bore and stroke	67 × 68 mm (2.64 × 2.68 in.)	72 × 73.6 mm (2.83 × 2.90 in.)	76 × 73.6 mm (2.99 × 2.90 in.)	
	Total displacement	719 cm <sup>3</sup> (43.9 cu.in.)	898 cm <sup>3</sup> (54.8 cu.in.)	1001 cm <sup>3</sup> (61.1 cu.in.)	
	Engine gross power	13.4 kW (18.0 HP)**	17.1 kW (23.0 HP)**	19.0 kW (25.5 HP)**	
	Rated revolution	3200 min <sup>-1</sup> (rpm)			
	Maximum torque	44.9 N·m (4.6 kgf·m, 33.1 lbf·ft)	56.1 N·m (5.7 kgf·m, 41.4 lbf·ft)	60.2 N·m (6.1 kgf·m, 44.4 lbf·ft)	
	Battery	12 V, RC: 55 min., CCA: 450 A	12 V, RC: 80 min., CCA: 540 A		
	Fuel	Diesel fuel No. 1 [below -10 °C (14 °F)], Diesel fuel No. 2 [above -10 °C (14 °F)]			
Capacities	Fuel tank	25 L (6.6 U.S.gals, 5.5 Imp.gals)			
	Engine crankcase (with filter)	2.9 L (3.1 U.S.qts, 2.6 Imp.qts)	3.1 L (3.3 U.S.qts, 2.7 Imp.qts)	3.5 L (3.7 U.S.qts, 3.1 Imp.qts)	
	Engine coolant	2.5 L (2.6 U.S.qts, 2.2 Imp.qts)	2.7 L (2.8 U.S.qts, 2.4 Imp.qts)	2.9 L (3.1 U.S.qts, 2.6 Imp.qts)	
	Recovery tank	0.4 L (0.4 U.S.qts, 0.4 Imp.qts)			
	Transmission case	11.6 L (3.06 U.S.gals, 2.55 Imp.gals)			
Dimensions	Overall length (without 3P)		2035 mm (80.1 in.)	2120 mm (83.5 in.)	
	Overall length (with 3P)		2340 mm (92.1 in.)	2425 mm (95.5 in.)	
	Overall width (min. tread)		1145 mm (45.1 in.)		
	Overall height (with ROPS)		2190 mm (86.2 in.)	2215 mm (87.2 in.)	
	Overall height (Top of seat)		1230 mm (48.4 in.)	1255 mm (49.4 in.)	1330 mm (52.4 in.)
	Wheel base		1340 mm (52.8 in.)	1400 mm (55.1 in.)	
	Minimum ground clearance		150 mm (5.9 in.)	175 mm (6.9 in.)	
	Tread	Front	880 mm (34.6 in.)	930 mm (36.3 in.)	
Rear		820 mm (32.2 in.)			
Weight (with ROPS)		610 kg (1345 lbs)	640 kg (1410 lbs)	665 kg (1466 lbs)	
Clutch		N / A			
Travelling system	Tires	Front	16 × 7.50 – 8	18 × 8.50 – 10	
		Rear	24 × 12.00 – 12	26 × 12.00 – 12	
	Steering	Hydrostatic type power steering			
	Transmission	Main: hydrostatic transmission, High-Low gear shift (2 forward and 2 reverse)			
	Brake	Wet disk type			
Min. turning radius (without brake)		2.18 m (7.15 feet)	2.3 m (7.5 feet)		

Model		BX1870D	BX2370D	BX2670D	
Hydraulic unit	Hydraulic control system	Directional control, auto-return lever system			
	Pump capacity	23.5 L/min. (6.2 U.S.gals/min., 5.2 Imp.gals/min.)			
	System pressure	12.3 to 12.8 MPa (126 to 130 kgf/cm <sup>2</sup> , 1790 to 1850 psi)			
	Three point hitch	SAE Category I			
	Three point hitch. Max.lift force	At lift points	5390 N (1210 lbs)***		
		24 in. behind lift points	3040 N (680 lbs)***		
	Remote control valve coupler (Rear: Option)	System	2 valves		
		Coupler	ISO 7341 series A		
Remote control valve coupler (Front: Option)	System	2 valves			
	Coupler	ISO 7341-1 series B			
PTO	Rear	PTO shaft	SAE 1-3/8, 6 splines		
		Revolution	1 speed (540 min <sup>-1</sup> (rpm) at engine 3142 min <sup>-1</sup> (rpm))		
	Mid	PTO shaft	USA No. 5 (KUBOTA 10-tooth) involute spline		
		Revolution	1 speed (2500 min <sup>-1</sup> (rpm) at engine 3043 min <sup>-1</sup> (rpm))		

■ NOTE

- The company reserves the right to change the specifications without notice.
- \* Manufacturer's estimate:
- \*\* SAE J 1995
- \*\*\* See and check "IMPLEMENT LIMITATIONS".

9Y1210855INI0011US0

## [2] MOWER

### (1) RCK48-18BX, RCK54-23BX, RCK60B-23BX, RCK48P-18BX and RCK54P-23BX

Model		RCK48-18BX	RCK54-23BX	RCK60B-23BX	RCK48P-18BX	RCK54P-23BX
Suitable tractor		BX1870D	BX1870D BX2370D	BX2370D BX2670D	BX1870D	BX2370D
Mounting method		Quick-Joint, Parallel linkage				
		Suspended linkage		Self-balance suspended linkage	Suspended linkage	
Adjustment of cutting height		Dial gauge				
Cutting width		1219 mm (48 in.)	1372 mm (54 in.)	1524 mm (60 in.)	1225 mm (48 in.)	1375 mm (54 in.)
Cutting height		25 to 102 mm (1.0 to 4.0 in.)				
Weight (Approx.)		75 kg (165 lbs)	95 kg (210 lbs)	115 kg (250 lbs)	82 kg (181 lbs)	86 kg (190 lbs)
Blade spindle speed		54.7 r/s (3281 rpm)	49.5 r/s (2969 rpm)	44.1 r/s (2647 rpm)	54.7 r/s (3281 rpm)	49.5 r/s (2969 rpm)
Blade tip velocity		72.8 m/s (14331 fpm)	73.8 m/s (14527 fpm)	72.5 m/s (14271 fpm)	72.8 m/s (14331 fpm)	73.8 m/s (14527 fpm)
Blade length		424 mm (16.7 in.)	475 mm (18.7 in.)	523 mm (20.6 in.)	424 mm (16.7 in.)	475 mm (18.7 in.)
Number of blades		3				
Dimensions	Overall length	895 mm (35.2 in.)	928 mm (36.5 in.)	1000 mm (39.4 in.)	881 mm (34.7 in.)	908 mm (35.7 in.)
	Overall width	1544 mm (60.8 in.)	1780 mm (66.5 in.)	1930 mm (76.0 in.)	1550 mm (61.0 in.)	1700 mm (67.0 in.)
	Overall height (Min.)	268 mm (10.5 in.)	281 mm (11.0 in.)	281 mm (11.0 in.)	291 mm (11.5 in.)	291 mm (11.5 in.)

9Y1210855INI0012US0

## (2) RCK54D-26BX and RCK60D-26BX

Model		RCK60D-26BX	RCK54D-26BX
Suitable tractor		BX2370, BX2670	
Mounting method		Drive Over Quick-Joint, Parallel linkage	
		Drive over suspended linkage	
Adjustment of cutting height		Dial gauge	
Cutting width		1524 mm (60 in.)	1372 mm (54 in.)
Cutting height		25 to 102 mm (1.0 to 4.0 in.)	
Weight	Mower	115 kg (250 lbs)	103 kg (227 lbs)
	Mower with frame link	134 kg (295 lbs)	122 kg (269 lbs)
Blade spindle speed		44.1 r/s (2647 rpm)	49.5 r/s (2969 rpm)
Blade tip velocity		72.5 m/s (14271 fpm)	73.8 m/s (14527 fpm)
Blade length		523 mm (20.6 in.)	475 mm (18.7 in.)
Number of blades		3	
Dimensions	Overall length	1000 mm (39.4 in.)	928 mm (36.5 in.)
	Overall width	1930 mm (76.0 in.)	1780 mm (66.5 in.)
	Overall height (Min.)	281 mm (11.0 in.)	
Tire		Industrial, Turf*	

■ **NOTE**

- **\*Bar tires are prohibited from driving over mower deck.**
- **\*\*Remove the frame link when rear attachment is on.**
- **\*\*\*Remove the frame link when snow chain is on.**

9Y1210855INI0019US0

### [3] FRONT LOADER

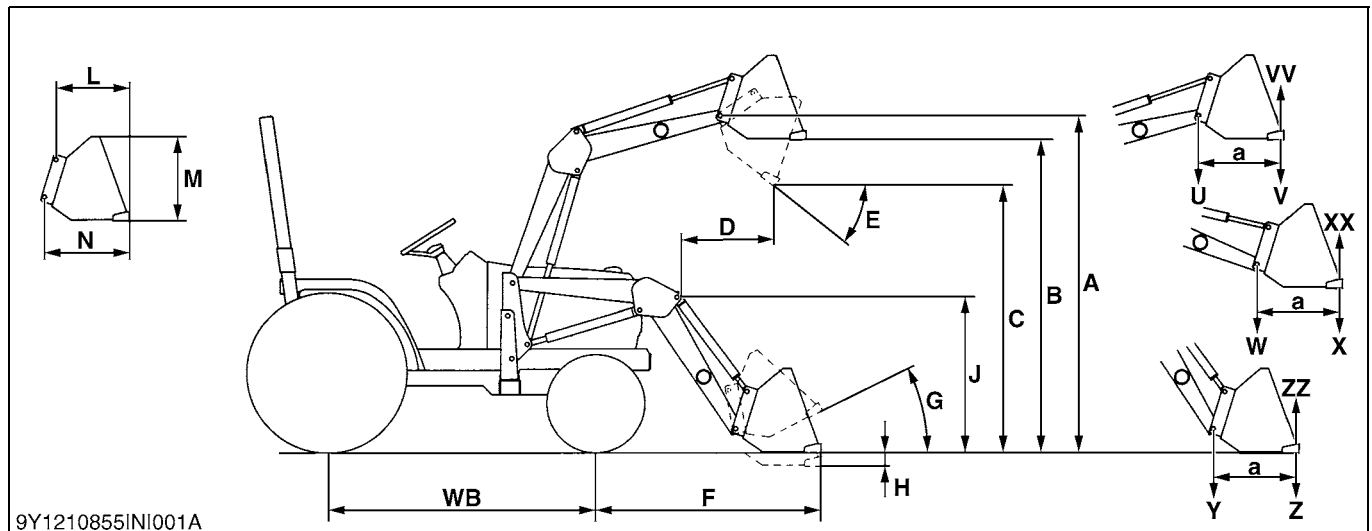

#### Loader Specifications

Loader Model	LA203A	LA243A
Tractor Model	BX1870D (BX1860)	BX2370D and BX2670D (BX2360 and BX2660)
Wheel Base (WB)	1340 mm (52.8 in.)	1400 mm (55.1 in.)
Front Tires	16 × 7.5-8	18 × 8.5-10
Rear Tires	24 × 12-12	26 × 12-12
Boom Cylinder	Bore	40 mm (1.57 in.)
	Stroke	281 mm (11.1 in.)
Bucket Cylinder	Bore	65 mm (2.56 in.)
	Stroke	204 mm (8.03 in.)
Control Valve	One detente float position, two stage bucket dump, power beyond circuit	
Rated Flow	14 L/min. (3.7 U.S.gals/min., 3.1 Imp.gals/min.)	
Maximum Pressure	12.3 MPa (125 kgf/cm <sup>2</sup> , 1778 psi)	
Net Weight (Approximate)	157 kg (346 lbs)	170 kg (375 lbs)

#### Bucket Specifications

Loader Model	LA203A	LA243A
Model	SQUARE 48"	
Type	Rigid	
Width	1219 mm (48.0 in.)	
Depth L	455 mm (17.9 in.)	495 mm (19.5 in.)
Height M	445 mm (17.5 in.)	465 mm (18.3 in.)
Length N	498 mm (19.6 in.)	538 mm (21.2 in.)
Capacity	Struck	0.12 m <sup>3</sup> (4.2 cu.ft.)
	Heaped	0.14 m <sup>3</sup> (4.9 cu.ft.)
Weight	56 kg (123 lbs)	60 kg (132 lbs)

9Y1210855INI0013US0

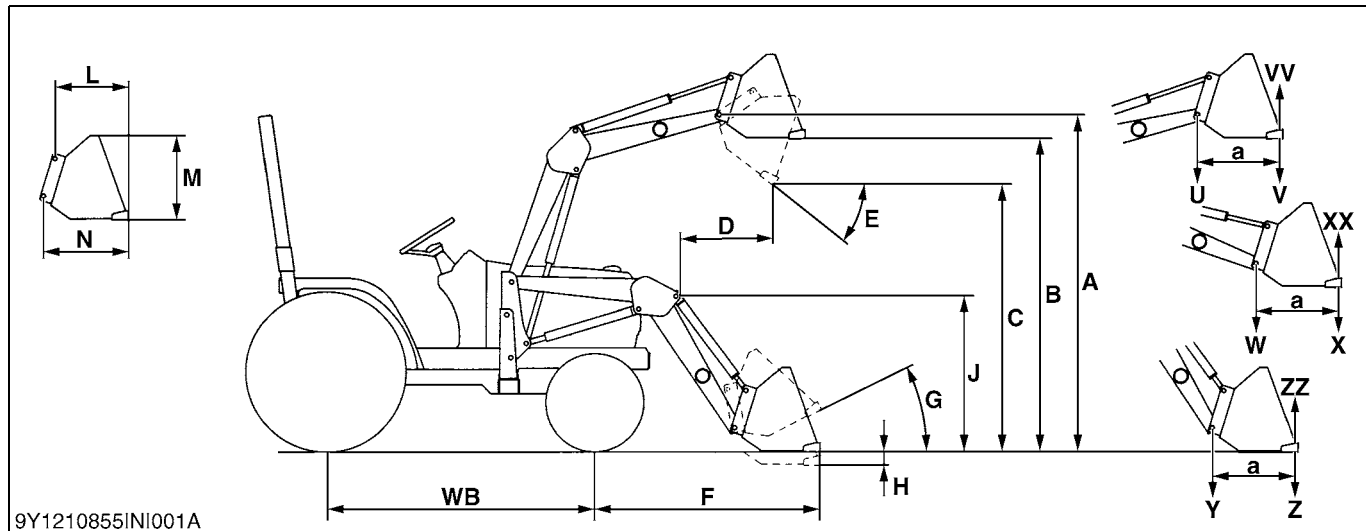

9Y1210855INI001A

**Dimensional Specifications**

Loader Model		LA203A	LA243A
Tractor Model		BX1870D (BX1860)	BX2370D and BX2670D (BX2360 and BX2660)
A	Maximum lift height (To bucket pivot pin)	1810 mm (71.3 in.)	
B	Maximum lift height under level bucket	1680 mm (66.1 in.)	
C	Clearance with bucket dumped	1350 mm (53.1 in.)	1330 mm (52.4 in.)
D	Reach at maximum lift height (Dumping Reach)	720 mm (28.3 in.)	735 mm (28.9 in.)
E	Maximum dump angle	0.784 rad (40 °)	0.785 rad (45 °)
F	Reach with bucket on ground	1330 mm (52.4 in.)	1390 mm (54.7 in.)
G	Bucket roll-back angle	0.59 rad (30 °)	0.51 rad (29 °)
H	Digging depth	100 mm (3.9 in.)	120 mm (4.7 in.)
J	Overall height in carry position	970 mm (38.2 in.)	990 mm (39.0 in.)

**Operational Specifications**

Loader Model		LA203A	LA243A
Tractor Model		BX1870D (BX1860)	BX2370D and BX2670D (BX2360 and BX2660)
U	Lift capacity (Bucket pivot pin, maximum height)	280 kg (617 lbs)	340 kg (750 lbs)
V	Lift capacity (500 mm forward, maximum height)	185 kg (408 lbs)	235 kg (518 lbs)
W	Lift capacity (Bucket pivot pin, 1500 mm (59 in.) height)	315 kg (694 lbs)	375 kg (827 lbs)
X	Lift capacity (1500 mm height)	220 kg (485 lbs)	270 kg (595 lbs)
Y	Breakout force (Bucket pivot pin)	5720 N (1287 lbs)	6290 N (1415 lbs)
Z	Breakout force (500 mm forward)	3920 N (882 lbs)	4410 N (992 lbs)
VV	Bucket roll-back force at maximum height	4460 N (1003 lbs)	4750 N (1069 lbs)
XX	Bucket roll-back force at 1500 mm	5380 N (1210 lbs)	5600 N (1260 lbs)
ZZ	Bucket roll-back force at ground level	5580 N (1255 lbs)	5490 N (1235 lbs)
a	Length	500 mm (19.7 in.)	500 mm (19.7 in.)
Raising time (Rated flow)		2.8 seconds	3.5 seconds
Lowering time (Rated flow)		2.0 seconds	2.7 seconds
Bucket dumping time (Rated flow)		1.8 seconds	1.7 seconds
Bucket roll-back time (Rated flow)		2.1 seconds	2.4 seconds

9Y1210855INI0014US0

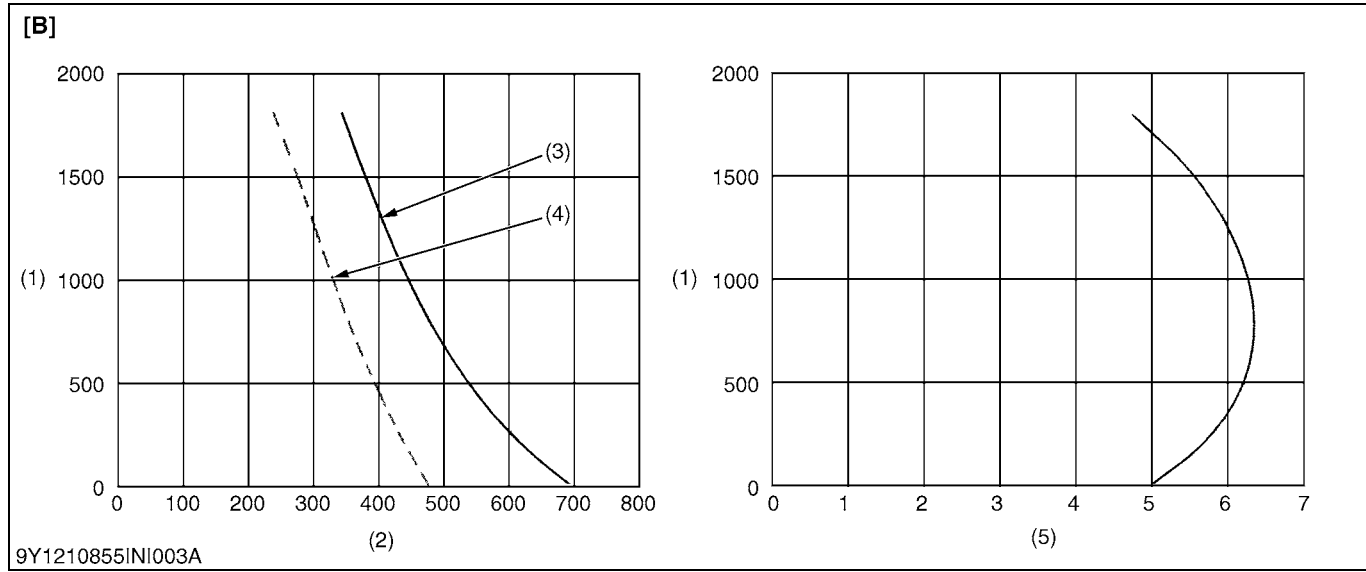
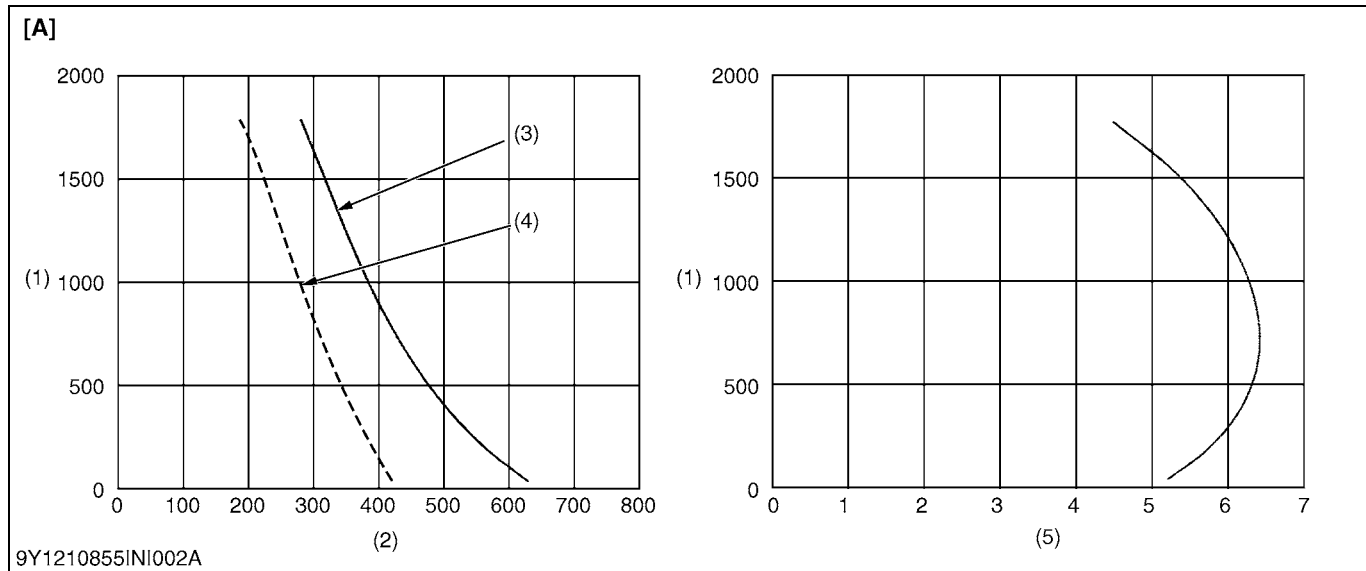

(1) Height (mm)  
 (2) Lift Capacity (kg)

(3) At Pivot Pin  
 (4) 500 mm Forward of Pivot Pin

(5) Rollback Force (kN)

**[A] LA203A**  
**[B] LA243A**

9Y1210855INI0015US0



## 4. TRAVELING SPEEDS

(At rated engine rpm)

Model		BX1870D		BX2370D and BX2670D	
Tire size (Rear)		24 × 12.00 – 12		26 × 12.00 – 12	
	Range gear shift lever	km/h	mph	km/h	mph
Forward	Low	0 to 6.0	0 to 3.7	0 to 6.5	0 to 4.0
	High	0 to 12.5	0 to 7.8	0 to 13.5	0 to 8.4
Reverse	Low	0 to 4.5	0 to 2.8	0 to 5.0	0 to 3.1
	High	0 to 9.5	0 to 5.9	0 to 10.5	0 to 6.5

The company reserves the right to change the specifications without notice.

9Y1210855INI0016US0

# 5. DIMENSIONS

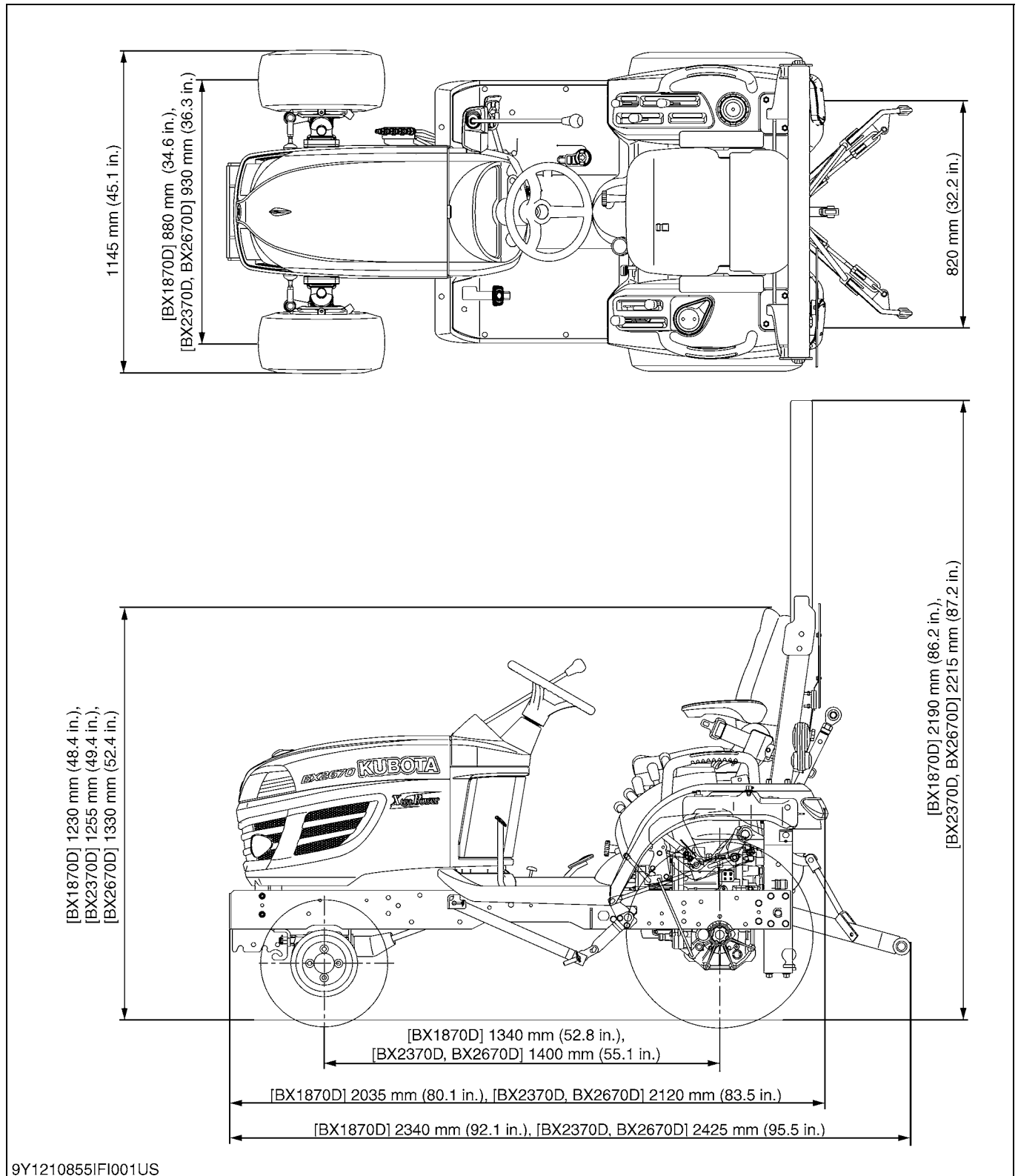

9Y1210855IFI001US

9Y1210855INI0017US0

# **G GENERAL**

# GENERAL

## CONTENTS

1. IDENTIFICATION .....	G-1
[1] TRACTOR IDENTIFICATION.....	G-1
(1) Serial Number and Hour Meter.....	G-1
(2) Cylinder Number.....	G-2
[2] MOWER IDENTIFICATION.....	G-2
[3] FRONT LOADER IDENTIFICATION.....	G-2
2. GENERAL PRECAUTIONS.....	G-3
3. HANDLING PRECAUTIONS FOR ELECTRICAL PARTS AND WIRING .....	G-4
[1] WIRING .....	G-4
[2] BATTERY .....	G-6
[3] FUSE .....	G-6
[4] CONNECTOR .....	G-6
[5] HANDLING OF CIRCUIT TESTER .....	G-7
[6] COLOR OF WIRING .....	G-8
4. LUBRICANTS, FUEL AND COOLANT.....	G-9
[1] BX Tractor .....	G-9
(1) Capacity Table.....	G-9
(2) Engine Oil, Fuel and Transmission Oil .....	G-10
[2] MOWER .....	G-12
(1) Lubricants.....	G-12
[3] FRONT LOADER .....	G-12
(1) Lubricants.....	G-12
5. TIGHTENING TORQUES.....	G-13
[1] GENERAL USE SCREWS, BOLTS AND NUTS (TRACTOR AND MOWER).....	G-13
[2] GENERAL USE SCREWS, BOLTS AND NUTS (FRONT LOADER).....	G-14
[3] STUD BOLTS .....	G-14
[4] METRIC SCREWS, BOLTS AND NUTS .....	G-15
[5] AMERICAN STANDARD SCREWS, BOLTS AND NUTS WITH UNC OR UNF THREADS .....	G-15
[6] PLUGS .....	G-15
[7] HYDRAULIC FITTINGS .....	G-16
(1) Adaptors, Elbows and Others.....	G-16
6. MAINTENANCE CHECK LIST .....	G-17
[1] BX TRACTOR .....	G-17
[2] MOWER .....	G-18
[3] FRONT LOADER .....	G-19
7. CHECK AND MAINTENANCE .....	G-20
[1] BX TRACTOR .....	G-20
(1) Daily Check .....	G-20
(2) Check Points of Initial 50 Hours .....	G-21
(3) Check Points of Every 50 Hours.....	G-23
(4) Check Points of Every 100 Hours.....	G-26
(5) Check Points of Every 200 hours .....	G-31
(6) Check Points of Every 400 Hours.....	G-32
(7) Check Point of Every 800 Hours .....	G-34
(8) Check Point of Every 1000 Hours or 1 year .....	G-34
(9) Check Point of Every 1500 Hours .....	G-34
(10)Check Point of Every 2000 Hours or 2 Years .....	G-35
(11)Check Point of Every 3000 Hours .....	G-37

(12)Check Point of Every 1 Year .....	G-38
(13)Check Points of Every 4 Years.....	G-39
(14)Others.....	G-40
[2] MOWER.....	G-42
(1) Check Points of Daily or Each Use.....	G-42
(2) Check Point of Initial 50 Hours .....	G-46
(3) Check Point of Every 150 Hours.....	G-46
(4) Check Point of Every 1 Year.....	G-46
(5) Check Point of Every 4 Years.....	G-47
[3] FRONT LOADER.....	G-48
(1) Check Points of Each Use or Daily.....	G-48
(2) Check Points of Every 10 Hours.....	G-48
8. SPECIAL TOOLS.....	G-49
[1] SPECIAL TOOLS FOR ENGINE .....	G-49
[2] SPECIAL TOOLS FOR TRACTOR .....	G-58
[3] SPECIAL TOOLS FOR LOADER .....	G-63
9. TIRES .....	G-64
[1] TIRE PRESSURE.....	G-64
[2] WHEEL TREAD.....	G-65
(1) Front Wheels .....	G-65
(2) Rear Wheels.....	G-66
[3] BALLAST .....	G-67
(1) Front Ballast.....	G-67
(2) Rear Ballast .....	G-68
10. IMPLEMENT LIMITATIONS .....	G-69

# 1. IDENTIFICATION

## [1] TRACTOR IDENTIFICATION

### (1) Serial Number and Hour Meter

When contacting your local KUBOTA distributor, always specify engine serial number, tractor serial number and hour meter reading.

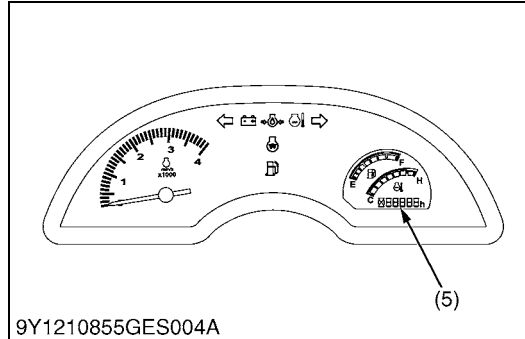
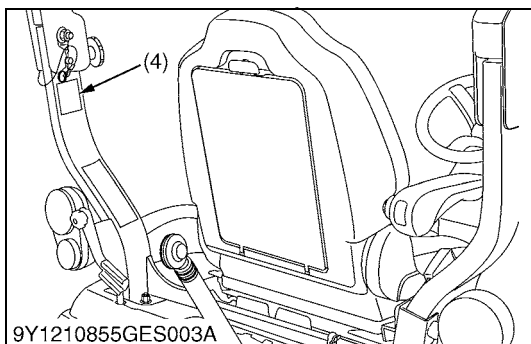
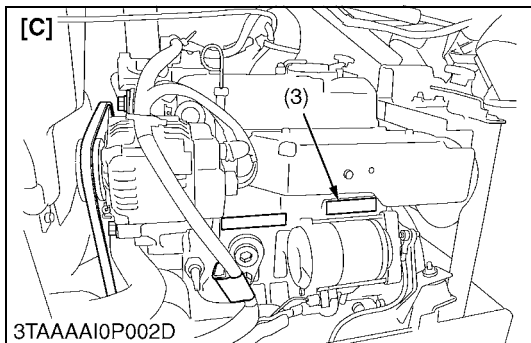
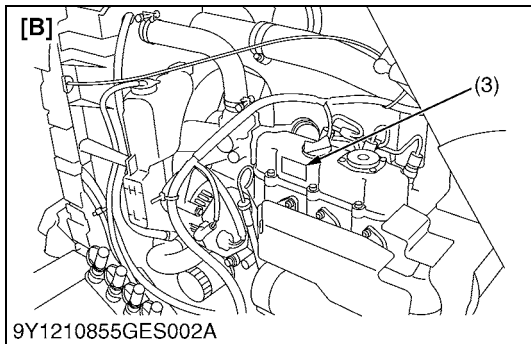
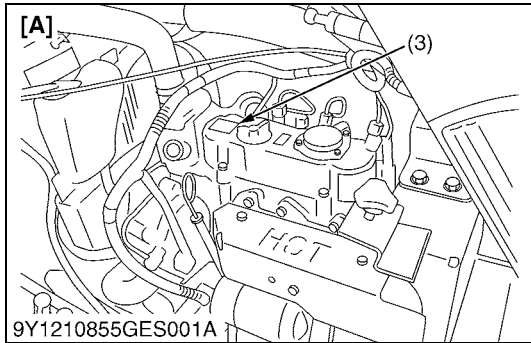
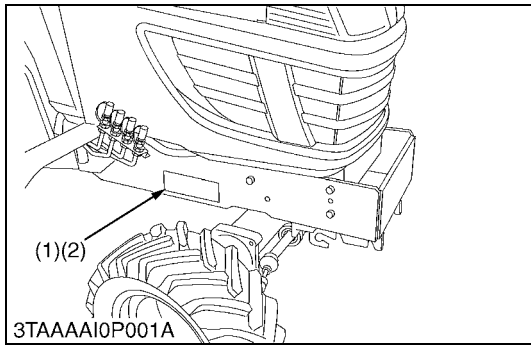

- (1) Tractor Identification Plate
  - (2) Tractor Serial Number
  - (3) Engine Serial Number
  - (4) ROPS Serial Number
  - (5) Hour Meter
- [A] BX1870D
  - [B] BX2370D
  - [C] BX2670D

9Y1210855GEG0001US0

## (2) Cylinder Number

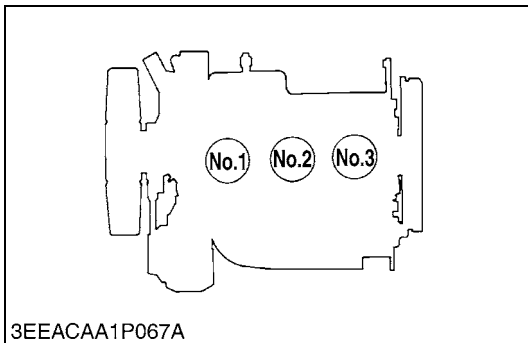

The cylinder numbers of KUBOTA diesel engine are designated as shown in the figure.

The sequence of cylinder numbers is given as No.1, No.2 and No.3 starting from the gear case side.

9Y1210855GEG0002US0

## [2] MOWER IDENTIFICATION

When contacting your local KUBOTA distributor, always specify mower serial number.

(1) Mower Serial Number

[A] RCK60B-23BX, RCK54P-23BX, RCK54-23BX and RCK48-18BX

[B] RCK48P-18BX

[C] RCK54D-26BX and RCK60D-26BX

9Y1210855GEG0003US0

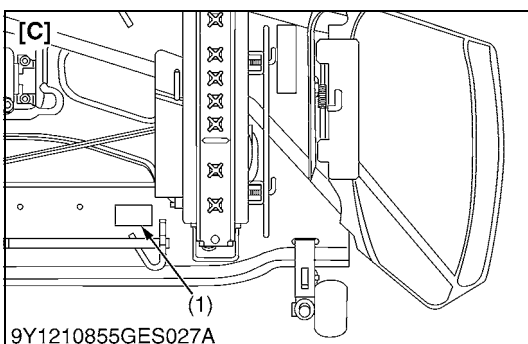
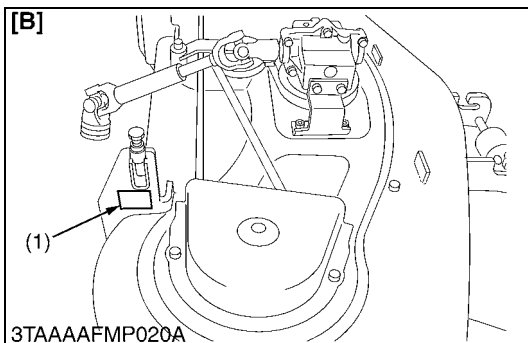
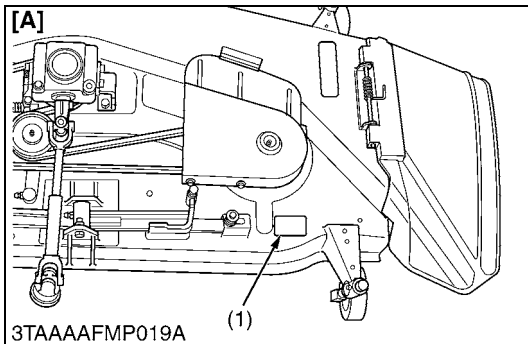

## [3] FRONT LOADER IDENTIFICATION

When contacting your local KUBOTA distributor, always specify front loader model and serial number.

(1) Model / Serial Number

9Y1210855GEG0004US0

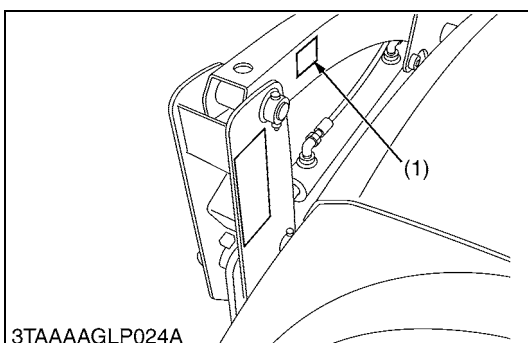

## 2. GENERAL PRECAUTIONS

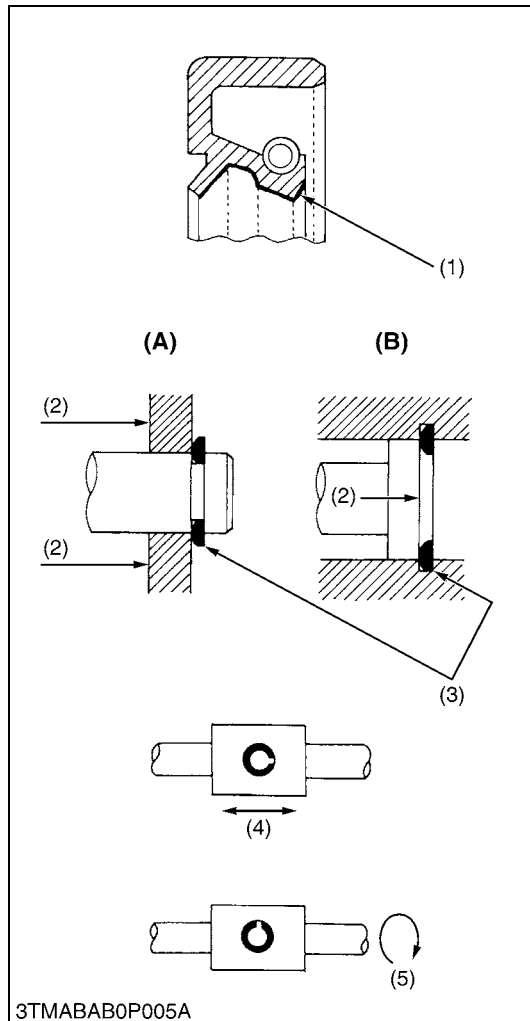

- When you disassemble, carefully put the parts in a clean area to make it easy to find the parts. You must install the screws, bolts and nuts in their initial position to prevent the reassembly errors.
- When it is necessary to use special tools, use KUBOTA special tools. Refer to the drawings when you make special tools that you do not use frequently.
- Before you disassemble or repair machine, make sure that you always disconnect the ground cable from the battery first.
- Remove oil and dirt from parts before you measure.
- Use KUBOTA genuine parts for replacement to keep the machine performance and to make sure of safety.
- You must replace the gaskets and O-rings when you assemble again. Apply grease (1) to new O-rings or oil seals before you assemble.
- When you assemble the external or internal snap rings, make sure that the sharp edge (3) faces against the direction from which force (2) is applied.
- When inserting spring pins, their splits must face the direction from which a force is applied. See the figure on the left side.
- To prevent damage to the hydraulic system, use only specified fluid or equivalent.
- Clean the parts before you measure them.
- Tighten the fittings to the specified torque. Too much torque can cause damage to the hydraulic units or the fittings. Not sufficient torque can cause oil leakage.
- When you use a new hose or pipe, tighten the nuts to the specified torque. Then loosen (approx. by 45°) and let them be stable before you tighten to the specified torque (This is not applied to the parts with seal tape).
- When you remove the two ends of a pipe, remove the lower end first.
- Use two pliers in removal and installation. One to hold the stable side, and the other to turn the side you remove to prevent twists.
- Make sure that the sleeves of flared connectors and tapers of hoses are free of dust and scratches.
- After you tighten the fittings, clean the joint and apply the maximum operation pressure 2 to 3 times to check oil leakage.

- (1) Grease
- (2) Force
- (3) Sharp Edge
- (4) Axial Force
- (5) Rotating Movement

- (A) External Cir-clip
- (B) Internal Cir-clip

WSM000001GEG0106US0



### 3. HANDLING PRECAUTIONS FOR ELECTRICAL PARTS AND WIRING

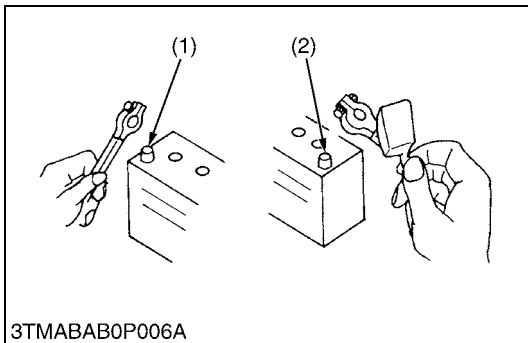

3TMABAB0P006A

To ensure safety and prevent damage to the machine and surrounding equipment, obey the following precautions in handling electrical parts and wiring.

■ **IMPORTANT**

- **Check electrical wiring for damage and loosened connection every year. To this end, educate the customer to do his or her own check and at the same time recommend the dealer to perform periodic check for a fee.**
- **Do not try to modify or remodel any electrical parts and wiring.**
- **When removing the battery cables, disconnect the negative cable first. When installing the battery cables, connect the positive cable first.**

(1) Negative Terminal

(2) Positive Terminal

WSM000001GEG0062US0

#### [1] WIRING

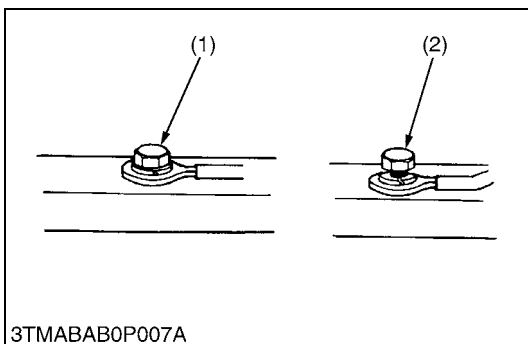

3TMABAB0P007A

- Securely tighten wiring terminals.

(1) Correct  
(Securely Tighten)

(2) Incorrect  
(Loosening Leads to damaged Contact)

WSM000001GEG0063US0

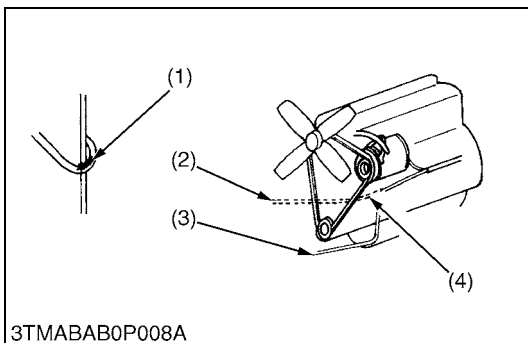

3TMABAB0P008A

- Do not let wiring contact dangerous part.

(1) Dangerous Part (Sharp Edge)  
(2) Wiring (Incorrect)

(3) Wiring (Correct)  
(4) Dangerous Part

WSM000001GEG0064US0

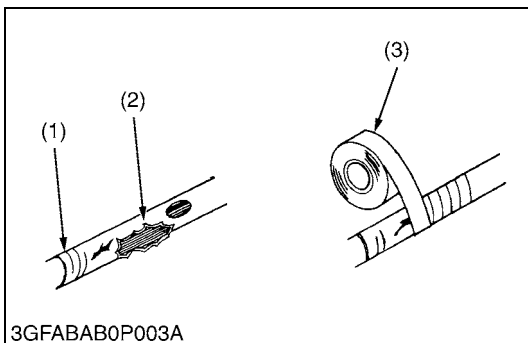

3GFABAB0P003A

- Repair or change torn or aged wiring immediately.

(1) Aged  
(2) Torn

(3) Insulating Vinyl Tape

WSM000001GEG0065US0

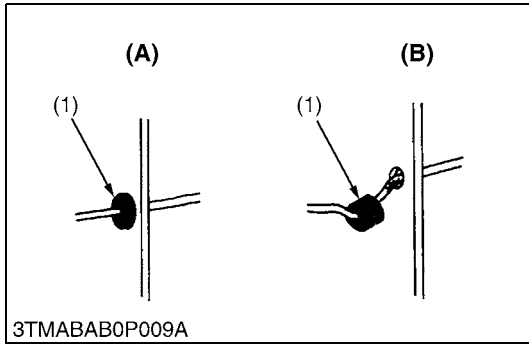

- Securely insert grommet.
- (1) Grommet (A) Correct  
(B) Incorrect

WSM000001GEG0066US0

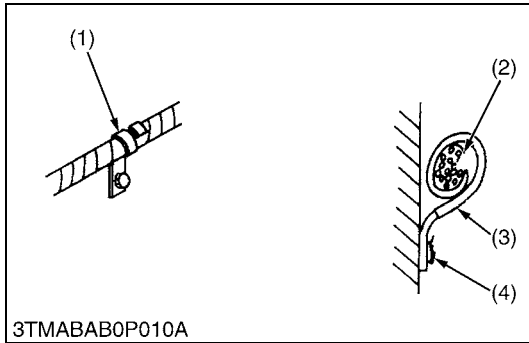

- Securely clamp, being careful not to damage wiring.
- (1) Clamp (Wind Clamp Spirally) (3) Clamp  
(2) Wire Harness (4) Welding Dent

WSM000001GEG0067US0

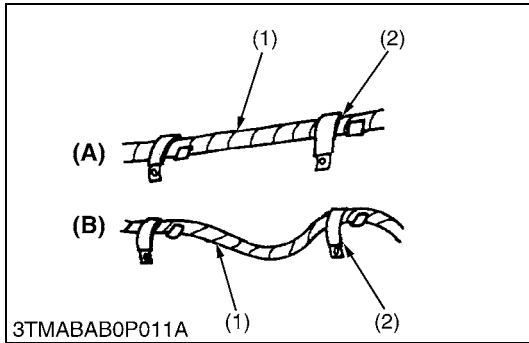

- Clamp wiring so that there is no twist, unnecessary sag, or excessive tension, except for movable part, where sag be required.
- (1) Wiring (A) Correct  
(2) Clamp (B) Incorrect

WSM000001GEG0068US0

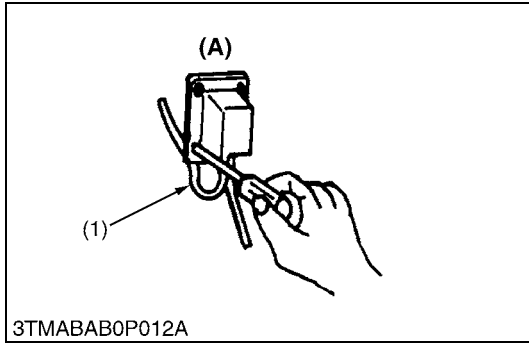

- In installing a part, be careful not to get wiring caught by it.
- (1) Wiring (A) Incorrect

WSM000001GEG0069US0

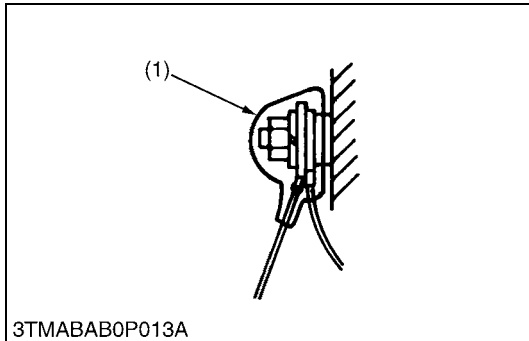

- After installing wiring, check protection of terminals and clamped condition of wiring.
- (1) Cover (Securely Install Cover)

WSM000001GEG0070US0

## [2] BATTERY

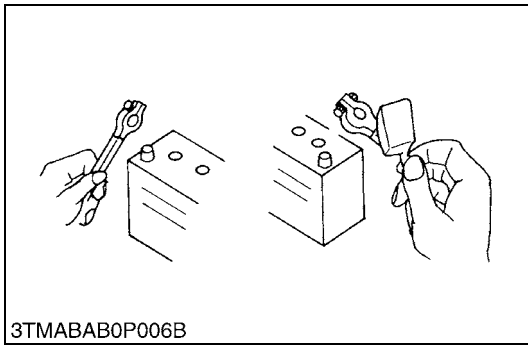

- Be careful not to confuse positive and negative terminal posts.
- When you remove battery cables, disconnect negative cable first. When you install battery cables, check for polarity and connect positive cable first.
- Do not install any battery with capacity other than is specified (Ah).
- After you connect cables to battery terminal posts, apply high temperature grease to them and securely install terminal covers on them.
- Do not allow dirt and dust to collect on battery.

### **⚠ DANGER**

To avoid serious injury or death:

- Be careful not to let battery liquid spill on your skin and clothes. If contaminated, wash it off with water immediately.
- Before you recharge the battery, remove it from the machine.
- Before you recharge, remove cell caps.
- Recharge in a well-ventilated place where there is no open flame nearby, as hydrogen gas and oxygen are formed.

WSM000001GEG0071US0

## [3] FUSE

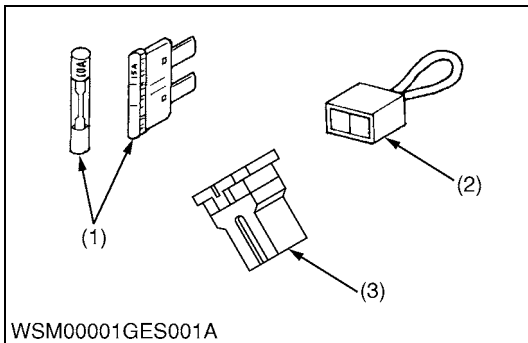

- Use fuses with specified capacity. Neither too large nor small capacity fuse is acceptable.
- Never use steel nor copper wire in place of fuse.
- Do not install working light, radio set, etc. on machine which is not provided with reserve power supply.
- Do not install accessories if fuse capacity of reserve power supply is exceeded.

- (1) Fuse (2) Fusible Link (3) Slow Blow Fuse

WSM000001GEG0072US0

## [4] CONNECTOR

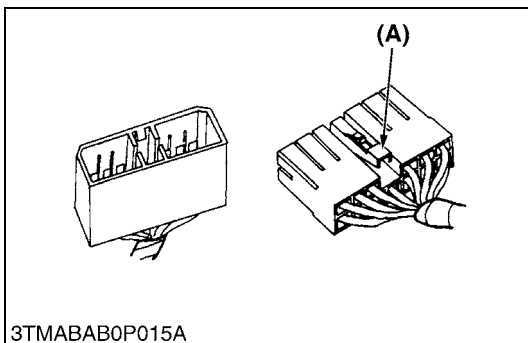

- For connector with lock, push lock to separate.

(A) Push

WSM000001GEG0073US0

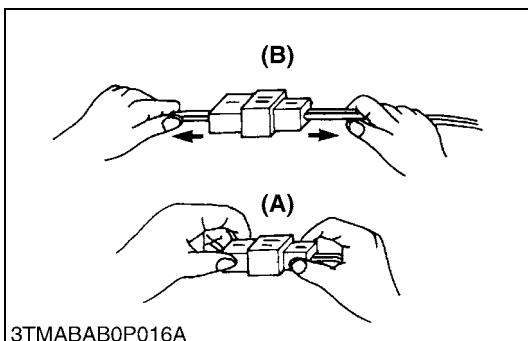

- In separating connectors, do not pull wire harnesses.
- Hold connector bodies to separate.

(A) Correct (B) Incorrect

WSM000001GEG0074US0

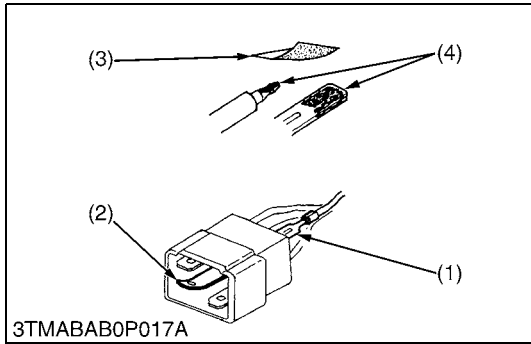

- Use sandpaper to remove rust from terminals.
- Repair deformed terminal. Make sure that there is no terminal being exposed or displaced.

- (1) Exposed Terminal
- (2) Deformed Terminal
- (3) Sandpaper
- (4) Rust

WSM000001GEG0075US0

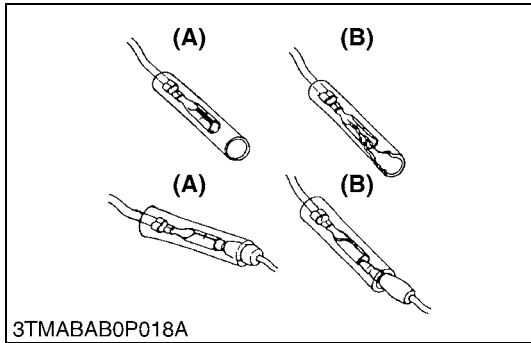

- Make sure that there is no female connector being too open.

- (A) Correct
- (B) Incorrect

WSM000001GEG0076US0

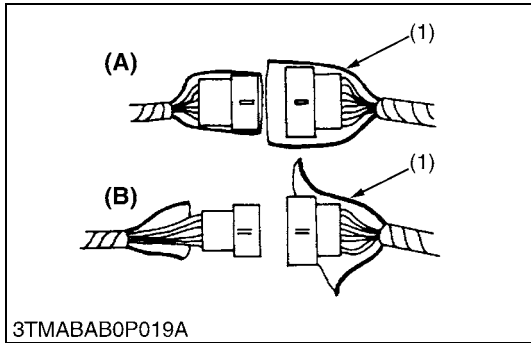

- Make sure that plastic cover is large enough to cover whole connector.

- (1) Cover
- (A) Correct
- (B) Incorrect

WSM000001GEG0077US0

## [5] HANDLING OF CIRCUIT TESTER

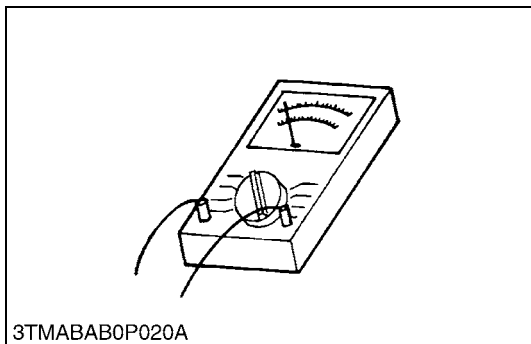

- Use tester correctly following manual provided with tester.
- Check for polarity and range.

WSM000001GEG0078US0

## [6] COLOR OF WIRING

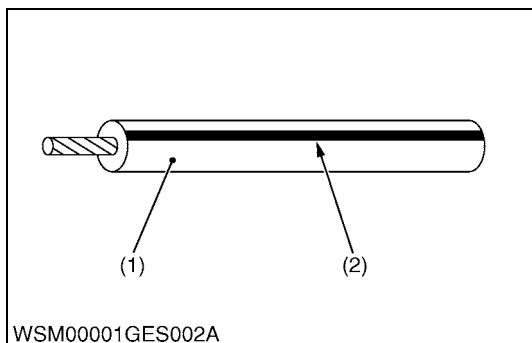

- Colors of wire are specified to the color codes.
- This symbol of "/" shows color with stripe (s).

**(An example)**

Red stripe on white color: W/R

Color of wiring	Color code
Black	B
Brown	Br
Green	G
Gray	Gy or Gr
Blue	L
Light Green	Lg
Orange	Or
Pink	P
Purple	Pu or V
Red	R
Sky Blue	Sb
White	W
Yellow	Y

(1) Wire Color

(2) Stripe

WSM000001GEG0079US0

# 4. LUBRICANTS, FUEL AND COOLANT

## [1] BX Tractor

### (1) Capacity Table

No.	Place	Capacity			Lubricants, fuel and coolant
		BX1870D	BX2370D	BX2670D	
1	Fuel	25.0 L 6.6 U.S.gals 5.5 Imp.gals			<ul style="list-style-type: none"> <li>No. 2-D diesel fuel</li> <li>No. 1-D diesel fuel if temperature is below -10 °C (14 °F)</li> </ul>
2	Cooling system with recovery tank	2.9 L 3.1 U.S.qts 2.6 Imp.qts	3.1 L 3.3 U.S.qts 2.7 Imp.qts	3.3 L 3.5 U.S.qts 2.9 Imp.qts	Fresh clean water anti-freeze
3	Engine crankcase*	2.9 L 3.1 U.S.qts 2.6 Imp.qts	3.1 L 3.3 U.S.qts 2.7 Imp.qts	3.5 L 3.7 U.S.qts 3.1 Imp.qts	<b>Engine oil</b> API Service Classification CF or higher <ul style="list-style-type: none"> <li>Below 0 °C (32 °F) SAE10W, SAE10W-30 or 15W-40</li> <li>0 to 25 °C (32 to 77 °F) SAE20, SAE10W-30 or 15W-40</li> <li>Above 25 °C (77 °F) SAE30, SAE10W-30 or 15W-40</li> </ul>
4	Transmission case	11.6 L 3.1 U.S.gals 2.6 Imp.gals			KUBOTA SUPER UDT fluid**
5	Front differential case	2.3 L 2.4 U.S.qts 2.0 Imp.qts	4.7 L 5.0 U.S.qts 4.1 Imp.qts		KUBOTA SUPER UDT fluid** or SAE80, SAE90 gear oil

Greasing				
No.	Place	No. of greasing point	Capacity	Type of grease
6	Battery terminal	2	Moderate amount	Multipurpose type Grease EP2 Grease (NLGI Grade No.2)
7	Speed control pedal	1	Until grease overflows	

\*: Oil amount when the oil level is at the upper level of the oil level gauge.

\*\* : The product name of KUBOTA genuine UDT fluid may be different from that in the Operator's Manual depending on countries or territories. Consult your local KUBOTA Dealer for further detail.

**■ IMPORTANT**

- To prevent serious damage to hydraulic systems, use only KUBOTA genuine fluid or its equivalent.

9Y1210855GEG0005US0

## (2) Engine Oil, Fuel and Transmission Oil

### [A] For North American Market

■ **NOTE**

**Engine Oil**

- Oil used in the engine should have an American Petroleum Institute (API) service classification and Proper SAE Engine Oil according to the ambient temperatures as shown above:
- Refer to the following table for the suitable API classification engine oil according to the engine type (with internal EGR, external EGR or non-EGR) and the fuel.

Fuel used	Engine oil classification (API classification)	
	Oil class of engines except external EGR	Oil class of engines with external EGR
Ultra Low Sulfur Fuel [< 0.0015 % (15 ppm)]	<b>CF, CF-4, CG-4, CH-4 or CI-4</b>	<b>CF or CI-4</b> (Class CF-4, CG-4 and CH-4 engine oils cannot be used on EGR type engines)

**EGR: Exhaust Gas Re-circulation**

- The CJ-4 engine oil is intended for DPF (Diesel Particulate Filter) type engines, and cannot be used on this tractor.

	except external EGR	with external EGR
Models	BX1870D, BX2370D and BX2670D	–

**Fuel**

- Cetane number of 45 is minimum. Cetane number greater than 50 is preferred, especially for temperatures below -20 °C (-4 °F) or elevations above 1500 m (5000 ft).
- Diesel fuels specified to EN 590 or ASTM D975 are recommended.
- No.2-D is a distillate fuel of lower volatility for engines in industrial and heavy mobile service. (SAE J313 JUN87)

**Transmission oil**

- KUBOTA Super UDT-2: For an enhanced ownership experience, we highly recommend Super UDT-2 to be used instead of standard hydraulic/transmission fluid.  
Super UDT-2 is a proprietary KUBOTA formulation that delivers superior performance and protection in all operating conditions.  
Regular UDT is also permitted for use in this machine.

- **Indicated capacities of water and oil are manufacturer's estimate.**

9Y1210855GEG0006US0

**[B] For Other Than North American Market**

■ **NOTE**

**Engine Oil**

- Oil used in the engine should have an American Petroleum Institute (API) service classification and Proper SAE Engine Oil according to the ambient temperatures as shown above:
- With the emission control now in effect, the CF-4 and CG-4 lubricating oils have been developed for use of a low sulfur fuel on on-road vehicle engines. When an off-road vehicle engine runs on a high-sulfur fuel, it is advisable to employ the "CF or better" lubricating oil with a high Total Base Number (TBN of 10 minimum).
- Refer to the following table for the suitable API classification engine oil according to the engine type (with internal EGR, external EGR or non-EGR) and the fuel (low-sulfur or high-sulfur fuel).

Fuel used	Engine oil classification (API classification)	
	Oil class of engines except external EGR	Oil class of engines with external EGR
High Sulfur Fuel [≥ 0.05 % (500 ppm)]	<b>CF</b> (If the "CF-4, CG-4, CH-4 or CI-4" lubricating oil is used with a high-sulfur fuel, change the lubricating oil at shorter intervals. (approximately half))	–
Low Sulfur Fuel [< 0.05 % (500 ppm)] or Ultra Low Sulfur Fuel [< 0.0015 % (15 ppm)]	<b>CF, CF-4, CG-4, CH-4 or CI-4</b>	<b>CF or CI-4</b> (Class CF-4, CG-4 and CH-4 engine oils cannot be used on EGR type engines)

**EGR: Exhaust Gas Re-circulation**

- The CJ-4 engine oil is intended for DPF (Diesel Particulate Filter) type engines, and cannot be used on this tractor.

	except external EGR	with external EGR
Models	–	–

**Fuel**

- Cetane number of 45 is minimum. Cetane number greater than 50 is preferred, especially for temperatures below –20 °C (–4 °F) or elevations above 1500 m.
- If diesel fuel with sulfur content greater than 0.5 % (5000 ppm) sulfur content is used, reduce the service interval for engine oil and filter by 50 %.
- NEVER use diesel fuel with sulfur content greater than 0.05 % (500 ppm) for EXTERNAL EGR type engine.
- DO NOT use diesel fuel with sulfur content greater than 1.0 % (10000 ppm).
- Diesel fuels specified to EN 590 or ASTM D975 are recommended.
- No.2-D is a distillate fuel of lower volatility for engines in industrial and heavy mobile service. (SAE J313 JUN87)

**Transmission oil**

- The oil used to lubricate the transmission is also used as hydraulic fluid. To ensure proper operation of the hydraulic system and to complete lubrication of the transmission, it is important that a multi-grade transmission fluid is used in this system. We recommend the use of **KUBOTA UDT** or **SUPER UDT fluid** for optimum protection and performance. (Consult your local KUBOTA Distributor for further detail.) Do not mix different brands together.

■ **Indicated capacities of water and oil are manufacturer's estimate.**

9Y1210855GEG0007US0



## [2] MOWER

### (1) Lubricants

No.	Place	Capacity		Lubricant
	Model	RCK60B-23BX RCK54-23BX RCK48-18BX RCK54D-26BX RCK60D-26BX	RCK54P-23BX RCK48P-18BX	
1	Gear Box	0.36 L 0.38 U.S.qts 0.32 Imp.qts	0.15 L 0.16 U.S.qts 0.13 Imp.qts	• SAE 90 gear oil (API Service GL-5 gear oil)

Greasing				
No.	Place	Capacity	Type of grease	
	Model		RCK60B-23BX RCK54-23BX RCK48-18BX RCK54P-23BX RCK48P-18BX	RCK54D-26BX RCK60D-26BX
2	Universal joint	Until grease overflows	SAE multi-purpose type grease NLGI-2 or NLGI-1 (GC-LB)	Multipurpose EP2 grease NLGI Grade No.2
3	Three spindle shafts			
4	Belt tension pulley			
5	Belt tension pivot			
6	Balance shaft (RCK60B-23BX only)			
7	Front and rear anti-scalp roller			

9Y1210855GEG0008US0

## [3] FRONT LOADER

### (1) Lubricants

To prevent serious damage to hydraulic system, use only specified fluid or its equivalent.







Place	Greasing	Lubricants
Grease fitting	Until grease overflows	Moly Ep Type grease

9Y1210855GEG0009US0

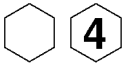
# 5. TIGHTENING TORQUES

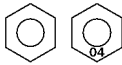
## [1] GENERAL USE SCREWS, BOLTS AND NUTS (TRACTOR AND MOWER)

Tighten screws, bolts and nuts whose tightening torques are not specified in this Workshop Manual according to the table below.

Indication on top of bolt	 No-grade or 4T						 7T						 9T		
Indication on top of nut	 No-grade or 4T												   6T		
Material of opponent part	Ordinariness			Aluminum			Ordinariness			Aluminum			Ordinariness		
Unit	N-m	kgf-m	lbf-ft	N-m	kgf-m	lbf-ft	N-m	kgf-m	lbf-ft	N-m	kgf-m	lbf-ft	N-m	kgf-m	lbf-ft
<b>M6</b>	7.9 to 9.3	0.80 to 0.95	5.8 to 6.8	7.9 to 8.8	0.80 to 0.90	5.8 to 6.5	9.81 to 11.2	1.00 to 1.15	7.24 to 8.31	7.9 to 8.8	0.80 to 0.90	5.8 to 6.5	12.3 to 14.2	1.25 to 1.45	9.05 to 10.4
<b>M8</b>	18 to 20	1.8 to 2.1	13 to 15	17 to 19	1.7 to 2.0	13 to 14	24 to 27	2.4 to 2.8	18 to 20	18 to 20	1.8 to 2.1	13 to 15	30 to 34	3.0 to 3.5	22 to 25
<b>M10</b>	40 to 45	4.0 to 4.6	29 to 33	32 to 34	3.2 to 3.5	24 to 25	48 to 55	4.9 to 5.7	36 to 41	40 to 44	4.0 to 4.5	29 to 32	61 to 70	6.2 to 7.2	45 to 52
<b>M12</b>	63 to 72	6.4 to 7.4	47 to 53	-	-	-	78 to 90	7.9 to 9.2	58 to 66	63 to 72	6.4 to 7.4	47 to 53	103 to 117	10.5 to 12.0	76.0 to 86.7
<b>M14</b>	108 to 125	11.0 to 12.8	79.6 to 92.5	-	-	-	124 to 147	12.6 to 15.0	91.2 to 108	-	-	-	167 to 196	17.0 to 20.0	123 to 144
<b>M16</b>	167 to 191	17.0 to 19.5	123 to 141	-	-	-	197 to 225	20.0 to 23.0	145 to 166	-	-	-	260 to 304	26.5 to 31.0	192 to 224
<b>M18</b>	246 to 284	25.0 to 29.0	181 to 209	-	-	-	275 to 318	28.0 to 32.5	203 to 235	-	-	-	344 to 402	35.0 to 41.0	254 to 296
<b>M20</b>	334 to 392	34.0 to 40.0	246 to 289	-	-	-	368 to 431	37.5 to 44.0	272 to 318	-	-	-	491 to 568	50.0 to 58.0	362 to 419

WSM000001GEG0001US0

## [2] GENERAL USE SCREWS, BOLTS AND NUTS (FRONT LOADER)

Tighten screws, bolts and nuts whose tightening torques are not specified in this Workshop Manual according to the table below.

Indication on top of bolt	⬡ 4 No-grade or 4T						⬡ 7 ⬡ 8.8 7T or Property class 8.8						⬡ 9 ⬡ 10.9 9T or Property class 10.9		
	Ordinariness			Aluminum			Ordinariness			Aluminum			Ordinariness		
Material of opponent part	Ordinariness			Aluminum			Ordinariness			Aluminum			Ordinariness		
Unit	N-m	kgf-m	lbf-ft	N-m	kgf-m	lbf-ft	N-m	kgf-m	lbf-ft	N-m	kgf-m	lbf-ft	N-m	kgf-m	lbf-ft
<b>M6</b> (6 mm, 0.24 in.)	7.9 to 9.3	0.80 to 0.95	5.8 to 6.8	7.9 to 8.8	0.80 to 0.90	5.8 to 6.5	9.81 to 11.2	1.00 to 1.15	7.24 to 8.31	7.9 to 8.8	0.80 to 0.90	5.8 to 6.5	12.3 to 14.2	1.25 to 1.45	9.05 to 10.4
<b>M8</b> (8 mm, 0.31 in.)	18 to 20	1.8 to 2.1	13 to 15	17 to 19	1.7 to 2.0	13 to 14	24 to 27	2.4 to 2.8	18 to 20	18 to 20	1.8 to 2.1	13 to 15	30 to 34	3.0 to 3.5	22 to 25
<b>M10</b> (10 mm, 0.39 in.)	40 to 45	4.0 to 4.6	29 to 33	32 to 34	3.2 to 3.5	24 to 25	48 to 55	4.9 to 5.7	36 to 41	40 to 44	4.0 to 4.5	29 to 32	61 to 70	6.2 to 7.2	45 to 52
<b>M12</b> (12 mm, 0.47 in.)	63 to 72	6.4 to 7.4	47 to 53	-	-	-	78 to 90	7.9 to 9.2	58 to 66	63 to 72	6.4 to 7.4	47 to 53	103 to 117	10.5 to 12.0	76.0 to 86.7
<b>M14</b> (14 mm, 0.55 in.)	108 to 125	11.0 to 12.8	79.6 to 92.5	-	-	-	124 to 147	12.6 to 15.0	91.2 to 108	-	-	-	167 to 196	17.0 to 20.0	123 to 144
<b>M16</b> (16 mm, 0.63 in.)	167 to 191	17.0 to 19.5	123 to 141	-	-	-	197 to 225	20.0 to 23.0	145 to 166	-	-	-	260 to 304	26.5 to 31.0	192 to 224
<b>M18</b> (18 mm, 0.71 in.)	246 to 284	25.0 to 29.0	181 to 209	-	-	-	275 to 318	28.0 to 32.5	203 to 235	-	-	-	344 to 402	35.0 to 41.0	254 to 296
<b>M20</b> (20 mm, 0.79 in.)	334 to 392	34.0 to 40.0	246 to 289	-	-	-	368 to 431	37.5 to 44.0	272 to 318	-	-	-	491 to 568	50.0 to 58.0	362 to 419

WSM000001GEG0006US0

## [3] STUD BOLTS

Material of opponent part	Ordinariness			Aluminum		
	N-m	kgf-m	lbf-ft	N-m	kgf-m	lbf-ft
<b>M8</b>	12 to 15	1.2 to 1.6	8.7 to 11	8.9 to 11	0.90 to 1.2	6.5 to 8.6
<b>M10</b>	25 to 31	2.5 to 3.2	18 to 23	20 to 25	2.0 to 2.6	15 to 18
<b>M12</b>	30 to 49	3.0 to 5.0	22 to 36	31	3.2	23
<b>M14</b>	62 to 73	6.3 to 7.5	46 to 54	-	-	-
<b>M16</b>	98.1 to 112	10.0 to 11.5	72.4 to 83.1	-	-	-
<b>M18</b>	172 to 201	17.5 to 20.5	127 to 148	-	-	-

WSM000001GEG0002US0

### [4] METRIC SCREWS, BOLTS AND NUTS

Grade	8.8 Property class 8.8			10.9 Property class 10.9		
	Unit	N-m	kgf-m	lbf-ft	N-m	kgf-m
M8	24 to 27	2.4 to 2.8	18 to 20	30 to 34	3.0 to 3.5	22 to 25
M10	48 to 55	4.9 to 5.7	36 to 41	61 to 70	6.2 to 7.2	45 to 52
M12	78 to 90	7.9 to 9.2	58 to 66	103 to 117	10.5 to 12.0	76.0 to 86.7
M14	124 to 147	12.6 to 15.0	91.2 to 108	167 to 196	17.0 to 20.0	123 to 144
M16	197 to 225	20.0 to 23.0	145 to 166	260 to 304	26.5 to 31.0	192 to 224



WSM000001GEG0003US0

### [5] AMERICAN STANDARD SCREWS, BOLTS AND NUTS WITH UNC OR UNF THREADS

Grade	SAE GR.5			SAE GR.8		
	Unit	N-m	kgf-m	lbf-ft	N-m	kgf-m
1/4	11.7 to 15.7	1.20 to 1.60	8.63 to 11.5	16.3 to 19.7	1.67 to 2.00	12.0 to 14.6
5/16	23.1 to 27.7	2.36 to 2.82	17.0 to 20.5	33 to 39	3.4 to 3.9	25 to 28
3/8	48 to 56	4.9 to 5.7	36 to 41	61 to 73	6.3 to 7.4	45 to 53
1/2	110 to 130	11.3 to 13.2	81.2 to 95.8	150 to 178	15.3 to 18.1	111 to 131
9/16	150 to 178	15.3 to 18.1	111 to 131	217 to 260	22.2 to 26.5	160 to 191
5/8	204 to 244	20.8 to 24.8	151 to 179	299 to 357	30.5 to 36.4	221 to 263

WSM000001GEG0008US0

### [6] PLUGS

Shape	Size	Material of opponent part					
		Ordinariness			Aluminum		
		N-m	kgf-m	lbf-ft	N-m	kgf-m	lbf-ft
Tapered screw 	R1/8	13 to 21	1.3 to 2.2	9.4 to 15	13 to 19	1.3 to 2.0	9.4 to 14
	R1/4	25 to 44	2.5 to 4.5	18 to 32	25 to 34	2.5 to 3.5	18 to 25
	R3/8	49 to 88	5.0 to 9.0	37 to 65	49 to 58	5.0 to 6.0	37 to 43
	R1/2	58.9 to 107	6.00 to 11.0	43.4 to 79.5	59 to 78	6.0 to 8.0	44 to 57
Straight screw 	G1/4	25 to 34	2.5 to 3.5	18 to 25	-	-	-
	G3/8	62 to 82	6.3 to 8.4	46 to 60	-	-	-
	G1/2	49 to 88	5.0 to 9.0	37 to 65	-	-	-

WSM000001GEG0005US0

# [7] HYDRAULIC FITTINGS

## (1) Adaptors, Elbows and Others

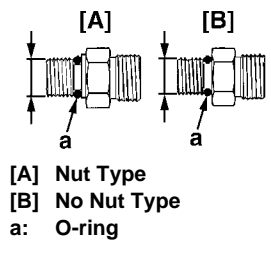
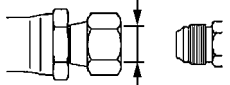
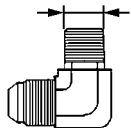
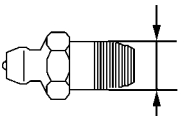
Item	Shape	Thread size	Tightening torque		
			N·m	kgf·m	lbf·ft
Adjustable elbow, Adapter (O-ring port) (UNF)	 <p>[A] Nut Type [B] No Nut Type a: O-ring</p>	7/16	18.0 to 20.0	1.84 to 2.03	13.3 to 14.7
		9/16	37.0 to 44.0	3.78 to 4.48	27.3 to 32.4
		3/4	48.0 to 54.0	4.90 to 5.50	35.4 to 39.8
		7/8	77.0 to 85.0	7.86 to 8.66	56.8 to 62.6
Hose fitting, Flare nut (UNF)		9/16	22.0 to 25.0	2.2 to 2.5	16.0 to 19.0
		3/4	36.0 to 40.0	3.67 to 4.07	26.6 to 29.5
		7/8	43.0 to 50.0	4.39 to 5.09	31.8 to 36.8
		1 1/16	107 to 119	11.0 to 12.1	79.0 to 87.7
Adapter (NPT)		1/4	30.0 to 50.0	3.06 to 5.09	22.2 to 36.8
		3/8	39.0 to 60.0	3.98 to 6.11	28.8 to 44.2
		1/2	49.0 to 58.0	5.00 to 5.91	36.2 to 42.7
Grease Fitting		1/8	4.1 to 6.7	0.42 to 0.68	3.1 to 4.9
		1/4	4.1 to 6.7	0.42 to 0.68	3.1 to 4.9

■ NOTE

- When connecting a hose with flare nut, after tightening the nut with specified torque, return it approximately 45 degrees (0.79 rad) and re-tighten it to specified torque.

WSM000001GEG0010US0

# 6. MAINTENANCE CHECK LIST

## [1] BX TRACTOR

No.	Item		Service Interval								Since then	Refer- ence page	important		
			50	100	150	200	250	300	350	400					450
1	Engine oil	Change	★			☆				☆		every 200 Hr	G-21	*1	
2	Engine oil filter	Replace	★			☆				☆		every 200 Hr	G-21	*1	
3	Transmission oil filter	Replace	★			☆				☆		every 200 Hr	G-22	*1	
4	Transmission fluid	Change								☆		every 400 Hr	G-32		
5	Transmission strainer	Clean								☆		every 400 Hr	G-32		
6	Front axle case oil	Change								☆		every 400 Hr	G-33		
7	Front axle pivot	Adjust								☆		every 400 Hr	G-33		
8	Engine start system	Check	☆	☆	☆	☆	☆	☆	☆	☆	☆	every 50 Hr	G-23		
9	OPC system	Check	☆	☆	☆	☆	☆	☆	☆	☆	☆	every 50 Hr	G-24		
10	Greasing	–	☆	☆	☆	☆	☆	☆	☆	☆	☆	every 50 Hr	G-24		
11	Wheel bolt torque	Check	☆	☆	☆	☆	☆	☆	☆	☆	☆	every 50 Hr	G-25		
12	Battery condition	Check		☆		☆		☆		☆		every 100 Hr	G-26	*7	
13	Air cleaner element	Clean		☆		☆		☆		☆		every 100 Hr	G-28	*2	
		Replace										every 1000 Hr or 1 year	G-34	*3	@
14	Fuel filter element	Check		☆		☆		☆		☆		every 100 Hr	G-29		@
		Replace										every 400 Hr	G-34	*6	@
15	Fan belt	Adjust		☆		☆		☆		☆		every 100 Hr	G-29		
16	HST neutral spring	Adjust		☆		☆		☆		☆		every 100 Hr	G-29	*6	
17	Brake pedal	Adjust		☆		☆		☆		☆		every 100 Hr	G-30		
18	Radiator hose and clamp	Check										every 1 year	G-38	*4	
		Replace										every 4 years	G-39	*6	
19	Power steering oil line	Check										every 1 year	G-38	*4	
		Replace										every 4 years	G-39	*6	
20	Fuel line	Check										every 1 year	G-38	*4	@
		Replace										every 4 years	G-40	*6	@
21	Intake air line	Check										every 1 year	G-39	*4	@
		Replace										every 4 years	G-40	*6	@
22	Engine breather hose	Check										every 1 year	G-39	*4	
		Replace										every 4 years	G-40	*6	
23	Toe-in	Adjust				☆				☆		every 200 Hr	G-31		
24	Engine valve clearance	Adjust										every 800 Hr	1-S18	*6	
25	Fuel injection nozzle injection pressure	Check										every 1500 Hr	1-S24	*6	@
26	Injection pump	Check										every 3000 Hr	1-S23	*6	@
27	Cooling system	Flush										every 2000 Hr or 2 years	G-35	*5	
28	Coolant	Change										every 2000 Hr or 2 years	G-35	*5	
29	Fuel system	Bleed										Service as required	G-40		
30	Fuse	Replace											G-41		
31	Light bulb	Replace											G-41		

(To be continued)

**(Continued)**

■ **IMPORTANT**

- The jobs indicated by ★ must be done after the first 50 hours of operation.
  - \*1 The initial 50 hours should not be a replacement cycle.
  - \*2 Air cleaner should be cleaned more often in dusty conditions than in normal conditions.
  - \*3 Every 1,000 hours or every 1 year whichever comes faster.
  - \*4 Replace if any deterioration (crack, hardening, scar, or deformation) or damage occurred.
  - \*5 Every 2,000 hours or every 2 years whichever comes faster.
  - \*6 Consult your local KUBOTA Dealer for this service.
  - \*7 When the battery is used for less than 100 hours per year, check the battery condition by reading the indicator annually.
- The items listed above (@ marked) are registered as emission related critical parts by KUBOTA in the U.S.EPA nonroad emission regulation. As the engine owner, you are responsible for the performance of the required maintenance on the engine according to the above instruction.  
Please see Warranty Statement in detail.

9Y1210855GEG0010US0

**[2] MOWER**

To keep the mower working in good condition as well as to avoid any accident and trouble, do periodic inspection and maintenance. Check the following points before use.

No.	Check Point	Used hours (Change or check every interval)					Refer- ence page
		Daily check	50 hrs	150 hrs	1 year	4 years	
1	Oil leakage check	☆					–
2	Make sure blade bolts are tight	☆					G-42
3	Blade and belt wear check	☆					G-42
4	All hardware check	☆					–
5	Make sure all pins are in place	☆					–
6	Mower deck cleaning	☆					–
7	Greasing • Universal joint • Three spindle shafts • Belt tension pulley • Belt tension pivot • Front and Rear anti-scalp rollers • Balance Shaft	☆					G-44, G-45
8	Gear box oil check	☆					G-43
9	Gear box oil change		★	☆			G-46
10	Gear box oil seal check				☆*1		–
11	Gear box oil seal replace					☆	7-S22

■ **IMPORTANT**

- The jobs indicated by ★ must be done the first time at 50 hrs.
- \*1: Replace if any deterioration (crack, hardening, scar, or deformation) or damage occurred.

9Y1210855GEG0098US0

### [3] FRONT LOADER

To keep the machine working in good condition as well as to avoid any accident and trouble, do the periodic inspection and maintenance. Check the following points before use.

Service Interval	Check Points	Reference page
Daily (Each use)	Check the transmission fluid level	G-48
	Check the hydraulic hoses	G-48
Every 10 hours	Grease all grease fitting	G-48
	Lubricate joints of control lever linkage	G-48

9Y1210855GEG0012US0



## 7. CHECK AND MAINTENANCE

### [1] BX TRACTOR



To avoid personal injury or death:

Take the following precautions when checking the tractor.

- Park the machine on firm and level ground.
- Set the parking brake.
- Lower the implement to the ground.
- All residual pressure of the hydraulic system released.
- Stop the engine and remove the key.

9Y1210855GEG0013US0

#### (1) Daily Check

For your own safety and maximum service life of the machine, make a thorough daily inspection before operating the machine to start the engine.

##### ■ Walk Around Inspection

Look around the under the tractor for such items as loose bolts, trash build-up, oil or coolant leaks, broken or worn parts.

9Y1210855GEG0014US0

##### Checking

1. Check and refueling.
2. Check the engine oil level.
3. Check the transmission fluid level.
4. Check the coolant level.
5. Clean panel and radiator screen.
6. Check the brake pedal.
7. Check the gauge, the meters and Easy Checker™.
8. Check the head light, the hazard lamp etc..
9. Check and clean the electrical wiring and the battery cables.
10. Check the seat belt and ROPS.
11. Check the movable parts.

9Y1210855GEG0015US0

## (2) Check Points of Initial 50 Hours

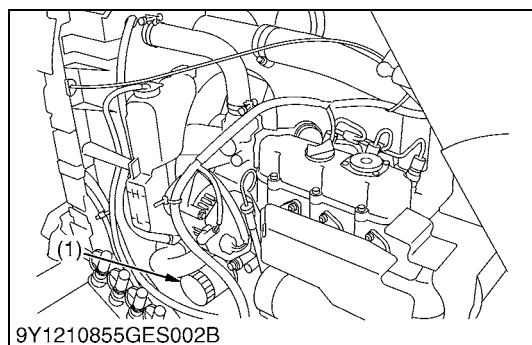
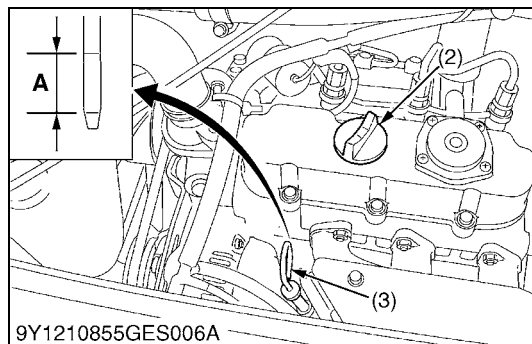
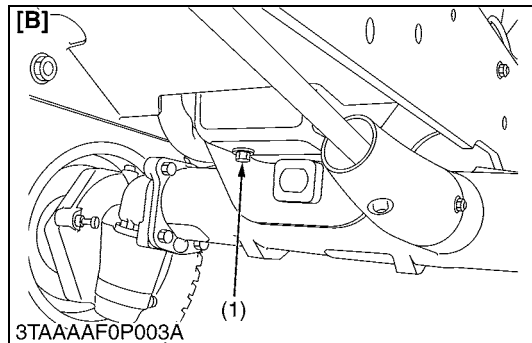
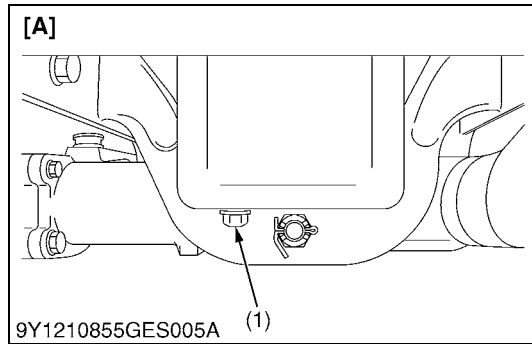

### Changing Engine Oil

#### ⚠ CAUTION

To avoid personal injury:

- Be sure to stop the engine and remove the key before changing the oil.
  - Allow engine to cool down sufficiently, oil can be hot and can burn.
1. To drain the used oil, remove the drain plug at the bottom of the engine and drain the oil completely into the oil pan. All the used oil can be drained out easily when the engine is still warm.
  2. After draining reinstall the drain plug.
  3. Fill with the new oil up to the upper notch on the dipstick.
  4. Properly dispose of used oil.

Engine oil	Capacity	BX1870D	2.9 L 3.1 U.S.qts 2.6 Imp.qts
		BX2370D	3.1 L 3.3 U.S.qts 2.7 Imp.qts
		BX2670D	3.5 L 3.7 U.S.qts 3.1 Imp.qts

- (1) Drain Plug
- (2) Oil Inlet
- (3) Dipstick

**A:** Oil level is acceptable within this range.

[A] BX1870D

[B] BX2370D and BX2670D

9Y1210855GEG0016US0

### Replacing Engine Oil Filter

#### ⚠ CAUTION

- Be sure to stop the engine before changing oil filter cartridge.
  - Allow engine to cool down sufficiently, oil can be hot and can burn.
1. Remove the oil filter.
  2. Put a film of clean engine oil on the rubber seal of the new filter.
  3. Tighten the filter quickly until it contacts the mounting surface. Tighten filter by hand an additional 1/2 turn only.
  4. After the new filter has been replaced, the engine oil normally decrease a little. Make sure that the engine oil does not leak through the seal and be sure to check the oil level on the dipstick. Then, fill the engine oil up to the specified level.
  5. Properly dispose of used oil.

#### ■ IMPORTANT

- To prevent serious damage to the engine, use only a KUBOTA genuine filter.

- (1) Engine Oil Filter Cartridge

9Y1210855GEG0017US0

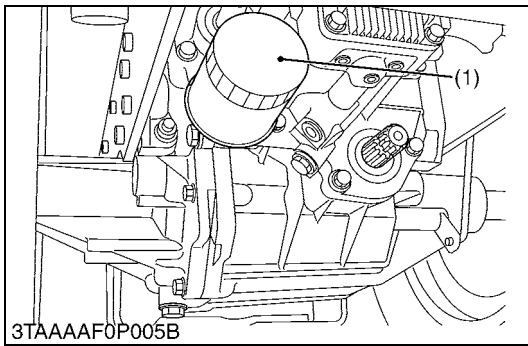

## Replacing Transmission Oil Filter

### CAUTION

- **Allow engine to cool down sufficiently, oil can be hot and can burn.**
1. Remove the oil filter.
  2. Put a film of clean transmission oil on the rubber seal of the new filter.
  3. Tighten the filter quickly until it contacts the mounting surface. Tighten filter by hand an additional 1/2 turn only.
  4. After the new filter has been replaced, the transmission fluid level will decrease a little. Make sure that the transmission fluid does not leak through the seal, and check the fluid level. Top off if necessary.
  5. Properly dispose of used oil.

### ■ IMPORTANT

- **To prevent serious damage to the hydraulic system, use only a KUBOTA genuine filter.**

(1) Transmission Oil Filter

9Y1210855GEG0018US0

### (3) Check Points of Every 50 Hours

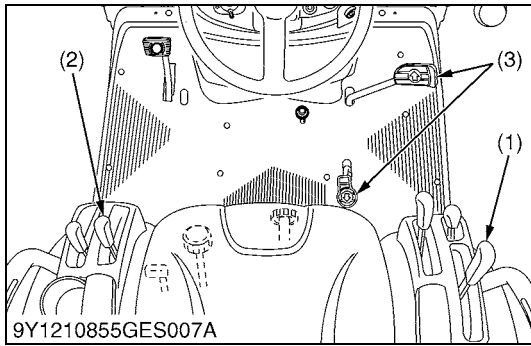

#### Checking Engine Start System

#### **! WARNING**

To avoid personal injury or death:

- Do not allow anyone near the tractor while testing.
- If the tractor does not pass the test do not operate the tractor.

#### ■ Preparation before testing.

1. Sit on the operator's seat.
2. Set the parking brake and stop the engine.
3. Shift the range gear shift lever (1) to "NEUTRAL" position.
4. Check the speed control pedal "NEUTRAL" position.
5. Shift the PTO clutch control lever (2) to "OFF" position.

#### ■ Test 1: Switch for the speed control pedal

1. Make sure that the range gear shift lever (1) is set in "NEUTRAL" position.
2. Depress the speed control pedal (3).
3. Turn the key to "START" position.
4. The engine must not crank.

#### ■ Test 2: Switch for the PTO clutch lever

1. Make sure that the range gear shift lever (1) is set in "NEUTRAL" position.
2. Make sure that the speed control pedal (3) is set in "NEUTRAL" position.
3. Shift the PTO clutch control lever (2) to "ON" position.
4. Turn the key to "START" position.
5. The engine must not crank.

- (1) Range Gear Shift Lever  
 (2) PTO Clutch Control Lever

- (3) Speed Control Pedal

9Y1210855GEG0020US0

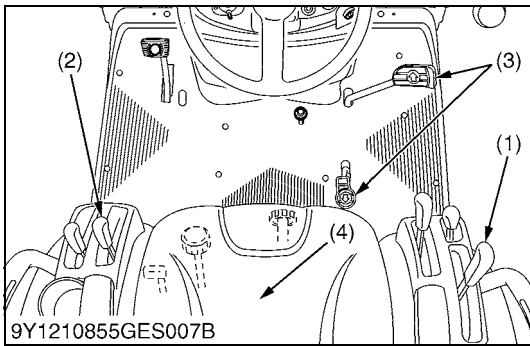

**Checking OPC System**

**⚠ WARNING**

To avoid personal injury or death:

- Do not allow anyone near the tractor while testing.
- If the tractor does not pass the test do not operate the tractor.

■ **Preparation before testing.**

1. Sit on the operator's seat.
2. Set the parking brake and stop the engine.
3. Shift the range gear shift lever (1) to "NEUTRAL" position.
4. Check the speed control pedal "NEUTRAL" position.
5. Shift the PTO clutch control lever (2) to "OFF" position.

■ **Test 1: Switch for the operator's seat and speed control pedal**

1. Start the engine.
2. Depress the speed control pedal (3).
3. Stand up. (Do not get off the machine.)
4. The engine must shut off after approximately 1 second.

■ **Test 2: Switches for the operator's seat and the PTO clutch lever**

1. Start the engine.
2. Engage the PTO clutch control lever (2).
3. Stand up. (Do not get off the machine.)
4. The engine must shut off after approximately 1 second.

- |                              |                         |
|------------------------------|-------------------------|
| (1) Range Gear Shift Lever   | (3) Speed Control Pedal |
| (2) PTO Clutch Control Lever | (4) Operator's Seat     |

9Y1210855GEG0021US0

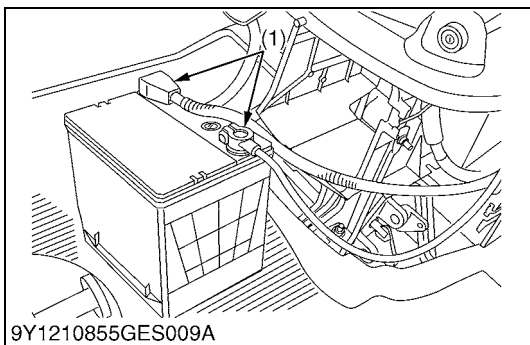

**Greasing**

1. Apply a small amount of multipurpose grease to the following points.

- |                      |                         |
|----------------------|-------------------------|
| (1) Battery Terminal | (2) Speed Control Pedal |
|----------------------|-------------------------|

9Y1210855GEG0022US0

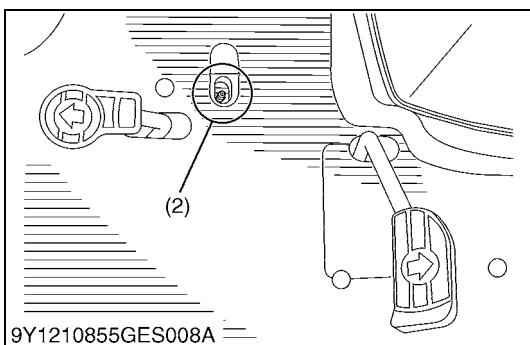

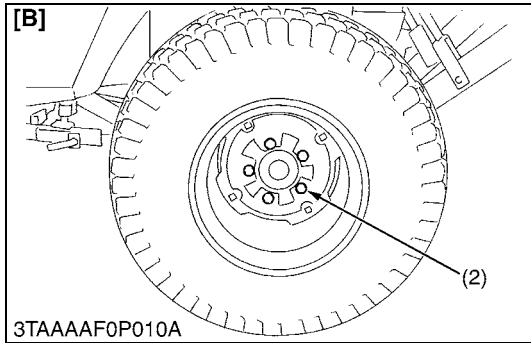
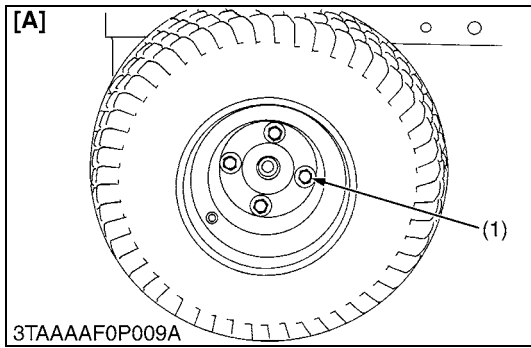

### Checking Wheel Mounting Screws Tightening Torque

**⚠ CAUTION**

- Never operate tractor with a loose rim, wheel, or axle.
  - Any time screws are loosened, retighten to specified torque.
  - Check all screws frequently and keep them tight.
1. Check wheel screws regularly especially when new. If there are loosened, tighten as follows.

Tightening torque	Front wheel mounting screws	149.2 to 179.0 N·m 15.2 to 18.3 kgf·m 110 to 132 lbf·ft
	Rear wheel mounting screws	108.5 to 130.2 N·m 11.1 to 13.3 kgf·m 80 to 96 lbf·ft

- (1) Front Wheel Mounting Screw      **[A] Front**  
 (2) Rear Wheel Mounting Screw      **[B] Rear**

9Y1210855GEG0023US0

## (4) Check Points of Every 100 Hours

### Checking Battery Condition

#### **DANGER**

To avoid the possibility of battery explosion:

For the refillable type battery, follow the instructions below.

- Do not use or charge the refillable type battery if the fluid level is below the LOWER (lower limit level) mark. Otherwise, the battery component parts may prematurely deteriorate, which may shorten the battery's service life or cause an explosion. Check the fluid level regularly and add distilled water as required so that the fluid level is between the UPPER and LOWER levels.

#### **WARNING**

To avoid personal injury or death:

- Never remove the battery cap while the engine is running.
- Keep electrolyte away from eyes, hands and clothes. If you are spattered with it, wash it away completely with water immediately and get medical attention.
- Keep open sparks and flames away from the battery at all times. Hydrogen gas mixed with oxygen becomes very explosive.
- Wear eye protection and rubber gloves when working around battery.

#### **■ IMPORTANT**

- Mishandling the battery shortens the service life and adds to maintenance costs.
- The original battery is maintenance free type battery, but need some servicing.

If the battery is weak, the engine will be difficult to start and the lights will be dim. It is important to check the battery periodically.

- When exchanging an old battery for new one, use battery of equal specification in table below.

Tractor Type	Battery Type	Volts (V)	Reserve Capacity (min.)	Cold Cranking Amps	Normal Charging Rate (A)
BX1870D	426RMF	12	55	450	6.5
BX2370D BX2670D	526RFM	12	80	540	6.5

(For non-accessible maintenance-free type batteries.) Maintenance-free, non-accessible batteries are designed to eliminate the need to add water. Yet the volume of electrolyte above plates may eventually become depleted due to abnormal conditions such as high heat or improper regulator setting. Use a voltmeter to check the state of charge. (See reference chart below to determine if charging is necessary.)

Battery voltage	Reference state of charge
12.6	100 % (Full charge)
12.4	75 %
12.2	50 %
12.0	25 %
11.8	0 %

(To be continued)

(Continued)

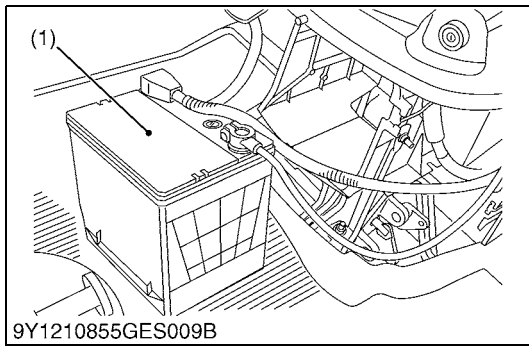

■ **Battery Charging**

**CAUTION**

- When the battery is being activated, hydrogen and oxygen gases in the battery are extremely explosive. Keep open sparks and flames away from the battery at all times, especially when charging the battery.
- When disconnecting the cable from the battery, start with the negative terminal first. When connecting the cable to the battery, start with the positive terminal first.
- Never check battery charge by placing a metal object across the posts.

**Use a voltmeter or hydrometer.**

1. To slow charge the battery, connect the battery positive terminal to the charger positive terminal and the negative to the negative, then charge for at least 1 hour at 6.5 amperes.
2. A boost charge is only for emergencies. It will partially charges the battery at a high rate and in a short time. When using a boost-charged battery, it is necessary to recharge the battery as early as possible. Failure to do this will shorten the battery's service life.
3. When the specific gravity of electrolyte become between 1.27 and 1.29 charge has completed.

■ **Battery for storage**

1. When storing the tractor for a long period, remove the battery from tractor, adjust the electrolyte to the proper level and store in a dry place out of direct sunlight.
2. The battery self-discharges while it is stored. Recharge it once every three months in hot seasons and once every six months in cold seasons.

(1) Battery

9Y1210855GEG0024US0



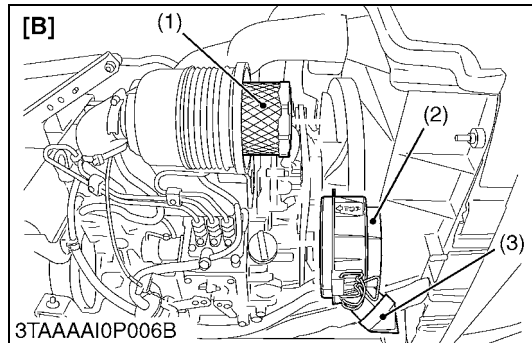
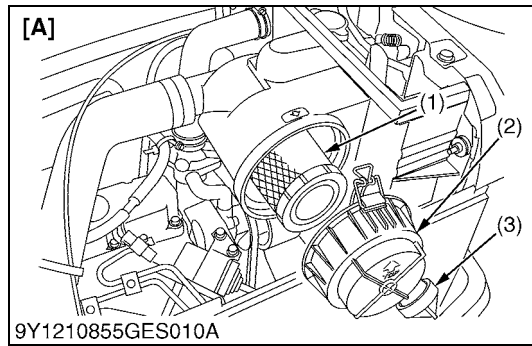

### Cleaning Air Cleaner Element

**⚠ CAUTION**

- **Be sure to stop the engine and remove the key before cleaning air cleaner element.**

1. Remove the air cleaner cover (2) and the element (1).
  - Undo the hook.
  - Turn the cover clockwise and detach it.
2. Clean the element:
  - When dry dust adheres to the element, blow compressed air from the inside, turning the element. Pressure of compressed air must be under 205 kPa (2.1 kgf/cm<sup>2</sup>, 30 psi).
  - When carbon or oil adheres to the element, soak the element in detergent for 15 minutes then wash it several times in water, rinse with clean water and dry it naturally. After element is fully dried, inspect inside of the element with a light and check if it is damaged or not. (Referring to the instructions on the label attached to the case.)
3. Replace air cleaner element:  
Every 1000 hours or every 1 year whichever comes first.

■ **NOTE**

- **Check to see if the evacuator valve is blocked with dust.**

■ **IMPORTANT**

- **The air cleaner uses a dry element, never apply oil.**
- **Do not run the engine with filter element removed.**
- **Align the arrow marks when reinstalling the cover. If the cover is improperly fitted, dust passes by the baffle and directly adheres to the element.**

■ **Evacuator Valve**

Open the evacuator valve once a week under ordinary conditions or daily when used in a dusty place to get rid of large particles of dust and dirt.

- (1) Element
- (2) Cover
- (3) Evacuator Valve

[A] **BX1870D and BX2370**

[B] **BX2670D**

9Y1210855GEG0025US0

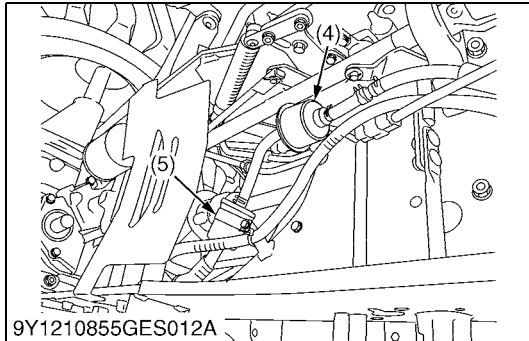
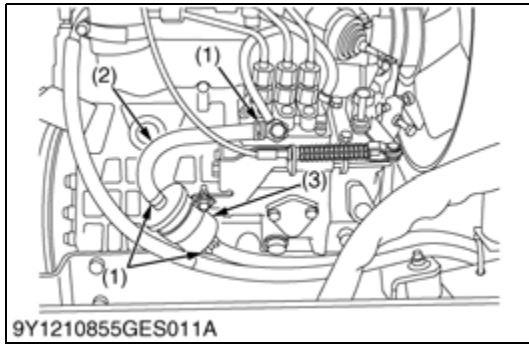

**Checking Fuel Line and Fuel Filter**

**⚠ CAUTION**

- Stop the engine and remove the key before checking fuel lines and fuel filter.
- Check the fuel lines periodically. The fuel lines are subject to wear and aging. Fuel may leak out onto the running engine, causing a fire.

The fuel line connections should be checked annually or every 100 service hours, whichever occurs first.

1. The fuel line is made of rubber and ages regardless of service period.
2. After inspection, if the fuel line and clamps are found damaged or deteriorated, replace them.
3. Check fuel filter, if it is clogged by debris or contaminated by water, replace it.

**■ IMPORTANT**

- When the fuel line is disconnected for maintenance or repair, plug both ends of the fuel line with a clean plug of suitable size to prevent dust and dirt from entering. Particular care must be taken not to admit dust and dirt into the fuel system. Entrance of dust and dirt causes malfunction of the fuel pump.

**■ NOTE**

- If the fuel line is removed, be sure to properly bleed the fuel system (see "Bleeding Fuel System" in service as required).

- |                 |                 |
|-----------------|-----------------|
| (1) Pipe Clamp  | (4) Fuel Pump   |
| (2) Fuel Line   | (5) Fuel Filter |
| (3) Fuel Filter |                 |

9Y1210855GEG0026US0

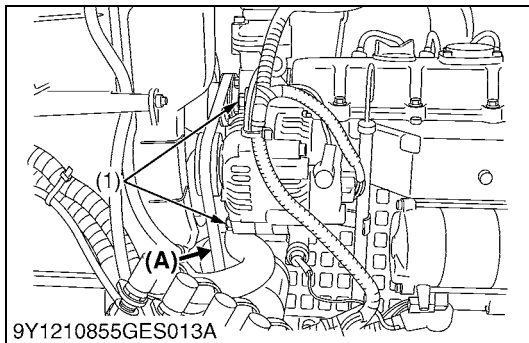

**Adjusting Fan Belt Tension**

**⚠ CAUTION**

- Be sure to stop engine and remove the key before checking belt tension.

1. Stop the engine and remove the key.
2. Apply moderate thumb pressure to belt between pulleys.
3. If tension is incorrect, loosen the alternator mounting bolts and using a lever placed between the alternator and the engine block, pull the alternator out until the deflection of the belt falls within acceptable limits.
4. Replace fan belt if it is damaged.

Fan belt tension	Factory specification	A deflection of between 7 to 9 mm (0.28 to 0.34 in.) when the belt is pressed in the middle of the span.
------------------	-----------------------	--

- |                   |                                    |
|-------------------|------------------------------------|
| (1) Mounting Bolt | <b>(A) Check the belt tension.</b> |
|-------------------|------------------------------------|

9Y1210855GEG0027US0

**Adjusting HST Neutral Spring (for Dynamic Braking)**

1. See page 2-S11.

9Y1210855GEG0028US0

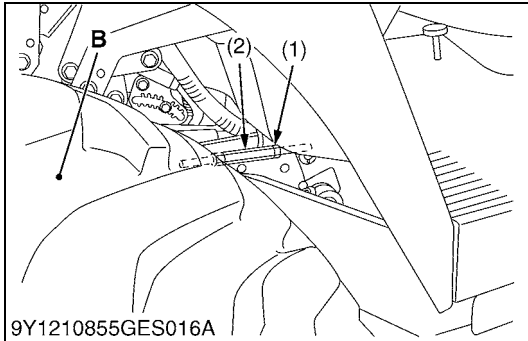
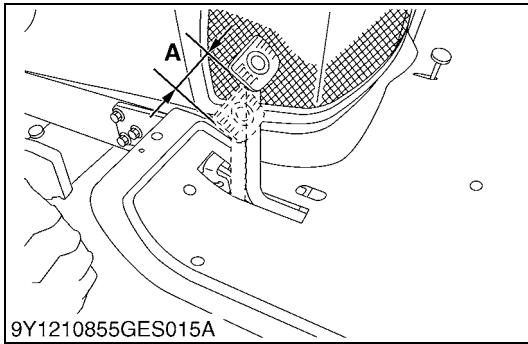

### Adjusting Brake Pedal Free Travel

**⚠ CAUTION**

- Stop the engine, remove the key, lower the implement to the ground, and chock the wheels before checking brake pedal.
- Even if the brake pedal free travel is within the limitation, adjust the brake pedal following the procedure below.

1. Release the parking brake.
2. Loosen the lock nut and turn the turnbuckle to adjust the rod length so that the brake pedal free travel is 10 mm (0.4 in.).
3. Extend the turnbuckle one additional turn.
4. Retighten the lock nut.
5. Depress the brake pedal several times and make sure the brake pedal free travel is from 25 to 35 mm (1.0 to 1.4 in.).

Brake pedal free travel	Factory specification	25 to 35 mm 1.0 to 1.4 in.
-------------------------	-----------------------	-------------------------------

- (1) Lock Nut
- (2) Turnbuckle

- A: Free Travel**
- B: Right Rear Tire**

9Y1210855GEG0029US0

## (5) Check Points of Every 200 hours

### Changing Engine Oil

1. See page G-21.

9Y1210855GEG0030US0

### Replacing Transmission Oil Filter

1. See page G-22.

9Y1210855GEG0031US0

### Replacing Engine Oil Filter

1. See page G-21.

9Y1210855GEG0032US0

### Adjusting Toe-in

1. Park tractor on a firm, flat and level place.
2. Turn steering wheel so front wheels are in the straight ahead position.
3. Lower the implement to the ground, lock the parking brake, stop the engine and remove the key.
4. Measure distance between tire beads at front of tire at hub height.
5. Measure distance between tire beads at rear of tire at hub height.
6. Front distance should be 0 to 5.0 mm (0 to 0.2 in.) less that rear distance. If not, adjust tie rod length.

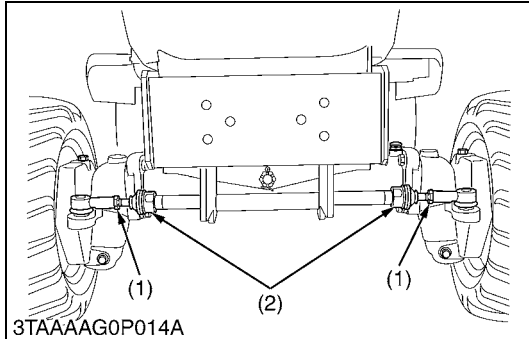
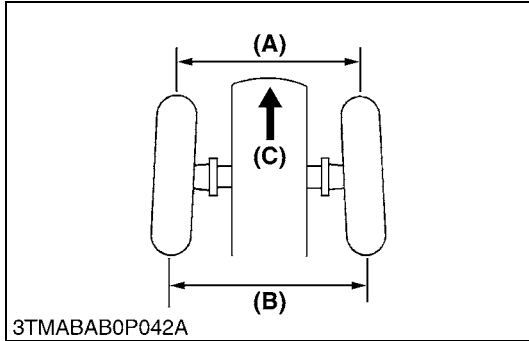

Toe-in ((B) – (A))	Factory specification	0 to 5.0 mm 0 to 0.2 in.
--------------------	-----------------------	-----------------------------

### ■ Adjusting

1. Loosen the lock nuts and turn the tie-rod to adjust the rod length until the proper toe-in measurement is obtained.
2. Retighten the lock nuts.

- (1) Lock Nut
- (2) Tie-rod

- (A) Wheel to Wheel Distance at Front
- (B) Wheel to Wheel Distance at Rear
- (C) Front

9Y1210855GEG0036US0

## (6) Check Points of Every 400 Hours

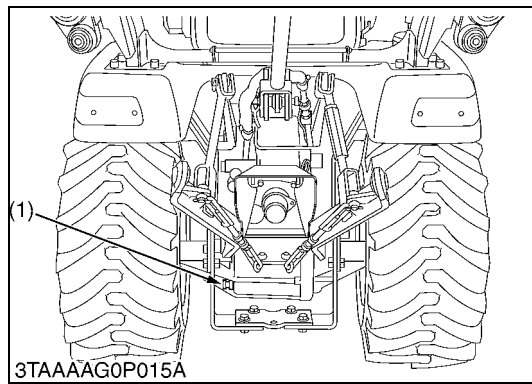

### Cleaning Transmission Oil Strainer

1. When changing the transmission fluid, disassemble and rinse the strainer with nonflammable solvent to completely clean off fillings.
2. When reassembling, be careful not to damage the parts.

■ **NOTE**

- **Since the fine fillings in the oil can damage the precision component parts of the hydraulic system, the end of the suction line is provided with an oil strainer.**

(1) Strainer

(2) Filter Plate

9Y1210855GEG0019US0

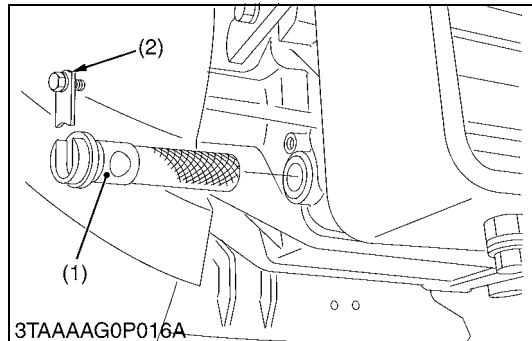

### Changing Transmission Fluid

⚠ **CAUTION**

- **Allow engine to cool down sufficiently, oil can be hot and can burn.**

1. To drain the used oil, remove the drain plug at the bottom of the transmission case and drain the oil completely into the oil pan.
2. After draining reinstall the drain plug.
3. Clean the transmission strainer.
4. Fill with new KUBOTA SUPER UDT fluid up to the upper notch on the dipstick.
5. After running the engine for a few minutes, stop it and check the oil level again, add oil to prescribed level.
6. Properly dispose of used oil.

■ **IMPORTANT**

- **Do not operate the tractor immediately after changing the transmission fluid.**
- **Run the engine at medium speed for a few minutes to prevent damage to the transmission.**

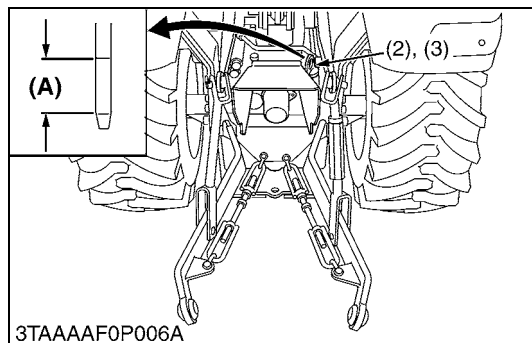
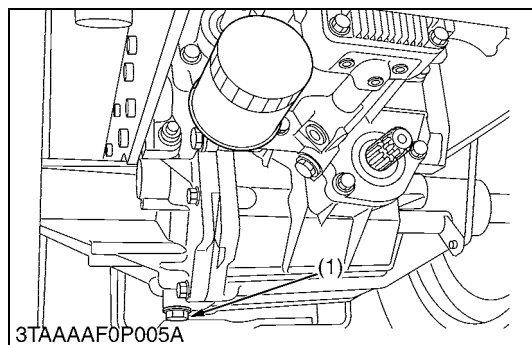

Transmission fluid	Capacity	11.6 L 3.1 U.S.gals 2.6 Imp.gals
--------------------	----------	--

- (1) Drain Plug  
(2) Filling Plug  
(3) Dipstick

**(A) Oil level is acceptable within this range.**

9Y1210855GEG0038US0

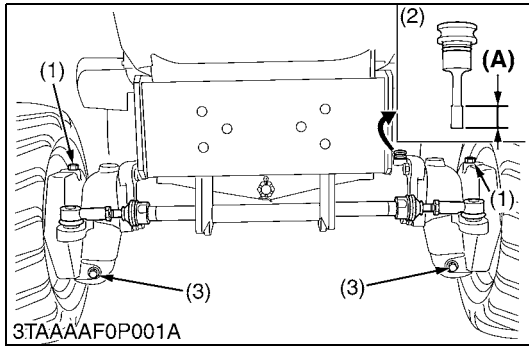

### Changing Front Axle Case Oil

1. Park the machine on a firm, flat and level surface.
2. To drain the used oil, remove the right and left drain plugs and oil gauge at the front axle case and drain the oil completely into the oil pan.
3. After draining, reinstall the drain plugs.
4. Remove the right and left breather plugs.
5. Fill with new oil up to the upper notch on the dipstick.

**■ IMPORTANT**

- After ten minutes, check the oil level again; add oil to prescribed level.
6. After filling, reinstall the oil gauge and breather plugs.

Front axle case oil	Capacity	BX1870D	2.3 L 2.4 U.S.qts 2.0 Imp.qts
		BX2370D BX2670D	4.7 L 5.0 U.S.qts 4.1 Imp.qts

- (1) Breather Plug
- (2) Oil Gauge with Dipstick
- (3) Drain Plug

**(A) Oil level is acceptable within this range.**

9Y1210855GEG0039US0

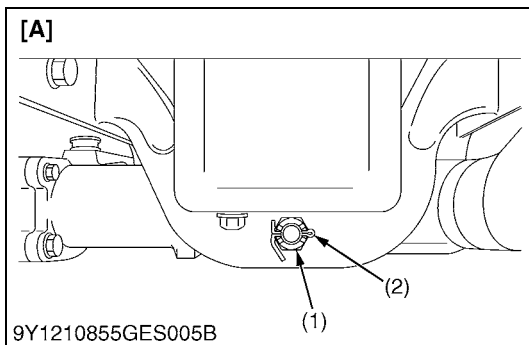

### Adjusting Front Axle Pivot

1. Remove the split pin (2), tighten the adjusting nut (1).
2. Make sure that one of the nut slots aligns with the split pin hole, tighten the nut slightly if necessary to align.
3. Replace the split pin.

Tightening torque	Adjusting nut	20 N·m 2.0 kgf·m 14 lbf·ft
-------------------	---------------	----------------------------------

- (1) Adjusting Nut
- (2) Split Pin

**[A] BX1870D and BX2370D**  
**[B] BX2670D**

9Y1210855GEG0040US0

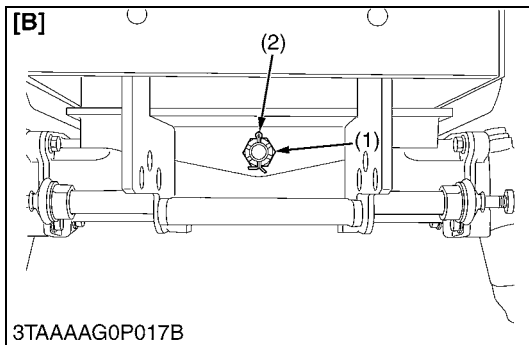

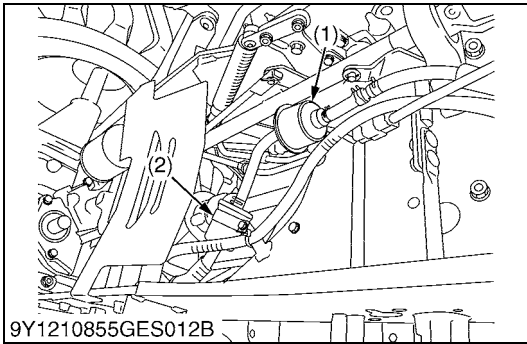

**Replacing Fuel Filter Element**

1. Disconnect the fuel hoses and replace the fuel filter (2).
2. Disconnect the fuel hoses and loosen the pipe clamp to replace the fuel filter (5).

■ **NOTE**

- If the fuel line is removed, be sure to properly bleed the fuel system. (See page G-40.)

- |                 |                 |
|-----------------|-----------------|
| (1) Fuel Pump   | (4) Hose Clamp  |
| (2) Fuel Filter | (5) Fuel Filter |
| (3) Fuel Line   |                 |

9Y1210855GEG0041US0

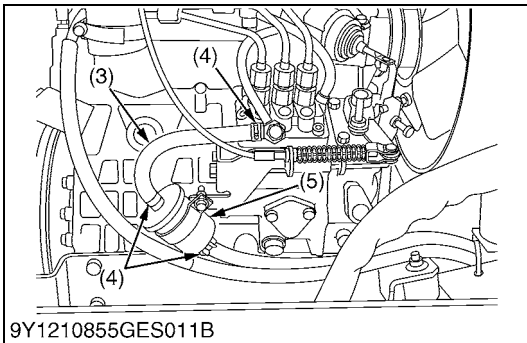

**(7) Check Point of Every 800 Hours**

**Adjusting Engine Valve Clearance**

1. See page 1-S18.

9Y1210855GEG0042US0

**(8) Check Point of Every 1000 Hours or 1 year**

**Replacing Air Cleaner Element**

1. See page G-28.

9Y1210855GEG0045US0

**(9) Check Point of Every 1500 Hours**

**Checking Fuel Injection Nozzle Injection Pressure**

1. See page 1-S24.

9Y1210855GEG0043US0

## (10) Check Point of Every 2000 Hours or 2 Years

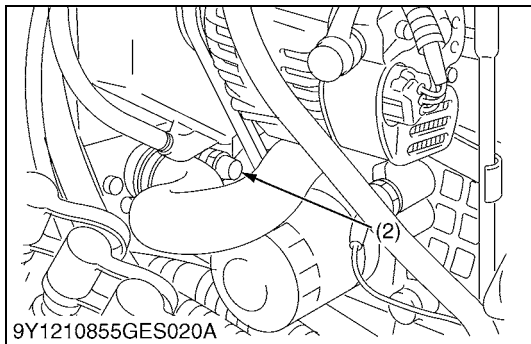
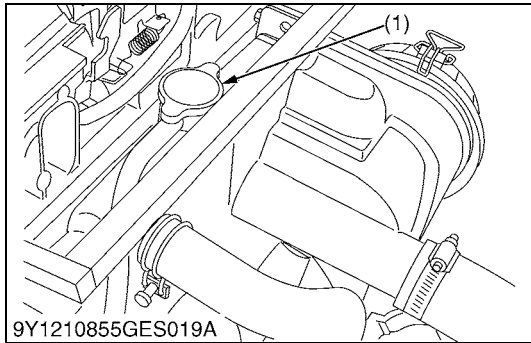

### Flush Cooling System and Changing Coolant

#### **WARNING**

To avoid personal injury or death:

- Be sure to stop the engine and remove the key before checking coolant level.
  - Do not remove the radiator cap when the engine is hot. Then loosen cap slightly to the stop to relieve any excess pressure before removing cap completely.
1. Stop the engine, remove the key and let cool down.
  2. To drain the coolant, open the radiator drain plug, and remove radiator cap. The radiator cap must be removed to completely drain the coolant.
  3. After all coolant is drained, close the drain plug.
  4. Fill with clean water and cooling system cleaner.
  5. Follow directions of the cleaner instruction.
  6. After flushing, fill with clean water and anti-freeze until the coolant level is just below the radiator cap. Install the radiator cap securely.
  7. Fill with coolant up to "H" mark on the recovery tank.
  8. Start and operate the engine for few minutes.
  9. Stop the engine, remove the key and let cool.
  10. Check coolant level of recovery tank and add coolant if necessary.

#### **IMPORTANT**

- Do not start engine without coolant.
- Use clean, fresh water and anti-freeze to fill the radiator.
- When the anti-freeze is mixed with water, the anti-freeze mixing ratio is 50 %.
- Securely tighten radiator cap. If the cap is loose or improperly fitted, water may leak out and the engine could overheat.

Coolant (with recovery tank)	Capacity	BX1870D	2.9 L 3.1 U.S.qts 2.6 Imp.qts
		BX2370D	3.1 L 3.3 U.S.qts 2.7 Imp.qts
		BX2670D	3.3 L 3.5 U.S.qts 2.9 Imp.qts

(1) Radiator Cap

(2) Drain Plug

**(To be continued)**



(Continued)

■ **Anti-Freeze**



**WARNING**

To avoid personal injury or death:

- When using antifreeze, put on some protection such as rubber gloves (Antifreeze contains position.).
- If should drink antifreeze, throw up at once and take medical attention.
- When antifreeze comes in contact with the skin or clothing, wash it off immediately.
- Do not mix different types of Antifreeze. The mixture can produce chemical reaction causing harmful substances.
- Antifreeze is extremely flammable and explosive under certain conditions. Keep fire and children away from antifreeze.
- When draining fluids from the engine, place some container underneath the engine body.
- Do not pour waste onto the grounds, down a drain, or into any water source.
- Also, observe the relevant environmental protection regulations when disposing of antifreeze.

If it freezes, coolant can damage the cylinders and radiator. If the ambient temperature falls below 0 °C (32 °F) or before a long-term storage, let out coolant completely, or mix fresh water with long-life coolant and fill the radiator and reserve tank with the mixture.

1. Long-life coolant (hereafter LLC) comes in several types. Use ethylene glycol (EG) type for this engine.
2. Before employing LLC-mixed coolant, fill the radiator with fresh water and empty it again.  
Repeat this procedure 2 or 3 times to clean up the inside.
3. Mixing the LLC.  
Put the LLC in coolant in the percentage (%) for a target temperature. When mixing, stir it up well, and then fill into the radiator.
4. The procedure for the mixing of water and antifreeze differs according to the make of the antifreeze and the ambient temperature. Refer to SAE J1034 standard, more specifically also to SAE J814c.

■ **IMPORTANT**

- When the antifreeze is mixed with water, the antifreeze mixing ratio is 50 %.

Vol % Anti-freeze	Freezing Point		Boiling Point*	
	°C	°F	°C	°F
50	-37	-34	108	226

\* At  $1.013 \times 10^5$  Pa (760 mmHg) pressure (atmospheric).

A higher boiling point is obtained by using a radiator pressure cap which permits the development of pressure within the cooling system.

**(To be continued)**

**(Continued)**

5. Adding the LLC.
  - Add only water if the mixture reduces in amount by evaporation.
  - If there is a mixture leak, add the LLC of the same manufacture and type in the same mixture percentage.
    - \* Never add any long-life coolant of different manufacture.

(Different brands may have different additive components, and the engine may fail to perform as specified.)
6. When the LLC is mixed, do not employ any radiator cleaning agent. The LLC contains anticorrosive agent. If mixed with the cleaning agent, sludge may build up, adversely affecting the engine parts.
7. Kubota's genuine long-life coolant has a service life of 2 years. Be sure to change the coolant every 2 years.

**■ NOTE**

- **The above data represent industry standards that necessitate a minimum glycol content in the concentrated antifreeze.**
- **When the coolant level drops due to evaporation, add water only to keep the antifreeze mixing ratio less than 50 %. In case of leakage, add antifreeze and water in the specified mixing ratio before filling in to the radiator.**

9Y1210855GEG0050US0

**(11) Check Point of Every 3000 Hours****Checking Injection Pump**

1. See page 1-S23.

9Y1210855GEG0044US0

## (12) Check Point of Every 1 Year

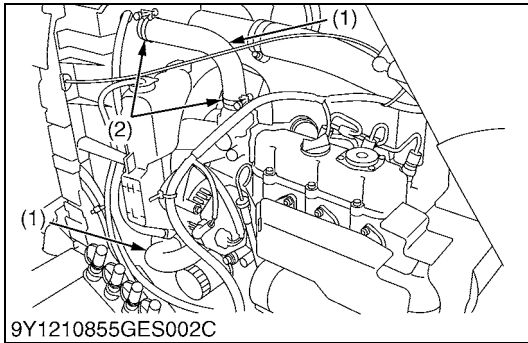

### Checking Radiator Hoses and Hose Clamps

#### **CAUTION**

- **Be sure to stop the engine and remove the key before checking radiator hose and clamp.**

Check to see if radiator hoses are properly secured every 200 hours of operation or six months, whichever comes first.

1. If hose clamps are loose or water leaks, tighten clamps securely.
2. Replace hoses and tighten hose clamps securely, if radiator hoses are swollen, hardened or cracked.
3. Properly dispose of used coolant.

Replace hoses and hose clamps every 2 years or earlier if checked and found that hoses are swollen, hardened or cracked.

#### **■ Precaution at Overheating**

Take the following actions in the event the coolant temperature be nearly or more than the boiling point, what is called "Overheating".

1. Stop the machine operation in a safe place and keep the engine idling unloaded.
2. Don't stop the engine suddenly, but stop it after about 5 minutes of unloaded idling.
3. Keep yourself well away from the machine for an additional 10 minutes or until the steam has blown out.
4. Checking that there is no danger such as burn, get rid of the cause of overheating according to the manual, see "**ENGINE**" section, and then, start the engine again.

(1) Radiator Hose

(2) Hose Clamp

9Y1210855GEG0033US0

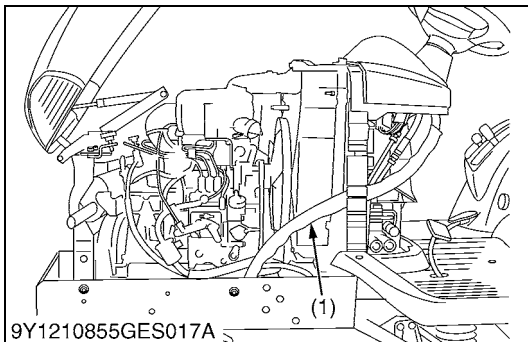

### Checking Power Steering Line

#### **CAUTION**

- **Be sure to stop the engine and remove the key before checking power steering line.**

1. Check to see that all lines are tight and not damaged.
2. If hoses are found to be worn or damaged, replace or repair them at once.

(1) Power Steering Hose

9Y1210855GEG0034US0

### Checking Fuel Line

1. Check the hoses and clamps.  
Refer to "**Checking Fuel Line and Fuel Filter**".  
(See page G-29.)

9Y1210855GEG0101US0

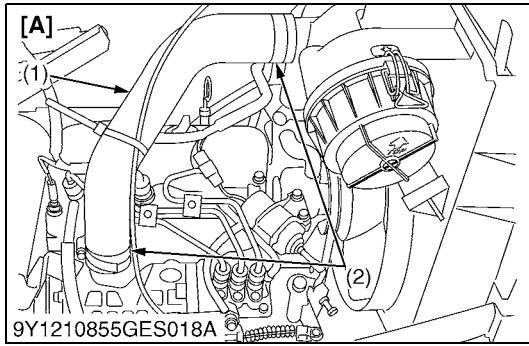

**Checking Intake Air Line**

1. Check to see that hose and hose clamps are tight and not damaged.
2. If hose and clamps are found to be worn or damaged, replace or repair them at once.

- (1) Hose
- (2) Clamp

[A] BX1870D and BX2370D  
[B] BX2670D

9Y1210855GEG0035US0

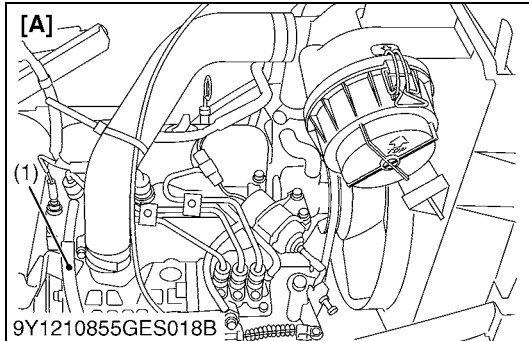
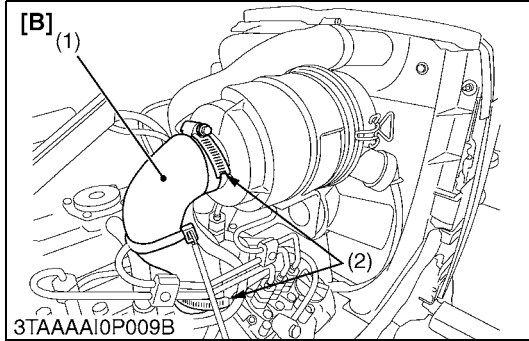

**Checking Engine Breather Hose**

1. Check to see that hose is not damaged.
2. If the hose is found worn or damaged, replace it.

- (1) Breather Hose

[A] BX1870D and BX2370D  
[B] BX2670D

9Y1210855GEG0102US0

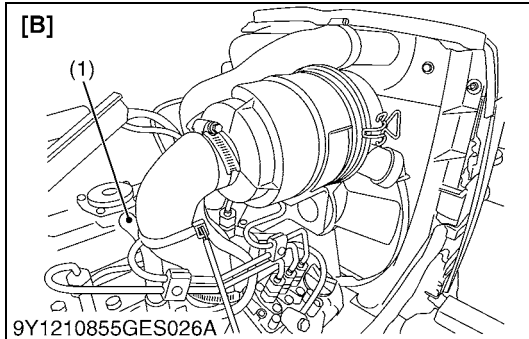

**(13) Check Points of Every 4 Years**

**Replacing Radiator Hoses (Water Pipes)**

1. Replace the hoses and clamps.  
Refer to "**Checking Radiator Hoses and Hose Clamps**".  
(See page G-38.)

9Y1210855GEG0046US0

**Replacing Power Steering Hoses**

1. Replace the hoses.  
Refer to "**Checking Power Steering Line**".  
(See page G-38.)

9Y1210855GEG0047US0

**Replacing Fuel Line**

1. Replace the hoses and clamps.  
Refer to "**Checking Fuel Line and Fuel Filter**".  
(See page G-29.)

9Y1210855GEG0048US0

**Replacing Intake Air Line**

1. Replace the intake hose.
2. Refer to "**Checking Intake Air Line**".  
(See page G-39.)

9Y1210855GEG0049US0

**Replacing Engine Breather Hose**

1. Check to see that hose is not damaged.
2. If the hose is found worn or damaged, replace it.

(1) Breather Hose

[A] BX1870D and BX2370D

[B] BX2670D

9Y1210855GEG0057US0

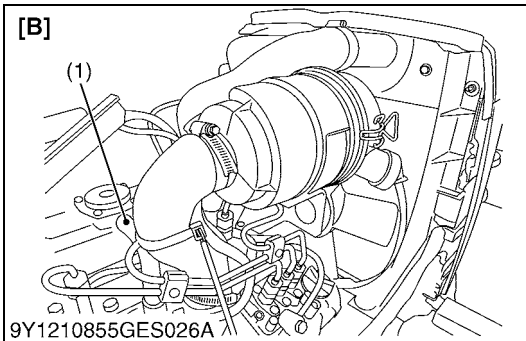
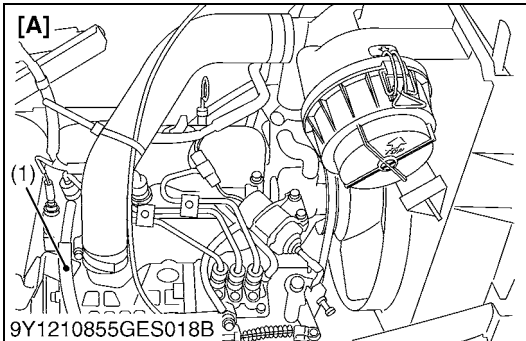

**(14) Others**

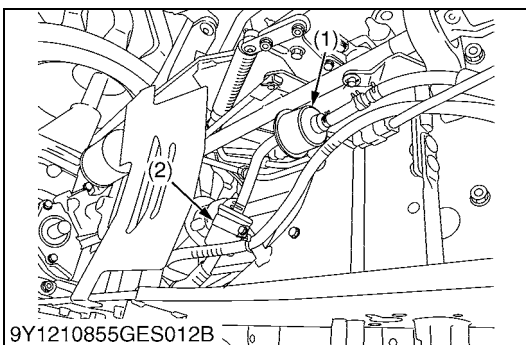

**Bleeding Fuel System**

Air must removed:

1. When the fuel filter (2) or lines are removed.
2. When tank is completely empty.
3. After the tractor has not been used for a long period of time.

■ **Bleeding procedure is as follows:**

1. Fill the fuel tank with fuel.
2. Turn the key switch to "**ON**" position for about 30 seconds.  
Doing so allows fuel pump (1) to work and pump air out of the fuel system.
3. Start the engine and run for about 30 seconds, and then stop the engine.

(1) Fuel Pump

(2) Fuel Filter

9Y1210855GEG0051US0

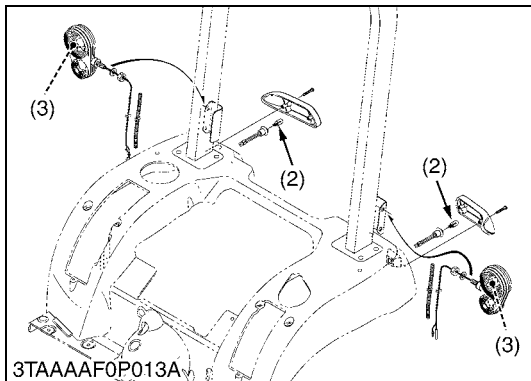
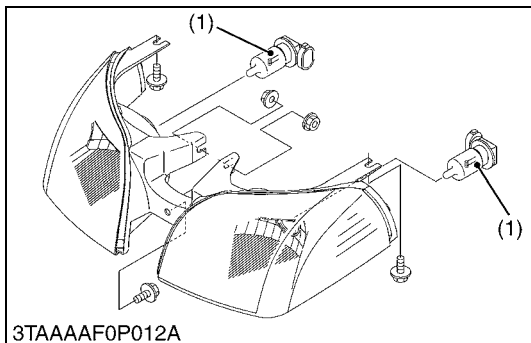
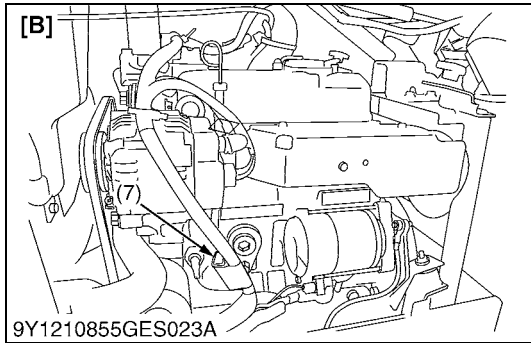
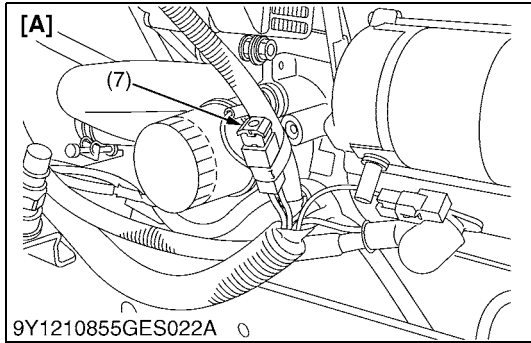
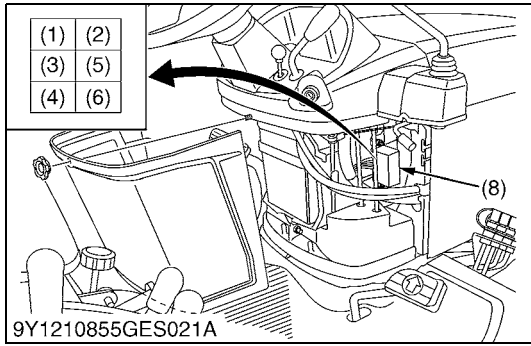

**Replacing Fuse**

1. The tractor electrical system is protected from potential damage by fuses.  
A blown fuse indicates that there is an overload or short somewhere in the electrical system.
2. If any of the fuses should blow, replace with a new one of the same capacity.

**IMPORTANT**

- Before replacing a blown fuse, determine why the fuse blew and make any necessary repairs. Failure to follow this procedure may result in serious damage to the tractor electrical system.
- If any of the fuses should blow, replace with a new one of the same capacity.

**Protected Circuit**

**[Fuse Box]**

Fuse No.	Capacity (A)	Protected circuit
(1)	15	Solenoid
(2)	15	Hazard
(3)	15	ACC
(4)	20	Working Light
(5)	10	DC Outlet
(6)	10	Timer Relay

Fuse No.	Capacity (A)	Protected circuit
(7)	Slow Blow Fuse (50 A)	Check circuit against wrong battery connection

(8) Fuse Box

[A] BX1870D and BX2370D

[B] BX2670D

9Y1210855GEG0052US0

**Replacing Light Bulb**

1. Head lights:  
Take the bulb out of the light body and replace with a new one.
2. Other lights:  
Detach the lens and replace the bulb.

Light	Capacity
Head light	37.5 W
Tail light	12.8 W
Hazard lamp	23 W

(1) Head Light

(3) Hazard Lamp

(2) Tail Light

9Y1210855GEG0053US0



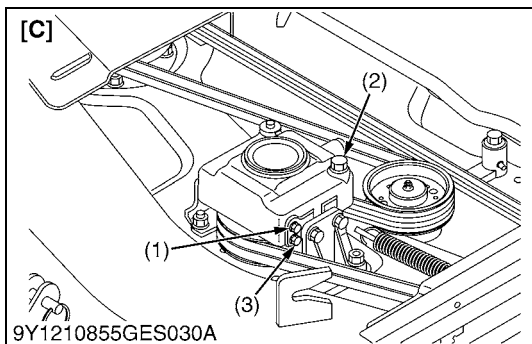
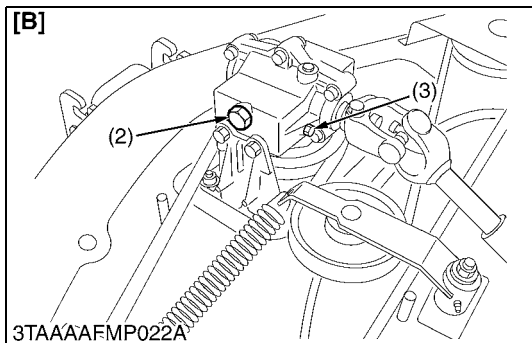
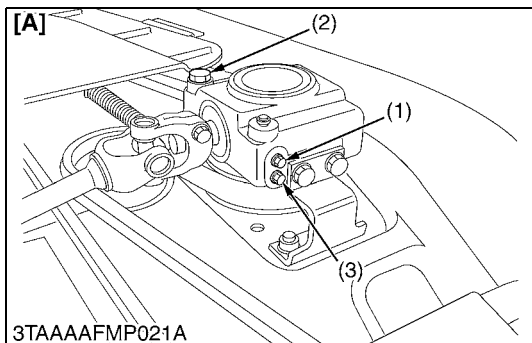

**Checking Gear Box Oil Level**

1. Place the mower on level ground.
2. Loosen the check plug (1), and check to see if oil seems from the opening.
3. If the oil level is low, remove the oil filler plug (2) and add new gear oil.

**IMPORTANT**

- Use the specified gear oil.

Refer to "[2] MOWER" on page G-12.

- (1) Check Plug
- (2) Oil Filler Plug
- (3) Drain Plug

[A] RCK60B-23BX, RCK54-23BX and RCK48-18BX

[B] RCK48P-18BX and RCK54P-23BX

[C] RCK54D-26BX and RCK60D-26BX

9Y1210855GEG0055US0



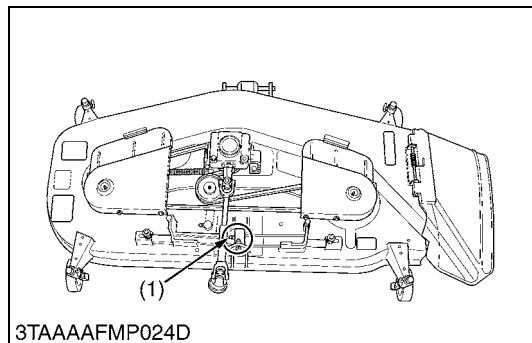
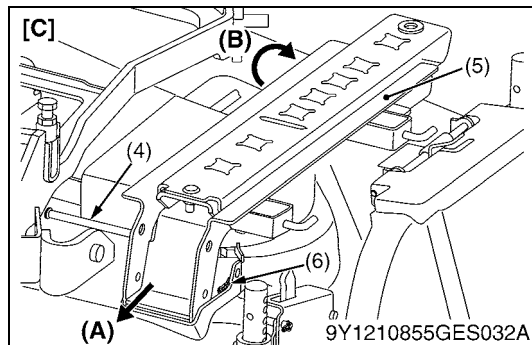
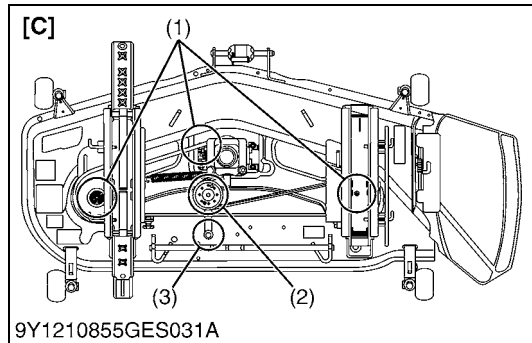
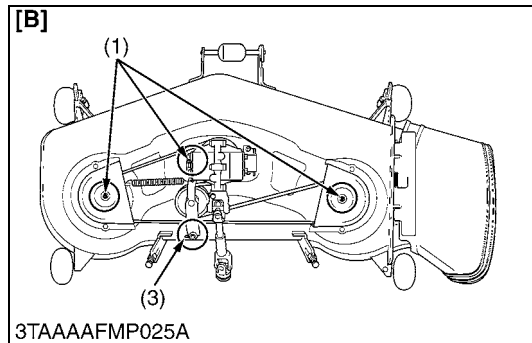
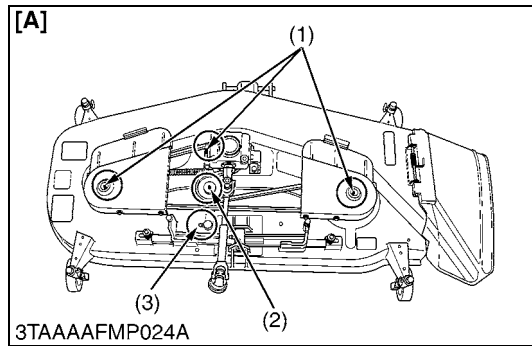

**Greasing Spindle Shafts, Belt Tension Pivot and Tension Pulley**

1. Grease the grease fittings (1), (2) of the spindle shafts if the amount of grease is insufficient.
2. **[Only for RCK54D-26BX]**  
Remove the ramp bracket (5) for greasing spindle shafts. To remove the ramp bracket (5), remove the pin (6) and clevis pin (4) and slide the ramp bracket (5) to rear side. Then lift up the ramp bracket to remove from mower deck.

**■ IMPORTANT**

- Use the specified grease.  
Refer to "[2] MOWER" on page G-12.

- |  |  |
|--|--|
| (1) Grease Fitting (Spindle Shaft)       | [A] RCK60B-23BX, RCK54-23BX and RCK48-18BX |
| (2) Grease Fitting (Belt Tension Pulley) | [B] RCK54P-23BX and RCK48P-18BX            |
| (3) Grease Fitting (Belt Tension Pivot)  | [C] RCK54D-26BX and RCK60D-26BX            |
| (4) Clevis Pin                           | (A) "REAR"                                 |
| (5) Ramp Bracket                         | (B) "UP"                                   |
| (6) Pin                                  |  |

9Y1210855GEG0058US0

**Greasing Balance Shaft [RCK60B-23BX]**

1. Grease the grease fitting (1) of the balance shaft if the amount of grease is insufficient.

**■ IMPORTANT**

- Use the specified grease.  
Refer to "[2] MOWER" on page G-12.

- (1) Grease Fitting

9Y1210855GEG0059US0

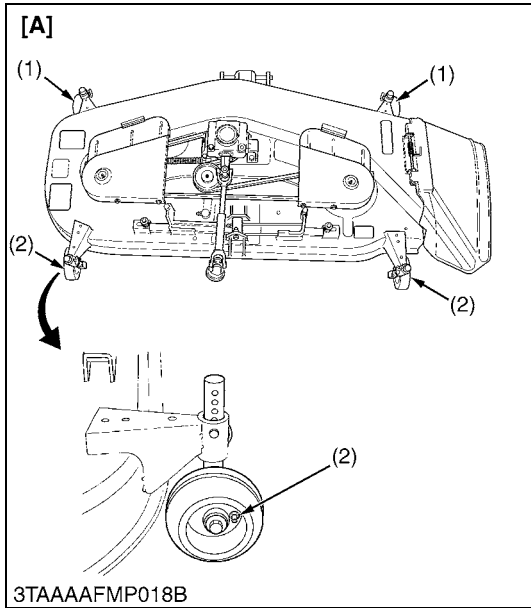

**Greasing Front and Rear Anti-scalp Rollers [RCK60B-23BX, RCK54P-23BX, RCK54-23BX, RCK54D-26BX and RCK60D-26BX]**

1. Grease the grease fitting (1), (2) of the front and rear anti-scalp rollers if the amount of grease is insufficient.

**IMPORTANT**

- Use the specified grease.  
Refer to "[2] MOWER" on page G-12.

- (1) Grease Fitting (Front Anti-scalp Roller)
- (2) Grease Fitting (Rear Anti-scalp Roller)

- [A] RCK60B-23BX, RCK54-23BX and RCK54P-23BX
- [B] RCK54D-26BX and RCK60D-26BX

9Y1210855GEG0060US0

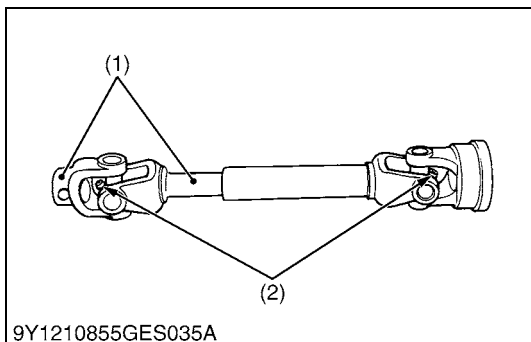
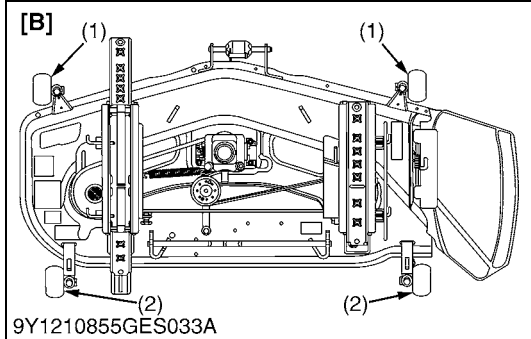

**Greasing Universal Joint**

1. Grease the internal splines (1) and grease fittings (2) of the universal joint if the amount of grease is insufficient.
2. [For RCK54D-26BX and RCK60D-26BX Only] Grease between hole and rod.

**IMPORTANT**

- Use the specified grease.  
Refer to "[2] MOWER" on page G-12.

- (1) Spline
- (2) Grease Fitting

- (3) Hole and Rod

9Y1210855GEG0056US0

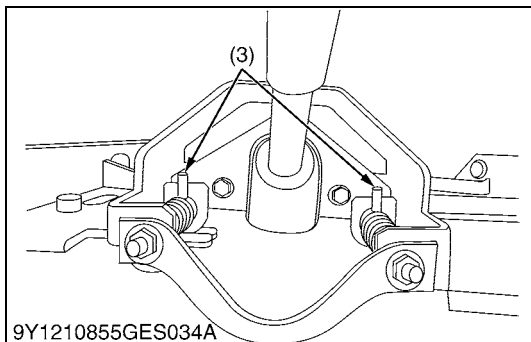

## (2) Check Point of Initial 50 Hours

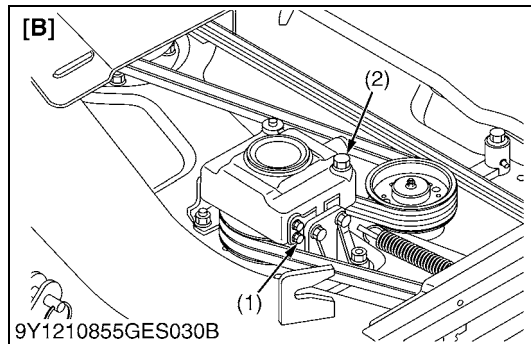
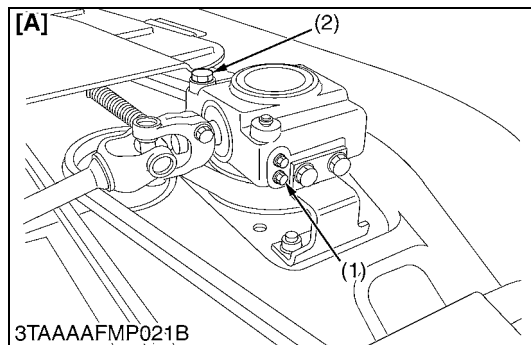

### Changing Gear Box Oil

#### ⚠ CAUTION

- Be sure to stop the engine and remove the key before changing the oil.

1. Dismount the mower from the tractor, and place the mower on level ground.
2. Remove the oil filler plug (2).
3. Remove the drain plug (1), and drain the used oil completely.
4. After draining the used oil, reinstall the drain plug.
5. Fill with new oil up to the specified level.

#### ■ IMPORTANT

- Use the specified gear oil.  
Refer to "[2] MOWER" on page G-12.

- (1) Drain Plug  
(2) Oil Filler Plug

[A] RCK60B-23BX, RCK54-23BX,  
RCK48-18BX, RCK48P-18BX and  
RCK54P-23BX

[B] RCK54D-26BX and  
RCK60D-26BX

9Y1210855GEG0061US0

## (3) Check Point of Every 150 Hours

### Changing Gear Box Oil

1. See above.

9Y1210855GEG0062US0

## (4) Check Point of Every 1 Year

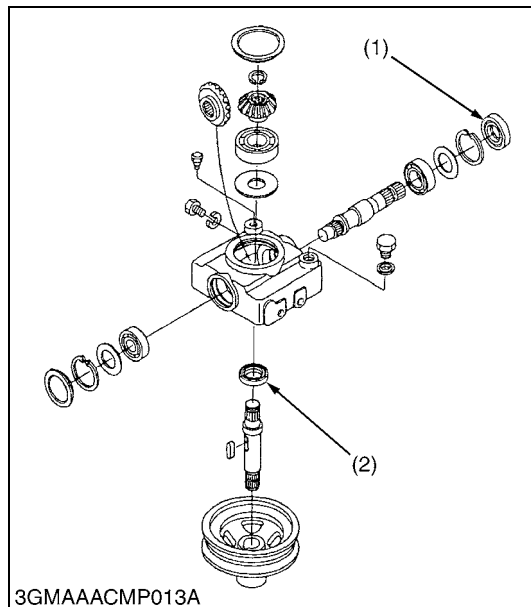

### Checking Gear Box Oil Seal

1. Check gear box oil seals (1),(2)

- (1) Oil Seal (2) Oil Seal

9Y1210855GEG0105US0

## (5) Check Point of Every 4 Years

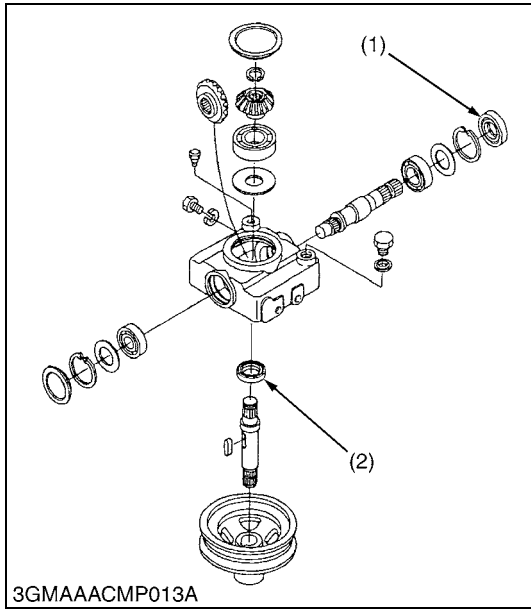

### Replacing Gear Box Oil Seal

1. Replace the gear box oil seals (1), (2) with new ones.

(1) Oil Seal

(2) Oil Seal

9Y1210855GEG0063US0

### [3] FRONT LOADER

**CAUTION**

- When checking and repairing, park the tractor on flat ground and apply the parking brake.
- When checking and repairing, lower the bucket and stop the engine.

9Y1210855GEG0064US0

#### (1) Check Points of Each Use or Daily

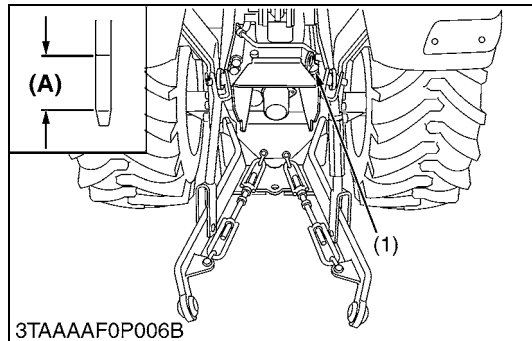

##### Checking Transmission Fluid Level

1. Check the oil level at the dipstick (1).
2. If the level is too low, add new oil to the prescribed level at the oil inlet.

**IMPORTANT**

- If oil level is low, do not run engine.

(1) Dipstick

(A) Oil level is acceptable within this range.

9Y1210855GEG0065US0

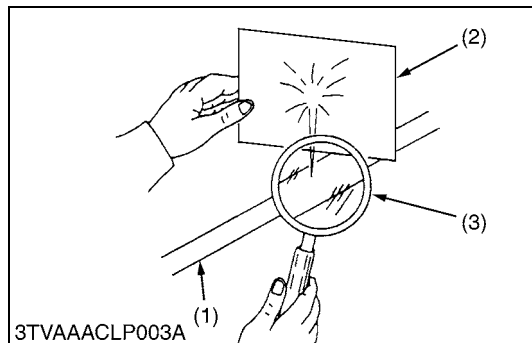

##### Checking Hydraulic Hoses

1. Checking all hydraulic hoses for cuts or wear.
2. If damages are found, replace them.

(1) Hydraulic Hose

(3) Magnifying Glass

(2) Cardboard

9Y1210855GEG0066US0

#### (2) Check Points of Every 10 Hours

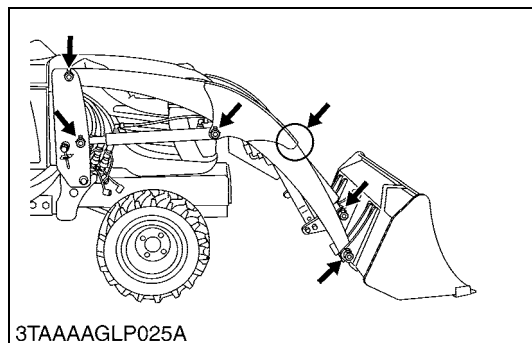

##### Greasing

1. Inject grease in all grease fitting with a hand grease gun.

9Y1210855GEG0067US0

##### Lubricating

1. Lubricate joints of control lever linkage.

9Y1210855GEG0068US0

# 8. SPECIAL TOOLS

## [1] SPECIAL TOOLS FOR ENGINE

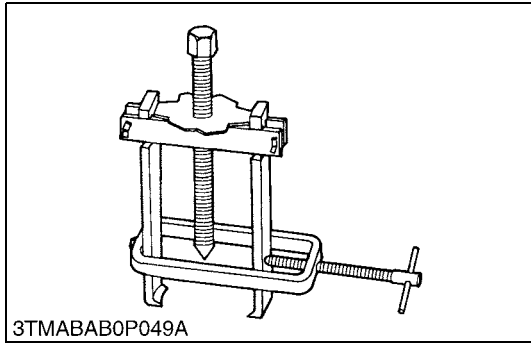

3TMABAB0P049A

### Special Use Puller Set

**Code No.**

- 07916-09032

**Application**

- Use exclusively to pull out bearing, gears and other parts with ease.

WSM000001GEG0011US0

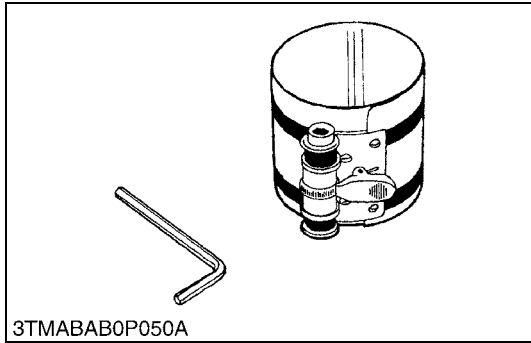

3TMABAB0P050A

### Piston Ring Compressor

**Code No.**

- 07909-32111

**Application**

- Use exclusively to push in the piston with piston rings into the cylinder.

WSM000001GEG0012US0

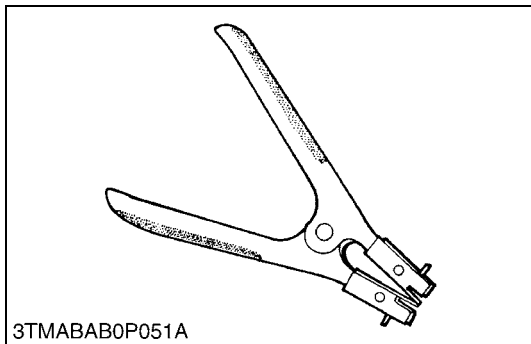

3TMABAB0P051A

### Piston Ring Tool

**Code No.**

- 07909-32121

**Application**

- Use exclusively to remove or install the piston ring with ease.

WSM000001GEG0013US0

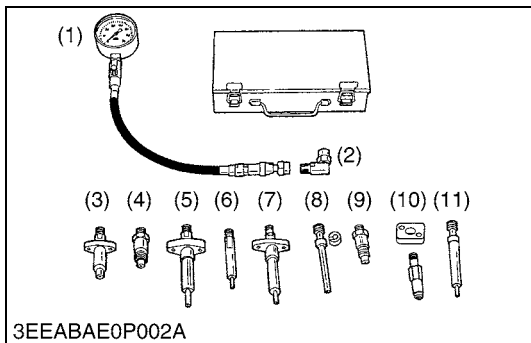

3EEABAE0P002A

### Diesel Engine Compression Tester (for Injection Nozzle)

**Code No.**

- 07909-30208 (Assembly)
- 07909-30934 (A to F)
- 07909-31211 (E and F)
- 07909-31231 (H)
- 07909-31251 (G)
- 07909-31271 (I)
- 07909-31281 (J)

**Application**

- Use to measure diesel engine compression and diagnostics of need for major overhaul.

- |               |                |
|---------------|----------------|
| (1) Gauge     | (7) Adaptor F  |
| (2) L Joint   | (8) Adaptor G  |
| (3) Adaptor A | (9) Adaptor H  |
| (4) Adaptor B | (10) Adaptor I |
| (5) Adaptor C | (11) Adaptor J |
| (6) Adaptor E |                |

WSM000001GEG0014US0

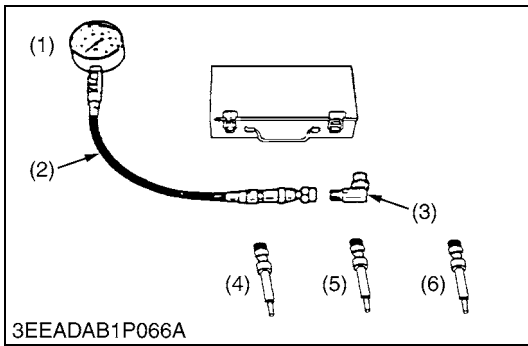

**Diesel Engine Compression Tester (for Glow Plug)**

**Code No.**

- 07909-39081 (Assembly)
- 07909-31291 (K)
- 07909-31301 (L)
- 07909-31311 (M)

**Application**

- Use to measure diesel engine compression and diagnosis of need for major overhaul.

- |                   |               |
|-------------------|---------------|
| (1) Gauge         | (4) Adaptor K |
| (2) Hose Assembly | (5) Adaptor L |
| (3) L Joint       | (6) Adaptor M |

WSM000001GEG0096US0

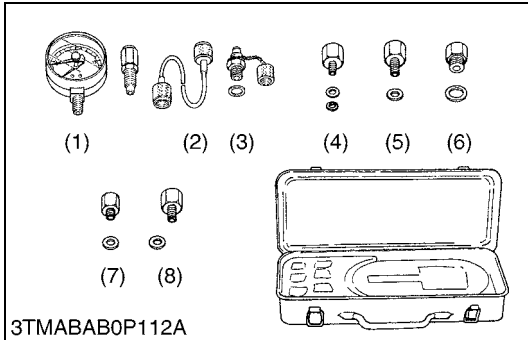

**Oil Pressure Tester**

**Code No.**

- 07916-32032

**Application**

- Use to measure lubricating oil pressure.

- |                    |               |
|--------------------|---------------|
| (1) Gauge          | (5) Adaptor 2 |
| (2) Cable          | (6) Adaptor 3 |
| (3) Threaded Joint | (7) Adaptor 4 |
| (4) Adaptor 1      | (8) Adaptor 5 |

WSM000001GEG0015US0

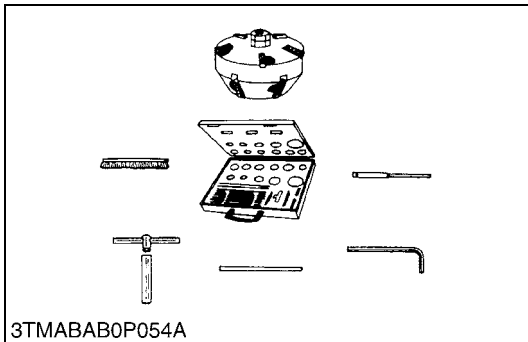

**Valve Seat Cutter**

**Code No.**

- 07909-33102

**Application**

- Use to reseal valves.

**Angle**

- 0.79 rad (45°)
- 0.26 rad (15°)

**Diameter**

- 28.6 mm (1.13 in.)
- 31.6 mm (1.24 in.)
- 35.0 mm (1.38 in.)
- 38.0 mm (1.50 in.)
- 41.3 mm (1.63 in.)
- 50.8 mm (2.00 in.)

WSM000001GEG0016US0

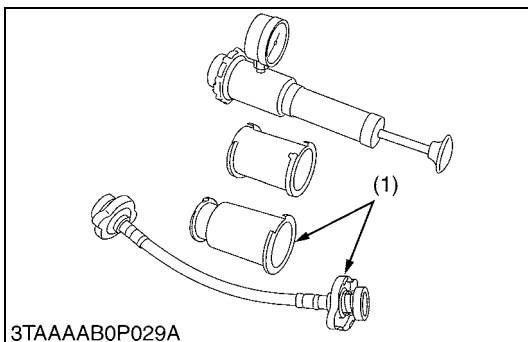

**Radiator Tester**

**Code No.**

- 07909-31551

**Application**

- Use to check of radiator cap pressure, and leaks from cooling system.

**Remarks**

- Adaptor (1) BANZAI Code No. RCT-2A-30S.

- |             |
|-------------|
| (1) Adaptor |
|-------------|

WSM000001GEG0017US0

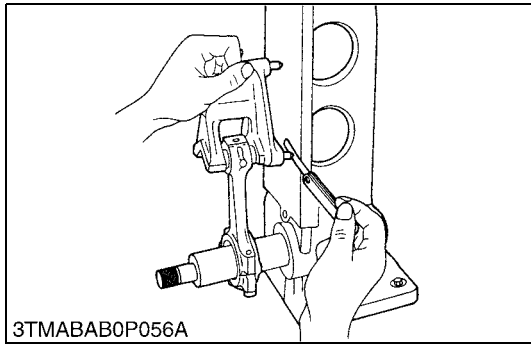

**Connecting Rod Alignment Tool**

**Code No.**

- 07909-31661

**Application**

- Use to check the connecting rod alignment.

**Applicable range**

- Connecting rod big end I.D.  
30 to 75 mm dia. (1.2 to 2.9 in. dia.)
- Connecting rod length  
65.0 to 300 mm (2.56 to 11.8 in.)

WSM000001GEG0020US0

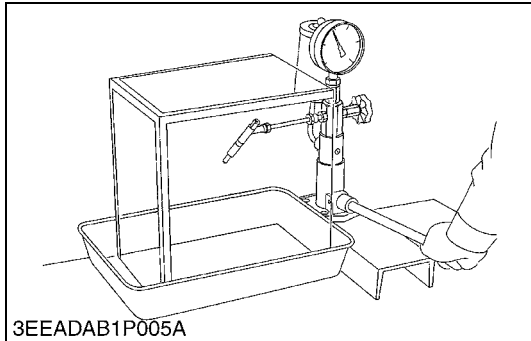

**Nozzle Tester**

**Code No.**

- 07909-31361

**Application**

- Use to check the fuel injection pressure and spray pattern of nozzle.

**Measuring range**

- 0 to 50 MPa (0 to 500 kgf/cm<sup>2</sup>, 0 to 7200 psi)

WSM000001GEG0021US0

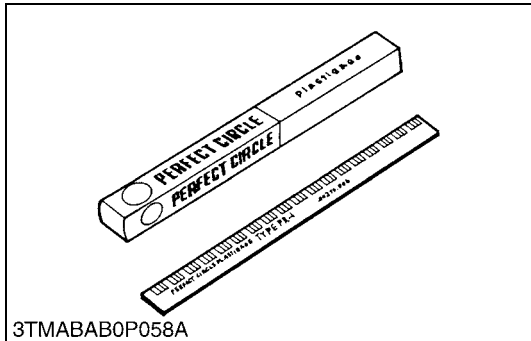

**Plastigauge**

**Code No.**

- 07909-30241

**Application**

- Use to check the oil clearance between crankshaft and bearing, etc..

**Measuring range**

- Green: 0.03 to 0.07 mm (0.001 to 0.003 in.)
- Red: 0.05 to 0.1 mm (0.002 to 0.006 in.)
- Blue: 0.1 to 0.2 mm (0.004 to 0.009 in.)

WSM000001GEG0022US0

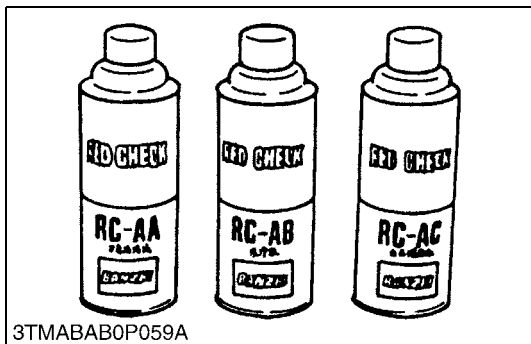

**Red Check**

**Code No.**

- 07909-31371

**Application**

- Use to check cracks on cylinder head, cylinder block, etc..

WSM000001GEG0023US0



■ **NOTE**

- The following special tools are not provide, so make them referring to the figure.

9Y1210855GEG0069US0

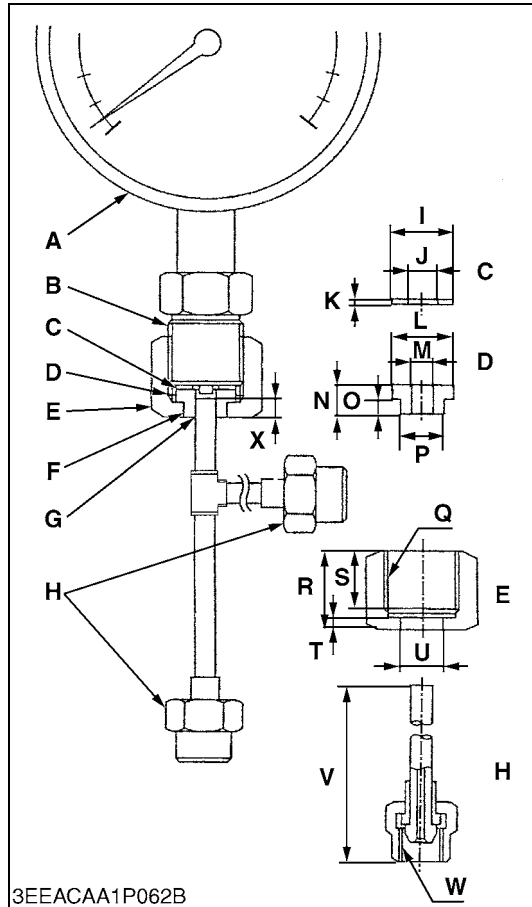

**Injection Pump Pressure Tester**

**Application**

- Use to check fuel tightness of injection pumps.

<b>A</b>	Pressure gauge fuel scale: More than 29.4 MPa (300 kgf/cm <sup>2</sup> , 4267 psi)
<b>B</b>	PF 1/2
<b>C</b>	Copper gasket
<b>D</b>	Flange (Material: Steel)
<b>E</b>	Hex. nut 27 mm (1.1 in.) across the plat
<b>F</b>	Adhesive application
<b>G</b>	Fillet welding on the enter circumference
<b>H</b>	Retaining nut
<b>I</b>	17 mm dia. (0.67 in. dia.)
<b>J</b>	8.0 mm dia. (0.31 in. dia.)
<b>K</b>	1.0 mm dia. (0.039 in. dia.)
<b>L</b>	17 mm dia. (0.67 in. dia.)
<b>M</b>	6.10 to 6.20 mm dia. (0.241 to 0.244 in. dia.)
<b>N</b>	8.0 mm (0.31 in.)
<b>O</b>	4.0 mm (0.16 in.)
<b>P</b>	11.97 to 11.99 mm dia. (0.4713 to 0.4720 in. dia.)
<b>Q</b>	PD 1/2
<b>R</b>	23 mm (0.91 in.)
<b>S</b>	17 mm (0.67 in.)
<b>T</b>	4.0 mm (0.16 in.)
<b>U</b>	12.00 to 12.02 mm dia. (0.472 to 0.4732 in. dia.)
<b>V</b>	100 mm (3.94 in.)
<b>W</b>	M12 × P1.5
<b>X</b>	5.0 mm (0.20 in.)

9Y1210855GEG0070US0

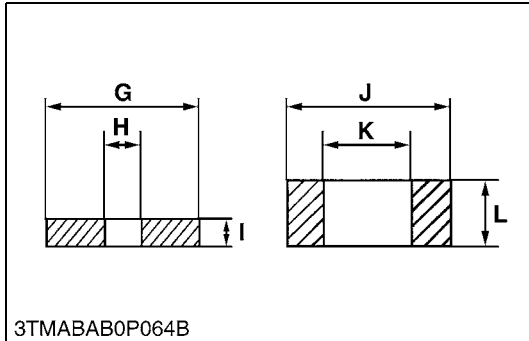
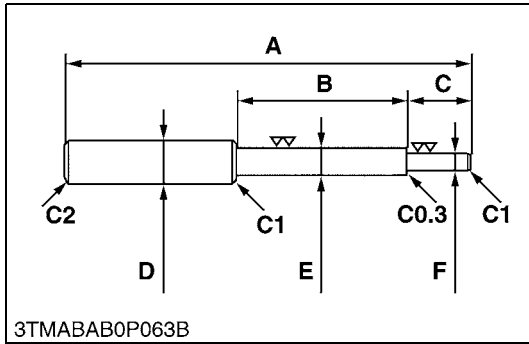

**Valve Guide Replacing Tool**

**Application**

- Use to press out and press fit the valve guide.

	<b>BX1870D (D722-E4)</b>	<b>BX2370D (D902-E4)</b>	<b>BX2670D (D1005-E4)</b>
<b>A</b>	220 mm (8.66 in.)		225 mm (8.86 in.)
<b>B</b>	80 mm (3.1 in.)		70 mm (2.8 in.)
<b>C</b>	40 mm (1.6 in.)		45 mm (1.8 in.)
<b>D</b>	20 mm dia. (0.79 in. dia.)		
<b>E</b>	9.960 to 9.980 mm dia. (0.3922 to 0.3929 in. dia.)		11.7 to 11.9 mm dia. (0.461 to 0.468 in. dia.)
<b>F</b>	5.50 to 5.70 mm dia. (0.217 to 0.224 in. dia.)		6.50 to 6.60 mm dia. (0.256 to 0.259 in. dia.)
<b>G</b>	25 mm dia. (0.98 in. dia.)		
<b>H</b>	6.00 to 6.10 mm dia. (0.237 to 0.240 in. dia.)		6.70 to 7.00 mm dia. (0.264 to 0.275 in. dia.)
<b>I</b>	5.0 mm (0.20 in.)		
<b>J</b>	18 mm dia. (0.71 in. dia.)		20 mm dia. (0.79 in. dia.)
<b>K</b>	10.6 to 10.7 mm dia. (0.418 to 0.421 in. dia.)		12.5 to 12.8 mm dia. (0.493 to 0.503 in. dia.)
<b>L</b>	6.90 to 7.10 mm (0.272 to 0.279 in.)		8.90 to 9.10 mm (0.351 to 0.358 in.)
<b>C1</b>	Chamfer 1.0 mm (0.039 in.)		
<b>C2</b>	Chamfer 2.0 mm (0.079 in.)		
<b>C0.3</b>	Chamfer 0.3 mm (0.012 in.)		

9Y1210855GEG0071US0

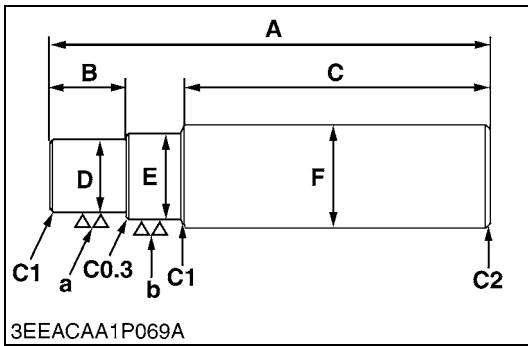

**Bushing Replacing Tool [For BX1870D (D722-E4) and BX2370D (D902-E4)]**

**Application**

- Use to press out and press fit the bushing.

**[For small end bushing]**

<b>A</b>	145 mm (5.71 in.)
<b>B</b>	20 mm (0.79 in.)
<b>C</b>	100 mm (3.94 in.)
<b>D</b>	19.90 to 19.95 mm dia. (0.7835 to 0.7854 in. dia.)
<b>E</b>	21.90 to 21.95 mm dia. (0.8622 to 0.8642 in. dia.)
<b>F</b>	25 mm dia. (0.98 in. dia.)
<b>C1</b>	Chamfer 1.0 mm (0.039 in.)
<b>C2</b>	Chamfer 2.0 mm (0.079 in.)
<b>C0.3</b>	Chamfer 0.3 mm (0.012 in.)
<b>a</b>	6.3 μm (250 μin.)
<b>b</b>	6.3 μm (250 μin.)

**[For idle gear bushing]**

<b>A</b>	150 mm (5.91 in.)
<b>B</b>	23 mm (0.91 in.)
<b>C</b>	100 mm (3.94 in.)
<b>D</b>	19.90 to 19.95 mm dia. (0.7835 to 0.7854 in. dia.)
<b>E</b>	21.90 to 21.95 mm dia. (0.8622 to 0.8642 in. dia.)
<b>F</b>	25 mm dia. (0.98 in. dia.)
<b>C1</b>	Chamfer 1.0 mm (0.039 in.)
<b>C2</b>	Chamfer 2.0 mm (0.079 in.)
<b>C0.3</b>	Chamfer 0.3 mm (0.012 in.)
<b>a</b>	6.3 μm (250 μin.)
<b>b</b>	6.3 μm (250 μin.)

9Y1210855GEG0072US0

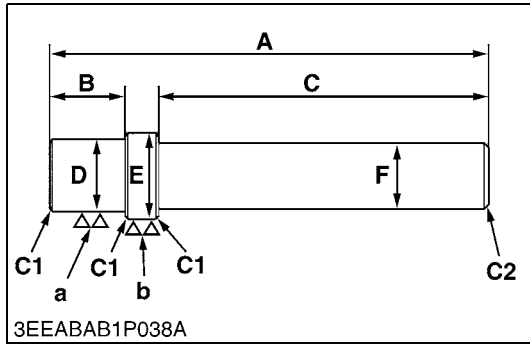

**Bushing Replacing Tool [For BX2670D (D1005-E4)]**

**Application**

- Use to press out and press fit the valve guide.

**[For small end bushing]**

<b>A</b>	157 mm (6.18 in.)
<b>B</b>	24 mm (0.94 in.)
<b>C</b>	120 mm (4.72 in.)
<b>D</b>	21.8 to 21.9 mm dia. (0.859 to 0.862 in. dia.)
<b>E</b>	24.8 to 24.9 mm dia. (0.977 to 0.980 in. dia.)
<b>F</b>	20 mm dia. (0.79 in. dia.)
<b>a</b>	6.3 μm (250 μin.)
<b>b</b>	6.3 μm (250 μin.)
<b>C1</b>	Chamfer 1.0 mm (0.039 in.)
<b>C2</b>	Chamfer 2.0 mm (0.0079 in.)

**[For idle gear bushing]**

<b>A</b>	196 mm (7.72 in.)
<b>B</b>	26 mm (1.0 in.)
<b>C</b>	150 mm (5.91 in.)
<b>D</b>	25.80 to 25.90 mm dia. (1.016 to 1.019 in. dia.)
<b>E</b>	28.80 to 28.90 mm dia. (1.134 to 1.137 in. dia.)
<b>F</b>	20 mm dia. (0.79 in. dia.)
<b>a</b>	6.3 μm (250 μin.)
<b>b</b>	6.3 μm (250 μin.)
<b>C1</b>	Chamfer 1.0 mm (0.039 in.)
<b>C2</b>	Chamfer 2.0 mm (0.0079 in.)

9Y1210855GEG0073US0

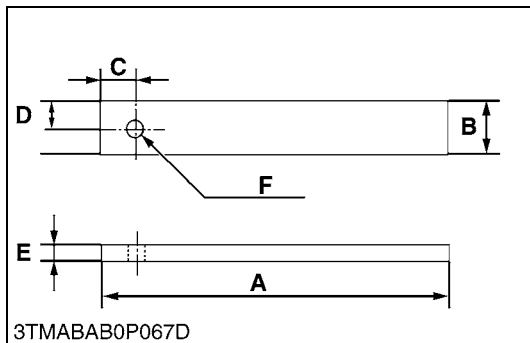

**Flywheel Stopper**

**Application**

- Use to loosen and tighten the flywheel screw.

<b>A</b>	200 mm (7.87 in.)
<b>B</b>	30 mm (1.18 in.)
<b>C</b>	20 mm (0.79 in.)
<b>D</b>	15 mm (0.59 in.)
<b>E</b>	8 mm (0.31 in.)
<b>F</b>	10 mm dia. (0.39 in. dia.)

9Y1210855GEG0074US0

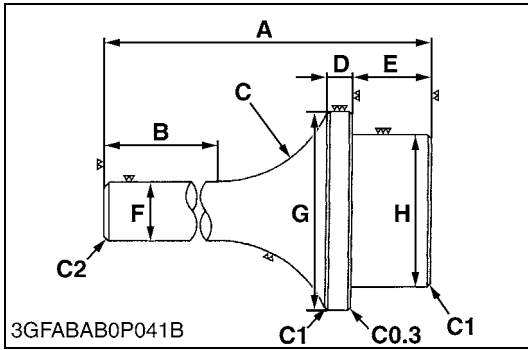

### Crankshaft Bearing 1 Replacing Tool

#### Application

- Use to press out and press fit the crankshaft bearing 1.

#### [Press Out]

	BX1870D (D722-E4)	BX2370D (D902-E4)	BX2670D (D1005-E4)
<b>A</b>	135 mm (5.31 in.)		
<b>B</b>	72 mm (2.8 in.)		
<b>C</b>	40 mm radius (1.6 in. radius)		
<b>D</b>	10 mm dia. (0.39 in. dia.)		
<b>E</b>	22 mm (0.87 in.)	24 mm (0.94 in.)	
<b>F</b>	20 mm dia. (0.79 in. dia.)		
<b>G</b>	47.90 to 47.95 mm dia. (1.886 to 1.887 in. dia.)		51.20 to 51.40 mm dia. (2.016 to 2.023 in. dia.)
<b>H</b>	43.90 to 43.95 mm dia. (1.729 to 1.730 in. dia.)		47.30 to 47.50 mm dia. (1.863 to 1.870 in. dia.)
<b>C1</b>	Chamfer 1.0 mm (0.039 in.)		
<b>C2</b>	Chamfer 2.0 mm (0.079 in.)		
<b>C0.3</b>	Chamfer 0.30 mm (0.012 in.)		

#### [Press Fit]

	BX1870D (D722-E4)	BX2370D (D902-E4)	BX2670D (D1005-E4)
<b>A</b>	130 mm (5.12 in.)		
<b>B</b>	72 mm (2.83 in.)		
<b>C</b>	40 mm radius (1.6 in. radius)		
<b>D</b>	9.0 mm (0.35 in.)		
<b>E</b>	24 mm (0.94 in.)		
<b>F</b>	20 mm dia. (0.79 in. dia.)		
<b>G</b>	68 mm dia. (2.7 in. dia.)		
<b>H</b>	39.90 to 39.95 mm dia. (1.571 to 1.572 in. dia.)	43.90 to 43.95 mm dia. (1.729 to 1.730 in. dia.)	47.30 to 47.50 mm dia. (1.863 to 1.870 in. dia.)
<b>C1</b>	Chamfer 1.0 mm (0.039 in.)		
<b>C2</b>	Chamfer 2.0 mm (0.079 in.)		
<b>C0.3</b>	Chamfer 0.30 mm (0.012 in.)		

9Y1210855GEG0075US0

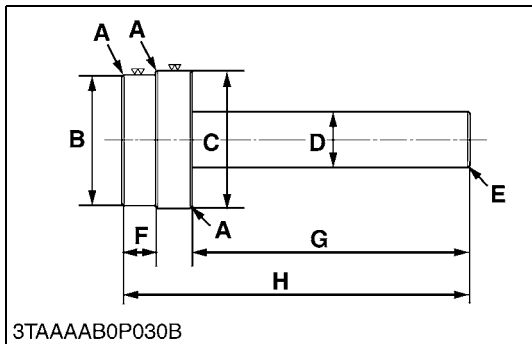

**Governor Gear Holder Busing Replacing Tool [For BX2670D (D1005-E4)]**

**Application**

- Use to press out and press fit the governor gear holder bushing.

<b>A</b>	C1: Chamfer 1.0 mm (0.039 in.)
<b>B</b>	73.90 to 74.00 mm dia. (2.910 to 2.913 in. dia.)
<b>C</b>	69.80 to 69.90 mm dia. (2.748 to 2.751 in. dia.)
<b>D</b>	30 mm dia. (1.2 in. dia.)
<b>E</b>	C2: Chamfer 2.0 mm (0.079 in.)
<b>F</b>	18 mm (0.71 in.)
<b>G</b>	150 mm (5.91 in.)
<b>H</b>	188 mm (7.40 in.)

9Y1210855GEG0076US0

## [2] SPECIAL TOOLS FOR TRACTOR

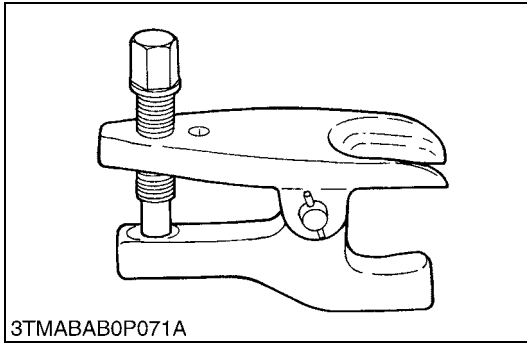

### Tie-rod End Lifter

**Code No.**

- 07909-39051

**Application**

- Use to remove the tie-rod end with ease.

WSM000001GEG0029US0

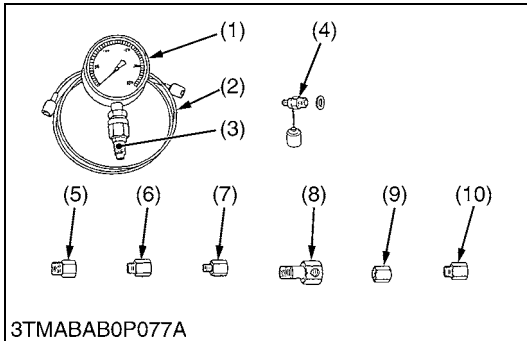

### Relief Valve Pressure Tester

**Code No.**

- 07916-50045

**Application**

- This allows easy measurement of relief set pressure.

- |  |                                       |
|--|---------------------------------------|
| (1) Gauge (07916-50322)                  | (6) Adaptor C (PS3/8) (07916-50371)   |
| (2) Cable (07916-50331)                  | (7) Adaptor D (PT1/8) (07916-50381)   |
| (3) Threaded Joint (07916-50401)         | (8) Adaptor E (PS3/8) (07916-50392)   |
| (4) Threaded Joint (07916-50341)         | (9) Adaptor F (PF1/2) (07916-62601)   |
| (5) Adaptor B (M18 × P1.5) (07916-50361) | (10) Adaptor 58 (PT1/4) (07916-52391) |

WSM000001GEG0027US0

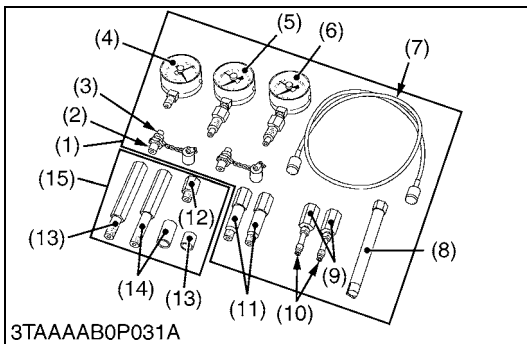

### Hydrostatic Transmission Tester and HST Adaptor Set

**Code No.**

- 07916-52040 (Hydrostatic Transmission Tester)
- 07916-53072 (HST Adaptor Set)

**Application**

- This allows easy measurement of hydrostatic transmission pressure.

- |  |  |
|--|--|
| (1) Hydrostatic Transmission Tester (07916-52040)                                      | (8) Valve Seat Driver (07916-60841)      |
| (2) Gasket (04714-00200)   | (9) Connector 1 (07916-60811)            |
| (3) Connector 3 (07916-51331)  | (10) Connector 2 (07916-60821)           |
| (4) Vacuum Gauge (07916-51331)   | (11) Long Connector (07916-60831)        |
| (5) Pressure Gauge (Low Pressure) (07916-51301)  | (12) Adaptor 1 (07916-52621)             |
| (6) Pressure Gauge (High Pressure) (in Relief Valve Set Pressure Tester) (07916-50321) | (13) Adaptor 2 with Collar (07916-52632) |
| (7) HN Tube (in Relief Valve Set Pressure Tester) (07916-50331)                        | (14) Adaptor 3 with Collar (07916-52642) |
|  | (15) HST Adaptor Set (07916-53072)       |

WSM000001GEG0104US0

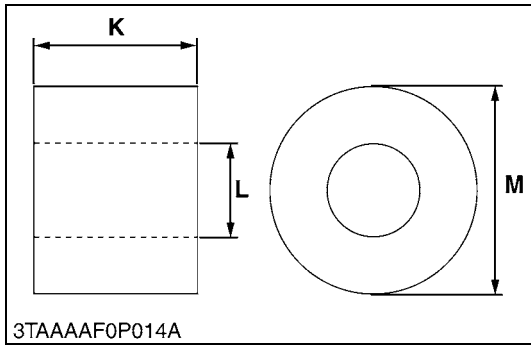
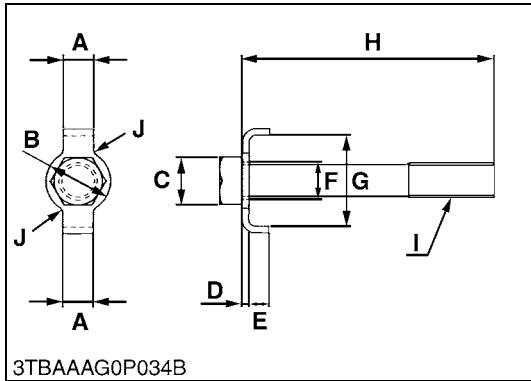

**Independent PTO Clutch Spring Compression Tool**

**Application**

- Use for compressing the spring into the spline boss.  
This tool can be used for B30 series, BX50 series, BX60 series, BX24 and BX25 tractor.

A	12 mm (0.47 in.)
B	25.4 mm (1.00 in.)
C	19 mm radius (0.75 in.) Hex.
D	2.7 mm (0.11 in.)
E	8 mm (0.31 in.)
F	15 mm dia. (0.59 in. dia.)
G	37 mm (1.46 in.)
H	70 mm (2.76 in.)
I	M14 ×1.5
J	R 3 mm (0.12 in.)
K	30 mm (1.18 in.)
L	17 mm (0.67 in.)
M	38 mm (1.50 in.)

9Y1210855GEG0077US0



**Disassembling and Assembling Stand (1/2)**

**Application**

- Use to disassembling transaxle assembly and to assembling transaxle assembly.

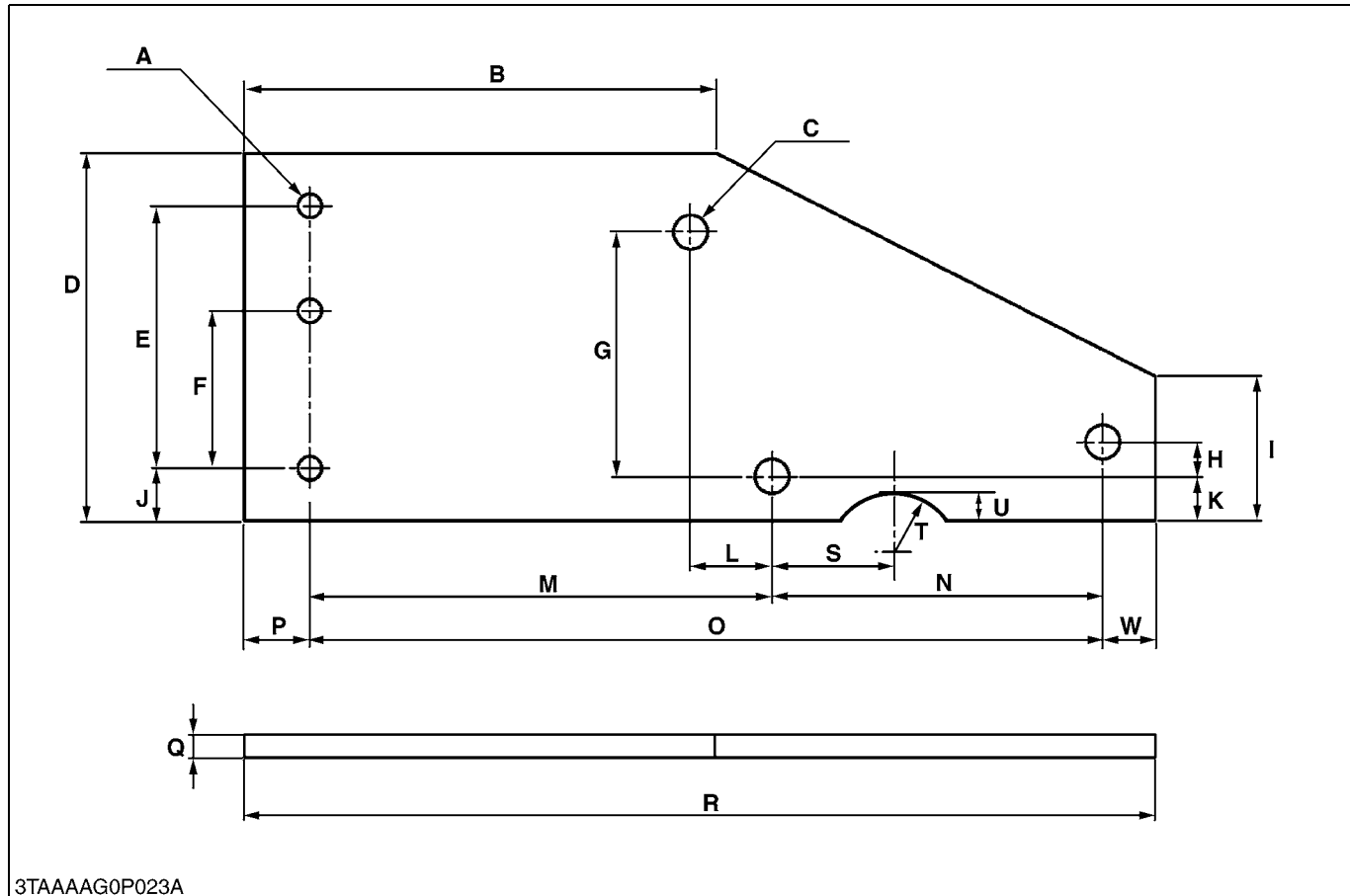

3TAAAAG0P023A

<b>A</b>	φ9 mm (φ0.35 in.) 3 Holes	<b>L</b>	30.5 to 31.5 mm (1.21 to 1.24 in.)
<b>B</b>	225 mm (8.86 in.)	<b>M</b>	226 mm (8.90 in.)
<b>C</b>	φ13 mm (φ0.51 in.) 3 Holes	<b>N</b>	125.5 to 126.5 mm (4.95 to 4.98 in.)
<b>D</b>	140 mm (5.51 in.)	<b>O</b>	352 mm (13.86 in.)
<b>E</b>	99.5 to 100.5 mm (3.92 to 3.95 in.)	<b>P</b>	25 mm (0.98 in.)
<b>F</b>	59.5 to 60.5 mm (2.35 to 2.38 in.)	<b>Q</b>	9.5 mm (0.37 in.)
<b>G</b>	92.5 to 93.5 mm (3.65 to 3.68 in.)	<b>R</b>	397 mm (15.63 in.)
<b>H</b>	12.5 to 13.5 mm (0.50 to 0.53 in.)	<b>S</b>	46 mm (1.81 in.)
<b>I</b>	55 mm (2.17 in.)	<b>T</b>	R25 mm (0.98 in.)
<b>J</b>	20 mm (0.79 in.)	<b>U</b>	11 mm (0.43 in.)
<b>K</b>	17 mm (0.67 in.)	<b>W</b>	20 mm (0.79 in.)

9Y1210855GEG0078US0

**Disassembling and Assembling Stand (2/2)**

**Application**

- Use to disassembling transaxle assembly and to assembling transaxle assembly.

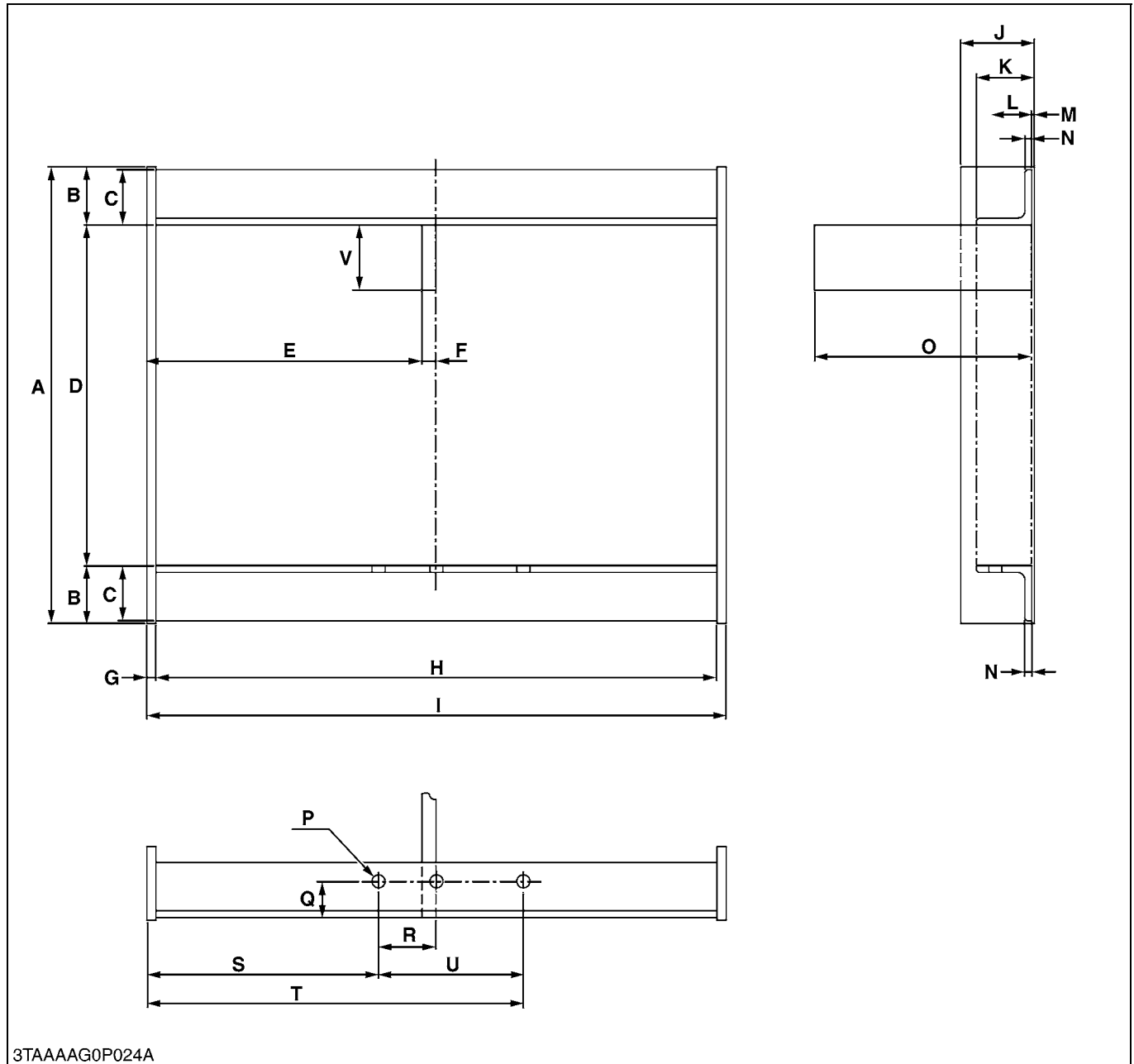

<b>A</b>	311 mm (12.24 in.)	<b>L</b>	38.1 mm (1.50 in.)
<b>B</b>	40 mm (1.57 in.)	<b>M</b>	1.9 mm (0.07 in.)
<b>C</b>	38.1 mm (1.50 in.)	<b>N</b>	4.8 mm (0.19 in.)
<b>D</b>	235 mm (9.25 in.)	<b>O</b>	200 mm (7.87 in.)
<b>E</b>	170 mm (6.69 in.)	<b>P</b>	φ9 mm (φ0.35 in.), 3 Holes
<b>F</b>	9.5 mm (0.37 in.)	<b>Q</b>	25 mm (0.98 in.)
<b>G</b>	6.4 mm (0.25 in.)	<b>R</b>	39.5 to 40.5 mm (1.56 to 1.59 in.)
<b>H</b>	365 mm (14.37 in.)	<b>S</b>	140 mm (5.51 in.)
<b>I</b>	377.8 mm (14.87 in.)	<b>T</b>	260 mm (10.24 in.)
<b>J</b>	50.8 mm (2.00 in.)	<b>U</b>	99.5 to 100.5 mm (3.92 to 3.95 in.)
<b>K</b>	40 mm (1.57 in.)	<b>V</b>	45 mm (1.77 in.)

**Check and High Pressure Relief Valve Assembly Tool**

**Application**

- Use for readjusting relief valve pressure.

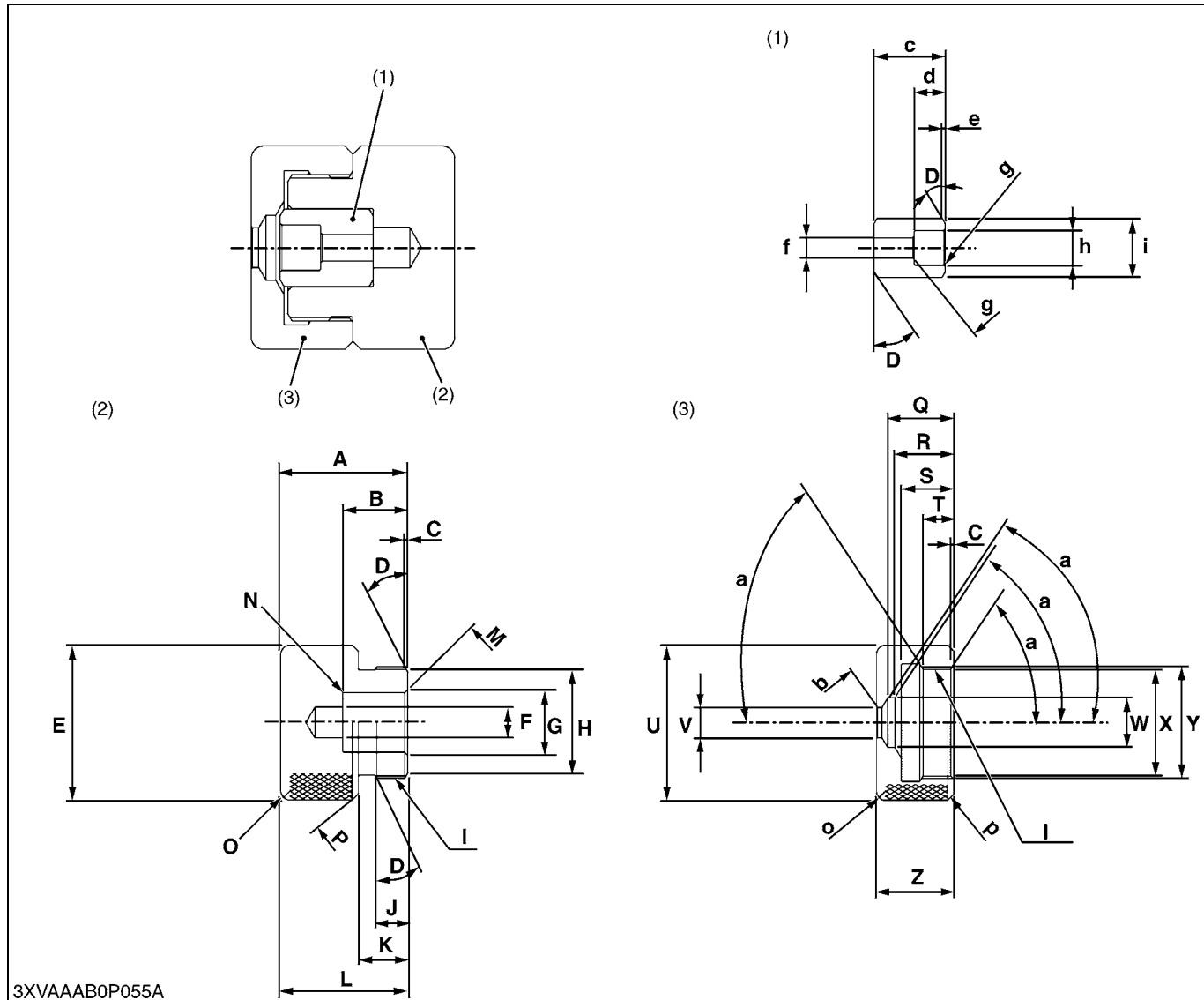

3XVAAABOP055A

<b>A</b>	30 mm (1.181 in.)	<b>N</b>	Chamfer 0.4 mm (0.157 in.)	<b>a</b>	1.05 rad (10 °)
<b>B</b>	21 mm (0.827 in.)	<b>O</b>	Chamfer 3 mm (0.118 in.)	<b>b</b>	Chamfer 0.3 mm (0.012 in.)
<b>C</b>	1 mm (0.039 in.)	<b>P</b>	Chamfer 2 mm (0.079 in.)	<b>c</b>	23 mm (0.906 in.)
<b>D</b>	0.52 rad (30 °)	<b>Q</b>	21.4 mm (0.843 in.)	<b>d</b>	10 mm (0.394 in.)
<b>E</b>	50 mm dia. (1.969 in. dia.)	<b>R</b>	19 mm (0.748 in.)	<b>e</b>	1 mm (0.039 in.)
<b>F</b>	10 mm dia. (0.394 in. dia.)	<b>S</b>	17 mm (0.669 in.)	<b>f</b>	6.5 mm (0.256 in.)
<b>G</b>	9.1 to 9.3 mm dia. (0.359 to 0.366 in. dia.)	<b>T</b>	10 mm (0.393 in.)	<b>g</b>	Chamfer 0.5 mm (0.020 in.)
<b>H</b>	34 mm dia. (1.336 in. dia.)	<b>U</b>	50 mm dia. (1.969 in. dia.)	<b>h</b>	11.1 to 11.3 mm (0.437 to 0.445 in.)
<b>I</b>	M36 × 1.5 mm Pitch	<b>V</b>	9.8 mm dia. (0.386 in. dia.)	<b>i</b>	18.8 to 19.0 mm (0.740 to 0.748 in.)
<b>J</b>	10 mm (0.394 in.)	<b>W</b>	16 mm dia. (0.629 in. dia.)		
<b>K</b>	16 mm (0.630 in.)	<b>X</b>	34.5 mm dia. (1.358 in. dia.)	<b>(1)</b>	Spacer
<b>L</b>	41 mm (1.614 in.)	<b>Y</b>	38 mm dia. (1.496 in. dia.)	<b>(2)</b>	Block
<b>M</b>	Chamfer 1 mm (0.039 in.)	<b>Z</b>	25 mm (0.984 in.)	<b>(3)</b>	Cap

9Y1210855GEG0080US0

### [3] SPECIAL TOOLS FOR LOADER

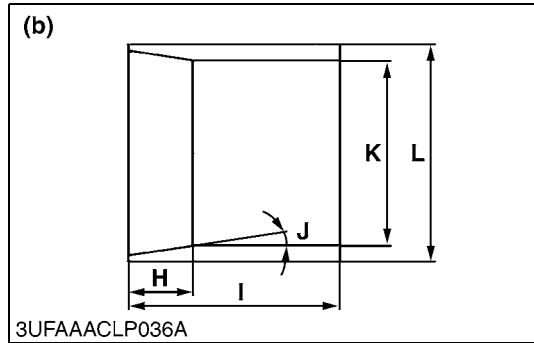
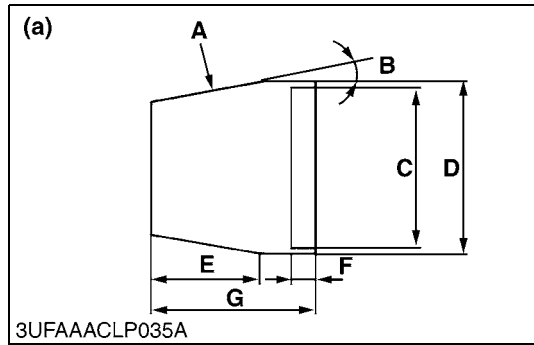

#### Sliding Jig and Correcting Jig

##### Application

- Use to install the O-ring and the piston seal.

	Boom cylinder (40 mm (1.57 in.))	Bucket cylinder (65 mm (2.56 in.))
A	80 √	
B	0.157 rad (9.0 °)	
C	40.18 mm dia. (1.582 in. dia.)	65.18 mm dia. (2.566 in. dia.)
D	41.18 mm dia. (1.621 in. dia.)	66.18 mm dia. (2.606 in. dia.)
E	42.0 mm (1.65 in.)	
F	10.0 mm (0.4 in.)	
G	58.5 mm (2.30 in.)	
H	14 mm (0.55 in.)	
I	35.0 mm (1.38 in.)	
J	0.122 rad (7 °)	
K	40.2 mm dia. (1.583 in. dia.)	65.2 mm dia. (2.567 in. dia.)
L	48.9 mm dia. (1.925 in. dia.)	73.9 mm dia. (2.909 in. dia.)

(a) Sliding Jig

(b) Correcting Jig

9Y1210855GEG0081US0

# 9. TIRES

## [1] TIRE PRESSURE

 **WARNING**

- Do not attempt to mount a tire on a rim. This should be done by a qualified person with the proper equipment.
- Always maintain the correct tire pressure.  
Do not inflate tires above the recommended pressure shown in the operator's manual.

**IMPORTANT**

- Do not use tires larger than specified.
- When you intend to mount different size of tires from equipped ones, consult your distributor about front drive gear ratio for detail.  
Excessive wear of tires may occur due to improper gear ratio.

**[BX1870D]**

	Tire sizes	Inflation pressure
Rear	24 × 12.00 – 12 Turf 24 × 12.00 – 12 Bar	100 kPa (1.0 kgf/cm <sup>2</sup> , 14 psi) 120 kPa (1.2 kgf/cm <sup>2</sup> , 17 psi)
Front	16 × 7.50 – 8 Turf 16 × 7.50 – 8 Bar	120 kPa (1.2 kgf/cm <sup>2</sup> , 17 psi) 150 kPa (1.5 kgf/cm <sup>2</sup> , 22 psi)

**[BX2370D and BX2670D]**

	Tire sizes	Inflation pressure
Rear	26 × 12.00 – 12 Turf 26 × 12.00 – 12 Bar 26 × 12.00 – 12 Ind.	100 kPa (1.0 kgf/cm <sup>2</sup> , 14 psi) 120 kPa (1.2 kgf/cm <sup>2</sup> , 17 psi) 120 kPa (1.2 kgf/cm <sup>2</sup> , 17 psi)
Front	18 × 8.50 – 10 Turf 18 × 8.50 – 10 Bar 18 × 8.50 – 10 Ind.	120 kPa (1.2 kgf/cm <sup>2</sup> , 17 psi) 150 kPa (1.5 kgf/cm <sup>2</sup> , 22 psi) 150 kPa (1.5 kgf/cm <sup>2</sup> , 22 psi)

Though the tire pressure is factory-set to the prescribed level, it naturally drops slowly in the course of time. Thus, check it everyday and inflate as necessary.

**NOTE**

- Maintain the maximum pressure in front tires, if using a front loader or when equipped with a full load of front weights.

9Y1210855GEG0082US0

## [2] WHEEL TREAD

### CAUTION

To avoid personal injury:

- Support tractor securely on stands before removing a wheel.
- Never operate tractor with a loose rim, wheel or axle.

9Y1210855GEG0083US0

### (1) Front Wheels

Front tread can not be adjusted.

#### ■ IMPORTANT

- Do not turn discs to obtain wider tread.

#### ■ NOTE

- Use the tapered bolts for wheels with beveled or tapered holes.

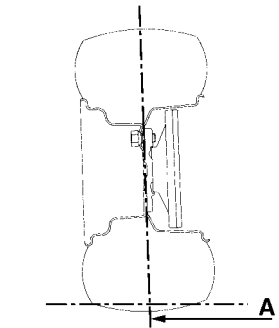
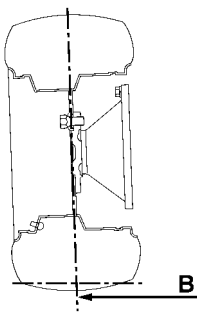
Models	BX1870D	BX2370D and BX2670D
Tire	16 × 7.50 – 8 Turf, 16 × 7.50 – 8 Bar	18 × 8.50 – 10 Turf, 18 × 8.50 – 10 Bar, 18 × 8.50 – 10 Ind.
Tread	 <p>3TAAAAF0P015A</p>	 <p>3TAAAAG0P025B</p>

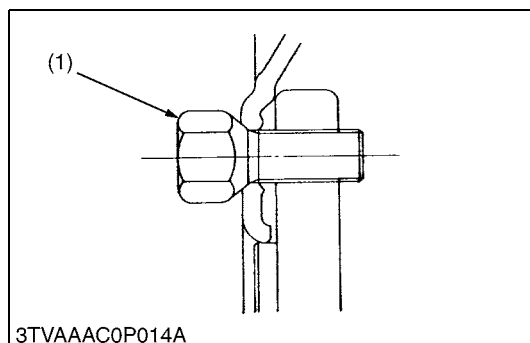

### CAUTION

- Before jacking up the tractor, park it on a firm and level ground and chock the rear wheels.
- Fix the front axle to keep it from swinging.
- Select jacks that with stand the machine weight and set them up at jack point (3).

Tightening torque	Front wheel	149.2 to 179.0 N·m 15.2 to 18.3 kgf·m 110 to 132 lbf·ft
-------------------	-------------	---

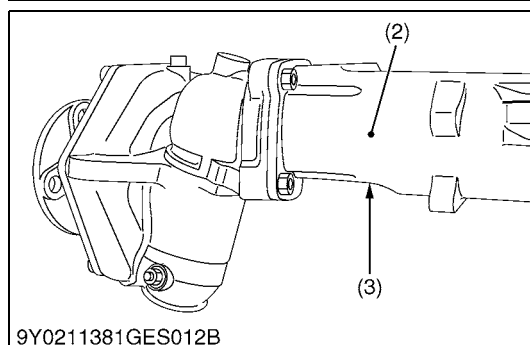

- (1) Wheel Mounting Screw
- (2) Front Axle Case
- (3) Jack Point

- A: 880 mm (34.6 in.)
- B: 910 mm (35.8 in.)

9Y1210855GEG0084US0

## (2) Rear Wheels

Rear tread can not be adjusted.

### ■ IMPORTANT

- Do not turn discs to obtain wider tread.
- Always attach tires as shown in the drawing.
- If not attached as illustrated, transmission parts may be damaged.
- When re-fitting or adjusting a wheel, tighten the bolts to the following torques then recheck after driving the tractor 200 m (200 yards) and thereafter daily check service.

### ■ NOTE

- Use the tapered bolts for wheels with beveled or tapered holes.

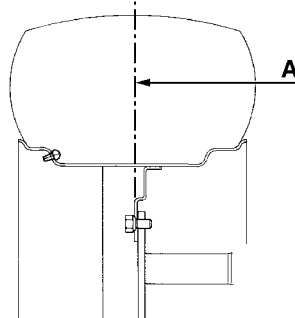
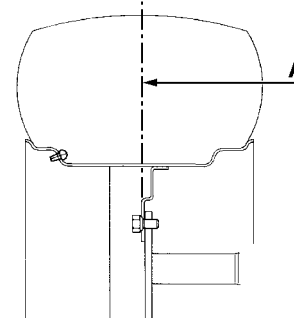
Models	BX1870D	BX2370D and BX2670D
Tire	16 × 7.50 – 8 Turf, 16 × 7.50 – 8 Bar	26 × 12.00 – 12 Turf, 26 × 12.00 – 12 Bar, 26 × 12.00 – 12 Ind.
Tread	 <p>3TAAAAG0P006B</p>	 <p>3TAAAAG0P006B</p>

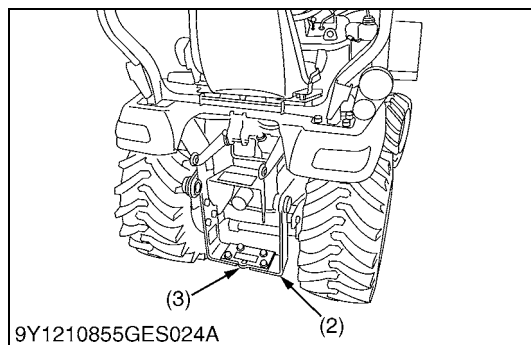
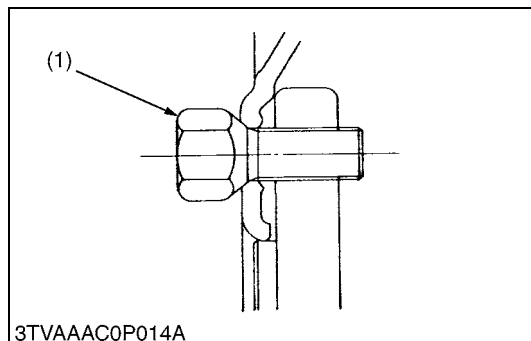

### ⚠ CAUTION

- Before jacking up the tractor, park it on a firm and level ground and chock the rear wheels.
- Fix the front axle to keep it from swinging.
- Select jacks that with stand the machine weight and set them up at jack point (3).

Tightening torque	Rear wheel	108.5 to 130.2 N·m 11.1 to 13.3 kgf·m 80 to 96 lbf·ft
-------------------	------------	---

- (1) Wheel Mounting Screw
- (2) Frame
- (3) Jack Point

A: 820 mm (32.2 in.)

9Y1210855GEG0085US0

### [3] BALLAST



**CAUTION**

- **Additional ballast will be needed for transporting heavy implements.**  
**When the implements is raised, drive slowly over rough ground, regardless of how much ballast is used.**
- **Do not fill the front wheels with liquid to maintain steering control.**

9Y1210855GEG0086US0

#### (1) Front Ballast

Add weights if needed for stability and improve traction.

Heavy pulling and heavy rear mounted implements tend to lift front wheels. Add enough ballast to maintain steering control and prevent tip over.

Remove weight when no longer needed.

9Y1210855GEG0087US0

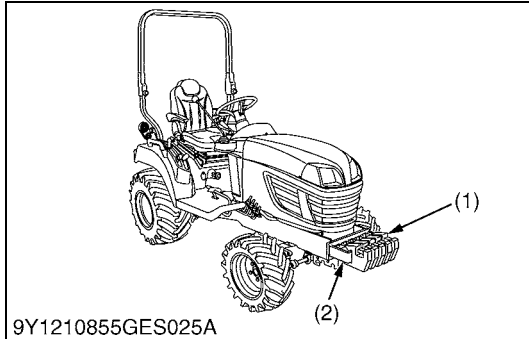

9Y1210855GES025A

#### Front End Weights (Option)

1. The front end weights can be attached to the bumper.  
 See your implement operator's manual for required number of weights.

■ **NOTE**

- **Besides the weight, a front weight bracket and mounting bolt kit(s) are required for mounting the weight.**

■ **IMPORTANT**

- **Do not overload tires.**
- **Add no more weight than indicated in chart.**

Maximum weight	Factory specification	125 kg 275 lbs
----------------	-----------------------	-------------------

(1) Front End Weights

(2) Front Weight Bracket (Option)

9Y1210855GEG0088US0



## (2) Rear Ballast

Add weights to rear wheels if needed to improve traction or for stability. The amount of rear ballast should be matched to job and the ballast should be removed when it is not needed.

The weight should be added to the tractor in the form of liquid ballast.

9Y1210855GEG0089US0

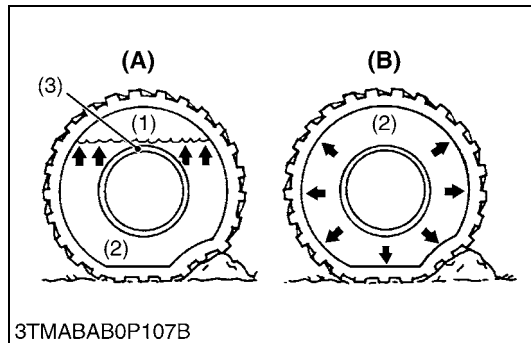

### Liquid Ballast in Rear Tires

1. Water and calcium chloride solution provides safe economical ballast. Used properly, it will not damage tires, tubes or rims.
2. The addition of calcium chloride is recommended to prevent the water from freezing.
3. Use of this method of weighting the wheels has the full approval of the tire companies.

#### ■ IMPORTANT

- Do not fill tires with water or solution more than 75 % of full capacity (to the level of valve stem at 12 o'clock position).
- To avoid damage of transmission, do not use rear wheel weights and liquid ballast at the same time.

Tire sizes	24 x 12.00 – 12 (BX1870D)	26 x 12.00 – 12 (BX2370D and BX2670D)
Slush free at -10 °C (14 °F) Solid at -30 °C (-22 °F) [Approx. 1 kg (2 lbs) CaCl <sub>2</sub> per 4 L (1 gal.) of water]	35 kg (77 lbs)	45 kg (99 lbs)
Slush free at -24 °C (-11 °F) Solid at -47 °C (-52 °F) [Approx. 1.5 kg (3.5 lbs) CaCl <sub>2</sub> per 4 L (1 gal.) of water]	38 kg (84 lbs)	50 kg (110 lbs)
Slush free at -47 °C (-53 °F) Solid at -52 °C (-62 °F) [Approx. 2.25 kg (5 lbs) CaCl <sub>2</sub> per 4 L (1 gal.) of water]	44 kg (97 lbs)	56 kg (123 lbs)

- (1) Air
- (2) Water
- (3) Valve Stem

- (A) Correct: 75 % Full Air  
Compresses Like A Cushion
- (B) Incorrect: 100 % Full  
Water Can Not Be Compressed

9Y1210855GEG0090US0

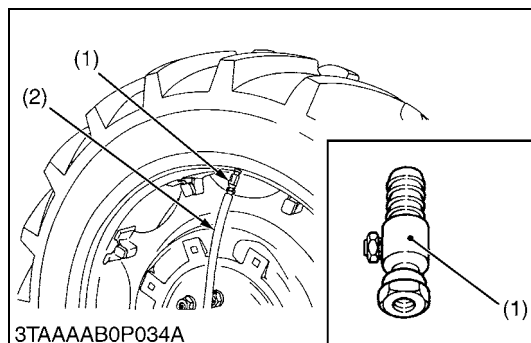

### Attaching Injector

1. Lift the rear tires off the ground.
2. Turn the tire so that the air valve is at the top.
3. Remove the air valve, and attach the injector. (Code No. 07916-52511)

- (1) Injector
- (2) Hose

9Y1210855GEG0091US0

# 10. IMPLEMENT LIMITATIONS

The KUBOTA Tractor has been thoroughly tested for proper performance with implements sold or approved by KUBOTA. Use with implements which are not sold or approved by KUBOTA and which exceed the maximum specifications listed below, or which are otherwise unfit for use with the KUBOTA Tractor may result in malfunctions or failures of the tractor, damage to other property and injury to the operator or others. [Any malfunctions or failures of the tractor resulting from use with improper implements are not covered by the warranty.]

WSM000001GEG0083US0

	Tread (max. width) with farm tires		Lower link end max. loading weight <b>W0</b>
	Front	Rear	
BX1870D	880 mm (34.6 in.)	820 mm (32.2 in.)	550 kg (1210 lbs)
BX2370D	910 mm (35.8 in.)		
BX2670D			

	Actual figures		
	Implement Weight <b>W1</b> and / or size	Max. Drawbar Load <b>W2</b>	Trailer loading weight <b>W3</b> Max. capacity
BX1870D	As in the following list (shown on the next page)	250 kg (550 lbs)	800 kg (1765 lbs)
BX2370D			
BX2670D			

Lower link end max. hydraulic lifting capacity **W0**

Implement weight **W1**: The implement's weight which can be put on the lower link

Max. drawbar load **W2**

Trailer loading weight **W3**: The max. loading weight for trailer (without trailer's weight)

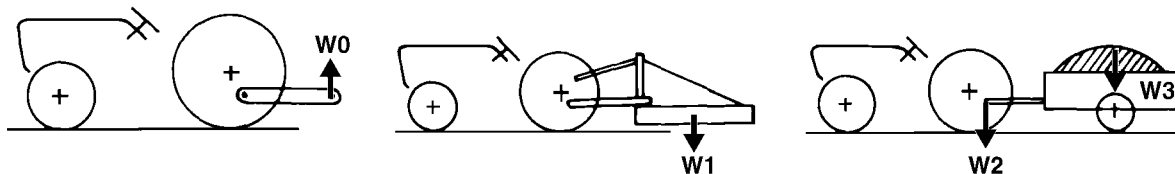

3TMABAB0P109A

**NOTE**

- Implement size may vary depending on soil operating conditions.
- Strictly follow the instructions outlined in the operator's manual of the mounted or trailed machinery or trailer, and do not operate the combination tractor - machine or tractor - trailer unless all instructions have been followed.

• Forestry Application

Following hazards exist;

- toppling trees, primarily in case a rear-mounted tree grab-crane is mounted at the rear of the tractor;
- penetrating objects in the operator's enclosure, primarily in case a winch is mounted at the rear of the tractor.

Optional equipments such as OPS (Operator Protective Structure), FOPS (Falling Object Protective Structure), etc. to deal with these hazards and other related hazards are not available for this tractor. Without such optional equipment use is limited to tractor specific applications like transport and stationary work.

9Y1210855GEG0092US0

	Implement	Remarks	BX1870D	BX2370D	BX2670D
Mower	Mid-Mount	Max. Cutting Width	1370 mm (54 in.)	1524 mm (60 in.)	
		Max. Weight	95 kg (210 lbs)	140 kg (309 lbs)	
	Rotary-Cutter (1 Blade)	Max. Cutting Width	1070 mm (42 in.)		
		Max. Weight	140 kg (300 lbs)		
	Rear-Mount (2 or 3 Blade)	Max. Cutting Width	1220 mm (48 in.)	1520 mm (60 in.)	
		Max. Weight	115 kg (250 lbs)	140 kg (300 lbs)	
	Flail Mower	Max. Cutting Width	1070 mm (42 in.)		
Sickle Bar	Max. Cutting Width	1220 mm (48 in.)			
Rotary Tiller	Max. Tilling Width	1070 mm (42 in.)			
	Max. Weight	170 kg (375 lbs)			
Bottom Plow	Max. Size	12 in. × 1	14 in. × 1		
Disc Plow	Max. Size	22 in. × 1			
Cultivator	Max. Width	1220 mm (48 in.) 1 Row			
Disc Harrow	Max. Harrowing Width	1220 mm (48 in.)	1370 mm (54 in.)		
	Max. Weight	120 kg (265 lbs)	140 kg (300 lbs)		
Sprayer	Max. Tank Capacity	150 L (40 U.S.gals, 33 Imp.gals)			
Front Blade	Max. Cutting Width	1370 mm (54 in.)	1520 mm (60 in.)		
	Sub Frame	Necessary			
Rear Blade	Max. Cutting Width	1370 mm (54 in.)	1520 mm (60 in.)		
	Sub Frame	140 kg (300 lbs)	160 kg (350 lbs)		
Front Loader	Max. Lifting Capacity	280 kg (617 lbs)*2	340 kg (750 lbs)*2		
	Max. Width	1220 mm (48 in.)			
Box Blade	Max. Lifting Capacity	1220 mm (48 in.)			
	Max. Weight	170 kg (375 lbs)			
Snow Blower (Front)	Max. Working Width	1270 mm (50 in.)			
	Max. Weight	160 kg (350 lbs)			
	Sub Frame	Necessary			
Post Hole Digger	Digging Depth	1140 mm (45 in.)			
Rotary Broom	Cleaning Width	1190 mm (47 in.)			
Trailer	Max. Load Capacity	800 kg (1765 lbs)			
	Max. Weight	1100 kg (2425 lbs)*1			

■ **NOTE**

- **Backhoe cannot be attached.**
- **Implement size may vary depending on soil operating conditions.**
- \*1 Reduce speed and trailer loads when operating in slippery conditions or when operating on slopes and utilize front wheel drive.
- \*2 The valve contains the weight of KUBOTA standard bucket.

9Y1210855GEG0093US0

# 1 ENGINE

# MECHANISM

## CONTENTS

1. LUBRICATING SYSTEM.....	1-M1
2. COOLING SYSTEM .....	1-M2
3. FUEL SYSTEM.....	1-M3

# 1. LUBRICATING SYSTEM

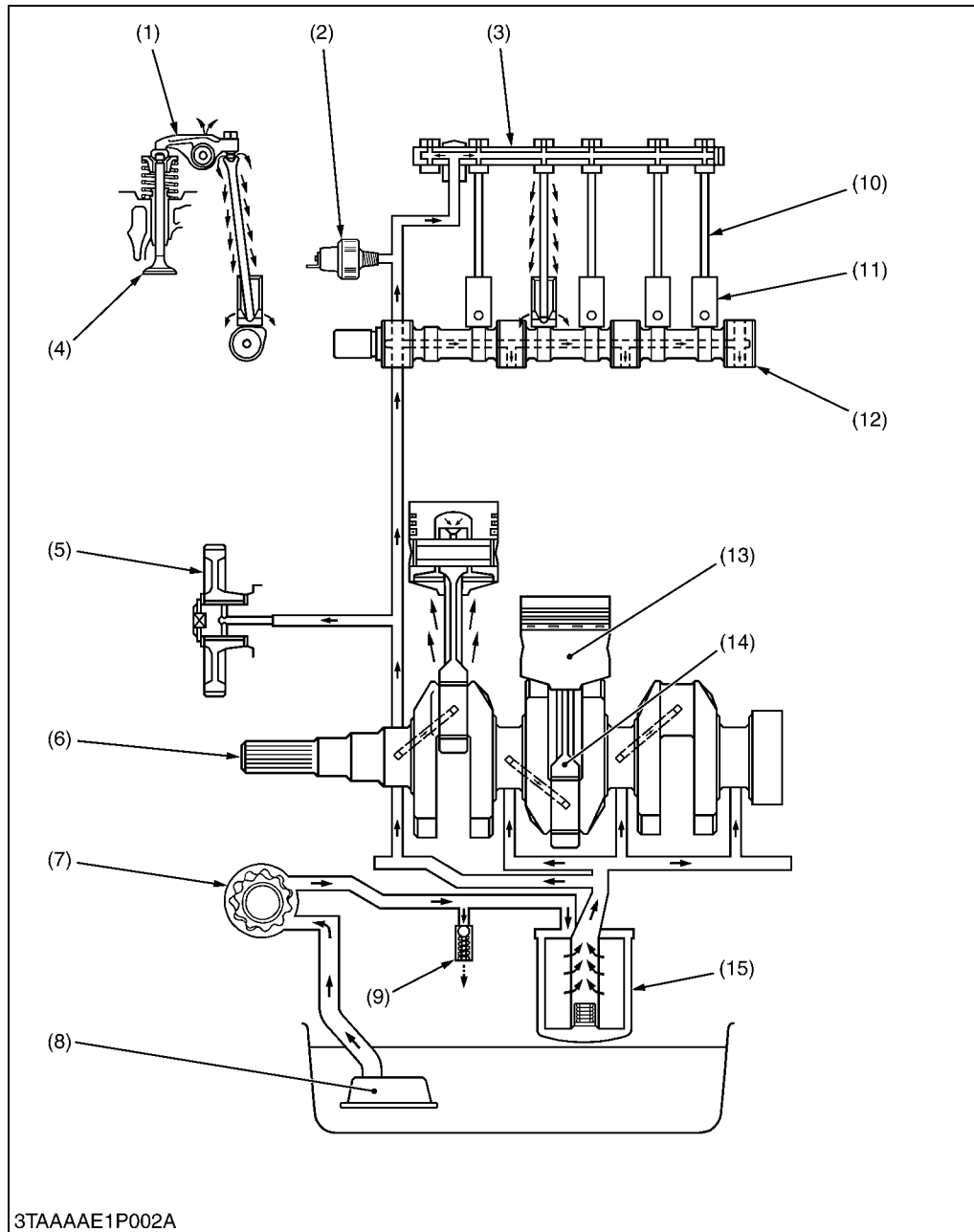

- (1) Rocker Arm
- (2) Oil Pressure Switch
- (3) Rocker Arm Shaft
- (4) Valve
- (5) Idle Gear
- (6) Crankshaft
- (7) Oil Pump
- (8) Oil Strainer
- (9) Relief Valve
- (10) Push Rod
- (11) Tappet
- (12) Camshaft
- (13) Piston
- (14) Connecting Rod
- (15) Oil Filter Cartridge

3TAAAE1P002A

This engine's lubricating system consists of oil strainer (8), oil pump (7), relief valve (9), oil filter cartridge (15) and oil pressure switch (2).

The oil pump sucks lubricating oil from the oil pan through the oil strainer and the oil flows down to the filter cartridge, where it is further filtered. Then the oil is forced to crankshaft (6), connecting rods (14), idle gear (5), camshaft (12) and rocker arm shaft (3) to lubricate each part.

Some part of oil, splashed by the crankshaft or leaking and dropping from gaps of each part, lubricates these parts: piston (13), cylinders, small ends or connecting rods, tappets (11), push rods (10), inlet and exhaust valves (4) and timing gears.

9Y1210855ENM0001US0

## 2. COOLING SYSTEM

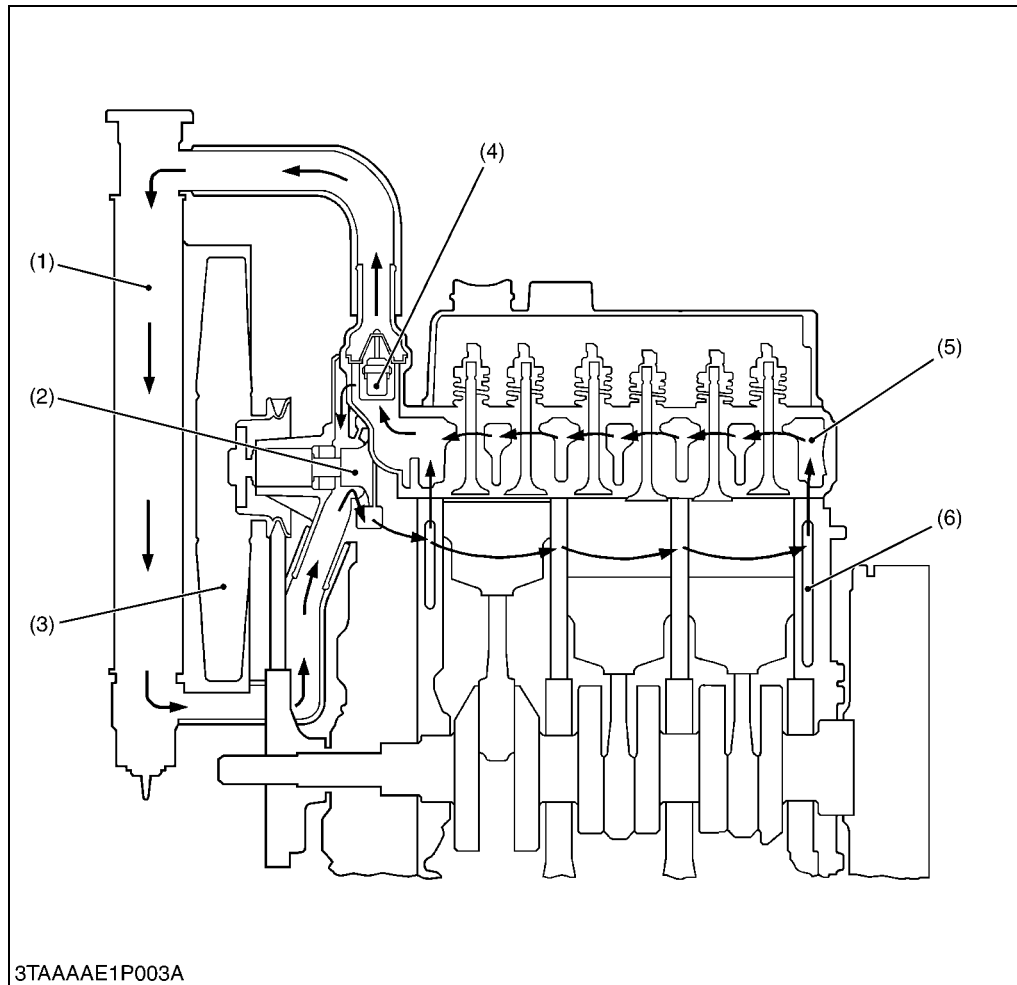

- (1) Radiator
- (2) Water Pump
- (3) Cooling Fan
- (4) Thermostat
- (5) Cylinder Head
- (6) Cylinder Head

The cooling system consists of a radiator (1), a centrifugal water pump (2), a cooling fan (3) and a thermostat (4). The coolant is cooled through the radiator core, and the cooling fan (3) set behind the radiator (1) pulls cooling air through the radiator core to improve cooling.

The water pump receives water from the radiator or from the cylinder head and force it into the cylinder block.

The thermostat opens or closes according to the water temperature. When the water temperature is high, the thermostat opens to allow the water to flow from the cylinder head to the radiator. When the water temperature is low, the thermostat close to flow the water only to the water pump.

9Y1210855ENM0002US0

### 3. FUEL SYSTEM

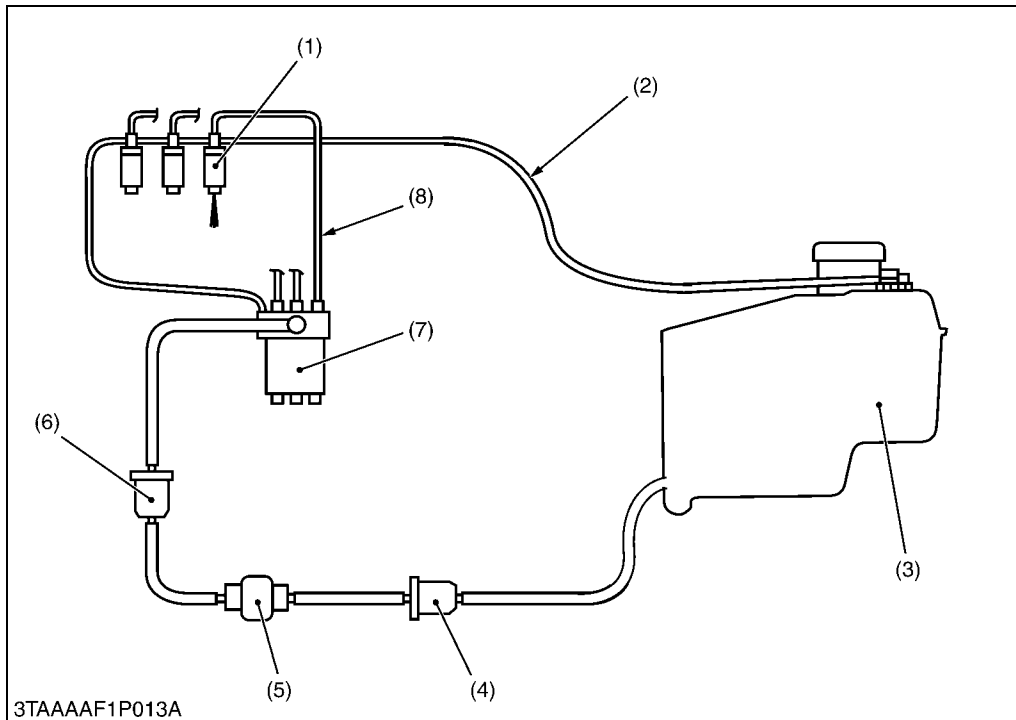

- (1) Injection Nozzle
- (2) Fuel Overflow Pipe
- (3) Fuel Tank
- (4) Fuel Filter
- (5) Fuel Feed Pump
- (6) Fuel Filter
- (7) Injection Pump
- (8) Injection Pipe

3TAAAF1P013A

Fuel from the fuel tank (3) passes through the fuel filter (4), and then enters the injection pump (7) after impurities such as dirt, water, etc. are removed.

The fuel pressurized by the injection pump to the opening pressure (13.7 to 14.7 MPa, 140 to 150 kgf/cm<sup>2</sup>, 1990 to 2133 psi), of the injection nozzle (1) is injected into the combustion chamber.

Part of the fuel fed to the injection nozzle (1) lubricates the moving parts of the needle valve inside the nozzle, then returns to the fuel tank through the fuel overflow pipe (2) from the upper part of the nozzle holder.

9Y1210855ENM0003US0



# SERVICING

## CONTENTS

1. TROUBLESHOOTING.....	1-S1
2. SERVICING SPECIFICATIONS.....	1-S4
[1] BX1870D (D722-E4) and BX2370D (D902-E4).....	1-S4
[2] BX2670D (D1005-E4).....	1-S9
3. TIGHTENING TORQUES.....	1-S15
4. CHECKING, DISASSEMBLING AND SERVICING.....	1-S17
[1] CHECKING AND ADJUSTING.....	1-S17
(1) Engine Body.....	1-S17
(2) Lubricating System.....	1-S19
(3) Cooling System.....	1-S20
(4) Fuel System.....	1-S22
[2] DISASSEMBLING AND ASSEMBLING.....	1-S26
(1) Separating Engine.....	1-S26
(2) Removing Outer Parts.....	1-S29
(3) Cylinder Head and Valves.....	1-S29
(4) Gear Case and Timing Gears.....	1-S33
(5) Piston and Connecting Rod.....	1-S37
(6) Flywheel and Crankshaft.....	1-S39
[3] SERVICING.....	1-S41
(1) Cylinder Head and Valves.....	1-S41
(2) Timing Gears, Camshaft and Governor Gear.....	1-S49
(3) Piston and Connecting Rod.....	1-S53
(4) Crankshaft.....	1-S57
(5) Cylinder.....	1-S65
(6) Oil Pump.....	1-S66
(7) Relief Valve Spring.....	1-S68

# 1. TROUBLESHOOTING

Symptom	Probable Cause	Solution	Reference Page
<b>Engine Does Not Start</b>	No fuel	Fill the fuel	G-9
	Air in the fuel system	Bleed	G-40
	Water in the fuel system	Change fuel and repair or replace fuel system	–
	Fuel line clogged	Clean	G-29
	Fuel filter clogged	Change	G-34
	Excessively high viscosity of fuel or engine oil at low temperature	Use specified fuel or engine oil	G-9
	Fuel with low cetane number	Use specified fuel	G-9
	Fuel leak due to loose injection pipe retaining nut	Tighten retaining nut	1-S30
	Incorrect injection timing	Adjust	1-S22
	Fuel camshaft worn	Replace	1-S36
	Injection nozzle clogged	Clean or replace	1-S30
	Injection pump malfunctioning	Replace	1-S35
	Seizure of crankshaft, camshaft, piston, cylinder or bearing	Repair or replace	1-S37, 1-S40
	Compression leak from cylinder	Replace head gasket, tighten cylinder head screw, glow plug and nozzle holder	1-S17, 1-S31
	Improper valve timing	Correct or replace timing gear	1-S36
	Piston ring and cylinder worn	Replace	1-S38
Excessive valve clearance	Adjust	1-S18	
<b>Starter Does Not Run</b>	Battery discharged	Charge	G-26
	Starter malfunctioning	Repair or replace	6-S28
	Main switch malfunctioning	Repair or replace	6-S9
	Safety switches malfunctioning	Adjust or replace	6-S12
	Wiring disconnected	Connect	–
<b>Engine Revolution Is Not Smooth</b>	Fuel filter clogged or dirty	Replace	G-34
	Air cleaner clogged	Clean or replace	G-28
	Fuel leak due to loose injection pipe retaining nut	Tighten retaining nut	1-S30
	Injection pump malfunctioning	Replace	1-S35
	Incorrect nozzle opening pressure	Adjust	1-S24
	Injection nozzle stuck or clogged	Repair or replace	1-S30
	Governor malfunctioning	Repair	1-S35
<b>Either White or Blue Exhaust Gas Is Observed</b>	Excessive engine oil	Reduce to specified level	G-21
	Piston ring and cylinder worn or stuck	Repair or replace	1-S38
	Incorrect injection timing	Adjust	1-S22
	Deficient compression	Check	1-S17

Symptom	Probable Cause	Solution	Reference Page
<b>Either Black or Dark Gray Exhaust Gas Is Observed</b>	Overload	Reduce the load	–
	Low grade fuel used	Use specified fuel	G-9
	Fuel filter clogged	Replace	G-34
	Air cleaner clogged	Clean or replace	G-28
	Deficient nozzle injection	Repair or replace nozzle	1-S30
<b>Deficient Output</b>	Incorrect injection timing	Adjust	1-S22
	Engine's moving parts seem to be seizing	Repair or replace	–
	Injection pump malfunctioning	Repair or replace	1-S35
	Deficient nozzle injection	Repair or replace nozzle	1-S30
	Compression leak	Replace head gasket, tighten cylinder head screws, glow plug and nozzle holder	1-S17, 1-S31
	Air cleaner dirty or clogged	Clean or replace	G-28
<b>Excessive Lubricant Oil Consumption</b>	Piston ring's gap facing the same direction	Shift ring gap direction	1-S37
	Oil ring worn or stuck	Replace	1-S38
	Piston ring groove worn	Replace piston	1-S38
	Valve stem and valve guide worn	Replace	1-S43
	Oil leaking due to damaged seals or packing	Replace	–
<b>Fuel Mixed into Lubricant Oil</b>	Injection pump's plunger worn	Repair or replace	1-S35
	Deficient nozzle injection	Repair or replace nozzle	1-S30
	Injection pump broken	Replace	1-S35
<b>Water Mixed into Lubricant Oil</b>	Head gasket damaged	Replace	1-S31
	Cylinder block or cylinder head flawed	Replace	–
<b>Low Oil Pressure</b>	Engine oil insufficient	Fill	G-9
	Oil strainer clogged	Clean	1-S33
	Oil filter clogged	Replace	G-21
	Relief valve stuck with dirt	Clean	1-S68
	Relief valve spring weaken or broken	Replace	1-S68
	Excessive oil clearance of crankshaft bearing	Replace	1-S40, 1-S62
	Excessive oil clearance of crankpin bearing	Replace	1-S40, 1-S58
	Excessive oil clearance of rocker arm	Replace	1-S31, 1-S47
	Oil passage clogged	Clean	–
	Different type of oil	Use specified type of oil	G-9
	Oil pump damaged	Repair or replace	1-S34

Symptom	Probable Cause	Solution	Reference Page
<b>High Oil Pressure</b>	Different type of oil	Use specified type of oil	G-9
	Relief valve damaged	Replace	1-S19, 1-S68
<b>Engine Overheated</b>	Engine oil insufficient	Fill	1-S26
	Fan belt broken or elongated	Replace or adjust	G-29
	Coolant insufficient	Fill	G-9
	Radiator net and radiator fin clogged with dust	Clean	–
	Inside of radiator corroded	Clean or replace	G-28
	Coolant flow route corroded	Clean or replace	–
	Radiator cap damaged	Replace	1-S21
	Overload running	Reduce the load	–
	Head gasket damaged	Replace	1-S31
	Incorrect injection timing	Adjust	1-S22
	Unsuitable fuel used	Use specified fuel	G-9
<b>Battery Quickly Discharged</b>	Battery electrolyte insufficient	Fill distilled water and charge	G-26
	Fan belt slips	Adjust belt tension or replace	G-29
	Wiring disconnected	Connect	–
	Rectifier damaged	Replace	–
	Alternator damaged	Replace	–
	Battery damaged	Replace	–

9Y1210855ENS0001US0

## 2. SERVICING SPECIFICATIONS

### [1] BX1870D (D722-E4) and BX2370D (D902-E4)

#### ENGINE BODY

Item		Factory Specification	Allowable Limit
Valve Clearance (Cold)		0.145 to 0.185 mm 0.00571 to 0.00728 in.	–
Compression Pressure <b>[BX1870D (D722-E4)]</b>		2.85 to 3.23 MPa 29.0 to 33.0 kgf/cm <sup>2</sup> 413 to 469 psi	2.26 MPa 23.0 kgf/cm <sup>2</sup> 327 psi
• Difference among Cylinders		–	10 % or less
Compression Pressure <b>[BX2370D (D902-E4)]</b>		3.53 to 4.02 MPa 36.0 to 41.0 kgf/cm <sup>2</sup> 512 to 583 psi	2.55 MPa 26.0 kgf/cm <sup>2</sup> 370 psi
• Difference among Cylinders		–	10 % or less
Top Clearance		0.55 to 0.70 mm 0.022 to 0.027 in.	–
Cylinder Head Surface	Flatness	–	0.05 mm 0.002 in.
Valve Recessing	Intake and Exhaust	0.10 (protrusion) to 0.10 (recessing) mm 0.0039 (protrusion) to 0.0039 (recessing) in.	0.30 (recessing) mm 0.012 (recessing) in
Valve Stem to Valve Guide	Clearance	0.030 to 0.057 mm 0.0012 to 0.0022 in.	0.10 mm 0.0039 in.
• Valve Stem	O.D.	5.968 to 5.980 mm 0.2350 to 0.2354 in.	–
• Valve Guide	I.D.	6.010 to 6.025 mm 0.2367 to 0.2372 in.	–
Valve Face	Angle (Intake)	0.79 rad 45 °	–
	Angle (Exhaust)	0.79 rad 45 °	–
Valve Seat	Angle (Intake)	0.79 rad 45 °	–
	Angle (Exhaust)	0.79 rad 45 °	–
	Width	2.12 mm 0.0835 in.	–
Valve Spring	Free Length	31.3 to 31.8 mm 1.24 to 1.25 in.	28.4 mm 1.12 in.
	Tilt	–	1.2 mm 0.047 in.
	Setting Load	65 N / 27.0 mm 6.6 kgf / 27.0 mm 15 lbf / 1.06 in.	55 N / 27.0 mm 5.6 kgf / 27.0 mm 12 lbf / 1.06 in.

Item		Factory Specification	Allowable Limit
Rocker Arm Shaft to Rocker Arm  • Rocker Arm Shaft  • Rocker Arm	Clearance	0.016 to 0.045 mm 0.00063 to 0.0017 in.	0.15 mm 0.0059 in.
	O.D.	10.473 to 10.484 mm 0.41233 to 0.41275 in.	–
	I.D.	10.500 to 10.518 mm 0.41339 to 0.41409 in.	–
Push Rod	Alignment	–	0.25 mm 0.0098 in.
Tappet to Tappet Guide  • Tappet  • Tappet Guide	Clearance	0.016 to 0.052 mm 0.00063 to 0.0020 in.	0.10 mm 0.0039 in.
	O.D.	17.966 to 17.984 mm 0.70733 to 0.70803 in.	–
	I.D.	18.000 to 18.018 mm 0.70867 to 0.70937 in.	–
Timing Gear • Crank Gear to Idle Gear  • Idle Gear 1 to Cam Gear  • Idle Gear 1 to Injection Pump Gear  • Crank Gear to Oil Pump Drive Gear	Backlash	0.0430 to 0.124 mm 0.00170 to 0.00488 in.	0.15 mm 0.0059 in.
	Backlash	0.0470 to 0.123 mm 0.00185 to 0.00484 in.	0.15 mm 0.0059 in.
	Backlash	0.0460 to 0.124 mm 0.00182 to 0.00488 in.	0.15 mm 0.0059 in.
	Backlash	0.0410 to 0.123 mm 0.00162 to 0.00484 in.	0.15 mm 0.0059 in.
Idle Gear Shaft to Gear Bushing • Idle Gear 1  • Idle Gear Bushing  • Idle Gear Shaft 1	Clearance	0.020 to 0.084 mm 0.00079 to 0.0033 in.	0.10 mm 0.0039 in.
	I.D.	20.000 to 20.051 mm 0.78741 to 0.78940 in.	–
	O.D.	19.967 to 19.980 mm 0.78611 to 0.78661 in.	–
Idle Gear • Idle Gear 1	Side Clearance	0.20 to 0.51 mm 0.0079 to 0.020 in.	0.80 mm 0.031 in.
Camshaft	Side Clearance	0.15 to 0.31 mm 0.0059 to 0.012 in.	0.50 mm 0.020 in.
	Alignment	–	0.01 mm 0.0004 in.
Cam Height	Intake	26.88 mm 1.058 in.	26.83 mm 1.056 in.
	Exhaust	26.88 mm 1.058 in.	26.83 mm 1.056 in.

Item		Factory Specification	Allowable Limit
Camshaft Journal to Cylinder Block Bore	Clearance	0.050 to 0.091 mm 0.0020 to 0.0035 in.	0.15 mm 0.0059 in.
	• Camshaft Journal	O.D. 32.934 to 32.950 mm 1.2967 to 1.2972 in.	–
	• Cylinder Block Bore	I.D. 33.000 to 33.025 mm 1.2993 to 1.3001 in.	–
Piston Pin Bore	I.D.	20.000 to 20.013 mm 0.78741 to 0.78791 in.	20.05 mm 0.7894 in.
Piston Pin to Small End Bushing	Clearance	0.015 to 0.075 mm 0.0059 to 0.0029 in.	0.15 mm 0.0059 in.
	• Piston Pin	O.D. 20.002 to 20.011 mm 0.78748 to 0.78783 in.	–
	• Small End Bushing	I.D. 20.025 to 20.040 mm 0.78839 to 0.78897 in.	–
Piston Ring Gap <b>[BX1870D (D722-E4)]</b>	Top Ring	0.15 to 0.30 mm 0.0059 to 0.011 in.	1.2 mm 0.0472 in.
	Second Ring	0.30 to 0.45 mm 0.012 to 0.017 in.	1.25 mm 0.0492 in.
	Oil Ring	0.15 to 0.30 mm 0.0059 to 0.011 in.	1.2 mm 0.0472 in.
Piston Ring Gap <b>[BX2370D (D902-E4)]</b>	Top Ring	0.20 to 0.35 mm 0.0079 to 0.013 in.	1.25 mm 0.0492 in.
	Second Ring	0.35 to 0.50 mm 0.014 to 0.019 in.	1.25 mm 0.0492 in.
	Oil Ring	0.20 to 0.35 mm 0.0079 to 0.013 in.	1.25 mm 0.0492 in.
Piston Ring to Piston Ring Groove	• Second Ring	Clearance 0.0900 to 0.0120 mm 0.00355 to 0.00472 in.	0.15 mm 0.0059 in.
	• Oil Ring	Clearance 0.040 to 0.080 mm 0.0016 to 0.0031 in.	0.15 mm 0.0059 in.
Connecting Rod	Alignment	–	0.05 mm 0.002 in.
Crankshaft	Alignment	–	0.02 mm 0.0008 in.
Crankshaft to Crankshaft Bearing 1 <b>[BX1870D (D722-E4)]</b>	Oil Clearance	0.0340 to 0.114 mm 0.00134 to 0.00448 in.	0.20 mm 0.0079 in.
	• Crankshaft	O.D. 39.934 to 39.950 mm 1.5722 to 1.5728 in.	–
	• Crankshaft Bearing 1	I.D. 39.984 to 40.040 mm 1.5742 to 1.5763 in.	–

Item		Factory Specification	Allowable Limit
Crankshaft to Crankshaft Bearing 1 <b>[BX2370D (D902-E4)]</b>	Oil Clearance	0.0340 to 0.106 mm 0.00134 to 0.00417 in.	0.20 mm 0.0079 in.
	• Crankshaft	O.D. 43.934 to 43.950 mm 1.7297 to 1.7303 in.	–
	• Crankshaft Bearing 1	I.D. 43.984 to 44.040 mm 1.7317 to 1.7338 in.	–
Crankshaft Bearing 1	Dimension (A)	0 to 0.3 mm 0 to 0.01 in.	–
Crankshaft to Crankshaft Bearing 2	Oil Clearance	0.028 to 0.059 mm 0.0011 to 0.0023 in.	0.20 mm 0.0079 in.
	• Crankshaft Journal	O.D. 43.934 to 43.950 mm 1.7297 to 1.7303 in.	–
	• Crankshaft Bearing 2	I.D. 43.978 to 43.993 mm 1.7315 to 1.7320 in.	–
Crankshaft to Crankshaft Bearing 3 <b>[BX1870D (D722-E4)]</b>	Oil Clearance	0.028 to 0.059 mm 0.0011 to 0.0023 in.	0.20 mm 0.0079 in.
	• Crankshaft Journal	O.D. 39.934 to 39.950 mm 1.5722 to 1.5728 in.	–
	• Crankshaft Bearing 3	I.D. 39.978 to 39.993 mm 1.5740 to 1.5745 in.	–
Crankshaft to Crankshaft Bearing 3 <b>[BX2370D (D902-E4)]</b>	Oil Clearance	0.028 to 0.059 mm 0.0011 to 0.0023 in.	0.20 mm 0.0079 in.
	• Crankshaft Journal	O.D. 43.934 to 43.950 mm 1.7297 to 1.7303 in.	–
	• Crankshaft Bearing 3	I.D. 43.978 to 43.993 mm 1.7315 to 1.7320.	–
Crankpin to Crankpin Bearing	Oil Clearance	0.020 to 0.051 mm 0.00079 to 0.0020 in.	0.15 mm 0.0059 in.
	• Crankpin	O.D. 33.959 to 33.975 mm 1.3370 to 1.3375 in.	–
	• Crankshaft Bearing	I.D. 33.995 to 34.010 mm 1.3384 to 1.3389 in.	–
Crankshaft	Side Clearance	0.15 to 0.31 mm 0.0059 to 0.012 in.	0.50 mm 0.020 in.
Cylinder Liner I.D. <b>[BX1870D (D722-E4)]</b>	I.D.	67.000 to 67.019 mm 2.6378 to 2.6385 in.	67.150 mm 2.6437 in.
	<b>[BX2370D (D902-E4)]</b>	I.D. 72.000 to 72.019 mm 2.8347 to 2.8353 in.	72.150 mm 2.8406 in.



Item	Factory Specification	Allowable Limit
Cylinder (Oversized) [BX1870D (D722-E4)]	67.250 to 67.269 mm 2.6477 to 2.6483 in.	67.400 mm 2.6535 in.
[BX2370D (D902-E4)]	72.250 to 72.269 mm 2.8445 to 2.8452 in.	72.400 mm 2.8504 in.

**LUBRICATING SYSTEM**

Item	Factory Specification	Allowable Limit
Engine Oil Pressure	At Idle Speed More than 49 kPa 0.50 kgf/cm <sup>2</sup> 7.1 psi	–
	At Rated Speed 197 to 441 kPa 2.00 to 4.50 kgf/cm <sup>2</sup> 28.5 to 64.0 psi	147 kPa 1.50 kgf/cm <sup>2</sup> 21.3 psi
Inner Rotor to Outer Rotor	Clearance 0.030 to 0.14 mm 0.0012 to 0.0055 in.	–
Outer Rotor to Pump Body	Clearance 0.070 to 0.15 mm 0.0028 to 0.0059 in.	–
Inner Rotor to Cover	Clearance 0.0750 to 0.135 mm 0.00296 to 0.00531 in.	–
Relief Valve Spring	Length 32 mm 1.26 in.	28 mm 1.10 in.

**COOLING SYSTEM**

Item	Factory Specification	Allowable Limit
Fan Belt	Tension 7.0 to 9.0 mm / 98 N 0.28 to 0.35 in. / 98 N (10 kgf, 22 lbf)	–
Thermostat	Valve Opening Temperature (At Beginning) 69.5 to 72.5 °C 157.1 to 162.5 °F	–
	Valve Opening Temperature (Opened Completely) 85 °C 185 °F	–
Radiator Cap	Pressure Falling Time 10 seconds or more 88 → 59 kPa 0.90 → 0.60 kgf/cm <sup>2</sup> 13 → 8.5 psi	–
Radiator	Water Leakage Test Pressure No leak at specified pressure	–

**FUEL SYSTEM**

Item		Factory Specification	Allowable Limit
Injection Pump <b>[BX1870D (D722-E4)]</b>	Injection Timing	0.3186 to 0.3447 rad (18.25 to 19.75 °) before T.D.C	–
	<b>[BX2370D (D902-E4)]</b>	Injection Timing	0.3360 to 0.3621 rad (19.25 to 20.75 °) before T.D.C.
Pump Element	Fuel Tightness	–	13.73 MPa 140.0 kgf/cm <sup>2</sup> 1991 psi
Delivery Valve	Fuel Tightness	10 seconds 13.73 → 12.75 MPa 140.0 → 130.0 kgf/cm <sup>2</sup> 1991 → 1849 psi	5 seconds 13.73 → 12.75 MPa 140.0 → 130.0 kgf/cm <sup>2</sup> 1991 → 1849 psi
Injection Nozzle	Injection Pressure	13.73 to 14.70 MPa 140.0 to 150.0 kgf/cm <sup>2</sup> 1992 to 2133 psi	–
Injection Nozzle Valve Seat	Valve Seat Tightness	When the pressure is 12.75 MPa (130.0 kgf/cm <sup>2</sup> , 1849 psi), the valve seat must be fuel tightness.	–

9Y1210855ENS0002US0

**[2] BX2670D (D1005-E4)**

**ENGINE BODY**

Item		Factory Specification	Allowable Limit
Valve Clearance (Cold)		0.145 to 0.185 mm 0.00571 to 0.00728 in.	–
Compression Pressure		3.73 to 4.11 MPa 38.0 to 42.0 kgf/cm <sup>2</sup> 541 to 597 psi	2.26 MPa 23.0 kgf/cm <sup>2</sup> 327 psi
• Difference among Cylinders		–	10 % or less
Top Clearance		0.55 to 0.75 mm 0.022 to 0.029 in.	–
Cylinder Head Surface	Flatness	–	0.05 mm 0.002 in.
Valve Recessing	Intake and Exhaust	0.050 (protrusion) to 0.25 (recessing) mm 0.0020 (protrusion) to 0.0098 (recessing) in.	0.40 (recessing) mm 0.016 (recessing) in.
Valve Stem to Valve Guide	Clearance	0.035 to 0.065 mm 0.0014 to 0.0025 in.	0.10 mm 0.0039 in.
• Valve Stem	O.D.	6.960 to 6.975 mm 0.2741 to 0.2746 in.	–
• Valve Guide	I.D.	7.010 to 7.025 mm 0.2760 to 0.2765 in.	–

Item		Factory Specification	Allowable Limit
Valve Face	Angle (Intake)	1.0 rad 60 °	–
	Angle (Exhaust)	0.79 rad 45 °	–
Valve Seat	Angle (Intake)	1.0 rad 60 °	–
	Angle (Exhaust)	0.79 rad 45 °	–
	Width	2.12 mm 0.0835 in.	–
Valve Spring	Free Length	37.0 to 37.5 mm 1.46 to 1.47 in.	36.5 mm 1.44 in.
	Tilt	–	1.0 mm 0.039 in.
	Setting Load	117.4 N / 31.0 mm 11.97 kgf / 31.0 mm 26.39 lbf / 1.22 in.	100.0 N / 31.0 mm 10.20 kgf / 31.0 mm 22.48 lbf / 1.22 in.
Rocker Arm Shaft to Rocker Arm  • Rocker Arm Shaft  • Rocker Arm	Clearance	0.016 to 0.045 mm 0.00063 to 0.0017 in.	0.10 mm 0.0039 in.
	O.D.	11.973 to 11.984 mm 0.47138 to 0.47181 in.	–
	I.D.	12.000 to 12.018 mm 0.47244 to 0.47314 in.	–
Push Rod	Alignment	–	0.25 mm 0.0098 in.
Tappet to Tappet Guide  • Tappet  • Tappet Guide	Clearance	0.020 to 0.062 mm 0.00079 to 0.0024 in.	0.07 mm 0.003 in.
	O.D.	19.959 to 19.980 mm 0.78579 to 0.78661 in.	–
	I.D.	20.000 to 20.021 mm 0.78740 to 0.78822 in.	–
Timing Gear • Crank Gear to Idle Gear 1  • Idle Gear 1 to Cam Gear  • Idle Gear 1 to Injection Pump Gear	Backlash	0.0320 to 0.115 mm 0.00126 to 0.00452 in.	0.15 mm 0.0059 in.
	Backlash	0.0360 to 0.114 mm 0.00142 to 0.00448 in.	0.15 mm 0.0059 in.
	Backlash	0.0340 to 0.116 mm 0.00134 to 0.00456 in.	0.15 mm 0.0059 in.
Governor Gear • Governor Gear to Injection Pump Gear (Fuel Cam Gear)	Backlash	0.0300 to 0.117 mm 0.00119 to 0.00460 in.	0.15 mm 0.0059 in.

Item		Factory Specification	Allowable Limit
Idle Gear Shaft to Gear Bushing • Idle Gear 1  • Idle Gear Bushing  • Idle Gear Shaft 1	Clearance	0.020 to 0.054 mm 0.00079 to 0.0021 in.	0.10 mm 0.0039 in.
	I.D.	26.000 to 26.021 mm 1.0237 to 1.0244 in.	–
	O.D.	25.967 to 25.980 mm 1.0224 to 1.0228 in.	–
Idle Gear • Idle Gear 1	Side Clearance	0.20 to 0.51 mm 0.0079 to 0.020 in.	0.80 mm 0.031 in.
Camshaft	Side Clearance	0.070 to 0.22 mm 0.0028 to 0.0086 in.	0.30 mm 0.012 in.
	Alignment	–	0.01 mm 0.0004 in.
Cam Height	Intake	28.80 mm 1.134 in.	28.75 mm 1.132 in.
	Exhaust	29.00 mm 1.142 in.	28.95 mm 1.140 in.
Camshaft Journal to Cylinder Block Bore  • Camshaft Journal  • Cylinder Block Bore	Clearance	0.050 to 0.091 mm 0.0020 to 0.0035 in.	0.15 mm 0.0059 in.
	O.D.	35.934 to 35.950 mm 1.4148 to 1.4153 in.	–
	I.D.	36.000 to 36.025 mm 1.4174 to 1.4183 in.	–
Piston Pin Bore	I.D.	22.000 to 22.013 mm 0.86615 to 0.86665 in.	22.03 mm 0.8673 in.
Piston Pin to Small End Bushing  • Piston Pin  • Small End Bushing	Clearance	0.014 to 0.038 mm 0.00056 to 0.0014 in.	0.15 mm 0.0059 in.
	O.D.	22.002 to 22.011 mm 0.86622 to 0.86657 in.	–
	I.D.	22.025 to 22.040 mm 0.86713 to 0.86771 in.	–
Piston Ring Gap	Top Ring	0.30 to 0.45 mm 0.012 to 0.017 in.	1.25 mm 0.0492 in.
	Second Ring	0.30 to 0.45 mm 0.012 to 0.017 in.	1.25 mm 0.0492 in.
	Oil Ring	0.25 to 0.40 mm 0.0098 to 0.015 in.	1.25 mm 0.0492 in.
Piston Ring to Piston Ring Groove • Second Ring  • Oil Ring	Clearance	0.0850 to 0.112 mm 0.00335 to 0.00440 in.	0.2 mm 0.008 in.
	Clearance	0.020 to 0.060 mm 0.00079 to 0.0023 in.	0.15 mm 0.0059 in.
Connecting Rod	Alignment	–	0.05 mm 0.002 in.

Item		Factory Specification	Allowable Limit
Crankshaft	Alignment	–	0.02 mm 0.0008 in.
Crankshaft to Crankshaft Bearing 1	Oil Clearance	0.0340 to 0.114 mm 0.00134 to 0.00448 in.	0.20 mm 0.0079 in.
• Crankshaft	O.D.	47.934 to 47.950 mm 1.8872 to 1.8877 in.	–
• Crankshaft Bearing 1	I.D.	47.984 to 48.048 mm 1.8892 to 1.8916 in.	–
Crankshaft Bearing 1	Dimension (A)	0 to 0.3 mm 0 to 0.01 in.	–
Crankshaft to Crankshaft Bearing 2	Oil Clearance	0.034 to 0.095 mm 0.0014 to 0.0037 in.	0.20 mm 0.0079 in.
• Crankshaft Journal	O.D.	47.934 to 47.950 mm 1.8872 to 1.8877 in.	–
• Crankshaft Bearing 2	I.D.	47.984 to 48.029 mm 1.8892 to 1.8909 in.	–
Crankshaft to Crankshaft Bearing 3	Oil Clearance	0.034 to 0.098 mm 0.0014 to 0.0038 in.	0.20 mm 0.0079 in.
• Crankshaft Journal	O.D.	51.921 to 51.940 mm 2.0442 to 2.0448 in.	–
• Crankshaft Bearing 3	I.D.	51.974 to 52.019 mm 2.0463 to 2.0479 in.	–
Crankpin to Crankpin Bearing	Oil Clearance	0.029 to 0.091 mm 0.0012 to 0.0035 in.	0.20 mm 0.0079 in.
• Crankpin	O.D.	39.959 to 39.975 mm 1.5732 to 1.5738 in.	–
• Crankshaft Bearing	I.D.	40.040 to 40.050 mm 1.5764 to 1.5767 in.	–
Crankshaft	Side Clearance	0.15 to 0.31 mm 0.0059 to 0.012 in.	0.50 mm 0.020 in.
Cylinder Liner I.D.		76.000 to 76.019 mm 2.9922 to 2.9928 in.	76.15 mm 2.998 in.
Cylinder (Oversized)		76.500 to 76.519 mm 3.0119 to 3.0125 in.	76.65 mm 3.018 in.

**LUBRICATING SYSTEM**

Item		Factory Specification	Allowable Limit
Engine Oil Pressure	At Idle Speed	More than 49 kPa 0.50 kgf/cm <sup>2</sup> 7.1 psi	–
	At Rated Speed	197 to 441 kPa 2.00 to 4.50 kgf/cm <sup>2</sup> 28.5 to 64.0 psi	147 kPa 1.50 kgf/cm <sup>2</sup> 21.3 psi
Inner Rotor to Outer Rotor	Clearance	0.060 to 0.18 mm 0.0024 to 0.0071 in.	–
Outer Rotor to Pump Body	Clearance	0.100 to 0.180 mm 0.00394 to 0.00708 in.	–
Inner Rotor to Cover	Clearance	0.025 to 0.075 mm 0.00099 to 0.0029 in.	–
Relief Valve Spring	Length	32 mm 1.26 in.	28 mm 1.10 in.

**COOLING SYSTEM**

Item		Factory Specification	Allowable Limit
Fan Belt	Tension	7.0 to 9.0 mm / 98 N 0.28 to 0.35 in. / 98 N (10 kgf, 22 lbf)	–
Thermostat	Valve Opening Temperature (At Beginning)	69.5 to 72.5 °C 157.1 to 162.5 °F	–
	Valve Opening Temperature (Opened Completely)	85 °C 185 °F	–
Radiator Cap	Pressure Falling Time	10 seconds or more 88 → 59 kPa 0.90 → 0.60 kgf/cm <sup>2</sup> 13 → 8.5 psi	–
Radiator	Water Leakage Test Pressure	No leak at specified pressure	–

**FUEL SYSTEM**

Item		Factory Specification	Allowable Limit
Injection Pump	Injection Timing	0.3360 to 0.3621 rad (19.25 to 20.75 °) before T.D.C.	–
Pump Element	Fuel Tightness	–	13.73 MPa 140.0 kgf/cm <sup>2</sup> 1991 psi
Delivery Valve	Fuel Tightness	10 seconds 13.73 → 12.75 MPa 140.0 → 130.0 kgf/cm <sup>2</sup> 1991 → 1849 psi	5 seconds 13.73 → 12.75 MPa 140.0 → 130.0 kgf/cm <sup>2</sup> 1991 → 1849 psi
Injection Nozzle	Injection Pressure	13.73 to 14.70 MPa 140.0 to 150.0 kgf/cm <sup>2</sup> 1991 to 2133 psi	–
Injection Nozzle Valve Seat	Valve Seat Tightness	When the pressure is 12.75 MPa (130.0 kgf/cm <sup>2</sup> , 1849 psi), the valve seat must be fuel tightness.	–

9Y1210855ENS0003US0

### 3. TIGHTENING TORQUES

Tightening torques of screws, bolts and nuts on the table below are especially specified.  
 (Tractor section for general use screws, bolts and nuts: Refer to "5. TIGHTENING TORQUES" on page G-13.)

**Tractor Section**

Item	N·m	kgf·m	lbf·ft
Front coupling mounting bolt	24 to 27	2.4 to 2.8	18 to 20
Engine mounting nut	24 to 27	2.4 to 2.8	18 to 20
Cushion mounting nut	24 to 27	2.4 to 2.8	18 to 20
Engine support mounting screw	48 to 55	4.9 to 5.7	36 to 41

**Engine Section**

Item	Dimension × Pitch	N·m	kgf·m	lbf·ft
Cylinder head cover screw [BX1870D (D722-E4) and BX2370D (D902-E4)]	M6 × 1.0	9.81 to 11.2	1.00 to 1.15	7.24 to 8.31
Cylinder head cover screw [BX2670D (D1005-E4)]	M6 × 1.0	7 to 8	0.7 to 0.9	5 to 6
Cylinder head screw [BX1870D (D722-E4) and BX2370D (D902-E4)]	M8 × 1.25	38 to 42	3.8 to 4.3	28 to 31
Cylinder head screw [BX2670D (D1005-E4)]	M8 × 1.25	64 to 68	6.5 to 7.0	47 to 50
*Main bearing case screw 1 [BX1870D (D722-E4) and BX2370D (D902-E4)]	M6 × 1.0	13 to 15	1.3 to 1.6	9.4 to 11
*Main bearing case screw 1 [BX2670D (D1005-E4)]	M7 × 1.0	30 to 34	3.0 to 3.5	22 to 25
*Main bearing case screw 2 [BX1870D (D722-E4) and BX2370D (D902-E4)]	M7 × 1.0	27 to 30	2.7 to 3.1	20 to 22
*Main bearing case screw 2 [BX2670D (D1005-E4)]	M8 × 1.25	49 to 53	5.0 to 5.5	37 to 39
*Flywheel screw	M10 × 1.25	54 to 58	5.5 to 6.0	40 to 43
*Connecting rod screw [BX1870D (D722-E4) and BX2370D (D902-E4)]	M7 × 0.75	27 to 30	2.7 to 3.1	20 to 22
*Connecting rod screw [BX2670D (D1005-E4)]	M7 × 0.75	42 to 46	4.2 to 4.7	31 to 33
*Rocker arm bracket screw [BX1870D (D722-E4) and BX2370D (D902-E4)]	M6 × 1.0	9.81 to 11.2	1.00 to 1.15	7.24 to 8.31
*Rocker arm bracket nut [BX2670D (D1005-E4)]	M7 × 1.0	22 to 26	2.2 to 2.7	16 to 19
*Fan drive pulley screw [BX1870D (D722-E4) and BX2370D (D902-E4)]	M12 × 1.5	118 to 127	12.0 to 13.0	86.8 to 94.0
*Fan drive pulley screw [BX2670D (D1005-E4)]	M14 × 1.5	236 to 245	24.0 to 25.0	174 to 180
Bearing case cover mounting screw	M6 × 1.0	9.81 to 11.2	1.00 to 1.15	7.24 to 8.31
Glow plug	M8 × 1.0	7.9 to 14	0.80 to 1.5	5.8 to 10



Item	Dimension × Pitch	N-m	kgf-m	lbf-ft
Nozzle holder assembly	M20 × 1.5	49 to 68	5.0 to 7.0	37 to 50
Nozzle holder	–	35 to 39	3.5 to 4.0	26 to 28
Oil pressure switch	PT 1/8	15 to 19	1.5 to 2.0	11 to 14
Injection pipe retaining nut	M12 × 1.5	25 to 34	2.5 to 3.5	18 to 25
Overflow pipe retaining nut	M12 × 1.5	20 to 24	2.0 to 2.5	15 to 18
Drain plug with copper gasket	M12 × 1.25	33 to 37	3.3 to 3.8	24 to 27
Oil filter joint	–	40 to 49	4.0 to 5.0	29 to 36

■ **NOTE**

- In removing and applying the bolts and nuts marked with "\*", a pneumatic wrench or similar pneumatic tool, if employed, must be used with enough care not to get them seized.
- For \* marked screws, bolts and nuts on the table, apply engine oil to their threads and seats before tightening.
- The letter "M" in Size × Pitch means that the screw, bolt or nut dimension stands for metric. The size is the nominal outside diameter in mm of the threads. The pitch is the nominal distance in mm between two threads.

9Y1210855ENS0004US0

# 4. CHECKING, DISASSEMBLING AND SERVICING

## [1] CHECKING AND ADJUSTING

### (1) Engine Body



#### Compression Pressure

1. Run the engine until it is warmed up.
2. Stop the engine.
3. Remove the air cleaner, the muffler and all glow plugs (or nozzles).
4. Set a compression tester with the adaptor to the glow plug hole (or nozzle hole).  
Nozzle hole: Adaptor **H** (07909-31231)  
Glow plug hole: Adaptor **L** (07909-31301)
5. Disconnect the connector of engine stop solenoid and keep the engine stop position (non-injection). Then, run the engine with the starter and measure the compression pressure.
6. Repeat steps 4 and 5 for each cylinder.
7. If the measurement is below the allowable limit, apply a small amount of oil to the cylinder wall through the glow plug hole (or nozzle hole) and measure the compression pressure again.
8. If the compression pressure is still less than the allowable limit, check the top clearance, valve clearance and cylinder head.
9. If the compression pressure increases after applying oil, check the cylinder wall and piston rings.

#### ■ NOTE

- Check the compression pressure with the specified valve clearance.
- Always use a fully charged battery for performing this test.
- Variances in cylinder compression values should be under 10 %.

#### [BX1870D (D722-E4)]

Compression pressure	Factory specification	2.85 to 3.23 MPa 29.0 to 33.0 kgf/cm <sup>2</sup> 413 to 469 psi
	Allowable limit	2.26 MPa 23.0 kgf/cm <sup>2</sup> 327 psi

#### [BX2370D (D902-E4)]

Compression pressure	Factory specification	3.53 to 4.02 MPa 36.0 to 41.0 kgf/cm <sup>2</sup> 512 to 583 psi
	Allowable limit	2.55 MPa 26.0 kgf/cm <sup>2</sup> 370 psi

#### [BX2670D (D1005-E4)]

Compression pressure	Factory specification	3.73 to 4.11 MPa 38.0 to 42.0 kgf/cm <sup>2</sup> 541 to 597 psi
	Allowable limit	2.26 MPa 23.0 kgf/cm <sup>2</sup> 327 psi

9Y1210855ENS0005US0

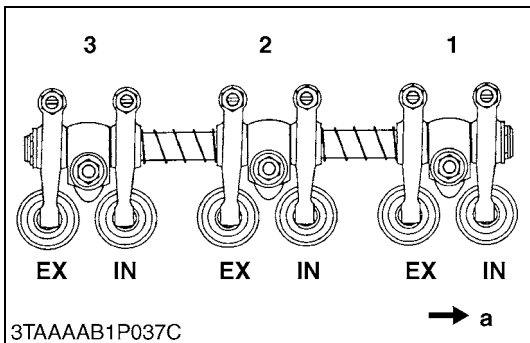
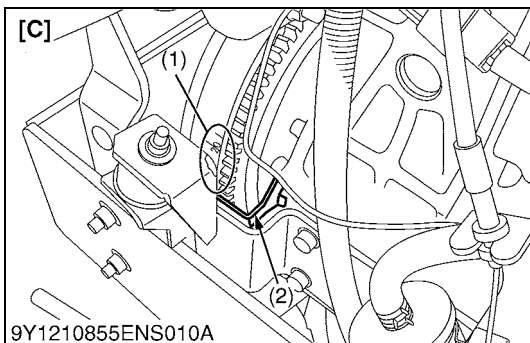
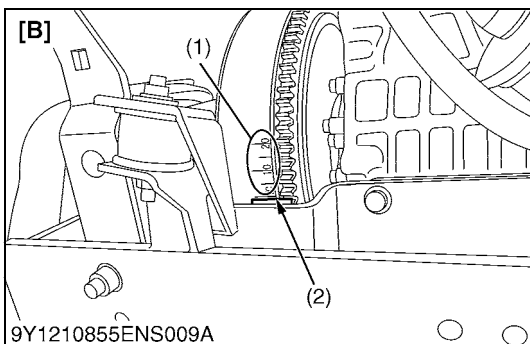
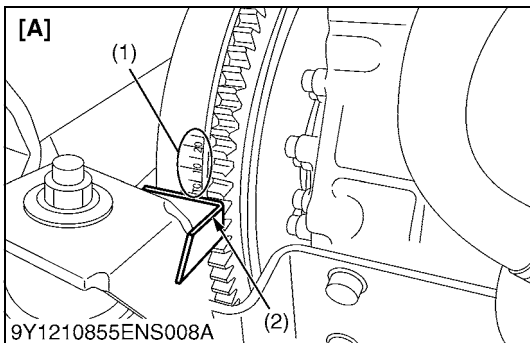
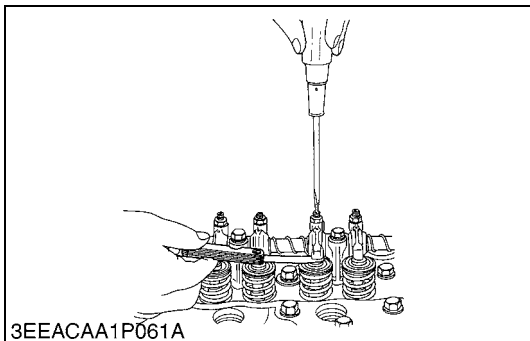

### Checking Valve Clearance

■ **IMPORTANT**

• **Valve clearance must be checked and adjusted when engine is cold.**

1. Remove the cylinder head cover and the glow plugs.
2. Align the "1TC" mark at "1TC" and "Timing Line" (1) on the flywheel and alignment mark (2) on the rear end plate so that the No. 1 piston comes to the compression top dead center.
3. Check the following valve clearance marked with "★" using a feeler gauge.
4. If the clearance is not within the factory specifications, adjust with the adjusting screw.
5. Then turn the flywheel 6.28 rad (360 °), and align the "1TC" mark at "1TC" and "Timing Line" (1) on the flywheel and alignment mark (2) on the rear end plate so that the No. 1 piston comes to the overlap position.
6. Check the following valve clearance marked with "☆" using a feeler gauge.
7. If the clearance is not within the factory specifications, adjust with the adjusting screw.

Adjustable cylinder location of piston	Number of cylinders Valve arrangement	
	Intake valve	Exhaust valve
No. 1	★	★
No. 2	☆	★
No. 3	★	☆

Valve clearance marked with "★" can be adjusted.

Intake and exhaust valve clearance (cold)	Factory specification	0.145 to 0.185 mm 0.00571 to 0.00728 in.
---	-----------------------	---

■ **NOTE**

- **The sequence of cylinder numbers is given as No. 1, No. 2 and No. 3 starting from the gear case side.**
- **After adjusting the valve clearance, secure the adjusting screw with the lock nut.**

- (1) "1TC" and "Timing Line"
- (2) Alignment Mark

- a: Gear Case Side
- [A] BX1870D (D722-E4)
- [B] BX2370D (D902-E4)
- [C] BX2670D (D1005-E4)

9Y1210855ENS0006US0

## (2) Lubricating System



### Engine Oil Pressure

1. Remove the engine oil pressure switch, and set an oil pressure tester.
2. Start the engine. After warming up, measure the oil pressure of both idling and rated speeds.
3. If the oil pressure is less than the allowable limit, check the following.
  - Engine oil insufficient
  - Oil pump damaged
  - Oil strainer clogged
  - Oil filter cartridge clogged
  - Oil gallery clogged
  - Excessive oil clearance
  - Foreign matter in the relief valve
  - Relief valve spring length (Refer to 1-S68.)

Engine oil pressure	At idle speed	Factory specification	More than 49 kPa 0.50 kgf/cm <sup>2</sup> 7.1 psi
	At rated speed	Factory specification	197 to 441 kPa 2.00 to 4.50 kgf/cm <sup>2</sup> 28.5 to 64.0 psi
		Allowable limit	147 kPa 1.50 kgf/cm <sup>2</sup> 21.3 psi

### **(When reassembling**

- After checking the engine oil pressure, tighten the engine oil pressure switch to the specified torque.

Tightening torque	Oil pressure switch	15 to 19 N·m 1.5 to 2.0 kgf·m 11 to 14 lbf·ft
-------------------	---------------------	---

9Y1210855ENS0007US0

### (3) Cooling System

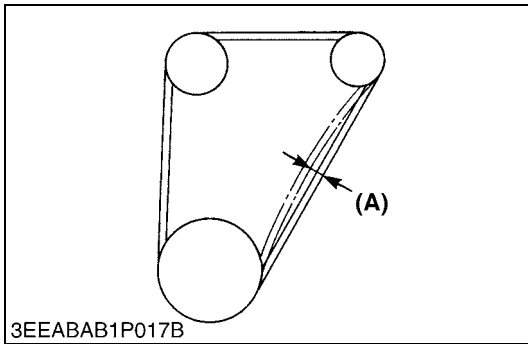

#### Fan Belt Tension

1. Measure the deflection **(A)**, depressing the belt halfway between the fan drive pulley and alternator pulley at specified force 98 N (10 kgf, 22 lbf).
2. If the measurement is not within the factory specifications, loosen the alternator mounting screws and relocate the alternator to adjust.

Deflection <b>(A)</b>	Factory specification	7.0 to 9.0 mm 0.28 to 0.35 in.
-----------------------	-----------------------	-----------------------------------

**(A) Deflection**

9Y1210855ENS0009US0

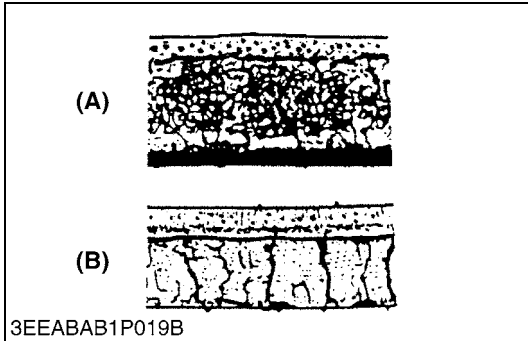

#### Fan Belt Damage and Wear

1. Check the fan belt for damage.
2. If the fan belt is damaged, replace it.
3. Check if the fan belt is worn and sunk in the pulley groove.
4. If the fan belt is nearly worn out and deeply sunk in the pulley groove, replace it.

**(A) Good**

**(B) Bad**

9Y1210855ENS0010US0

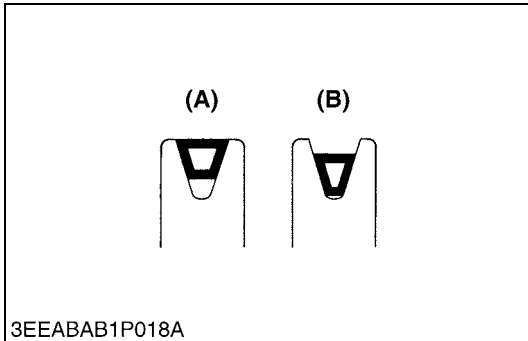

**CAUTION**

- When removing the radiator cap, wait at least ten minutes after the engine has stopped and cooled down. Otherwise, hot water may gush out, scalding nearby people.

9Y1210855ENS0011US0

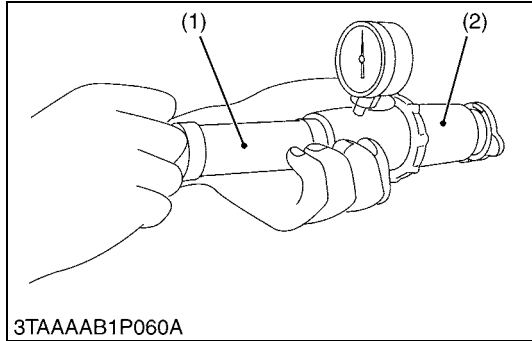

**Radiator Cap Air Leakage**

1. Set a radiator tester (1) and an adaptor (2) on the radiator cap.
2. Apply the specified pressure 88 kPa (0.90 kgf/cm<sup>2</sup>, 13 psi), and measure the time for the pressure to fall to 59 kPa (0.60 kgf/cm<sup>2</sup>, 8.5 psi).
3. If the measurement is less than the factory specification, replace the radiator cap.

Pressure falling time	Factory specification	More than 10 seconds for pressure fall 88 → 59 kPa (0.90 → 0.60 kgf/cm <sup>2</sup> , 13 → 8.5 psi)
-----------------------	-----------------------	---

(1) Radiator Tester

(2) Adaptor

9Y1210855ENS0012US0

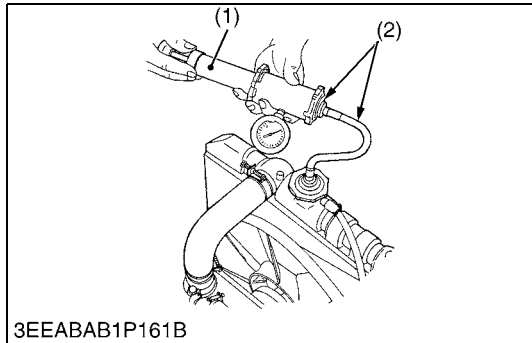

**Radiator Water Leakage**

1. Pour a specified amount of water into the radiator.
2. Set a radiator tester (1) and an adaptor (2) and raise the water pressure to the specified pressure.
3. Check the radiator for water leaks.
4. For water leak from the pinhole, repair with the radiator cement. When water leak is excessive, replace the radiator.

Radiator water leakage test pressure	Factory specification	No leak at specified pressure
--------------------------------------	-----------------------	-------------------------------

**NOTE**

- The pressure of the leak test is different from each radiator specification. Thus, do the leak test, refer to the test pressure of each radiator specification.

(1) Radiator Tester

(2) Adaptor

9Y1210855ENS0013US0

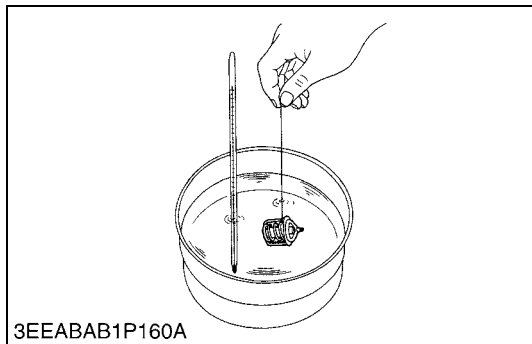

**Thermostat Valve Opening Temperature**

1. Suspend the thermostat in the water by a string with its end inserted between the valve and seat.
2. Heating the water gradually, read the temperature when the valve opens and leaves the string.
3. Continue heating and read the temperature when the valve opens approx. 8 mm (0.3 in.).
4. If the measurement is not within the factory specifications, replace the thermostat.

Thermostat's valve opening temperature	Factory specification	69.5 to 72.5 °C 157.1 to 162.5 °F
Temperature at which thermostat completely opens	Factory specification	85 °C 185 °F

9Y1210855ENS0014US0

### (4) Fuel System

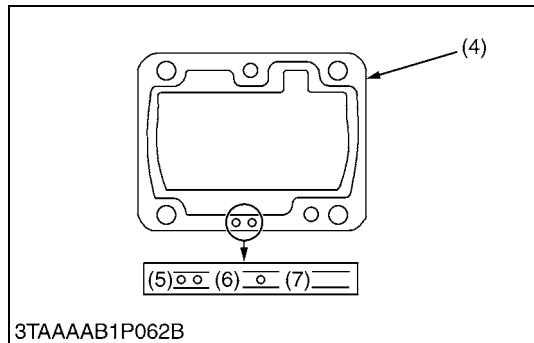
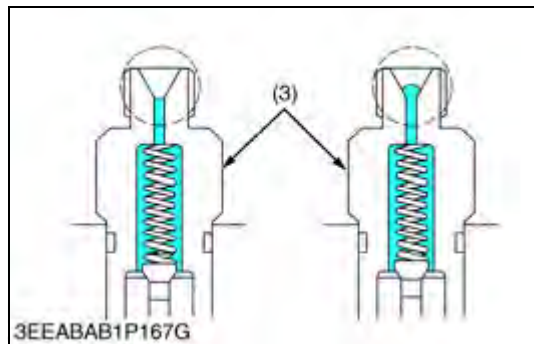
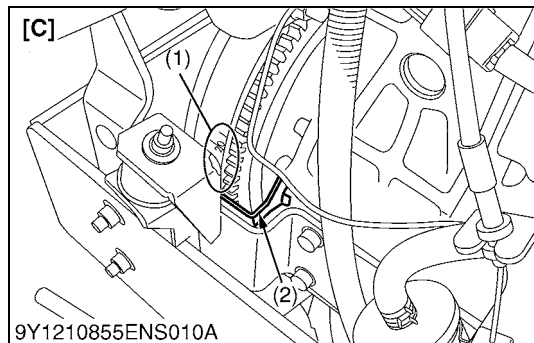
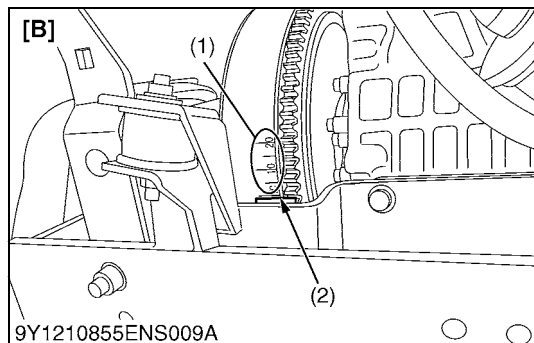
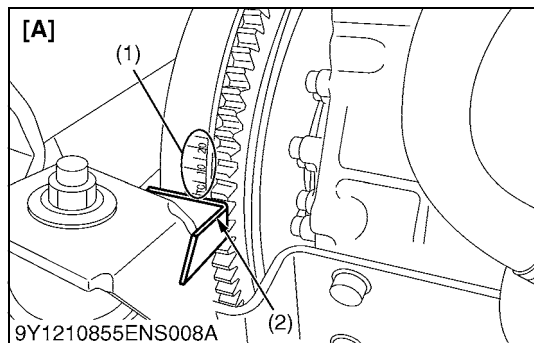

#### Injection Timing

1. Remove the injection pipes.
2. Remove the engine stop solenoid.
3. Turn the flywheel counterclockwise (viewed from flywheel side) until the fuel fills up to the hole of the delivery valve holder (3) for No. 1 cylinder.
4. After the fuel fills up to the hole of the delivery valve holder for No. 1 cylinder, turn back (clockwise) the flywheel around 1.6 rad (90 °).
5. Turn the flywheel counterclockwise to set at around 0.44 rad (25 °) before T.D.C..
6. Slowly turn the flywheel counterclockwise and stop turning when the fuel begins to come up, to get the present injection timing.
7. Check to see the degree on flywheel.  
The flywheel has mark "1TC", "10" and "20" for the crank angle before the top dead center of No. 1 cylinder.
8. If injection timing is out of adjustment, readjust the timing with shims.

#### [BX1870D (D722-E4)]

Injection timing	Factory specification	0.3186 to 0.3447 rad (18.25 to 19.75 °) before T.D.C.
------------------	-----------------------	---

#### [BX2370D (D902-E4) and BX2670D (D1005-E4)]

Injection timing	Factory specification	0.3360 to 0.3621 rad (19.25 to 20.75 °) before T.D.C.
------------------	-----------------------	---

#### NOTE

- The liquid gasket is not required for assembling.
- Shims are available in thickness of 0.20 mm (0.0079 in.), 0.25 mm (0.0098 in.), 0.30 mm (0.012 in.) and 0.175 mm (0.00689 in.). Combine these shims for adjustments.
- Addition or reduction of shim (0.05 mm, 0.002 in.) delays or advances the injection timing by approx. 0.009 rad (0.5 °).
- In disassembling and replacing the injection pump, be sure to use the same number of new shims with the same thickness.
- The 0.175 mm thick shim is coated only on the lower face. Therefore, do not use the 0.175 mm thick shim as the top shim of the combination (injection pump side), because this can cause oil leakage.

- |                                     |                                       |
|-------------------------------------|---------------------------------------|
| (1) "1TC" and "Timing Line"         | (6) One-hole: 0.25 mm (0.0098 in.)    |
| (2) Alignment Mark                  | (7) Without Hole: 0.30 mm (0.012 in.) |
| (3) Delivery Valve Holder           |                                       |
| (4) Shim (Soft Metal Gasket Shim)   | [A] BX1870D (D722-E4)                 |
| (5) Two-holes: 0.20 mm (0.0079 in.) | [B] BX2370D (D902-E4)                 |
| Two-holes: 0.175 mm (0.00689 in.)   | [C] BX2670D (D1005-E4)                |

9Y1210855ENS0015U0

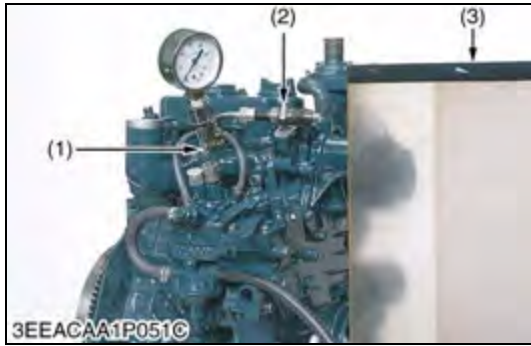

**Fuel Tightness of Pump Element**

1. Remove the engine stop solenoid.
2. Remove the injection pipes and glow plugs.
3. Install the injection pump pressure tester to the injection pump.
4. Install the injection nozzle (2) jetted with the proper injection pressure to the injection pump pressure tester (1). (Refer to the photo.)
5. Set the speed control lever to the maximum speed position.
6. Run the starter to increase the pressure.
7. If the pressure can not reach the allowable limit, replace the pump with new one or repair with a Kubota-authorized pump service shop.

Fuel tightness of pump element	Allowable limit	13.73 MPa 140.0 kgf/cm <sup>2</sup> 1991 psi
--------------------------------	-----------------	--

**NOTE**

- **Never try to disassemble the injection pump assembly. For repairs, you are strongly requested to contact a Kubota-authorized pump service shop.**

- (1) Injection Pump Pressure Tester      (3) Protection Cover for Jetted Fuel  
(2) Injection Nozzle

9Y1210855ENS0016US0

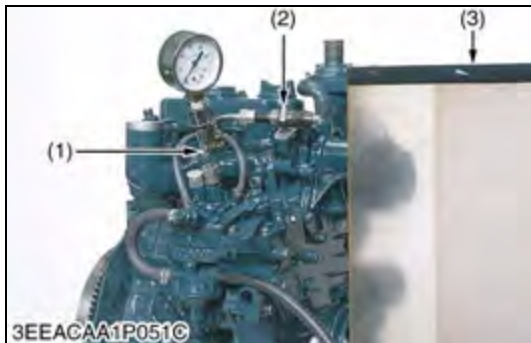

**Fuel Tightness of Delivery Valve**

1. Remove the engine stop solenoid.
2. Remove the injection pipes and glow plugs.
3. Set a pressure tester to the fuel injection pump.
4. Install the injection nozzle (2) jetted with the proper injection pressure to the injection pump pressure tester (1).
5. Run the starter to increase the pressure.
6. Stop the starter when the fuel jets from the injection nozzle. After that, turn the flywheel by the hand and raise the pressure to approx. 13.73 MPa (140.0 kgf/cm<sup>2</sup>, 1991 psi).
7. Now turn the flywheel back about half a turn (to keep the plunger free). Keep the flywheel at this position and clock the time taken for the pressure to drop from 13.73 to 12.75 MPa (from 140.0 to 130.0 kgf/cm<sup>2</sup>, from 1991 to 1849 psi).
8. Measure the time needed to decrease the pressure from 13.73 to 12.75 MPa (140.0 to 130.0 kgf/cm<sup>2</sup>, 1991 to 1849 psi).
9. If the measurement is less than allowable limit, replace the pump with new one or repair with a Kubota-authorized pump service shop.

Fuel tightness of delivery valve	Factory specification	10 seconds 13.73 → 12.75 MPa 140.0 → 130.0 kgf/cm <sup>2</sup> 1991 → 1849 psi
	Allowable limit	5 seconds 13.73 → 12.75 MPa 140.0 → 130.0 kgf/cm <sup>2</sup> 1991 → 1849 psi

**NOTE**

- **Never try to disassemble the injection pump assembly. For repairs, you are strongly requested to contact a Kubota-authorized pump service shop.**

- (1) Injection Pump Pressure Tester      (3) Protection Cover for Jetted Fuel  
(2) Injection Nozzle

9Y1210855ENS0017US0



**CAUTION**

- Check the nozzle injection pressure and condition after you make sure that there is nobody standing in the direction the fume goes. If the fume from the nozzle directly contacts the human body, cells may be destroyed and blood poisoning may be caused.

9Y1210855ENS0018US0

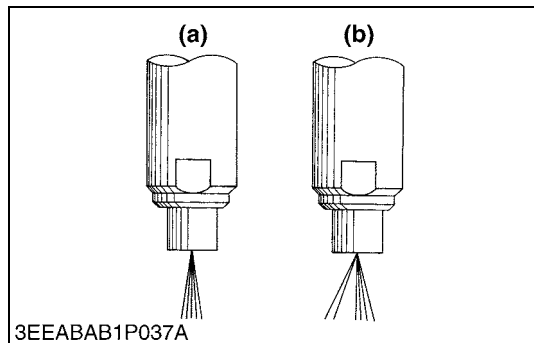

**Nozzle Spraying Condition**

1. Set the injection nozzle to a nozzle tester, and check the nozzle spraying condition.
2. If the spraying condition is damaged, replace the nozzle piece.

(a) Good

(b) Bad

9Y1210855ENS0019US0

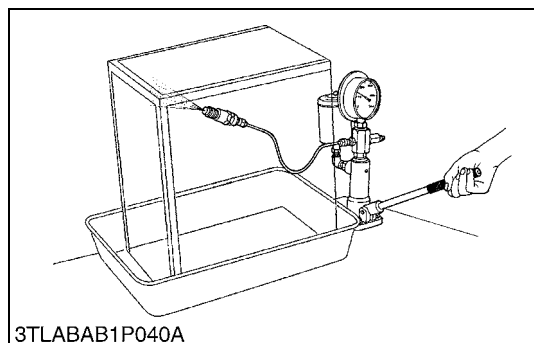

**Fuel Injection Pressure**

1. Set the injection nozzle to a nozzle tester.
2. Slowly move the tester handle to measure the pressure at which fuel begins jetting out from the nozzle.
3. If the measurement is not within the factory specifications, replace the adjusting washer (1) in the nozzle holder to adjust it.

**(Reference)**

- Pressure variation with 0.01 mm (0.0004 in.) difference of adjusting washer thickness.  
Approx. 235 kPa (2.4 kgf/cm<sup>2</sup>, 34 psi)

Fuel injection pressure	Factory specification	13.73 to 14.70 MPa 140.0 to 150.0 kgf/cm <sup>2</sup> 1992 to 2133 psi
-------------------------	-----------------------	--

(1) Adjusting Washer

9Y1210855ENS0020US0

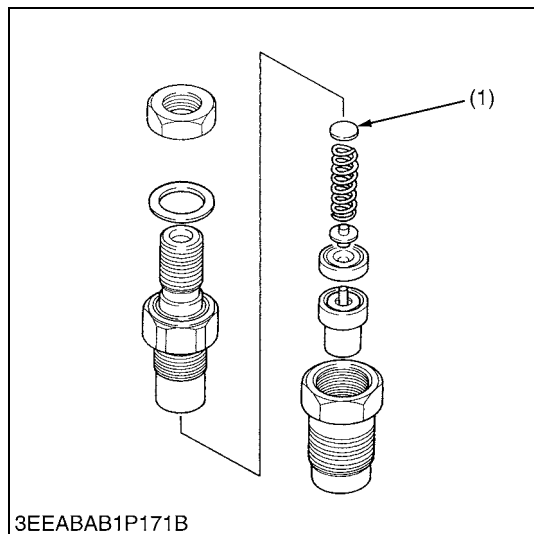

**Valve Seat Tightness**

1. Set the injection nozzle to a nozzle tester.
2. Raise the fuel pressure, and keep at 12.75 MPa (130.0 kgf/cm<sup>2</sup>, 1849 psi) for 10 seconds.
3. If any fuel leak is found, replace the nozzle piece.

Valve seat tightness	Factory specification	No fuel leak at 12.75 MPa 130.0 kgf/cm <sup>2</sup> 1849 psi
----------------------	-----------------------	---

9Y1210855ENS0021US0

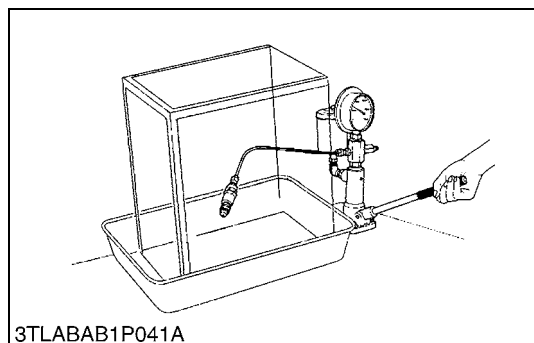

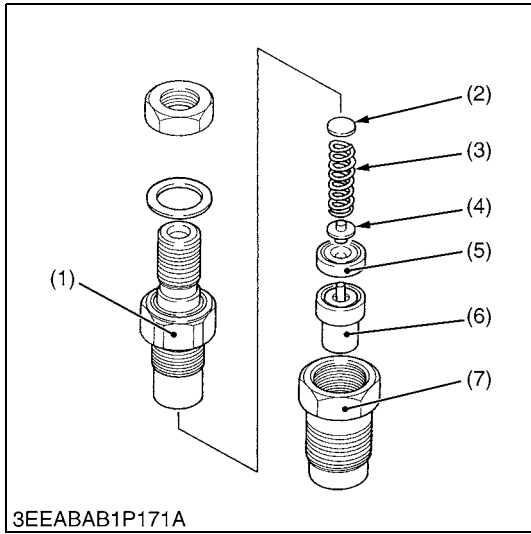

**Nozzle Holder**

1. Secure the nozzle retaining nut (7) with a vise.
2. Remove the nozzle holder (1), and remove parts inside.

**(When reassembling)**

- Assemble the nozzle in clean fuel oil.
- Install the push rod (4), noting its direction.
- After assembling the nozzle, be sure to adjust the fuel injection pressure.

Tightening torque	Nozzle holder	35 to 39 N·m 3.5 to 4.0 kgf·m 26 to 28 lbf·ft
	Overflow pipe retaining nut	20 to 24 N·m 2.0 to 2.5 kgf·m 15 to 18 lbf·ft
	Nozzle holder assembly	49 to 68 N·m 5.0 to 7.0 kgf·m 37 to 50 lbf·ft

- |                      |                          |
|----------------------|--------------------------|
| (1) Nozzle Holder    | (5) Distance Piece       |
| (2) Adjusting Washer | (6) Nozzle Piece         |
| (3) Nozzle Spring    | (7) Nozzle Retaining Nut |
| (4) Push Rod         |                          |

9Y1210855ENS0022US0

## [2] DISASSEMBLING AND ASSEMBLING

### (1) Separating Engine

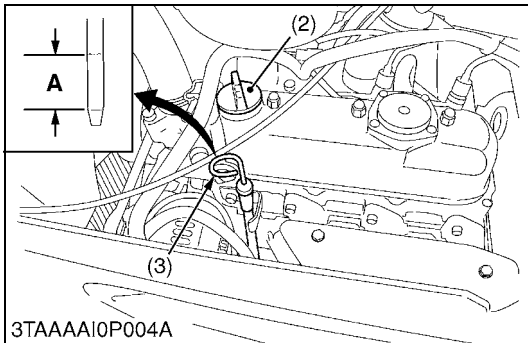
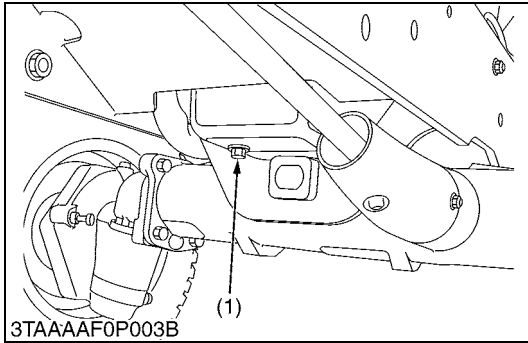

#### Draining Engine Oil

1. Start and warm up the engine for approx. 5 minutes.
2. Place an oil pan underneath the engine.
3. Remove the drain plug (1) to drain oil.
4. After draining, screw in the drain plug (1).

#### **(When refilling)**

- Fill the engine oil up to the upper line on the dipstick (3).

#### ■ **IMPORTANT**

- **Never mix two different type of oil.**
- **Use the proper SAE Engine Oil according to ambient temperature.**

**Refer to "4. LUBRICANTS, FUEL AND COOLANT" on page G-9.**

Engine oil	Capacity	BX1870D (D722-E4)	2.9 L 3.1 U.S.qts 2.6 Imp.qts
		BX2370D (D902-E4)	3.1 L 3.3 U.S.qts 2.7 Imp.qts
		BX2670D (D1005-E4)	3.5 L 3.7 U.S.qts 3.1 Imp.qts

Tightening torque	Drainer plug with copper gasket (M12, 1.25)	33 to 37 N·m 3.3 to 3.8 kgf·m 24 to 27 lbf·ft
-------------------	---	---

- (1) Drain Plug  
(2) Oil Inlet  
(3) Dipstick

**A: Oil level is acceptable within this range.**

9Y1210855ENS0023US0



#### Battery Cables and Battery

#### **⚠ CAUTION**

- **When disconnecting the battery cables, disconnect the negative cable from the battery first. When connecting, connect the positive cable to the battery first.**

1. Remove the under panel.
2. Disconnect the negative cable (2) from the battery (1).
3. Disconnect the positive cable (3) from the battery (1) and remove the battery (1).

- (1) Battery  
(2) Negative Cable

(3) Positive Cable

9Y1210855ENS0024US0



**Bonnet and Under Cover**

1. Open the bonnet (1), and then loosen the knob bolts (5) and pull forward to remove the under cover (2).
2. Disconnect the connectors (3) for head light and remove the bonnet bracket (4) with bonnet.

- |                 |                    |
|-----------------|--------------------|
| (1) Bonnet      | (4) Bonnet Bracket |
| (2) Under Cover | (5) Knob Bolt      |
| (3) Connector   |                    |

9Y1210855ENS0025US0

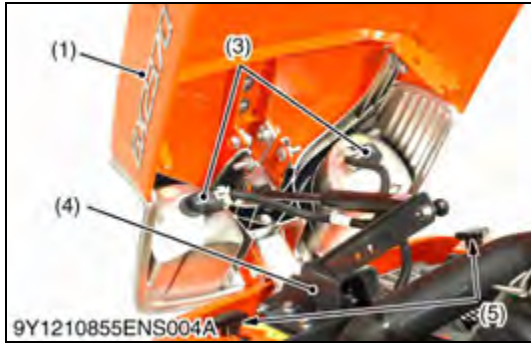

**Accelerator Wire, Bonnet Post, Fuel Hoses, Wiring Harness and Others**

1. Disconnect the wiring harness (4) from coolant temperature switch, stop solenoid, glow plug, starter motor, engine oil switch, alternator and ground cable.
2. Disconnect the accelerator wire (2) and fuel hoses (3).
3. Remove the bonnet post (1).

- |                      |                    |
|----------------------|--------------------|
| (1) Bonnet Post      | (3) Fuel Hose      |
| (2) Accelerator Wire | (4) Wiring Harness |

9Y1210855ENS0026US0





**Separating Engine from Front Axle**

1. Disconnect the ground cable.
2. Disconnect the front coupling (1).
3. Remove the engine mounting nuts (3).
4. Remove the engine support (4).
5. Hook the engine and separate the engine assembly with the radiator from the frame.

**(When reassembling)**

Tightening torque	Front coupling mounting bolt	24 to 27 N·m 2.4 to 2.8 kgf·m 18 to 20 lbf·ft
	Engine mounting nut	24 to 27 N·m 2.4 to 2.8 kgf·m 18 to 20 lbf·ft
	Cushion mounting nut	24 to 27 N·m 2.4 to 2.8 kgf·m 18 to 20 lbf·ft
	Engine support mounting screw	48 to 55 N·m 4.9 to 5.7 kgf·m 36 to 41 lbf·ft

- |                                  |                         |
|----------------------------------|-------------------------|
| (1) Front Coupling               | (3) Engine Mounting Nut |
| (2) Front Coupling Mounting Bolt | (4) Engine Support      |

9Y1210855ENS0027US0

## (2) Removing Outer Parts

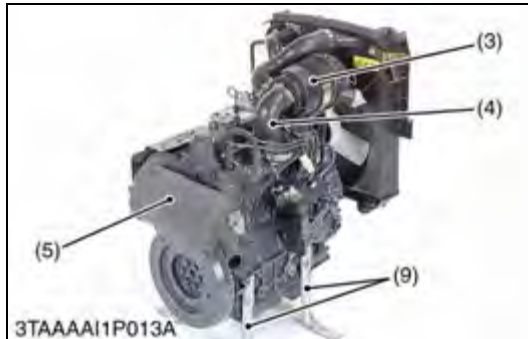
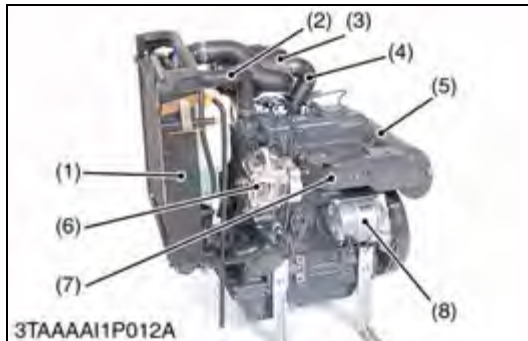

### Draining Coolant, Radiator, Air Cleaner and Muffler etc.

#### **⚠ CAUTION**

- **Never open the radiator cap while operating or immediately after stopping. Otherwise, hot water will spout out from the radiator. Wait for more than ten minutes to cool the radiator, before opening the cap.**
1. Set the engine stands (9) to the crankcase.
  2. Open the radiator drain plug, and remove radiator cap to completely drain the coolant.
  3. After all coolant is drained, close the drain plug.
  4. Loosen the inlet hose band and the radiator hose bands, and remove the radiator (1) with the radiator hoses (2) and the air cleaner (3).
  5. Loosen the fan belt. Remove the alternator (6), the starter motor (8), the fan and the fan belt.
  6. Remove the heat proof cover (7), the muffler (5) and the exhaust manifold.

Coolant with recovery tank	Capacity	BX1870D (D722-E4)	2.5 L 2.6 U.S.qts 2.2 Imp.qts
		BX2370D (D902-E4)	2.7 L 2.8 U.S.qts 2.4 Imp.qts
		BX2670D (D1005-E4)	3.3 L 3.5 U.S.qts 2.9 Imp.qts

- |                   |                      |
|-------------------|----------------------|
| (1) Radiator      | (6) Alternator       |
| (2) Radiator Hose | (7) Heat Proof Cover |
| (3) Air Cleaner   | (8) Starter Motor    |
| (4) Inlet Hose    | (9) Engine Stand     |
| (5) Muffler       |                      |

9Y1210855ENS0028US0

## (3) Cylinder Head and Valves

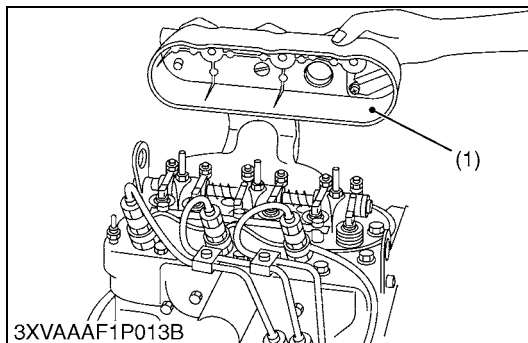

### Cylinder Head Cover

1. Disconnect the breather hose.
2. Remove the cylinder head cover nuts.
3. Remove the cylinder head cover (1).

#### **(When reassembling)**

- Check to see if the cylinder head cover gasket is not damaged.

#### **[BX1870D (D722-E4) and BX2370D (D902-E4)]**

Tightening torque	Cylinder head cover screw	9.81 to 11.2 N·m 1.00 to 1.15 kgf·m 7.24 to 8.31 lbf·ft
-------------------	---------------------------	---

#### **[BX2670D (D1005-E4)]**

Tightening torque	Cylinder head cover screw	7 to 8 N·m 0.7 to 0.9 kgf·m 5 to 6 lbf·ft
-------------------	---------------------------	---

- (1) Cylinder Head Cover

9Y1210855ENS0029US0

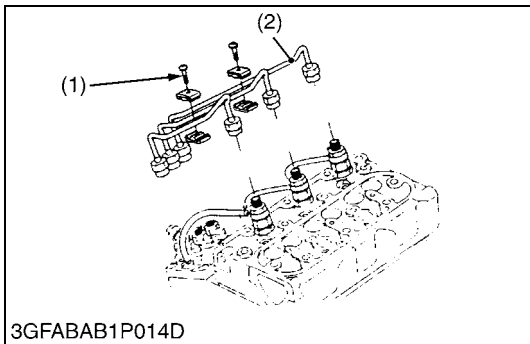

3GFABAB1P014D

**Injection Pipes**

1. Loosen the screws to the pipe clamp (1).
2. Remove the injection pipes (2).

**(When reassembling)**

- Send compressed air into the pipes to blow out dust. Then, reassemble the pipes in the reverse order.

Tightening torque	Injection pipe retaining nut	25 to 34 N·m 2.5 to 3.5 kgf·m 18 to 25 lbf·ft
-------------------	------------------------------	---

(1) Pipe Clamp

(2) Injection Pipe

9Y1210855ENS0030US0

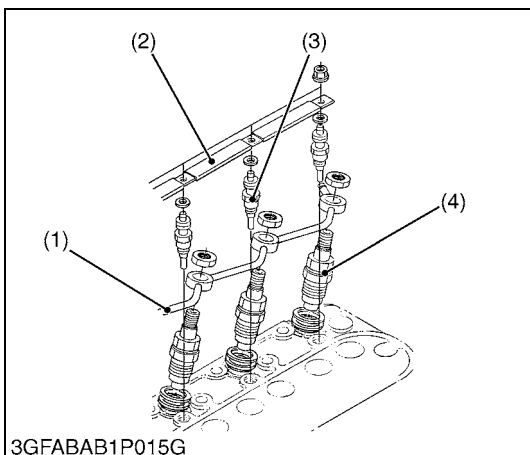

3GFABAB1P015G

**Nozzle Holder Assembly and Glow Plug**

1. Remove the overflow pipe (1).
2. Remove the nozzle holder assemblies (4).
3. Remove the copper gasket (5) and heat seal (6).
4. Remove the lead (2) from the glow plugs (3).
5. Remove the glow plugs (3).

**(When reassembling)**

- Replace the copper gasket and heat seal with new one.

Tightening torque	Overflow pipe retaining nut	20 to 24 N·m 2.0 to 2.5 kgf·m 15 to 18 lbf·ft
	Nozzle holder assembly	49 to 68 N·m 5.0 to 7.0 kgf·m 37 to 50 lbf·ft
	Glow plug	7.9 to 14 N·m 0.80 to 1.5 kgf·m 5.8 to 10 lbf·ft

(1) Overflow Pipe

(4) Nozzle Holder Assembly

(2) Lead

(5) Copper Gasket

(3) Glow Plug

(6) Heat Seal

9Y1210855ENS0031US0

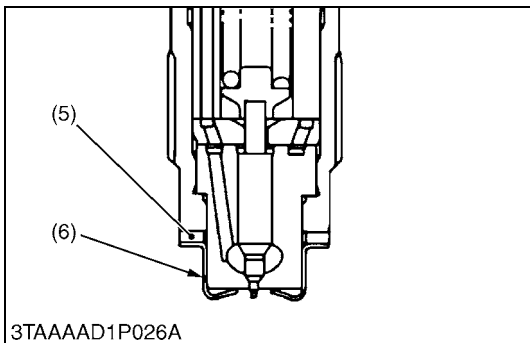

3TAAAD1P026A

**Nozzle Heat Seal Removal Procedure**

**■ IMPORTANT**

- Use a plus (phillips head) screw driver (1) that has a diameter which is bigger than the heat seal hole (Approx. 6 mm (1/4 in.)).

1. Drive screw driver (1) lightly into the heat seal hole.
2. Turn screw driver three or four times each way.
3. While turning the screw driver, slowly pull the heat seal (4) out together with the injection nozzle gasket (3).
4. If the heat seal drops, repeat the above procedure.

**(When reassembling)**

- Heat seal and injection nozzle gasket must be changed when the injection nozzle is removed for cleaning or for service.

(1) Plus Screw Driver

(3) Injection Nozzle Gasket

(2) Injection Nozzle

(4) Heat Seal

9Y1210855ENS0032US0

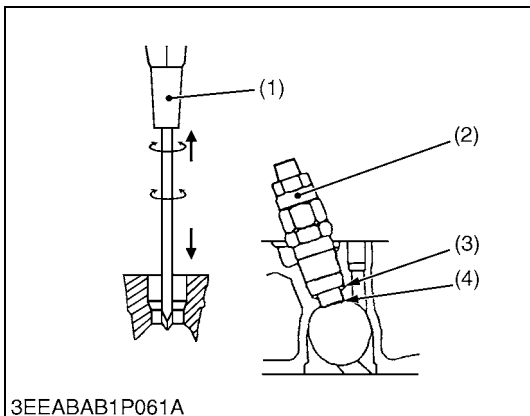

3EEABAB1P061A



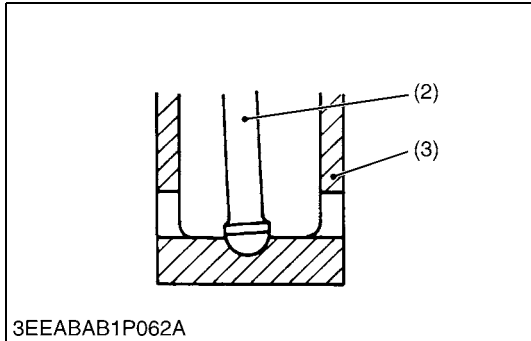
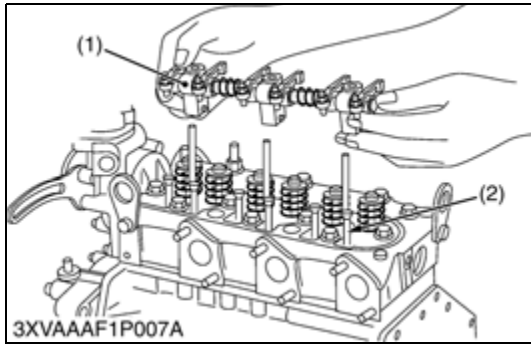

**Rocker Arm and Push Rod**

1. Remove the rocker arm bracket screw. [BX1870D (D722-E4) and BX2370D (D902-E4)]  
Remove the rocker arm bracket nut. [BX2670D (D1005-E4)]
2. Remove the rocker arm assembly (1).
3. Remove the push rods (2).

**(When reassembling)**

- When refitting the push rods (2) into the tappets (3), make sure the push rod locates correctly into the tappet seat.

**■ IMPORTANT**

- After installing the rocker arm, be sure to adjust the valve clearance.

**[BX1870D (D722-E4) and BX2370D (D902-E4)]**

Tightening torque	Rocker arm bracket screw	9.81 to 11.2 N·m 1.00 to 1.15 kgf·m 7.24 to 8.31 lbf·ft
-------------------	--------------------------	---

**[BX2670D (D1005-E4)]**

Tightening torque	Rocker arm bracket screw	22 to 26 N·m 2.2 to 2.7 kgf·m 16 to 19 lbf·ft
-------------------	--------------------------	---

- (1) Rocker Arm Assembly (3) Tappet  
(2) Push Rod

9Y1210855ENS0033US0

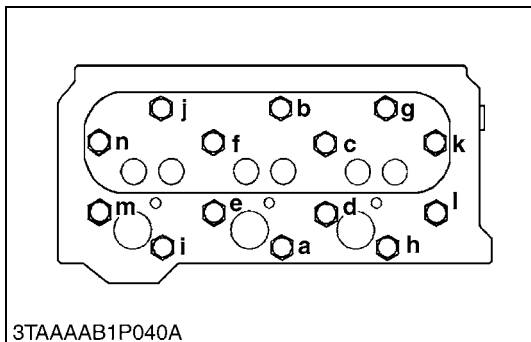
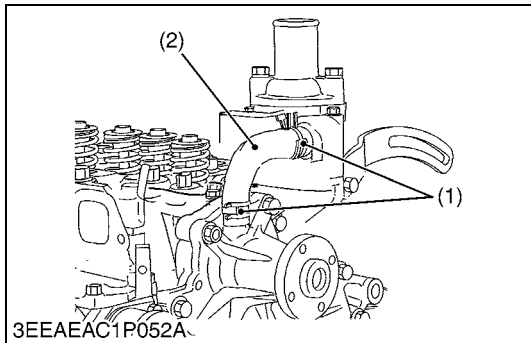

**Cylinder Head and Cylinder Head Gasket**

1. Loosen the pipe clamps (1), and remove the water return pipe (2).
2. Remove the cylinder head screw in the order of "n" to "a" and remove the cylinder head.
3. Remove the cylinder head gasket.

**(When reassembling)**

- Replace the cylinder head gasket with new one.
- When mounting the gasket, set it to the pin pipe holes. Be careful not to mount it reversely.
- The cylinder head should be free of scratches and dust.
- Install the cylinder head, using care not to damage the gasket.
- After applying engine oil to the thread of screws, tighten them in several steps and specified sequence "a" to "n".

**■ NOTE**

- Do not use O-ring on the pin pipe.
- It is not necessary to retighten the cylinder head screw and to readjust valve clearance after engine warmed up.

**[BX1870D (D722-E4) and BX2370D (D902-E4)]**

Tightening torque	Cylinder head screw	38 to 42 N·m 3.8 to 4.3 kgf·m 28 to 31 lbf·ft
-------------------	---------------------	---

**[BX2670D (D1005-E4)]**

Tightening torque	Cylinder head screw	64 to 68 N·m 6.5 to 7.0 kgf·m 47 to 50 lbf·ft
-------------------	---------------------	---

- (1) Clamp (2) Return Pipe (3) Pin Pipe
- n to a: To Loosen**  
**a to n: To Tighten**

9Y1210855ENS0034US0

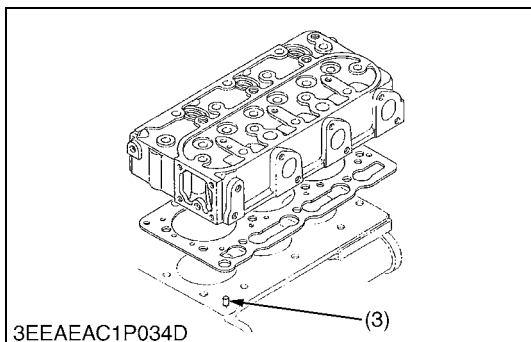



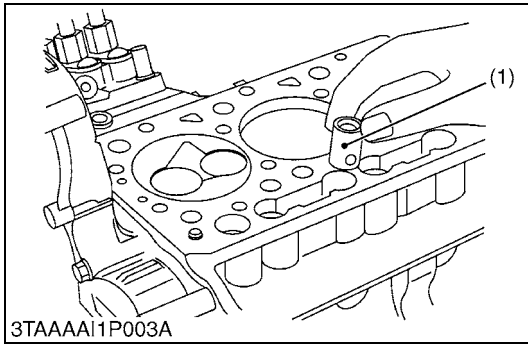

**Tappets**

1. Remove the tappets (1) from the crankcase.

**(When reassembling)**

- Visually check the contact between tappets and cams for proper rotation. If problem is found, replace tappets.
- Before installing the tappets, apply engine oil thinly around them.

■ **IMPORTANT**

- **Do not change the combination of tappet and tappet guide.**

- (1) Tappet

9Y1210855ENS0035US0

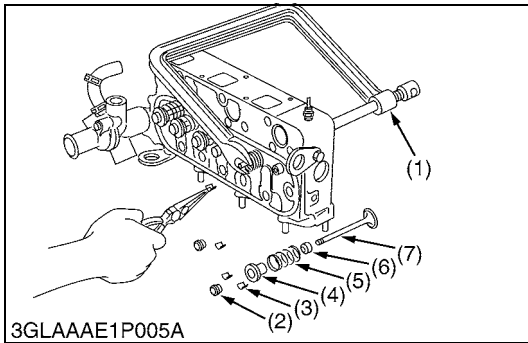

**Valves**

1. Remove the valve caps (2).
2. Remove the valve spring collet (3), pushing the valve spring retainer (4) by valve spring replacer (1).
3. Remove the valve spring retainer (4), valve spring (5) and valve stem seal (6).
4. Remove the valve (7).

**(When reassembling)**

- Wash the valve stem and valve guide hole, and apply engine oil sufficiently.
- After installing the valve spring collets, lightly tap the stem to assure proper fit with a plastic hammer.

■ **IMPORTANT**

- **Do not change the combination of valve and valve guide.**

- |                           |                     |
|---------------------------|---------------------|
| (1) Valve Spring Replacer | (5) Valve Spring    |
| (2) Valve Cap             | (6) Valve Stem Seal |
| (3) Valve Spring Collet   | (7) Valve           |
| (4) Valve Spring Retainer |                     |

9Y1210855ENS0036US0

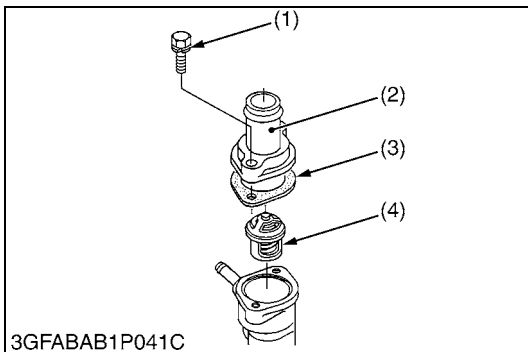

**Thermostat Assembly**

1. Remove the thermostat cover mounting screws (1), and remove the thermostat cover (2).
2. Remove the thermostat assembly (4).

**(When reassembling)**

- Apply a liquid gasket (Three Bond 1215 or equivalent) only at the thermostat cover side of the gasket (3).

- |                                     |                             |
|-------------------------------------|-----------------------------|
| (1) Thermostat Cover Mounting Screw | (3) Thermostat Cover Gasket |
| (2) Thermostat Cover                | (4) Thermostat Assembly     |

9Y1210855ENS0037US0

### (4) Gear Case and Timing Gears

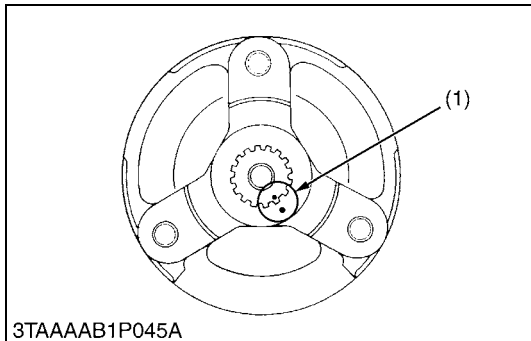
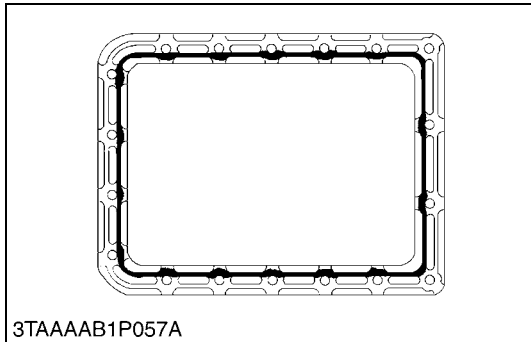
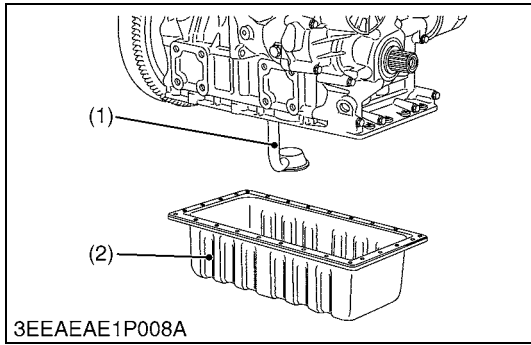

#### Oil Pan and Oil Strainer

1. Remove the oil pan mounting screws.
2. Remove the oil pan (2).
3. Remove the oil strainer (1).

#### (When reassembling)

- After cleaning the oil strainer, check to see that the filter mesh is clean, and install it.
- Visually check the O-ring, apply engine oil, and install it.
- Securely fit the O-ring to the oil strainer.
- To avoid uneven tightening, tighten oil pan mounting screws in diagonal order from the center.

#### ■ IMPORTANT

- **Scrape off the old adhesive completely. Wipe the sealing surface clean using waste cloth soaked with gasoline. Now apply new adhesive 3.0 to 5.0 mm (0.12 to 0.19 in.) thick all over the contact surface. Apply the adhesive also on the center of the flange as well as on the inner wall of each screw hole.**
- **Cut the nozzle of the "liquid gasket" container at its second notch. Apply "liquid gasket" about 5.0 mm (0.19 in.) thick. Within 20 minutes after the application of fluid sealant, reassemble the components. Wait then for about 30 minutes, and pour oil in the crankcase.**

(1) Oil Strainer

(2) Oil Pan

9Y1210855ENS0038US0

#### Fan Drive Pulley

1. Secure the flywheel to keep it from turning.
2. Remove the fan drive pulley screw.
3. Draw out the fan drive pulley with a puller.

#### (When reassembling)

- Install the pulley to crankshaft, aligning the mark (1) on them (3-cylinder engine).
- Apply engine oil to the fan drive pulley retaining screw. And tighten it.

#### [BX1870D (D722-E4) and BX2370D (D902-E4)]

Tightening torque	Fan drive pulley screw	118 to 127 N·m 12.0 to 13.0 kgf·m 86.8 to 94.0 lbf·ft
-------------------	------------------------	---

#### [BX2670D (D1005-E4)]

Tightening torque	Fan drive pulley screw	236 to 245 N·m 24.0 to 25.0 kgf·m 174 to 180 lbf·ft
-------------------	------------------------	---

(1) Aligning Mark

9Y1210855ENS0039US0

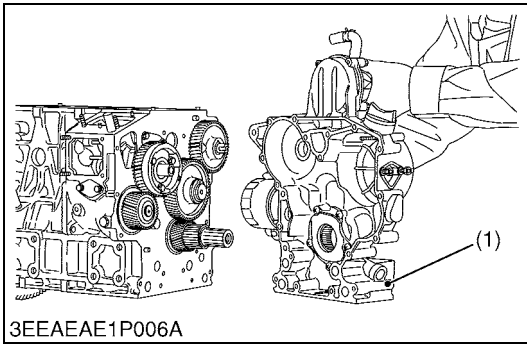

**Gear Case**

1. Remove the fuel feed pump.
2. Remove the gear case.

**(When reassembling)**

- Grease thinly to the oil seal, and install it, ensuring the lip does not come off.

(1) Gear Case

- a: Bolt Length = 45 mm (1.8 in.)
- b: Bolt Length = 50 mm (2.0 in.)
- c: Bolt Length = 55 mm (2.2 in.)
- d: Bolt Length = 65 mm (2.6 in.)
- e: Bolt Length = 68 mm (2.7 in.)
- f: Bolt Length = 70 mm (2.8 in.)
- g: Bolt Length = 85 mm (3.3 in.)
- h: Nut

9Y1210855ENS0040US0

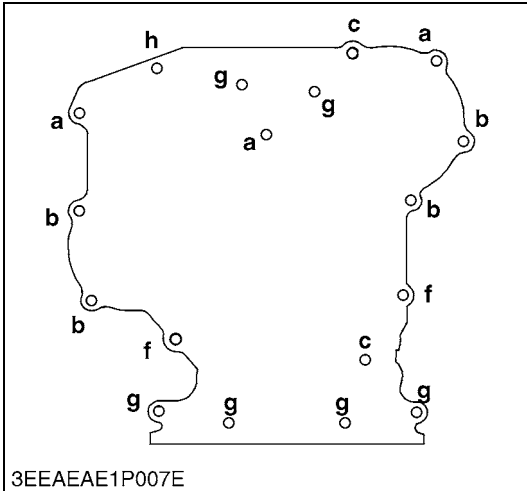

**Speed Control Plate**

1. Remove the engine stop solenoid.
2. Remove the speed control plate (1).

**(When reassembling)**

- Apply a liquid gasket (Three Bond 1215 or equivalent) to both sides of the solenoid cover gasket and control plate gasket.
- Be careful not to drop the governor spring (2) into the crankcase.

(1) Speed Control Plate

(2) Governor Spring

9Y1210855ENS0041US0

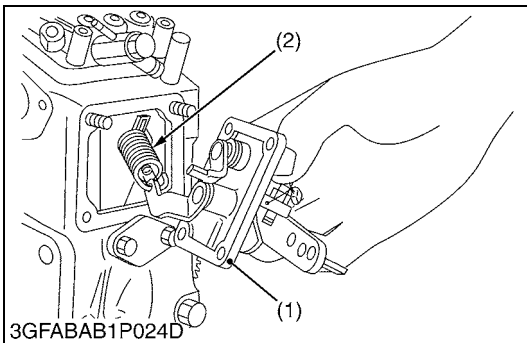

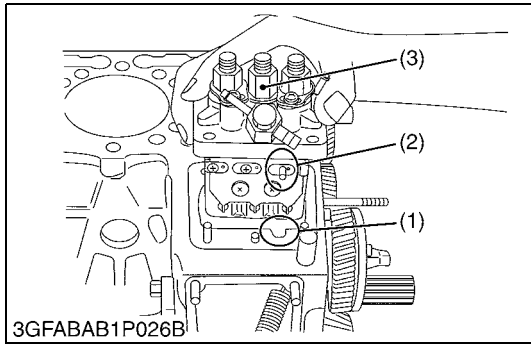

**Injection Pump**

1. Disconnect the start spring (4) on the thrust lever side (5).
2. Align the control rack pin (2) with the notch (1) on the crankcase, and remove the injection pump (3).
3. Remove the injection pump shims.
4. In principle, the injection pump should not be disassembled.

**(When reassembling)**

- When installing the injection pump, insert the control rack pin (2) firmly into the groove (7) of the thrust lever of fork lever.

**NOTE**

- Addition or reduction of shim (0.05 mm, 0.002 in.) delays or advances the injection timing by approx. 0.0087 rad (0.50 °).
- In disassembling and replacing, be sure to use the same number or new gasket shims with the same thickness.

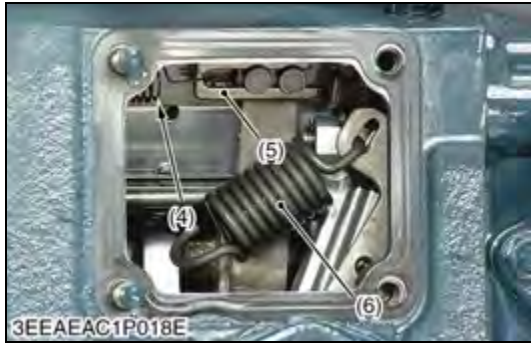

- |                      |                     |
|----------------------|---------------------|
| (1) Notch            | (5) Thrust Lever    |
| (2) Control Rack Pin | (6) Governor Spring |
| (3) Injection Pump   | (7) Groove          |
| (4) Start Spring     |                     |

9Y1210855ENS0042US0



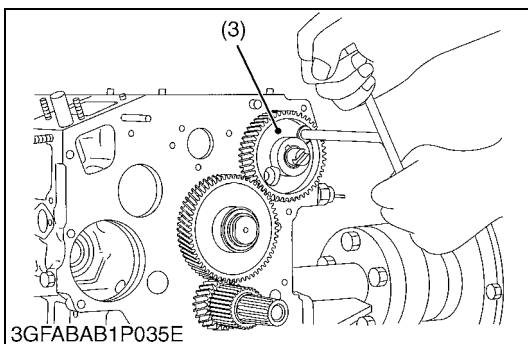
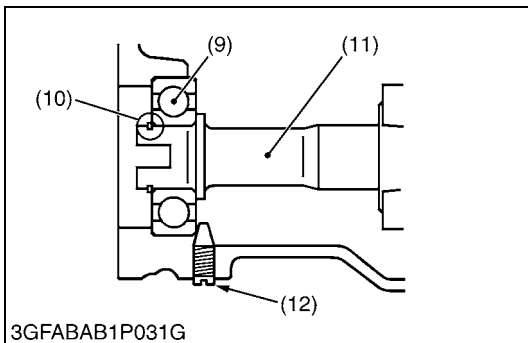
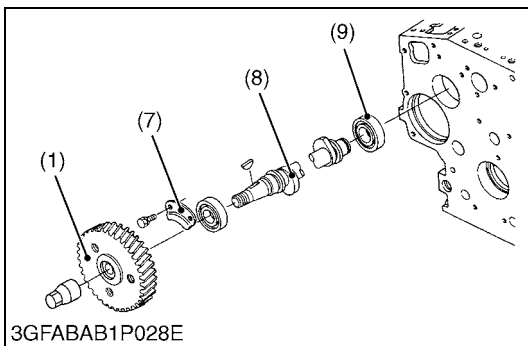
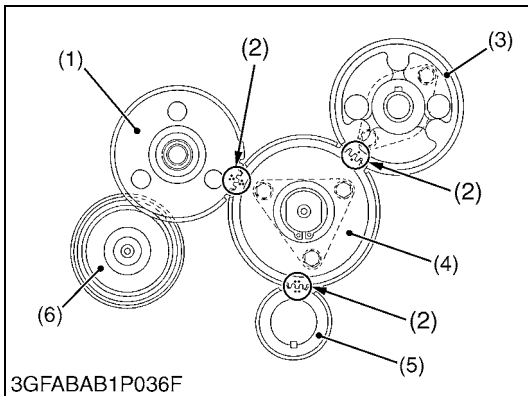

### Cam Gear, Idle Gear 1, 2 and Governor Gear

1. Remove the idle gear 1 (4).
2. Remove the fuel camshaft stopper (7).
3. Draw out the fuel cam gear (1) with fuel camshaft (8).
4. Remove the camshaft stopper bolt.
5. Remove the cam gear (3) with camshaft.
6. Remove the external snap ring (10) from the governor shaft (11).
7. Remove the governor gear (6) with governor shaft (11).

#### NOTE

- **Three-lever type fork lever**

To remove the governor shaft, follow the procedures in 5, 6 above and never remove fork lever and the max torque limiter.

#### (When reassembling)

- Apply engine oil thinly to the fuel camshaft before installation.
- Make sure to assemble the external snap ring of the governor shaft.
- Check the governor shaft for smooth rotation.

#### IMPORTANT

- **When replacing the ball bearing of governor shaft, securely fit the ball bearing (9) to the crankcase, apply an adhesive (Three Bond 1324B or equivalent) to the set screw (12), and fasten the screw until its tapered part contacts the circumferential end of the ball bearing.**
- **When installing the idle gear, be sure to align the alignment marks (2) on each gears.**

- |                    |                           |
|--------------------|---------------------------|
| (1) Fuel Cam Gear  | (7) Fuel Camshaft Stopper |
| (2) Alignment Mark | (8) Fuel Camshaft         |
| (3) Cam Gear       | (9) Ball Bearing          |
| (4) Idle Gear 1    | (10) External Snap Ring   |
| (5) Crank Gear     | (11) Governor Shaft       |
| (6) Governor Gear  | (12) Set Screw            |

9Y1210855ENS0043US0

## (5) Piston and Connecting Rod

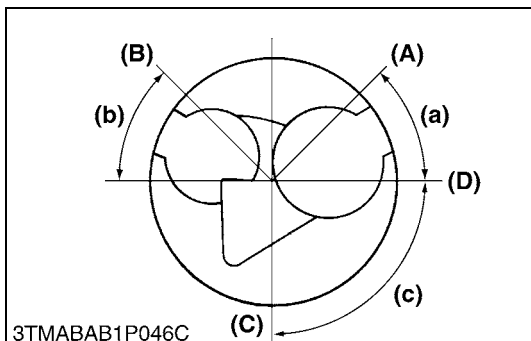
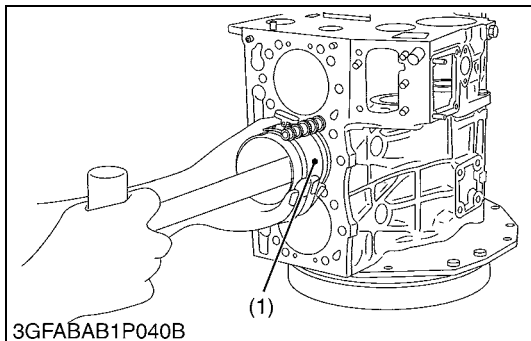
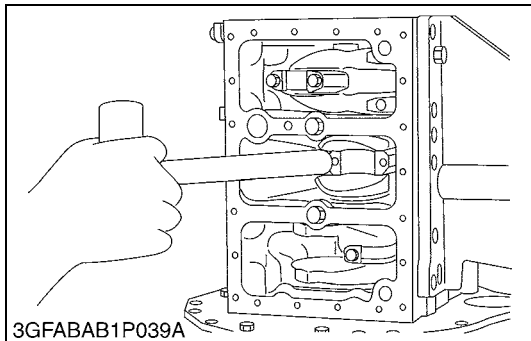
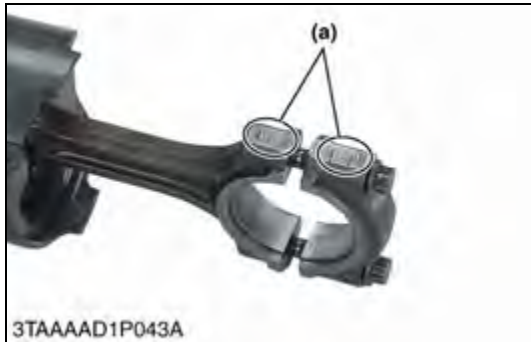
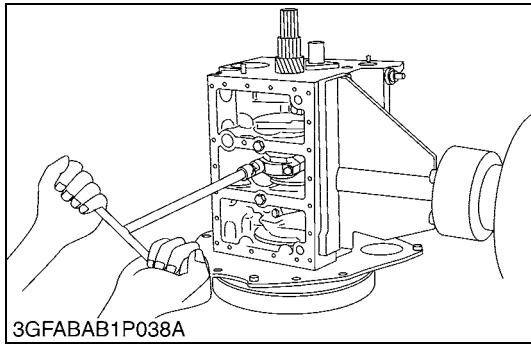

### Connecting Rod

1. Remove the connecting rod cap.

#### (When reassembling)

- Align the marks (a) with each other. (Face the marks toward the injection pump.)
- Apply engine oil to the connecting rod screws and lightly screw it in by hand, then tighten it to the specified torque.

If the connecting rod screw won't be screwed in smoothly, clean the threads.

If the connecting rod screw is still hard to screw in, replace it.

#### [BX1870D (D722-E4) and BX2370D (D902-E4)]

Tightening torque	Connecting rod screw	27 to 30 N·m 2.7 to 3.1 kgf·m 20 to 22 lbf·ft
-------------------	----------------------	---

#### [BX2670D (D1005-E4)]

Tightening torque	Connecting rod screw	42 to 46 N·m 4.2 to 4.7 kgf·m 31 to 33 lbf·ft
-------------------	----------------------	---

(a) Mark

9Y1210855ENS0044US0

### Pistons

1. Turn the flywheel and bring the piston to top dead center.
2. Draw out the piston upward by lightly tapping it from the bottom of the crankcase with the grip of a hammer.
3. Draw out the other piston in the same method as above.

#### (When reassembling)

- Before inserting the piston into the cylinder, apply enough engine oil to the piston.
- When inserting the piston into the cylinder, face the mark on the connecting rod to the injection pump.

#### ■ IMPORTANT

- Do not change the combination of cylinder and piston. Make sure of the position of each piston by marking. For example, mark "1" on the No.1 piston.
- When installing the piston into the cylinder, place the gaps of all the piston rings as shown in the figure.
- Carefully insert the pistons using a piston ring compressor (1). Otherwise, their chrome-plated section may be scratched, causing trouble inside the cylinder.

(1) Piston Ring Compressor

- (A) Top Ring Gap
- (B) Second Ring Gap
- (C) Oil Ring Gap
- (D) Piston Pin Hole
- (a) 0.79 rad (45 °)
- (b) 0.79 rad (45 °)
- (c) 1.6 rad (90 °)

9Y1210855ENS0045US0

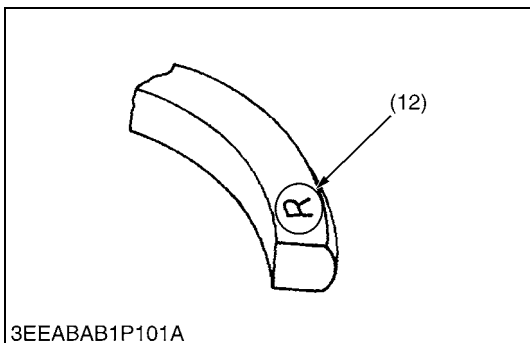
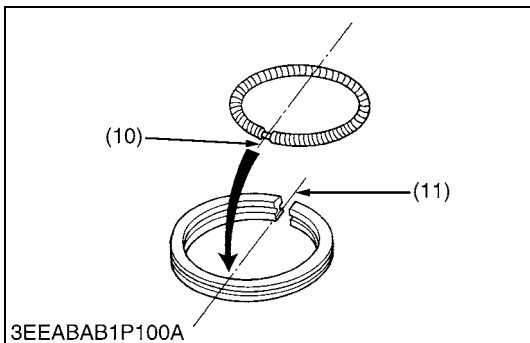
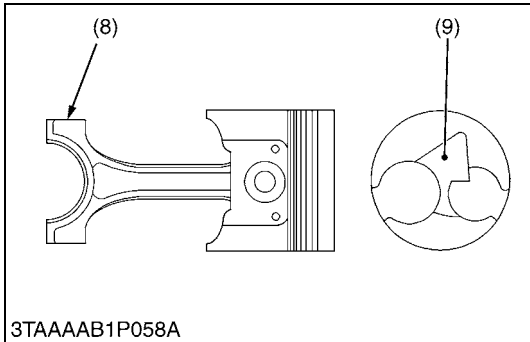
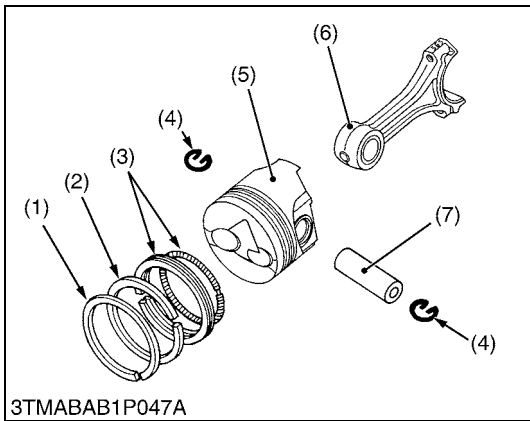

**Piston Ring and Connecting Rod**

1. Remove the piston rings using a piston ring tool.
2. Remove the piston pin (7), and separate the connecting rod (6) from the piston (5).

**(When reassembling)**

- Install the rings so that the manufacturer's mark (12) near the gap faces the top of the piston.
- When installing the oil ring onto the piston, place the expander joint (10) on the opposite side of the oil ring gap (11).
- Apply engine oil to the piston pin.
- When installing the connecting rod to the piston, immerse the piston in 80 °C (176 °F) oil for 10 to 15 minutes and insert the piston pin to the piston.
- When installing the connecting rod to the piston, align the mark (8) on the connecting rod to the fan-shaped concave (9).

■ **NOTE**

- **Mark the same number on the connecting rod and the piston so as not to change the combination.**

- |                          |                          |
|--------------------------|--------------------------|
| (1) Top Ring             | (7) Piston Pin           |
| (2) Second Ring          | (8) Mark                 |
| (3) Oil Ring             | (9) Fan-shaped Concave   |
| (4) Piston Pin Snap Ring | (10) Expander Joint      |
| (5) Piston               | (11) Oil Ring Gap        |
| (6) Connecting Rod       | (12) Manufacturer's Mark |

9Y1210855ENS0046US0

## (6) Flywheel and Crankshaft

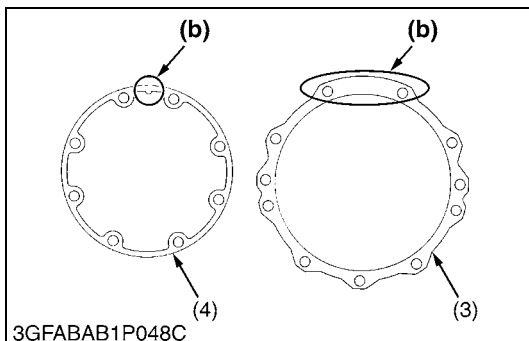
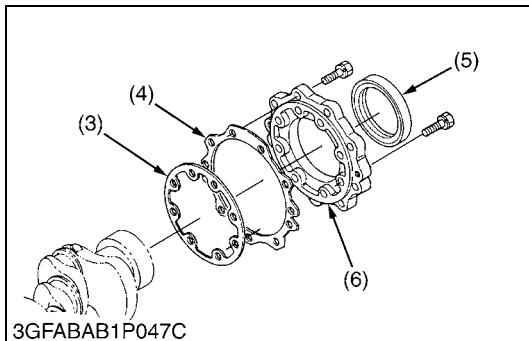
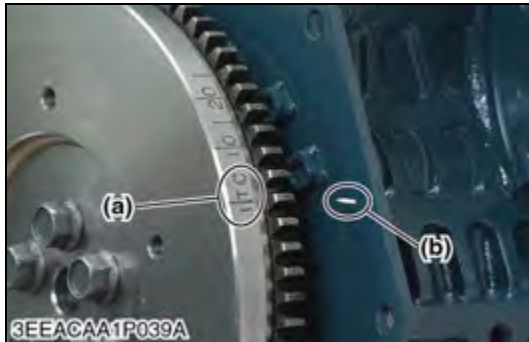
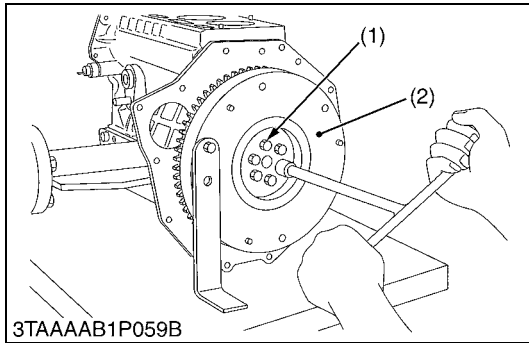

### Flywheel

1. Secure the flywheel to keep it from turning, using a flywheel stopper.
2. Remove all flywheel screws (1) and then remove the flywheel (2).

#### (When reassembling)

- Align the "1TC" mark (a) on the outer surface of the flywheel horizontally with the alignment mark (b) on the rear end plate. Now fit the flywheel in position.
- Apply engine oil to the threads and the undercut surface of the flywheel screw and fit the screw.

Tightening torque	Flywheel screw	54 to 58 N·m 5.5 to 6.0 kgf·m 40 to 43 lbf·ft
-------------------	----------------	---

- (1) Flywheel Screw  
(2) Flywheel

- (a) 1TC Mark  
(b) Alignment Mark

9Y1210855ENS0047US0

### Bearing Case Cover

1. Remove the bearing case cover mounting screws.
2. Remove the bearing case cover (6).

#### (When reassembling)

- Fit the bearing case gasket (3) and the bearing case cover gasket (4) with correct directions.
- Install the bearing case cover (6) to position the casting mark "UP" on it upward.
- Apply engine oil to the oil seal (5) lip and be careful that it is not rolled when installing.
- Tighten the bearing case cover mounting screws with even force on the diagonal line.

Tightening torque	Bearing case cover mounting screw	9.81 to 11.2 N·m 1.00 to 1.15 kgf·m 7.24 to 8.31 lbf·ft
-------------------	-----------------------------------	---

- (1) Bearing Case Cover Mounting Screw (Inside)  
(2) Bearing Case Cover Mounting Screw (Outside)  
(3) Bearing Case Gasket  
(4) Bearing Case Cover Gasket

- (5) Oil Seal  
(6) Bearing Case Cover  
(a) Top Mark "UP"  
(b) Upside

9Y1210855ENS0048US0



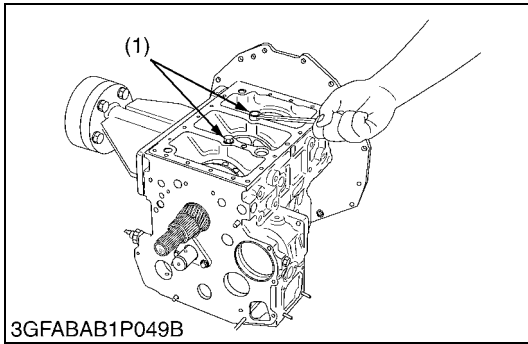

**Crankshaft Assembly**

1. Remove the main bearing case screw 2 (1).
2. Pull out the crankshaft assembly.

■ **IMPORTANT**

- **Be careful to protect crankshaft bearing 1 from scratches, caused by the crank gear, etc.. (Wrap the gear in vinyl tape, etc..)**

**(When reassembling)**

- Clean the oil passage of the crankshaft with compressed air.
- Apply oil to the main bearing case screw 2 (1).
- Install the crankshaft assembly, aligning the screw hole of main bearing case with the screw hole of crankcase.
- Clean the oil passage of the crankshaft with compressed air.

**[BX1870D (D722-E4) and BX2370D (D902-E4)]**

Tightening torque	Main bearing case screw 2	27 to 30 N·m 2.7 to 3.1 kgf·m 20 to 22 lbf·ft
-------------------	---------------------------	---

**[BX2670D (D1005-E4)]**

Tightening torque	Main bearing case screw 2	49 to 53 N·m 5.0 to 5.5 kgf·m 37 to 39 lbf·ft
-------------------	---------------------------	---

(1) Main Bearing Case Screw 2

9Y1210855ENS0049US0

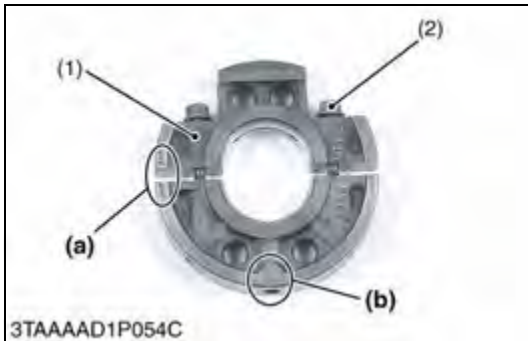

**Main Bearing Case Assembly**

1. Remove the two main bearing case screws 1 (2) of each main bearing cases.
2. Remove the main bearing case from crankshaft.

**(When reassembling)**

- Clean the oil passage in the main bearing cases.
- Apply clean engine oil on the bearings.
- Install the main bearing case assemblies in the original positions.

Since diameters of main bearing cases vary, install them in order of makings (b) (A, B, C) from the gear case side.

- Match the alignment numbers (a) on the main bearing case assembly 1.
- When installing the main bearing case 1 and 2, face the mark "FLYWHEEL" to the flywheel.
- Install the thrust bearing (3) with its oil groove facing outward.
- Make sure that the main bearing case moves smoothly after tightening the main bearing case screw 1 to the specified torque.

**[BX1870D (D722-E4) and BX2370D (D902-E4)]**

Tightening torque	Main bearing case screw 1	13 to 15 N·m 1.3 to 1.6 kgf·m 9.4 to 11 lbf·ft
-------------------	---------------------------	--

**[BX2670D (D1005-E4)]**

Tightening torque	Main bearing case screw 1	30 to 34 N·m 3.0 to 3.5 kgf·m 22 to 25 lbf·ft
-------------------	---------------------------	---

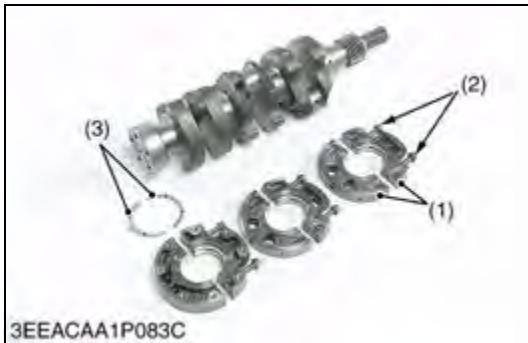

- (1) Main Bearing Case Assembly 1      (a) Alignment Number
- (2) Main Bearing Case Screw 1      (b) Marking (A, B, C)
- (3) Thrust Bearing

9Y1210855ENS0050US0

### [3] SERVICING

#### (1) Cylinder Head and Valves

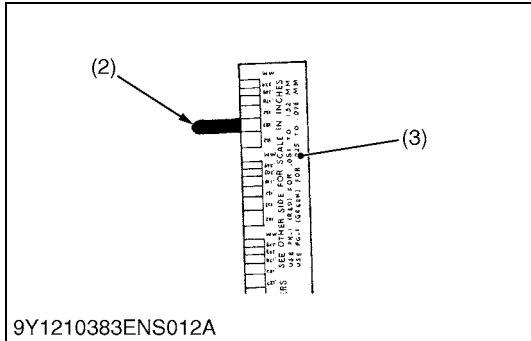
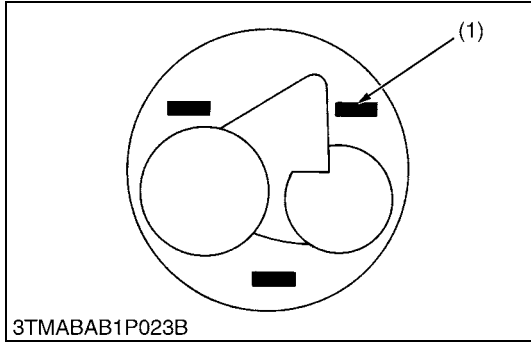

#### Top Clearance

1. Remove the cylinder head.
2. With the piston at TDC, use grease to affix three or four plastigauges (1) of a diameter 1.5 mm (0.059 in.) × 5.0 to 7.0 mm (0.20 to 0.27 in.) long to the crown of the piston; keep the gauges away from the intake valve and combustion chamber fittings.
3. Take the piston to an intermediate position, install the cylinder head and tighten the head bolts to the specified torque.
4. Turn the crankshaft so the piston goes through TDC.
5. Remove the cylinder head and compare the width of the crushed plastigauges (2) with the scale.
6. If they are out of spec, check the oil clearance of the crank pin, journals and piston pins.

#### NOTE

- Top clearance = Width of the crushed plastigauge (2).

#### [BX1870D (D722-E4) and BX2370D (D902-E4)]

Top clearance	Factory specification	0.55 to 0.70 mm 0.022 to 0.027 in.
---------------	-----------------------	---------------------------------------

Tightening torque	Cylinder head screw	38 to 42 N·m 3.8 to 4.3 kgf·m 28 to 31 lbf·ft
-------------------	---------------------	---

#### [BX2670D (D1005-E4)]

Top clearance	Factory specification	0.55 to 0.75 mm 0.022 to 0.029 in.
---------------	-----------------------	---------------------------------------

Tightening torque	Cylinder head screw	64 to 68 N·m 6.5 to 7.0 kgf·m 47 to 50 lbf·ft
-------------------	---------------------	---

- (1) Plastigauge (3) Scale  
(2) Crushed Plastigauge

9Y1210855ENS0051US0

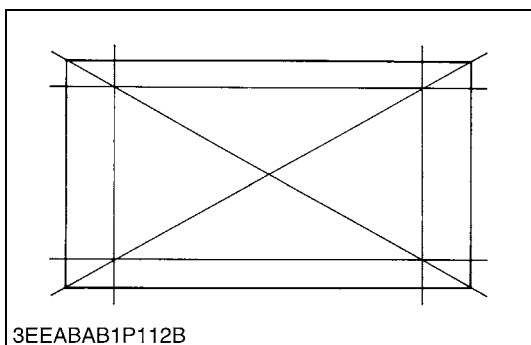
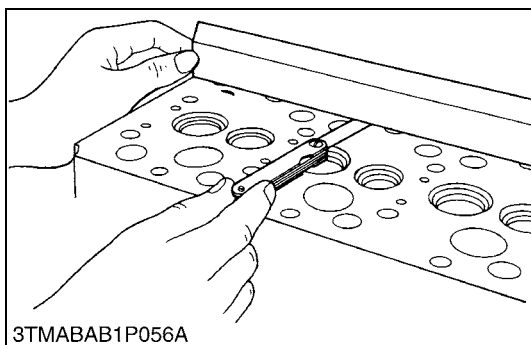

#### Cylinder Head Surface Flatness

1. Clean the cylinder head surface.
2. Place a straightedge on the cylinder head's four sides and two diagonal as shown in the figure.
3. Measure the clearance with a thickness gauge.
4. If the measurement exceeds the allowable limit, correct it with a surface grinder.

#### IMPORTANT

- Do not place the straightedge on the combustion chamber.
- Be sure to check the valve recessing after correcting.

Cylinder head surface flatness	Allowable limit	0.05 mm 0.002 in.
--------------------------------	-----------------	----------------------

9Y1210855ENS0052US0

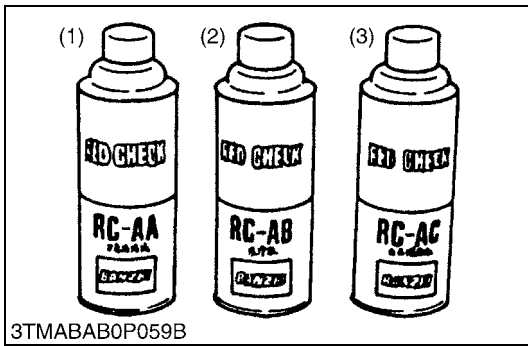

**Cylinder Head Flaw**

1. Prepare an air spray red check.
2. Clean the surface of the cylinder head with detergent (2).
3. Spray the cylinder head surface with the red permeative liquid (1). Leave it five to ten minutes after spraying.
4. Wash away the red permeative liquid on the cylinder head surface with the detergent (2).
5. Spray the cylinder head surface with white developer (3).
6. If flawed, it can be identified as red marks.

- (1) Red Permeative Liquid (3) White Developer  
 (2) Detergent

9Y1210855ENS0053US0

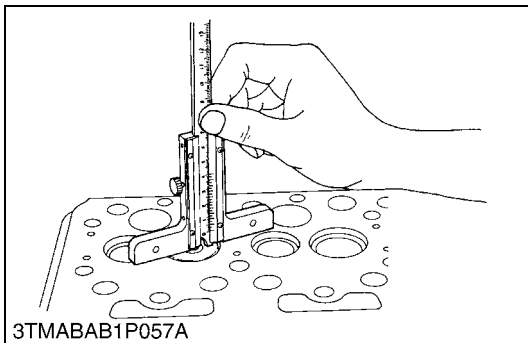

**Valve Recessing**

1. Clean the cylinder head surface, valve face and valve seat.
2. Insert the valve into the valve guide.
3. Measure the valve recessing with a depth gauge.
4. If the measurement exceeds the allowable limit, replace the valve.
5. If it still exceeds the allowable limit after replacing the valve, replace the cylinder head.

**[BX1870D (D722-E4) and BX2370D (D902-E4)]**

Valve recessing	Factory specification	0.10 (protrusion) to 0.10 (recessing) mm 0.0039 (protrusion) to 0.0039 (recessing) in.
	Allowable limit	0.30 (recessing) mm 0.012 (recessing) in.

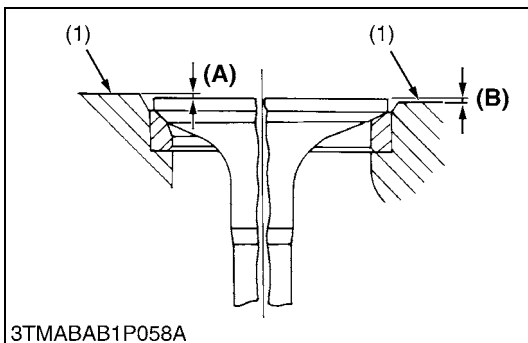

**[BX2670D (D1005-E4)]**

Valve recessing	Factory specification	0.050 (protrusion) to 0.25 (recessing) mm 0.0020 (protrusion) to 0.0098 (recessing) in.
	Allowable limit	0.40 (recessing) mm 0.016 (recessing) in.

- (1) Cylinder Head Surface (A) Recessing (B) Protrusion

9Y1210855ENS0054US0

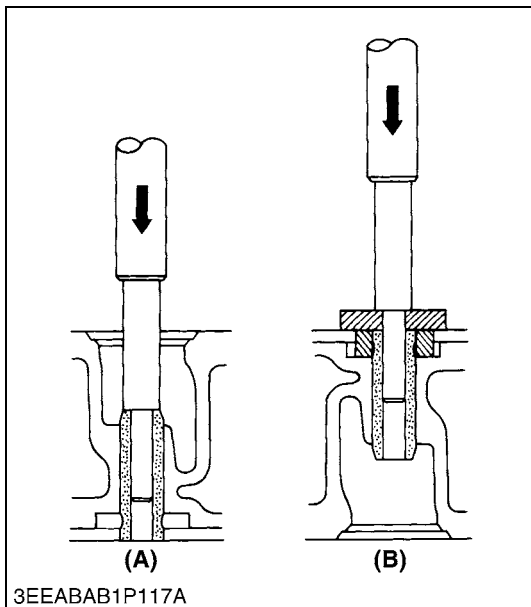
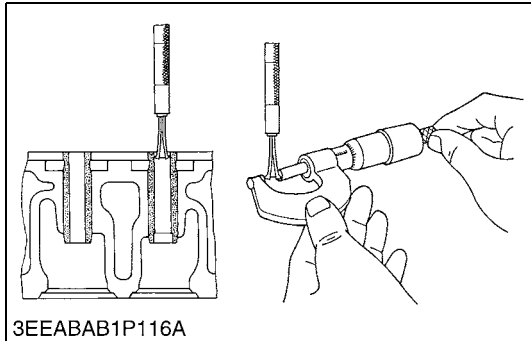
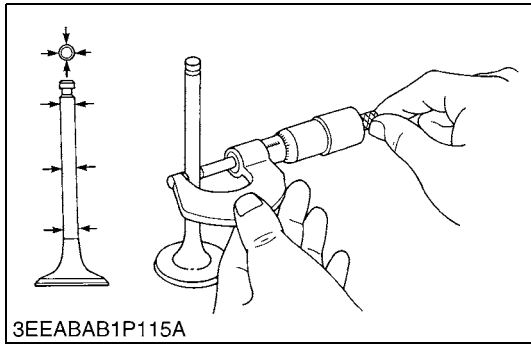

**Clearance between Valve Stem and Valve Guide**

1. Remove carbon from the valve guide section.
2. Measure the valve stem O.D. with an outside micrometer.
3. Measure the valve guide I.D. with a small hole gauge, and calculate the clearance.
4. If the clearance exceeds the allowable limit, replace the valves. If it still exceeds the allowable limit, replace the valve guide.

**[BX1870D (D722-E4) and BX2370D (D902-E4)]**

Clearance between valve stem and valve guide	Factory specification	0.030 to 0.057 mm 0.0012 to 0.0022 in.
	Allowable limit	0.10 mm 0.0039 in.

Valve stem O.D.	Factory specification	5.968 to 5.980 mm 0.2350 to 0.2354 in.
Valve guide I.D.	Factory specification	6.010 to 6.025 mm 0.2367 to 0.2372 in.

**[BX2670D (D1005-E4)]**

Clearance between valve stem and valve guide	Factory specification	0.035 to 0.065 mm 0.0014 to 0.0025 in.
	Allowable limit	0.10 mm 0.0039 in.

Valve stem O.D.	Factory specification	6.960 to 6.975 mm 0.2741 to 0.2746 in.
Valve guide I.D.	Factory specification	7.010 to 7.025 mm 0.2760 to 0.2765 in.

9Y1210855ENS0055US0

**Replacing Valve Guide**

**(When removing)**

1. Press out the used valve guide using a valve guide replacing tool. (See page "SPECIAL TOOLS".)

**(When installing)**

1. Clean a new valve guide and valve guide bore, and apply engine oil to them.
2. Press in a new valve guide using a valve guide replacing tool.
3. Ream precisely the I.D. of the valve guide to the specified dimension.

**[BX1870D (D722-E4) and BX2370D (D902-E4)]**

Valve guide I.D. (Intake and exhaust)	Factory specification	6.010 to 6.025 mm 0.2367 to 0.2372 in.
---------------------------------------	-----------------------	---

**[BX2670D (D1005-E4)]**

Valve guide I.D. (Intake and exhaust)	Factory specification	7.010 to 7.025 mm 0.2760 to 0.2765 in.
---------------------------------------	-----------------------	---

**■ IMPORTANT**

- Do not hit the valve guide with a hammer during replacement.

(A) When Removing

(B) When Installing

9Y1210855ENS0056US0

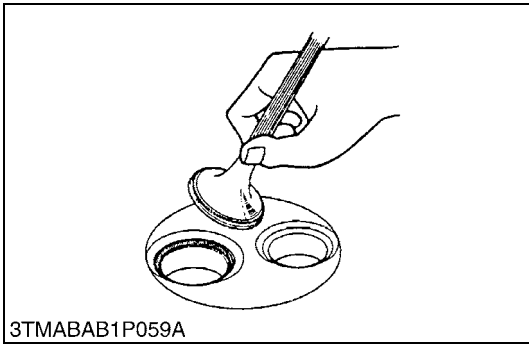

**Valve Seating**

1. Coat the valve face lightly with prussian blue and put the valve on its seat to check the contact.
2. If the valve does not seat all the way around the valve seat or the valve contact is less than 70 %, correct the valve seating as follows.
3. If the valve contact does not comply with the reference value, replace the valve or correct the contact of valve seating.

Valve seat width	Factory specification	2.12 mm 0.835 in.
------------------	-----------------------	----------------------

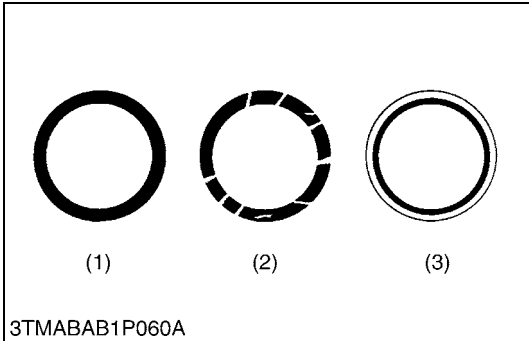

- (1) Correct (3) Incorrect  
 (2) Incorrect

9Y1210855ENS0057US0

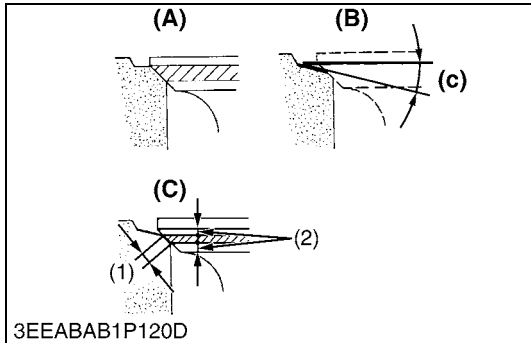
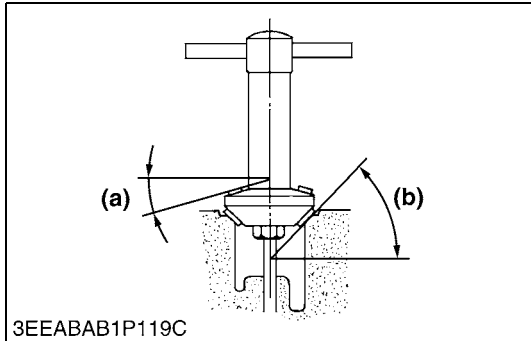
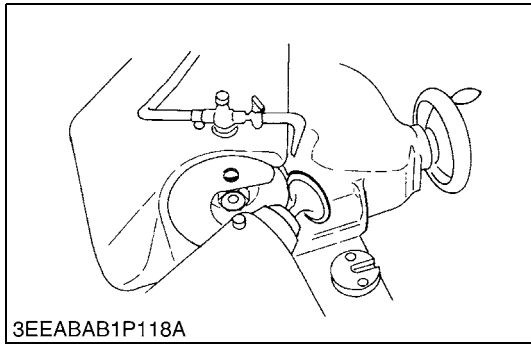

**Correcting Valve and Valve Seat**

■ **NOTE**

- Before correcting the valve and seat, check the valve stem and the I.D. of valve guide section, and repair them if necessary.
- After correcting the valve seat, be sure to check the valve recessing.

**1) Correcting Valve**

1. Correct the valve with a valve refacer.

**[BX1870D (D722-E4) and BX2370D (D902-E4)]**

Valve face angle	Factory specification	0.79 rad 45 °
------------------	-----------------------	------------------

**[BX2670D (D1005-E4)]**

Valve face angle	Factory specification	IN.	1.0 rad 60 °
		EX.	0.79 rad 45 °

**2) Correcting Valve Seat**

1. Slightly correct the seat surface with a 1.0 rad (60 °) (intake valve) or 0.79 rad (45 °) (exhaust valve) valve seat cutter.
2. Resurface the seat surface with a 0.52 rad (30 °) valve seat cutter to intake valve seat and with a 0.26 rad (15 °) valve seat cutter to exhaust valve seat so that the width is close to specified valve seat width (2.12 mm, 0.0835 in.).
3. After resurfacing the seat, inspect for even valve seating, apply a thin film of compound between the valve face and valve seat, and fit them with valve lapping tool.
4. Check the valve seating with prussian blue. The valve seating surface should show good contact all the way around.

**[BX1870D (D722-E4) and BX2370D (D902-E4)]**

Valve seat angle	Factory specification	0.79 rad 45 °
------------------	-----------------------	------------------

**[BX2670D (D1005-E4)]**

Valve seat angle	Factory specification	IN.	1.0 rad 60 °
		EX.	0.79 rad 45 °

- (1) Valve Seat Width
- (2) Identical Dimension

- (A) Check Contact
- (B) Correct Seat Width
- (C) Check Contact
- (a) 0.26 rad (15 °) or 0.52 rad (30 °)
- (b) 0.79 rad (45 °) or 1.0 rad (60 °)
- (c) 0.52 rad (30 °) or 0.26 rad (15 °)

9Y1210855ENS0058US0

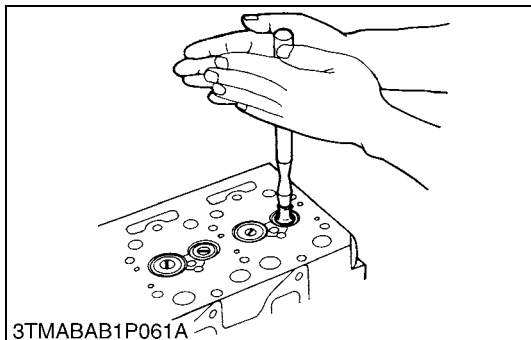

**Valve Lapping**

1. Apply compound evenly to the valve lapping surface.
2. Insert the valve into the valve guide. Lap the valve onto its seat with a valve flapper or screwdriver.
3. After lapping the valve, wash the compound away and apply oil, then repeat valve lapping with oil.
4. Apply prussian blue to the contact surface to check the seated rate. If it is less than 70 %, repeat valve lapping again.

■ **IMPORTANT**

- When valve lapping is performed, be sure to check the valve recessing and adjust the valve clearance after assembling the valve.

9Y1210855ENS0059US0

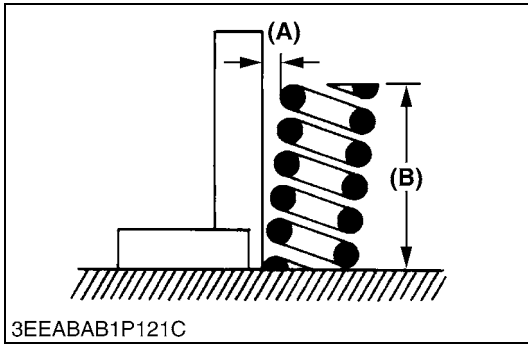

**Free Length and Tilt of Valve Spring**

1. Measure the free length **(B)** of valve spring with vernier calipers. If the measurement is less than the allowable limit, replace it.
2. Put the valve spring on a surface plate, place a square on the side of the valve spring.
3. Check to see if the entire side is in contact with the square. Rotate the valve spring and measure the maximum tilt **(A)**. If the measurement exceeds the allowable limit, replace it.
4. Check the entire surface of the valve spring for scratches. If there is any problem, replace it.

**[BX1870D (D722-E4) and BX2370D (D902-E4)]**

Tilt <b>(A)</b>	Allowable limit	1.2 mm 0.047 in.
Free length <b>(B)</b>	Factory specification	31.3 to 31.8 mm 1.24 to 1.25 in.
	Allowable limit	28.4 mm 1.12 in.

**[BX2670D (D1005-E4)]**

Tilt <b>(A)</b>	Allowable limit	1.0 mm 0.039 in.
Free length <b>(B)</b>	Factory specification	37.0 to 37.5 mm 1.46 to 1.47 in.
	Allowable limit	36.5 mm 1.44 in.

**(A) Tilt**

**(B) Free Length**

9Y1210855ENS0060US0

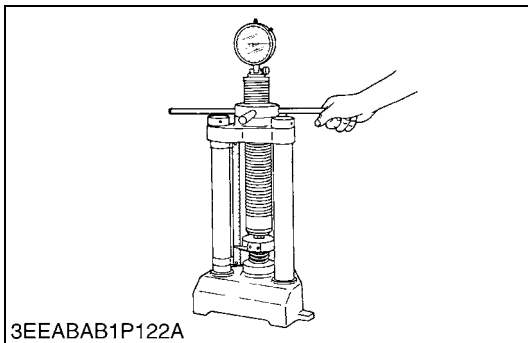

**Valve Spring Setting Load**

1. Place the valve spring on a tester and compress it to the same length it is actually compressed in the engine.
2. Read the compression load on the gauge.
3. If the measurement is less than the allowable limit, replace it.

**[BX1870D (D722-E4) and BX2370D (D902-E4)]**

Setting load / Setting length	Factory specification	65 N / 27.0 mm 6.6 kgf / 27.0 mm 15 lbf / 1.06 in.
	Allowable limit	55 N / 27.0 mm 5.6 kgf / 27.0 mm 12 lbf / 1.06 in.

**[BX2670D (D1005-E4)]**

Setting load / Setting length	Factory specification	117.4 N / 31.0 mm 11.97 kgf / 31.0 mm 26.39 lbf / 1.22 in.
	Allowable limit	100.0 N / 31.0 mm 10.20 kgf / 31.0 mm 22.48 lbf / 1.22 in.

9Y1210855ENS0061US0



**Oil Clearance between Rocker Arm and Rocker Arm Shaft**

1. Measure the rocker arm shaft O.D. with an outside micrometer.
2. Measure the rocker arm I.D. with an inside micrometer, and then calculate the oil clearance.
3. If the oil clearance exceeds the allowable limit, replace the rocker arm and measure the oil clearance again. If it still exceeds the allowable limit, replace also the rocker arm shaft.

**[BX1870D (D722-E4) and BX2370D (D902-E4)]**

Oil clearance between rocker arm and rocker arm shaft	Factory specification	0.016 to 0.045 mm 0.00063 to 0.0017 in.
	Allowable limit	0.15 mm 0.0059 in.
Rocker arm shaft O.D.	Factory specification	10.473 to 10.484 mm 0.41233 to 0.41275 in.
Rocker arm I.D.	Factory specification	10.500 to 10.518 mm 0.41339 to 0.41409 in.

**[BX2670D (D1005-E4)]**

Oil clearance between rocker arm and rocker arm shaft	Factory specification	0.016 to 0.045 mm 0.00063 to 0.0017 in.
	Allowable limit	0.10 mm 0.0039 in.
Rocker arm shaft O.D.	Factory specification	11.973 to 11.984 mm 0.47138 to 0.47181 in.
Rocker arm I.D.	Factory specification	12.000 to 12.018 mm 0.47244 to 0.47314 in.

9Y1210855ENS0062US0

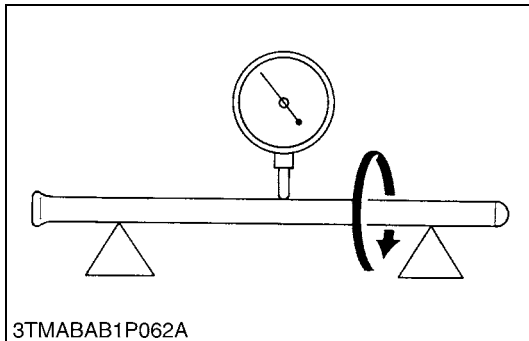

**Push Rod Alignment**

1. Place the push rod on V blocks.
2. Measure the push rod alignment.
3. If the measurement exceeds the allowable limit, replace the push rod.

Push rod alignment	Allowable limit	0.25 mm 0.0098 in.
--------------------	-----------------	-----------------------

9Y1210855ENS0063US0



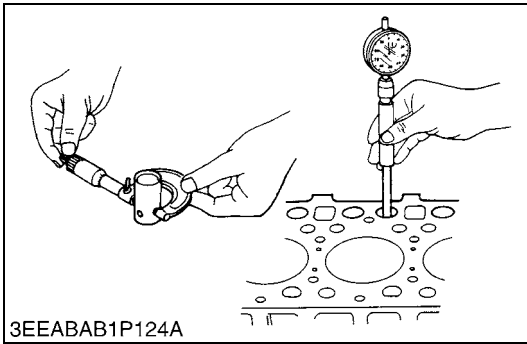

**Oil Clearance between Tappet and Tappet Guide Bore**

1. Measure the tappet O.D. with an outside micrometer.
2. Measure the I.D. of the tappet guide bore with a cylinder gauge, and calculate the oil clearance.
3. If the oil clearance exceeds the allowable limit or the tappet is damaged, replace the tappet.

**[BX1870D (D722-E4) and BX2370D (D902-E4)]**

Oil Clearance between tappet and tappet guide bore	Factory specification	0.016 to 0.052 mm 0.00063 to 0.0020 in.
	Allowable limit	0.10 mm 0.0039 in.
Tappet O.D.	Factory specification	17.966 to 17.984 mm 0.70733 to 0.70803 in.
Tappet guide bore I.D.	Factory specification	18.000 to 18.018 mm 0.70867 to 0.70937 in.

**[BX2670D (D1005-E4)]**

Oil Clearance between tappet and tappet guide bore	Factory specification	0.020 to 0.062 mm 0.00079 to 0.0024 in.
	Allowable limit	0.07 mm 0.003 in.
Tappet O.D.	Factory specification	19.959 to 19.980 mm 0.78579 to 0.78661 in.
Tappet guide bore I.D.	Factory specification	20.000 to 20.021 mm 0.78740 to 0.78822 in.

9Y1210855ENS0064US0

## (2) Timing Gears, Camshaft and Governor Gear

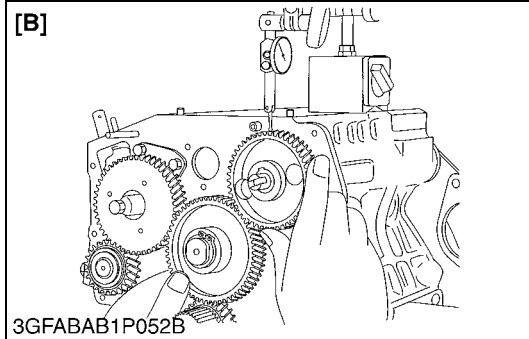

### Timing Gear Backlash

1. Set a dial indicator (lever type) with its tip on the gear tooth.
2. Move the gear to measure the backlash, holding its mating gear.
3. If the backlash exceeds the allowable limit, check the oil clearance of the shafts and the gear.
4. If the oil clearance is proper, replace the gear.

#### [BX1870D (D722-E4) and BX2370D (D902-E4)]

Backlash between idle gear and crank gear	Factory specification	0.0430 to 0.124 mm 0.00170 to 0.00488 in.
	Allowable limit	0.15 mm 0.0059 in.
Backlash between idle gear and cam gear	Factory specification	0.0470 to 0.123 mm 0.00185 to 0.00484 in.
	Allowable limit	0.15 mm 0.0059 in.
Backlash between idle gear and injection pump gear	Factory specification	0.0460 to 0.124 mm 0.00182 to 0.00488 in.
	Allowable limit	0.15 mm 0.0059 in.
Backlash between oil pump drive gear and crank gear	Factory specification	0.0410 to 0.123 mm 0.00162 to 0.00484 in.
	Allowable limit	0.15 mm 0.0059 in.

#### [BX2670D (D1005-E4)]

Backlash between idle gear 1 and crank gear	Factory specification	0.0320 to 0.115 mm 0.00126 to 0.00452 in.
	Allowable limit	0.15 mm 0.0059 in.
Backlash between idle gear 1 and cam gear	Factory specification	0.0360 to 0.114 mm 0.00142 to 0.00448 in.
	Allowable limit	0.15 mm 0.0059 in.
Backlash between idle gear 1 and injection pump gear	Factory specification	0.0340 to 0.116 mm 0.00134 to 0.00456 in.
	Allowable limit	0.15 mm 0.0059 in.

[A] BX1870D (D722-E4) and  
BX2370D (D902-E4)

[B] BX2670D (D1005-E4)

9Y1210855ENS0065US0

### Governor Gear Backlash [BX2670D (D1005-E4) Only]

Backlash between injection pump gear and governor gear	Factory specification	0.0300 to 0.117 mm 0.00119 to 0.00460 in.
	Allowable limit	0.15 mm 0.0059 in.

9Y1210855ENS0066US0

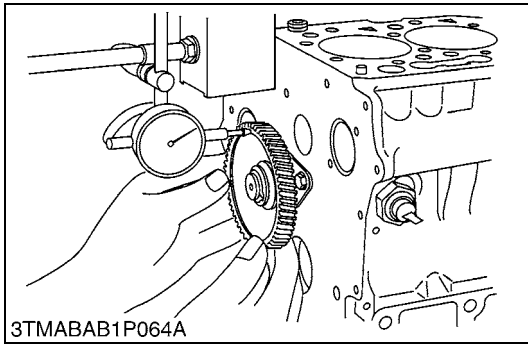

**Idle Gear 1 Side Clearance**

1. Set a dial indicator with its tip on the idle gear.
2. Measure the side clearance by moving the idle gear to the front and rear.
3. If the measurement exceeds the allowable limit, replace the idle gear collar.

Idle gear 1 side clearance	Factory specification	0.20 to 0.51 mm 0.0079 to 0.020 in.
	Allowable limit	0.80 mm 0.031 in.

9Y1210855ENS0067US0

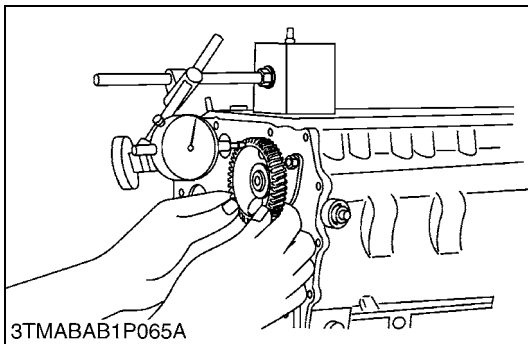

**Camshaft Side Clearance**

1. Set a dial indicator with its tip on the camshaft.
2. Measure the side clearance by moving the cam gear to the front to rear.
3. If the measurement exceeds the allowable limit, replace the camshaft stopper.

**[BX1870D (D722-E4) and BX2370D (D902-E4)]**

Camshaft side clearance	Factory specification	0.15 to 0.31 mm 0.0059 to 0.012 in.
	Allowable limit	0.50 mm 0.020 in.

**[BX2670D (D1005-E4)]**

Camshaft side clearance	Factory specification	0.070 to 0.22 mm 0.0028 to 0.0086 in.
	Allowable limit	0.30 mm 0.012 in.

9Y1210855ENS0068US0

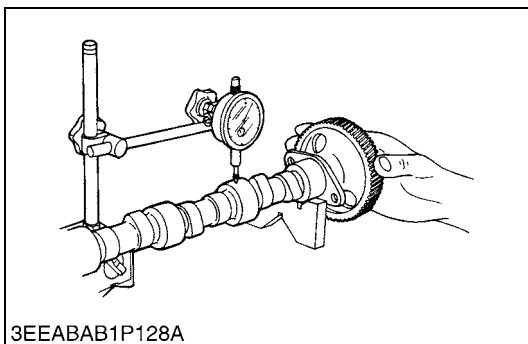

**Camshaft Alignment**

1. Support the camshaft with V blocks on the surface plate at both end journals.
2. Set a dial indicator with its tip on the intermediate journal.
3. Measure the camshaft alignment.
4. If the measurement exceeds the allowable limit, replace the camshaft.

Camshaft alignment	Allowable limit	0.01 mm 0.0004 in.
--------------------	-----------------	-----------------------

9Y1210855ENS0069US0

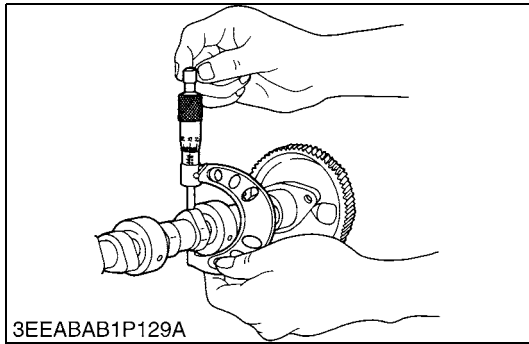

**Cam Height**

1. Measure the height of the cam at its highest point with an outside micrometer.
2. If the measurement is less than the allowable limit, replace the camshaft.

**[BX1870D (D722-E4) and BX2370D (D902-E4)]**

Cam height of intake and exhaust	Factory specification	26.88 mm 1.058 in.
	Allowable limit	26.83 mm 1.056 in.

**[BX2670D (D1005-E4)]**

Cam height of intake	Factory specification	28.80 mm 1.134 in.
	Allowable limit	28.75 mm 1.132 in.
Cam height of exhaust	Factory specification	29.00 mm 1.142 in.
	Allowable limit	28.95 mm 1.140 in.

9Y1210855ENS0070US0

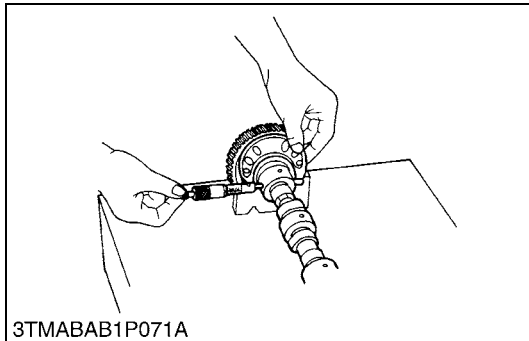

**Oil Clearance of Camshaft Journal**

1. Measure the camshaft journal O.D. with an outside micrometer.
2. Measure the cylinder block bore I.D. for camshaft with a cylinder gauge, and calculate the oil clearance.
3. If the oil clearance exceeds the allowable limit, replace the camshaft.

**[BX1870D (D722-E4) and BX2370D (D902-E4)]**

Oil clearance of camshaft journal	Factory specification	0.050 to 0.091 mm 0.0020 to 0.0035 in.
	Allowable limit	0.15 mm 0.0059 in.
Camshaft journal O.D.	Factory specification	32.934 to 32.950 mm 1.2967 to 1.2972 in.
Camshaft bearing I.D. (Cylinder block bore I.D.)	Factory specification	33.000 to 33.025 mm 1.2993 to 1.3001 in.

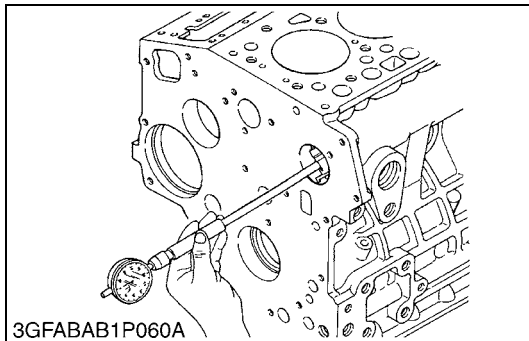

**[BX2670D (D1005-E4)]**

Oil clearance of camshaft journal	Factory specification	0.050 to 0.091 mm 0.0020 to 0.0035 in.
	Allowable limit	0.15 mm 0.0059 in.
Camshaft journal O.D.	Factory specification	35.934 to 35.950 mm 1.4148 to 1.4153 in.
Camshaft bearing I.D. (Cylinder block bore I.D.)	Factory specification	36.000 to 36.025 mm 1.4174 to 1.4183 in.

9Y1210855ENS0071US0

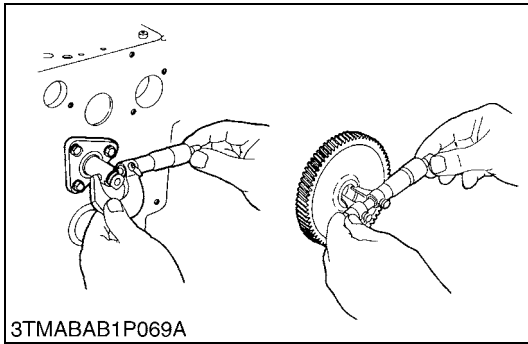

**Oil Clearance between Idle Gear 1 Shaft and Idle Gear Bushing**

1. Measure the idle gear shaft O.D. with an outside micrometer.
2. Measure the idle gear bushing I.D. with an inside micrometer, and calculate the oil clearance.
3. If the oil clearance exceeds the allowable limit, replace the bushing.

If it still exceeds the allowable limit, replace the idle gear shaft.

**[BX1870D (D722-E4) and BX2370D (D902-E4)]**

Oil clearance between idle gear shaft 1 and idle gear bushing	Factory specification	0.020 to 0.084 mm 0.00079 to 0.0033 in.
	Allowable limit	0.10 mm 0.0039 in.
Idle gear shaft 1 O.D.	Factory specification	19.967 to 19.980 mm 0.78611 to 0.78661 in.
Idle gear bushing 1 I.D.	Factory specification	20.000 to 20.051 mm 0.78741 to 0.78940 in.

**[BX2670D (D1005-E4)]**

Oil clearance between idle gear shaft 1 and idle gear bushing	Factory specification	0.020 to 0.054 mm 0.00079 to 0.0021 in.
	Allowable limit	0.10 mm 0.0039 in.
Idle gear shaft 1 O.D.	Factory specification	25.967 to 25.980 mm 1.0224 to 1.0228 in.
Idle gear bushing 1 I.D.	Factory specification	26.000 to 26.021 mm 1.0237 to 1.0244 in.

9Y1210855ENS0072US0

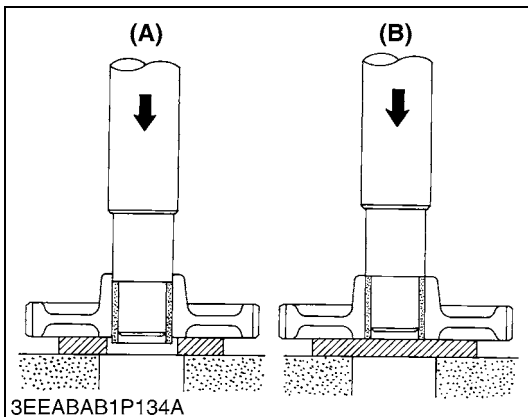

**Replacing Idle Gear Bushing**

**(When removing)**

1. Press out the used idle gear bushing using an idle gear bushing replacing tool. (See page "SPECIAL TOOLS".)

**(When installing)**

1. Clean a new idle gear bushing and idle gear bore, and apply engine oil to them.
2. Press in a new bushing using an idle gear bushing replacing tool, until it is flush with the end of the idle gear.

(A) When Removing

(B) When Removing

9Y1210855ENS0073US0

### (3) Piston and Connecting Rod

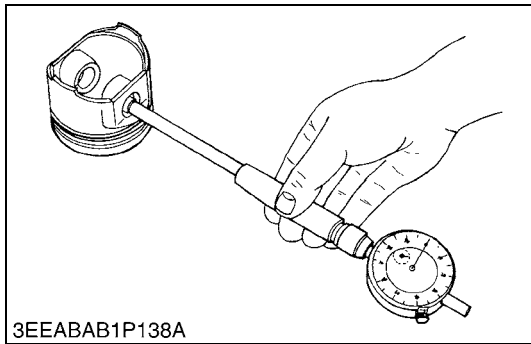

#### Piston Pin Bore I.D.

1. Measure the piston pin bore I.D. in both the horizontal and vertical directions with a cylinder gauge.
2. If the measurement exceeds the allowable limit, replace the piston.

#### **[BX1870D (D722-E4) and BX2370D (D902-E4)]**

Piston pin bore I.D.	Factory specification	20.000 to 20.013 mm 0.78741 to 0.78791 in.
	Allowable limit	20.05 mm 0.7894 in.

#### **[BX2670D (D1005-E4)]**

Piston pin bore I.D.	Factory specification	22.000 to 22.013 mm 0.86615 to 0.86665 in.
	Allowable limit	22.03 mm 0.8673 in.

9Y1210855ENS0074US0

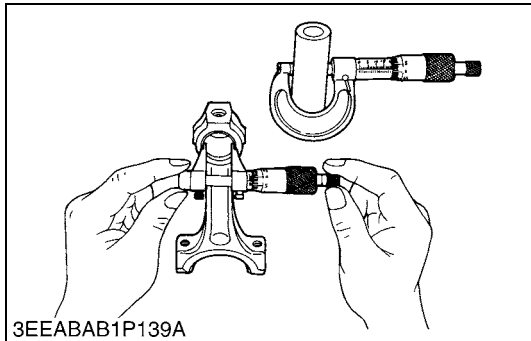

#### Oil Clearance between Piston Pin and Small End Bushing

1. Measure the piston pin O.D. where it contacts the bushing with an outside micrometer.
2. Measure the small end bushing I.D. with an inside micrometer, and calculate the oil clearance.
3. If the oil clearance exceeds the allowable limit, replace the bushing. If it still exceeds the allowable limit, replace the piston pin.

#### **[BX1870D (D722-E4) and BX2370D (D902-E4)]**

Oil clearance between piston pin and small end bushing	Factory specification	0.015 to 0.075 mm 0.00059 to 0.0029 in.
	Allowable limit	0.15 mm 0.0059 in.
Piston pin O.D.	Factory specification	20.002 to 20.011 mm 0.78748 to 0.78783 in.
Small end bushing I.D.	Factory specification	20.025 to 20.040 mm 0.78839 to 0.78897 in.

#### **[BX2670D (D1005-E4)]**

Oil clearance between piston pin and small end bushing	Factory specification	0.014 to 0.038 mm 0.00056 to 0.0014 in.
	Allowable limit	0.15 mm 0.0059 in.
Piston pin O.D.	Factory specification	22.002 to 22.011 mm 0.86622 to 0.86657 in.
Small end bushing I.D.	Factory specification	22.025 to 22.040 mm 0.86713 to 0.86771 in.

9Y1210855ENS0075US0

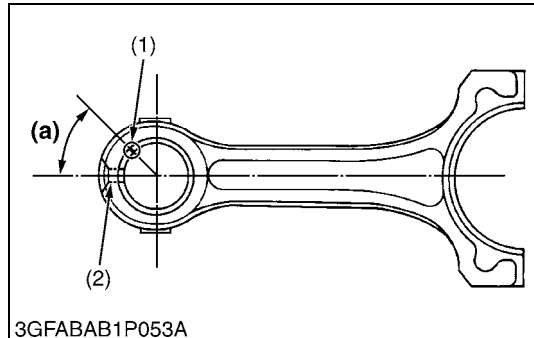
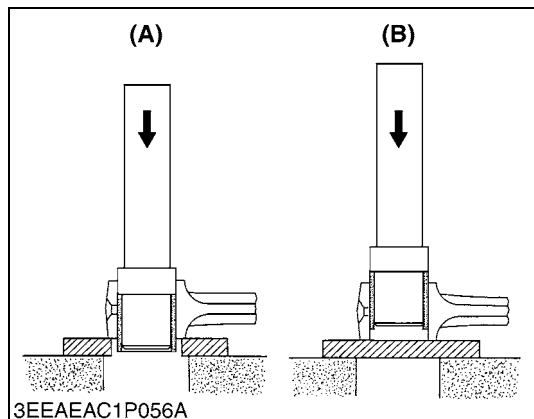

**Replacing Small End Bushing**

**(When removing)**

1. Press out the used bushing using a small end bushing replacing tool. (See page "SPECIAL TOOLS".)

**(When installing)**

1. Clean a new small end bushing and bore, and apply engine oil to them.
2. Using a small end bushing replacing tool, press in a new bushing (service parts) taking due care to see that the connecting rod oil hole matches the bushing hole.

**[BX1870D (D722-E4) and BX2370D (D902-E4)]**

Oil clearance between piston pin and small end bushing (Spare parts)	Factory specification	0.015 to 0.075 mm 0.00059 to 0.0029 in.
	Allowable limit	0.15 mm 0.0059 in.
Small end bushing I.D. (Spare parts)	Factory specification	20.026 to 20.077 mm 0.78843 to 0.79043 in.

**[BX2670D (D1005-E4)]**

Oil clearance between piston pin and small end bushing (Spare parts)	Factory specification	0.015 to 0.038 mm 0.00056 to 0.0014 in.
	Allowable limit	0.15 mm 0.0059 in.
Small end bushing I.D. (Spare parts)	Factory specification	22.025 to 22.040 mm 0.86713 to 0.86771 in.

- (1) Seam
- (2) Oil Hole

- (A) When Removing
- (B) When Installing
- (a) 0.79 rad (45 °)

9Y1210855ENS0076US0

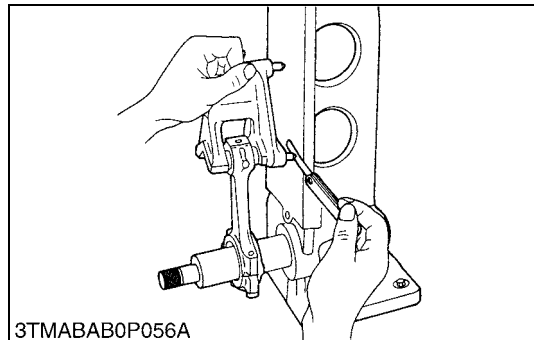

**Connecting Rod Alignment**

**NOTE**

- Since the I.D. of the connecting rod small end bushing is the basis of this check, check bushing for wear beforehand.

1. Install the piston pin into the connecting rod.
2. Install the connecting rod on the connecting rod alignment tool.
3. Put a gauge over the piston pin, and move it against the face plate.
4. If the gauge does not fit squarely against the face plate, measure the space between the pin of the gauge and the face plate.
5. If the measurement exceeds the allowable limit, replace the connecting rod.

Connecting rod alignment	Allowable limit	0.05 mm 0.002 in.
--------------------------	-----------------	----------------------

9Y1210855ENS0077US0

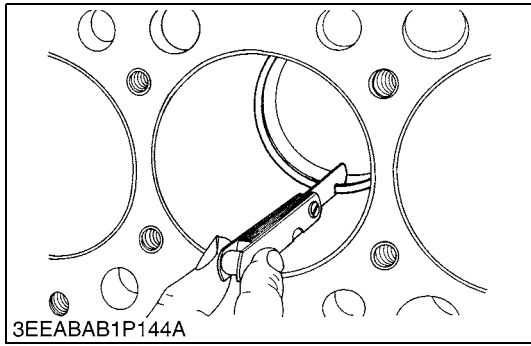

**Piston Ring Gap**

1. Insert the piston ring into the lower part of the cylinder (the least worn out part) with a piston.
2. Measure the ring gap with a thickness gauge.
3. If the measurement exceeds the allowable limit, replace the piston ring.

**[BX1870D (D722-E4)]**

Piston ring gap	Top ring	Factory specification	0.15 to 0.30 mm 0.0059 to 0.011 in.
		Allowable limit	1.20 mm 0.0472 in.
	Second ring	Factory specification	0.30 to 0.45 mm 0.012 to 0.017 in.
		Allowable limit	1.25 mm 0.0492 in.
	Oil ring	Factory specification	0.15 to 0.30 mm 0.0059 to 0.011 in.
		Allowable limit	1.20 mm 0.0472 in.

**[BX2370D (D902-E4)]**

Piston ring gap	Top ring	Factory specification	0.20 to 0.35 mm 0.0079 to 0.013 in.
		Allowable limit	1.25 mm 0.0492 in.
	Second ring	Factory specification	0.35 to 0.50 mm 0.014 to 0.019 in.
		Allowable limit	1.25 mm 0.0492 in.
	Oil ring	Factory specification	0.20 to 0.35 mm 0.0079 to 0.013 in.
		Allowable limit	1.25 mm 0.0492 in.

**[BX2670D (D1005-E4)]**

Piston ring gap	Top ring	Factory specification	0.30 to 0.45 mm 0.012 to 0.017 in.
		Allowable limit	1.25 mm 0.0492 in.
	Second ring	Factory specification	0.30 to 0.45 mm 0.012 to 0.017 in.
		Allowable limit	1.25 mm 0.0492 in.
	Oil ring	Factory specification	0.25 to 0.40 mm 0.0099 to 0.015 in.
		Allowable limit	1.25 mm 0.0492 in.

9Y1210855ENS0078US0



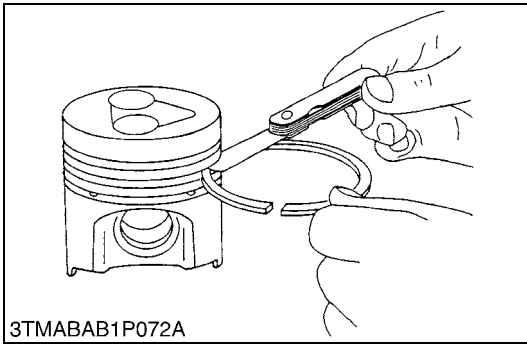

**Clearance between Piston ring and Piston Ring Groove**

1. Clean the rings and the ring grooves, and install each ring in its groove.
2. Measure the clearance between the ring and the groove with a feeler gauge or depth gauge.
3. If the clearance exceeds the allowable limit, replace the piston ring.
4. If the clearance still exceeds the allowable limit with new ring, replace the piston.

**[BX1870D (D722-E4) and BX2370D (D902-E4)]**

Clearance between piston ring and piston ring groove	Second ring	Factory specification	0.0900 to 0.120 mm 0.00355 to 0.00472 in.
		Allowable limit	0.15 mm 0.0059 in.
	Oil ring	Factory specification	0.040 to 0.080 mm 0.0016 to 0.0031 in.
		Allowable limit	0.15 mm 0.0059 in.

**[BX2670D (D1005-E4)]**

Clearance between piston ring and piston ring groove	Second ring	Factory specification	0.0850 to 0.112 mm 0.00335 to 0.00440 in.
		Allowable limit	0.2 mm 0.008 in.
	Oil ring	Factory specification	0.020 to 0.060 mm 0.00079 to 0.0023 in.
		Allowable limit	0.15 mm 0.0059 in.

9Y1210855ENS0079US0

### (4) Crankshaft

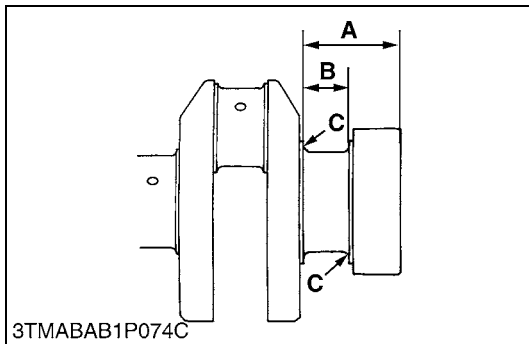
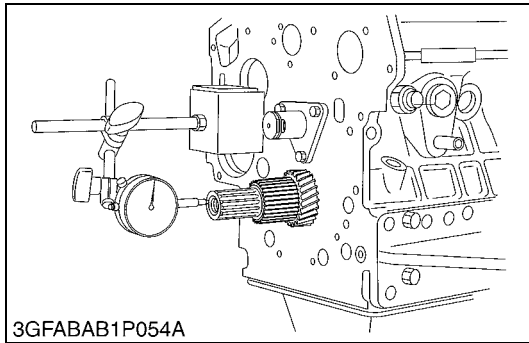

#### Crankshaft Side Clearance

1. Set a dial indicator with its tip on the end of the crankshaft.
2. Measure the side clearance by moving the crankshaft to the front and rear.
3. If the measurement exceeds the allowable limit, replace the thrust bearings.
4. If the same size bearing is useless because of the crankshaft journal wear, replace it with an oversize one referring to the table and figure.

Crankshaft side clearance	Factory specification	0.15 to 0.31 mm 0.0059 to 0.012 in.
	Allowable limit	0.50 mm 0.020 in.

#### (Reference)

#### [BX1870D (D722-E4) and BX2370D (D902-E4)]

- Oversize thrust bearing

Oversize	Bearing	Code Number	Marking
0.20 mm 0.0079 in.	Thrust bearing 1 02	15261-23950	020 OS
	Thrust bearing 2 02	15261-23970	020 OS
0.40 mm 0.016 in.	Thrust bearing 1 04	15261-23960	040 OS
	Thrust bearing 2 04	15261-23980	040 OS

- Oversize dimensions of crankshaft journal

Oversize	0.20 mm 0.0079 in.	0.40 mm 0.016 in.
Dimension A	46.10 to 46.30 mm 1.815 to 1.822 in.	46.30 to 46.50 mm 1.823 to 1.830 in.
Dimension B	23.40 to 23.45 mm 0.9213 to 0.9232 in.	23.80 to 23.85 mm 0.9370 to 0.9389 in.
Dimension C	1.8 to 2.2 mm radius 0.071 to 0.086 in. radius	1.8 to 2.2 mm radius 0.071 to 0.086 in. radius

The crankshaft journal must be fine-finished to higher than Rmax=0.8S.

#### [BX2670D (D1005-E4)]

Oversize	0.20 mm 0.0079 in.	0.40 mm 0.016 in.
Dimension A	51.50 to 51.70 mm 2.028 to 2.035 in.	51.60 to 51.80 mm 2.032 to 2.039 in.
Dimension B	28.20 to 28.25 mm 1.111 to 1.112 in.	28.40 to 28.45 mm 1.119 to 1.120 in.
Dimension C	2.3 to 2.7 mm radius 0.091 to 0.10 in. radius	2.3 to 2.7 mm radius 0.091 to 0.10 in. radius

The crankshaft journal must be fine-finished to higher than Rmax=0.8S.

9Y1210855ENS0080US0

#### Crankshaft Alignment

1. Support the crankshaft with V blocks on the surface plate at both end journals.
2. Set a dial indicator with its tip on the intermediate journal.
3. Measure the crankshaft alignment.
4. If the measurement exceeds the allowable limit, replace the crankshaft.

Crankshaft alignment	Allowable limit	0.02 mm 0.0008 in.
----------------------	-----------------	-----------------------

9Y1210855ENS0081US0

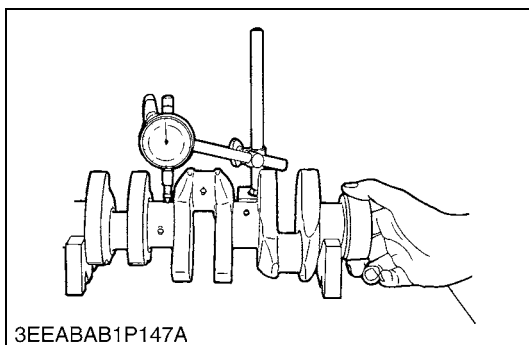

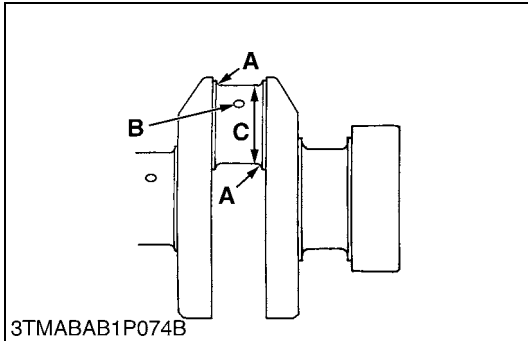
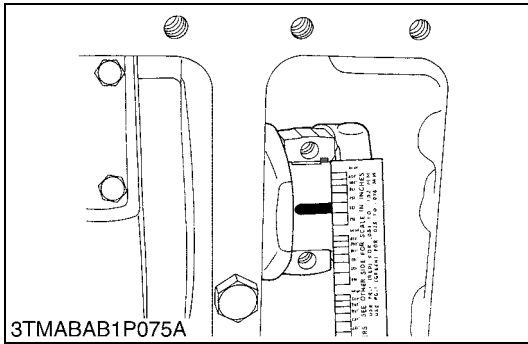

**Oil Clearance between Crankpin and Crankpin Bearing**

1. Clean the crankpin and crankpin bearing.
2. Put a strip of plastigauge on the center of the crankpin.
3. Install the connecting rod cap and tighten the connecting rod screws to the specified torque, and remove the cap again.
4. Measure the amount of the flattening with the scale, and get the oil clearance.
5. If the oil clearance exceeds the allowable limit, replace the crankpin bearing.
6. If the same size bearing is useless because of the crankpin wear, replace it with an undersize one referring to the table and figure.

■ **NOTE**

- Never insert the plastigauge into the crankpin oil hole.
- Be sure not to move the crankshaft while the connecting rod screws are tightened.

**[BX1870D (D722-E4) and BX2370D (D902-E4)]**

Oil clearance between crankpin and crankpin bearing	Factory specification	0.020 to 0.051 mm 0.00079 to 0.0020 in.
	Allowable limit	0.15 mm 0.0059 in.

Crankpin O.D.	Factory specification	33.959 to 33.975 mm 1.3370 to 1.3375 in.
Crankpin bearing I.D.	Factory specification	33.995 to 34.010 mm 1.3384 to 1.3389 in.

**(Reference)**

- Undersize crankpin bearing

Undersize	Bearing	Code Number	Marking
0.20 mm 0.0079 in.	Crankpin bearing 02	15861-22970	020 US
0.40 mm 0.016 in.	Crankpin bearing 04	15861-22980	040 US

- Undersize dimensions of crankpin

Undersize	0.20 mm 0.0079 in.	0.40 mm 0.016 in.
Dimension A	2.3 to 2.7 mm radius 0.091 to 0.10 in. radius	2.3 to 2.7 mm radius 0.091 to 0.10 in. radius
*Dimension B	1.0 to 1.5 mm relief 0.040 to 0.059 in. relief	1.0 to 1.5 mm relief 0.040 to 0.059 in. relief
Dimension C	33.759 to 33.775 mm dia. 1.3291 to 1.3297 in. dia.	33.559 to 33.575 mm dia. 1.3213 to 1.3218 in. dia.

The crankshaft journal must be fine-finished to higher than Rmax=0.8S.  
 \*Holes to be de-burred and edges rounded with 1.0 to 1.5 mm (0.040 to 0.059 in.) relief.

**(To be continued)**

(Continued)

**[BX2670D (D1005-E4)]**

Oil clearance between crankpin and crankpin bearing	Factory specification	0.029 to 0.091 mm 0.0011 to 0.0036 in.
	Allowable limit	0.20 mm 0.0079 in.

Crankpin O.D.	Factory specification	39.959 to 39.975 mm 1.5732 to 1.5738 in.
Crankpin bearing I.D.	Factory specification	40.040 to 40.050 mm 1.5764 to 1.5767 in.

**(Reference)**

- Undersize dimensions of crankpin

Undersize	<b>0.20 mm 0.0079 in.</b>	<b>0.40 mm 0.016 in.</b>
Dimension A	2.8 to 3.2 mm radius 0.11 to 0.12 in. radius	2.8 to 3.2 mm radius 0.11 to 0.12 in. radius
*Dimension B	1.0 to 1.5 mm relief 0.040 to 0.059 in. relief	1.0 to 1.5 mm relief 0.040 to 0.059 in. relief
Dimension C	39.759 to 39.775 mm dia. 1.5654 to 1.5659 in. dia.	39.559 to 39.575 mm dia. 1.5575 to 1.5580 in. dia.

The crankshaft journal must be fine-finished to higher than Rmax=0.8S.  
 \*Holes to be de-burred and edges rounded with 1.0 to 1.5 mm  
 (0.040 to 0.059 in.) relief.

9Y1210855ENS0082US0

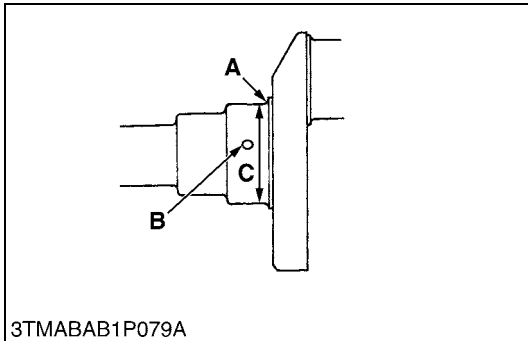
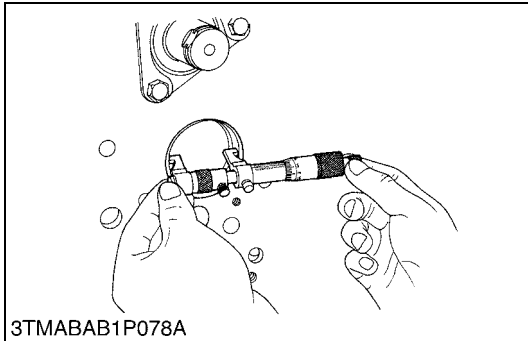
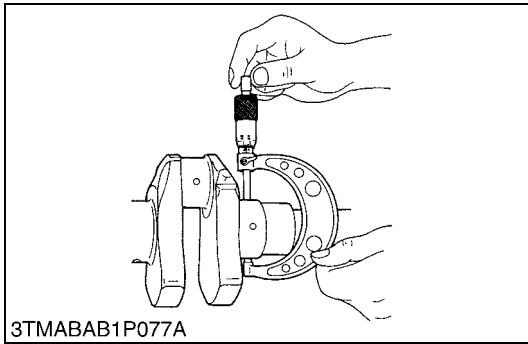

**Oil Clearance between Crankshaft Journal and Crankshaft Bearing 1**

1. Measure the O.D. of the crankshaft front journal with an outside micrometer.
2. Measure the I.D. of the crankshaft bearing 1 with an inside micrometer, and calculate the oil clearance.
3. If the oil clearance exceeds the allowable limit, replace the crankshaft bearing 1.
4. If the same size bearing is useless because of the crankshaft journal wear, replace it with an undersize one referring to the table and the figure.

**[BX1870D (D722-E4) and BX2370D (D902-E4)]**

Oil clearance between crankshaft journal and crankshaft bearing 1	Factory specification	BX1870D (D722-E4)	0.0340 to 0.114 mm 0.00134 to 0.00448 in.
		BX2370D (D902-E4)	0.0340 to 0.106 mm 0.00134 to 0.00417 in.
Allowable limit		0.20 mm 0.0079 in.	

Crankshaft journal O.D.	Factory specification	BX1870D (D722-E4)	39.934 to 39.950 mm 1.5722 to 1.5728 in.
		BX2370D (D902-E4)	43.934 to 43.950 mm 1.7297 to 1.7303 in.
Crankshaft bearing 1 I.D.	Factory specification	BX1870D (D722-E4)	39.984 to 40.040 mm 1.5742 to 1.5763 in.
		BX2370D (D902-E4)	43.984 to 44.040 mm 1.7317 to 1.7338 in.

**(Reference)**

- Undersize crankshaft bearing 1

Undersize	Models	Bearing	Code Number	Marking
0.20 mm 0.0079 in.	BX1870D (D722-E4)	Crankshaft bearing 1 02	15861-23910	020 US
	BX2370D (D902-E4)		1G460-23910	
0.40 mm 0.016 in.	BX1870D (D722-E4)	Crankshaft bearing 1 04	15861-23920	040 US
	BX2370D (D902-E4)		1G4601-23920	

Undersize	Models	0.20 mm 0.0079 in.	0.40 mm 0.016 in.
Dimension A	All models	1.8 to 2.2 mm radius 0.071 to 0.086 in. radius	1.8 to 2.2 mm radius 0.071 to 0.086 in. radius
*Dimension B	All models	1.0 to 1.5 mm relief 0.040 to 0.059 in. relief	1.0 to 1.5 mm relief 0.040 to 0.059 in. relief
Dimension C	BX1870D (D722-E4)	39.734 to 39.750 mm dia. 1.5644 to 1.5649 in. dia.	39.534 to 39.550 mm dia. 1.5565 to 1.5570 in. dia.
	BX2370D (D902-E4)	43.734 to 43.750 mm dia. 1.7219 to 1.7224 in. dia.	43.534 to 43.550 mm dia. 1.7140 to 1.7145 in. dia.

The crankshaft journal must be fine-finished to higher than Rmax=0.8S.  
 \*Holes to be de-burred and edges rounded with 1.0 to 1.5 mm (0.040 to 0.059 in.) relief.

**(To be continued)**

(Continued)

**[BX2670D (D1005-E4)]**

Oil clearance between crankshaft journal and crankshaft bearing 1	Factory specification	0.0340 to 0.114 mm 0.00134 to 0.00448 in.
	Allowable limit	0.20 mm 0.0079 in.

Crankshaft journal O.D.	Factory specification	47.934 to 47.950 mm 1.8872 to 1.8877 in.
Crankshaft bearing 1 I.D.	Factory specification	47.984 to 48.048 mm 1.8892 to 1.8916 in.

**(Reference)**

- Undersize dimensions of crankshaft journal

Undersize	0.20 mm 0.0079 in.	0.40 mm 0.016 in.
Dimension A	2.3 to 2.7 mm radius 0.091 to 0.10 in. radius	2.3 to 2.7 mm radius 0.091 to 0.10 in. radius
*Dimension B	1.0 to 1.5 mm relief 0.040 to 0.059 in. relief	1.0 to 1.5 mm relief 0.040 to 0.059 in. relief
Dimension C	47.734 to 47.750 mm dia. 1.8793 to 1.8799 in. dia.	47.534 to 47.550 mm dia. 1.8715 to 1.8720 in. dia.

The crankshaft journal must be fine-finished to higher than Rmax=0.8S.  
\*Holes to be de-burred and edges rounded with 1.0 to 1.5 mm (0.040 to 0.059 in.) relief.

9Y1210855ENS0083US0

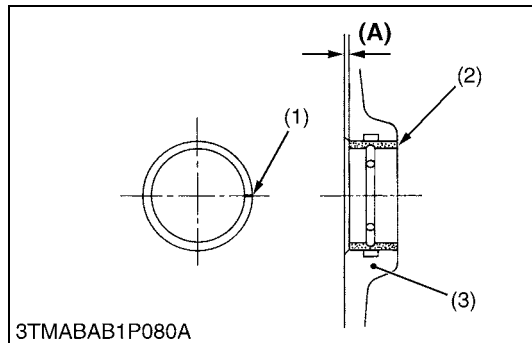

**Replacing Crankshaft Bearing 1**

**(When removing)**

1. Press out the used crankshaft bearing 1 using a crankshaft bearing 1 replacing tool. (See page "SPECIAL TOOLS".)

**(When installing)**

1. Clean a new crankshaft bearing 1 and crankshaft journal bore, and apply engine oil to them.
2. Using a crankshaft bearing 1 replacing tool, press in a new bearing 1 (2) so that its seam (1) directs toward the exhaust manifold side. (See figure.)

Dimension (A)	Factory specification	0 to 0.3 mm 0 to 0.01 in.
---------------	-----------------------	------------------------------

- (1) Seam
- (2) Crankshaft Bearing 1
- (3) Cylinder Block

**(A) Dimension**

9Y1210855ENS0084US0

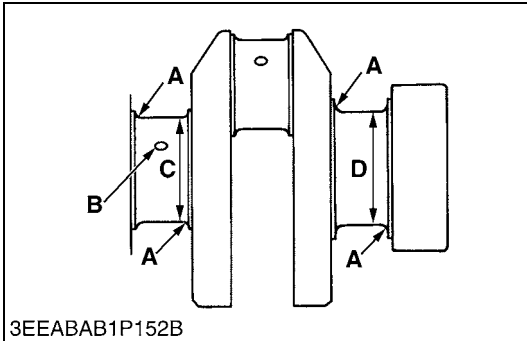
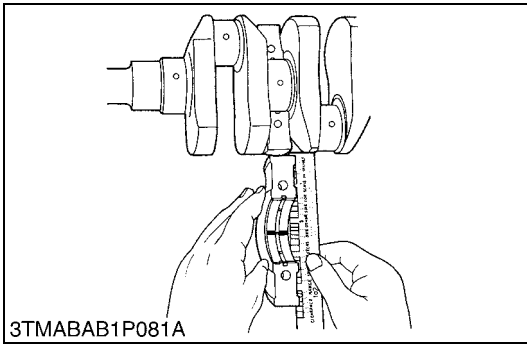

**Oil Clearance between Crankshaft Journal and Crankshaft Bearing 2 and Crankshaft Bearing 3**

1. Put a strip of plastigauge on the center of the journal.
2. Install the bearing case and tighten the bearing case screws 1 to the specified torque, and remove the bearing case again.
3. Measure the amount of the flattening with the scale and get the oil clearance.
4. If the oil clearance exceeds the allowable limit, replace the crankshaft bearing 2 (crankshaft bearing 3).
5. If the same size bearing is useless because of the crankshaft journal wear, replace it with an undersize one referring to the table and figure.

■ **NOTE**

- **Be sure not to move the crankshaft while the bearing case screws are tightened.**

**[BX1870D (D722-E4) and BX2370D (D902-E4)]**

Oil clearance between crankshaft journal and crankshaft bearing 2 (crankshaft bearing 3)	Factory specification	0.028 to 0.059 mm 0.0011 to 0.0023 in.
	Allowable limit	0.20 mm 0.0079 in.

Crankshaft journal O.D. (Flywheel side)	Factory specification	43.934 to 43.950 mm 1.7297 to 1.7303 in.
Crankshaft bearing 2 I.D.	Factory specification	43.978 to 43.993 mm 1.7315 to 1.7320 in.

Crankshaft journal O.D. (Intermediate)	Factory specification	BX1870D (D722-E4)	39.934 to 39.950 mm 1.5722 to 1.5728 in.
		BX2370D (D902-E4)	43.934 to 43.950 mm 1.7297 to 1.7303 in.
Crankshaft bearing 3 I.D.	Factory specification	BX1870D (D722-E4)	39.978 to 39.993 mm 1.5740 to 1.5745 in.
		BX2370D (D902-E4)	43.978 to 43.993 mm 1.7315 to 1.7320 in.

**(To be continued)**

**(Continued)**

**(Reference)**

- Undersize crankshaft bearing 2 and 3 (0.20 mm (0.0079 in.))

Models	Bearing	Code Number	Marking
BX1870D (D722-E4)	Crankshaft bearing 2 02	15694-23930	020 US
	Crankshaft bearing 3 02	15861-23860	
BX2370D (D902-E4)	Crankshaft bearing 2 02	1G460-23930	
	Crankshaft bearing 3 02	1G460-23940	

- Undersize crankshaft bearing 2 and 3 (0.40 mm (0.016 in.))

Models	Bearing	Code Number	Marking
BX1870D (D722-E4)	Crankshaft bearing 2 04	15694-23940	040 US
	Crankshaft bearing 3 04	15861-23870	
BX2370D (D902-E4)	Crankshaft bearing 2 04	1G460-23950	
	Crankshaft bearing 3 04	1G460-23960	

- Undersize dimensions of crankshaft journal

Undersize	Models	0.20 mm 0.0079 in.	0.40 mm 0.016 in.
Dimension <b>A</b>	All models	1.8 to 2.2 mm radius 0.071 to 0.086 in. radius	1.8 to 2.2 mm radius 0.071 to 0.086 in. radius
*Dimension <b>B</b>	All models	1.0 to 1.5 mm relief 0.040 to 0.059 in. relief	1.0 to 1.5 mm relief 0.040 to 0.059 in. relief
Dimension <b>C</b>	BX1870D (D722-E4)	39.734 to 39.750 mm dia. 1.5644 to 1.5649 in. dia.	39.534 to 39.550 mm dia. 1.5565 to 1.5570 in. dia.
	BX2370D (D902-E4)	43.734 to 43.750 mm dia. 1.7219 to 1.7224 in. dia.	43.534 to 43.550 mm dia. 1.7140 to 1.7145 in. dia.

The crankshaft journal must be fine-finished to higher than Rmax=0.8S.  
 \*Holes to be de-burred and edges rounded with 1.0 to 1.5 mm  
 (0.040 to 0.059 in.) relief.

**(To be continued)**



(Continued)

**[BX2670D (D1005-E4)]**

Oil clearance between crankshaft journal and crankshaft bearing 2	Factory specification	0.034 to 0.095 mm 0.0014 to 0.0037 in.
	Allowable limit	0.20 mm 0.0079 in.

Crankshaft journal O.D. (Intermediate)	Factory specification	47.934 to 47.950 mm 1.8872 to 1.8877 in.
--	-----------------------	---

Crankshaft bearing 2 I.D.	Factory specification	47.984 to 48.029 mm 1.8892 to 1.8909 in.
---------------------------	-----------------------	---

Oil clearance between crankshaft journal and crankshaft bearing 3	Factory specification	0.034 to 0.098 mm 0.0013 to 0.0038 in.
	Allowable limit	0.20 mm 0.0079 in.

Crankshaft journal O.D. (Flywheel side)	Factory specification	51.921 to 51.940 mm 2.0442 to 2.0448 in.
---	-----------------------	---

Crankshaft bearing 3 I.D.	Factory specification	51.974 to 52.019 mm 2.0463 to 2.0479 in.
---------------------------	-----------------------	---

**(Reference)**

- Undersize dimensions of crankshaft journal

Undersize	<b>0.20 mm 0.0079 in.</b>	<b>0.40 mm 0.16 in.</b>
Dimension A	2.3 to 2.7 mm radius 0.091 to 0.10 in. radius	2.3 to 2.7 mm radius 0.091 to 0.10 in. radius
*Dimension B	1.0 to 1.5 mm relief 0.040 to 0.0591 in. relief	1.0 to 1.5 mm relief 0.040 to 0.0591 in. relief
Dimension C	47.734 to 47.750 mm dia. 1.8793 to 1.8799 in. dia.	47.534 to 47.550 mm dia. 1.8715 to 1.8720 in. dia.
Dimension D	51.721 to 51.740 mm dia. 2.0362 to 2.0370 in. dia.	51.521 to 51.540 mm dia. 2.0284 to 2.0291 in. dia.

The crankshaft journal must be fine-finished to higher than Rmax=0.8S.  
\*Holes to be de-burred and edges rounded with 1.0 to 1.5 mm (0.040 to 0.059 in.) relief.

9Y1210855ENS0085US0

## (5) Cylinder

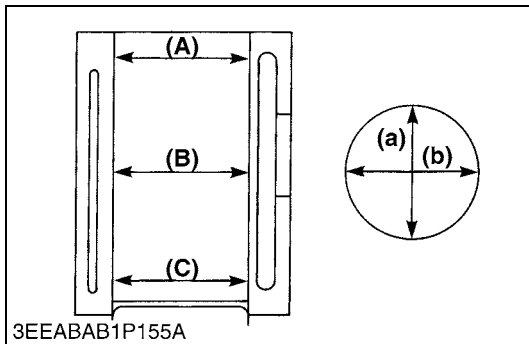
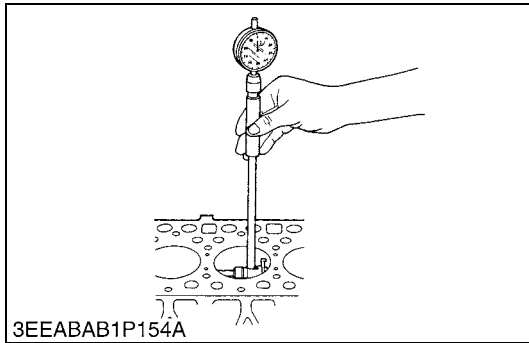

### Cylinder Wear

1. Measure the I.D. of the cylinder at the six positions (see figure) with a cylinder gauge to find the maximum and minimum I.D.'s.
2. Get the difference (Maximum wear) between the maximum and the minimum I.D.'s.
3. If the wear exceeds the allowable limit, bore and hone to the oversize dimension. (Refer to "**Correcting Cylinder**".)
4. Visually check the cylinder wall for scratches. If deep scratches are found, the cylinder should be bored. (Refer to "**Correcting Cylinder**".)

Cylinder liner I.D.	Factory specification	BX1870D (D722-E4)	67.000 to 67.019 mm 2.6378 to 2.6385 in.
		BX2370D (D902-E4)	72.000 to 72.019 mm 2.8347 to 2.8353 in.
		BX2670D (D1005-E4)	76.000 to 76.019 mm 2.9922 to 2.9928 in.
	Allowable limit	BX1870D (D722-E4)	67.150 mm 2.6437 in.
		BX2370D (D902-E4)	72.150 mm 2.8406 in.
		BX2670D (D1005-E4)	76.15 mm 2.998 in.

- (A) Top  
(B) Middle  
(C) Bottom (Skirt)

- (a) Right-angled to Piston Pin  
(b) Piston Pin Direction

9Y1210855ENS0086US0

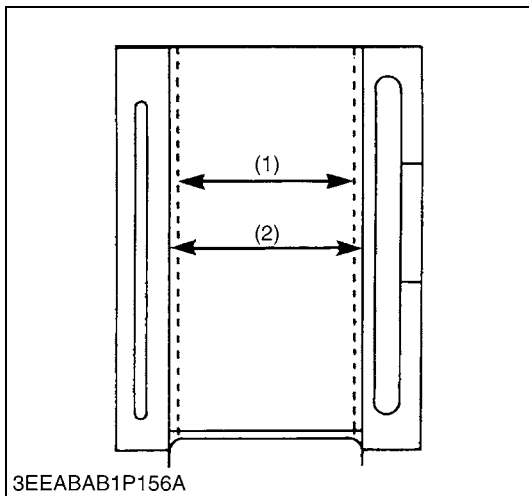

### Correcting Cylinder (Oversize)

1. When the cylinder is worn beyond the allowable limit, bore and hone it to the specified dimension.

Cylinder liner I.D.	Factory specification	BX1870D (D722-E4)	67.250 to 67.269 mm 2.6477 to 2.6483 in.
		BX2370D (D902-E4)	72.250 to 72.269 mm 2.8445 to 2.8452 in.
		BX2670D (D1005-E4)	76.500 to 76.519 mm 3.0119 to 3.0125 in.
	Allowable limit	BX1870D (D722-E4)	67.400 mm 2.6535 in.
		BX2370D (D902-E4)	72.400 mm 2.8504 in.
		BX2670D (D1005-E4)	76.65 mm 3.018 in.
Finishing	Hone to 2.2 to 3.0 µm Rz (87 to 110 µin. Rz)		

2. Replace the piston and piston rings with oversize ones.  
Oversize: 0.25 mm (0.0098 in.)  
Marking: 025

#### NOTE

- When the oversize cylinder is worn beyond the allowable limit, replace the cylinder block with a new one.

- (1) Cylinder I.D. (Before Correction)    (2) Cylinder I.D. (Oversize)

9Y1210855ENS0087US0

## (6) Oil Pump

### [A] BX1870D (D722-E4) and BX2370D (D902-E4)



#### Rotor Lobe Clearance

1. Measure the clearance between lobes of the inner rotor and the outer rotor with a thickness gauge.
2. If the clearance exceeds the factory specifications, replace the oil pump rotor assembly.

Rotor lobe clearance	Factory specification	0.030 to 0.14 mm 0.0012 to 0.0055 in.
----------------------	-----------------------	--

9Y1210855ENS0088US0



#### Clearance between Outer Rotor and Pump Body

1. Measure the clearance between the outer rotor and the pump body with a thickness gauge.
2. If the clearance exceeds the factory specifications, replace the oil pump rotor assembly.

Clearance between outer rotor and pump body	Factory specification	0.070 to 0.15 mm 0.0028 to 0.0059 in.
---	-----------------------	--

9Y1210855ENS0089US0

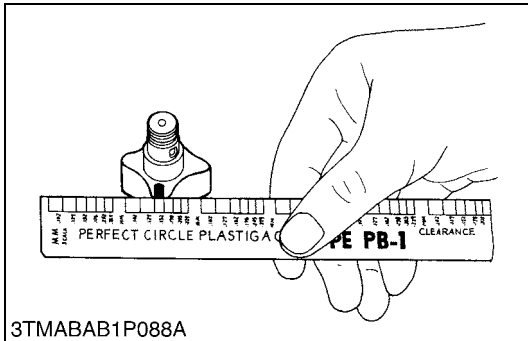

#### Clearance between Rotor and Cover

1. Put a strip of plastigauge onto the rotor face with grease.
2. Install the cover and tighten the screws.
3. Remove the cover carefully, and measure the amount of the flattening with the scale and get the clearance.
4. If the clearance exceeds the factory specifications, replace oil pump rotor assembly.

Clearance between rotor and cover	Factory specification	0.0750 to 0.135 mm 0.00296 to 0.00531 in.
-----------------------------------	-----------------------	--

9Y1210855ENS0090US0

**[B] BX2670D (D1005-E4)**

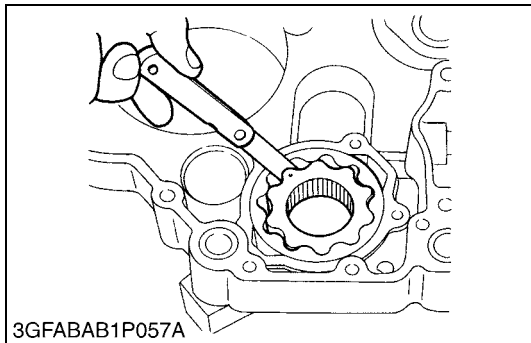

**Rotor Lobe Clearance**

1. Measure the clearance between lobes of the inner rotor and the outer rotor with a feeler gauge.
2. If the clearance exceeds the factory specifications, replace the oil pump rotor assembly.

Rotor lobe clearance	Factory specification	0.060 to 0.18 mm 0.0024 to 0.0071 in.
----------------------	-----------------------	--

9Y1210855ENS0091US0

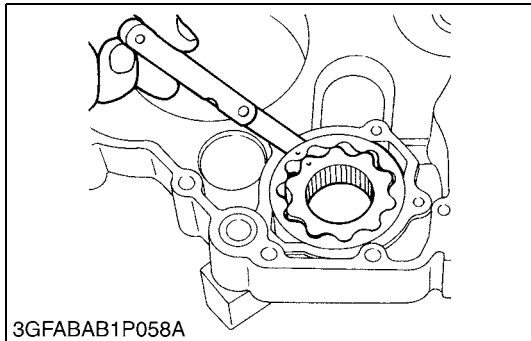

**Clearance between Outer Rotor and Pump Body**

1. Measure the clearance between the outer rotor and the pump body with a feeler gauge.
2. If the clearance exceeds the factory specifications, replace the oil pump rotor assembly.

Clearance between outer rotor and pump body	Factory specification	0.100 to 0.180 mm 0.00394 to 0.00708 in.
---	-----------------------	---

9Y1210855ENS0092US0

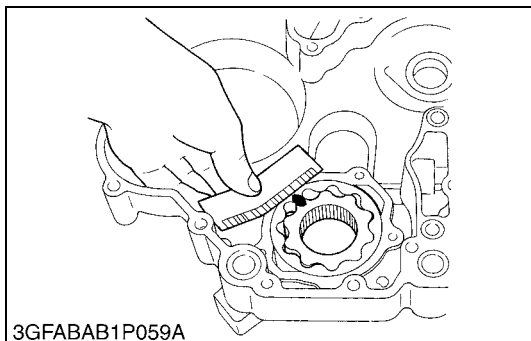

**Clearance between Rotor and Cover**

1. Put a strip of plastigauge onto the rotor face with grease.
2. Install the cover and tighten the screws.
3. Remove the cover carefully, and measure the amount of the flattening with the scale and get the clearance.
4. If the clearance exceeds the factory specifications, replace the oil pump rotor assembly.

Clearance between rotor and cover	Factory specification	0.025 to 0.075 mm 0.00099 to 0.0029 in.
-----------------------------------	-----------------------	--

9Y1210855ENS0093US0

## (7) Relief Valve Spring

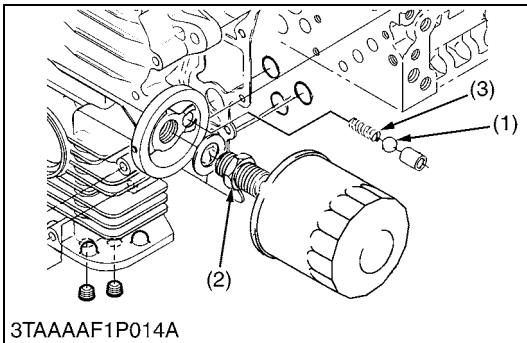
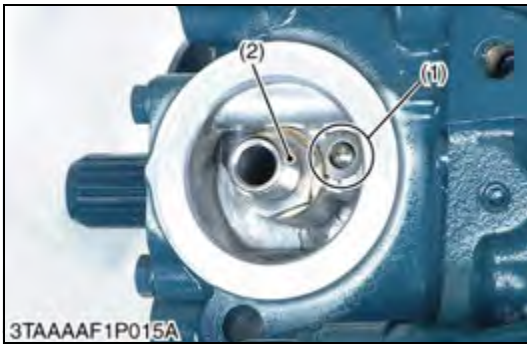

### Relief Valve

1. Remove the oil filter base.
2. Check the relief valve for dirt, and the seat and ball for damage.
3. If damaged, replace.
4. Check the free length of spring.
5. If less than the allowable limit, replace.

Relief valve spring	Factory specification	32 mm 1.26 in.
	Allowable limit	28 mm 1.10 in.

Tightening torque	Joint	40 to 49 N·m 4.0 to 5.0 kgf·m 29 to 36 lbf·ft
-------------------	-------	---

- (1) Relief Valve  
(2) Joint

- (3) Spring

9Y1210855ENS0008US0

# **2 TRANSAXLE**

# MECHANISM

## CONTENTS

1. STRUCTURE.....	2-M1
2. TRAVELING SYSTEM.....	2-M2
[1] HYDROSTATIC TRANSMISSION .....	2-M2
(1) Structure .....	2-M2
(2) Oil Flow.....	2-M3
(3) HST Control Linkage .....	2-M8
(4) Speed Set Linkage .....	2-M9
[2] RANGE GEAR SHIFT SECTION .....	2-M11
[3] FRONT WHEEL DRIVE SECTION .....	2-M11
[4] DIFFERENTIAL GEAR SECTION .....	2-M12
(1) Differential Gears.....	2-M12
(2) Differential Lock.....	2-M13
[5] BRAKE SECTION .....	2-M14
3. PTO SYSTEM.....	2-M15
[1] PTO CLUTCH AND VALVE .....	2-M15
[2] MID AND REAR PTO SECTION .....	2-M18
4. OTHERS.....	2-M19
[1] HYDRAULIC PUMP DRIVE GEAR SECTION .....	2-M19

# 1. STRUCTURE

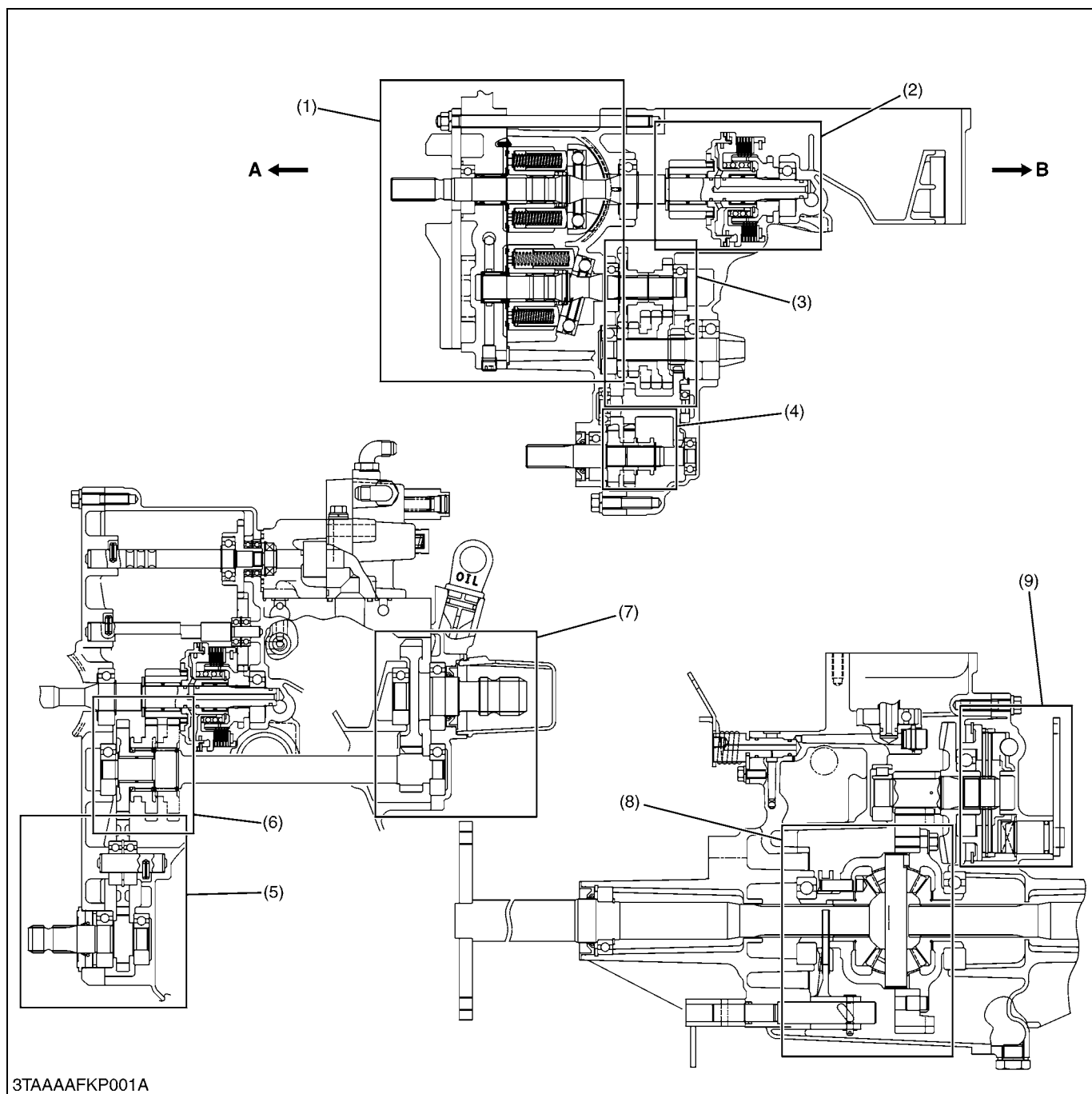

3TAAAFKP001A

- |                              |                                    |                               |                      |
|------------------------------|------------------------------------|-------------------------------|----------------------|
| (1) Hydrostatic Transmission | (4) Front Wheel Drive Gear Section | (6) PTO Gear Shift Section    | <b>A: Front Side</b> |
| (2) PTO Clutch Section       | (5) Mid-PTO Section                | (7) Rear PTO Section          | <b>B: Rear Side</b>  |
| (3) Range Gear Shift Section |                                    | (8) Differential Gear Section |                      |
|                              |                                    | (9) Brake Section             |                      |

9Y1210855TXM0001US0



## 2. TRAVELING SYSTEM

### [1] HYDROSTATIC TRANSMISSION

#### (1) Structure

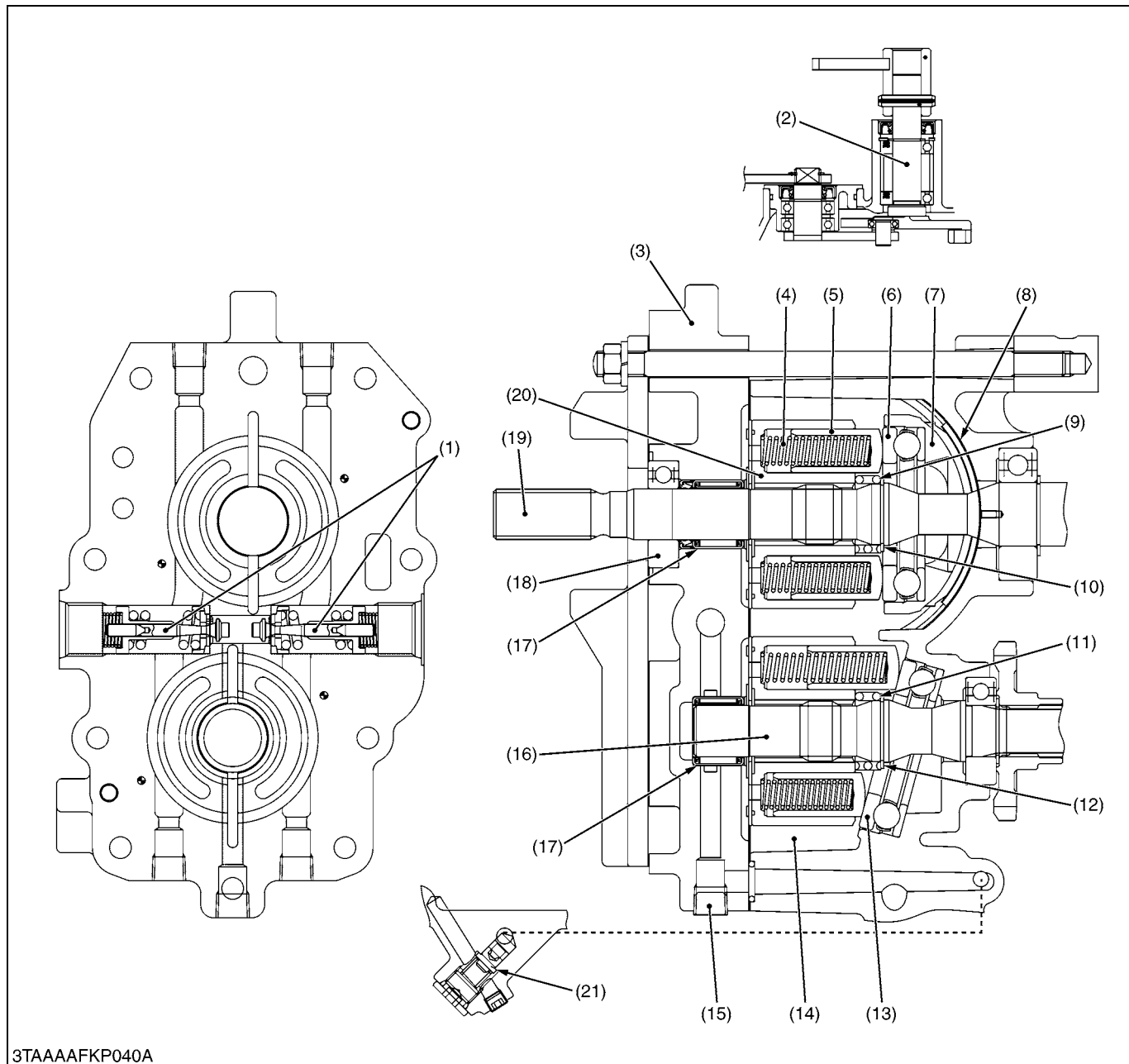

3TAAAFKP040A

- |  |                         |                             |                            |
|--|-------------------------|-----------------------------|----------------------------|
| (1) Check and High Pressure Relief Valve | (6) Thrust Ball Bearing | (12) Circlip                | (17) Needle Bearing        |
| (2) Trunnion Arm                         | (7) Swashplate          | (13) Thrust Ball Bearing    | (18) Ball Bearing          |
| (3) Center Section                       | (8) Cradle Bearing      | (14) Cylinder Block (Motor) | (19) Pump Shaft            |
| (4) Piston Spring                        | (9) Spring              | (15) Plug                   | (20) Cylinder Block (Pump) |
| (5) Piston                               | (10) Circlip            | (16) Motor Shaft            | (21) Charge Relief Valve   |
|  | (11) Spring             |                             |                            |

The hydrostatic transmission consists of variable displacement piston pump, fixed displacement piston motor and valve system.

9Y1210855TXM0002US0

## (2) Oil Flow

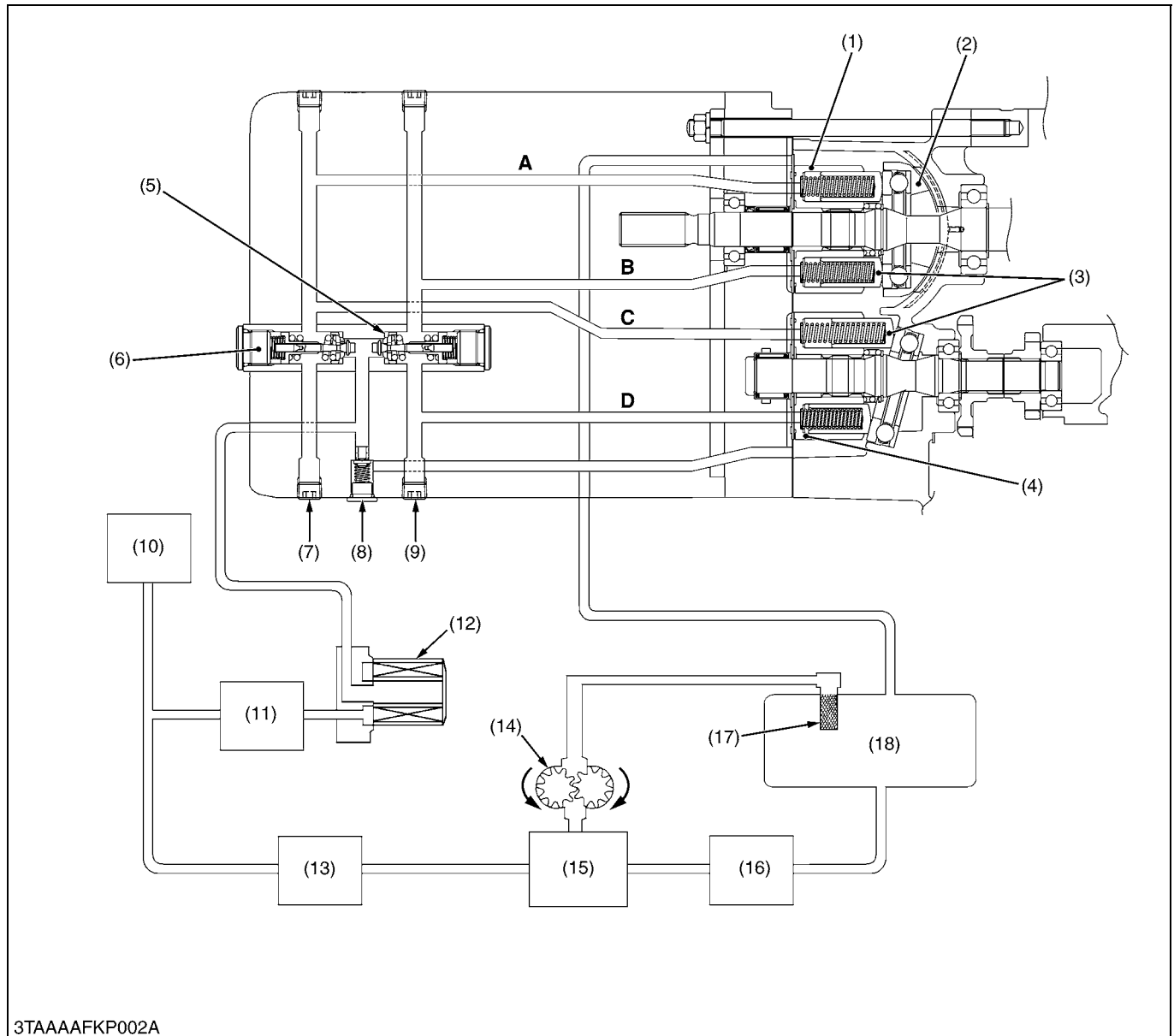

3TAAAFKP002A

- |  |  |  |                  |
|--|--|--|------------------|
| (1) Cylinder Block (Pump)                          | (7) High Pressure Relief Port Plug (Forward) | (13) Power Steering Controller                     | <b>A: A Port</b> |
| (2) Swashplate                                     | (8) Charge Relief Valve                      | (14) Hydraulic Pump                                | <b>B: B Port</b> |
| (3) Piston   | (9) High Pressure Relief Port Plug (Reverse) | (15) Flow Priority Valve (Hydraulic Control Valve) | <b>C: C Port</b> |
| (4) Cylinder Block (Motor)                         | (10) PTO Clutch Valve                        | (16) Position Control Valve                        | <b>D: D Port</b> |
| (5) Check and High Pressure Relief Valve (Forward) | (11) PTO Relief Valve                        | (17) Oil Strainer                                  |                  |
| (6) Check and High Pressure Relief Valve (Reverse) | (12) Oil Filter Cartridge                    | (18) Transmission Case                             |                  |

The pump and motor are joined in a closed hydraulic loop and most of oil circulates within the main oil circuit. A little oil lubricates and oozes out from the clearance between the moving parts of the case. Then oil in the main oil circuit of the HST needs to be supplied a want.

The oil from the power steering circuit flows into the HST for charging.

The charge oil aids smooth operation of pistons for pump and motor. The charge oil passes through the oil filter cartridge to charge relief valve port. The rest of oil passes through the charge relief valve into the HST housing. And overflow oil from HST housing return to the transmission case.

9Y1210855TXM0003US0





**Reverse**

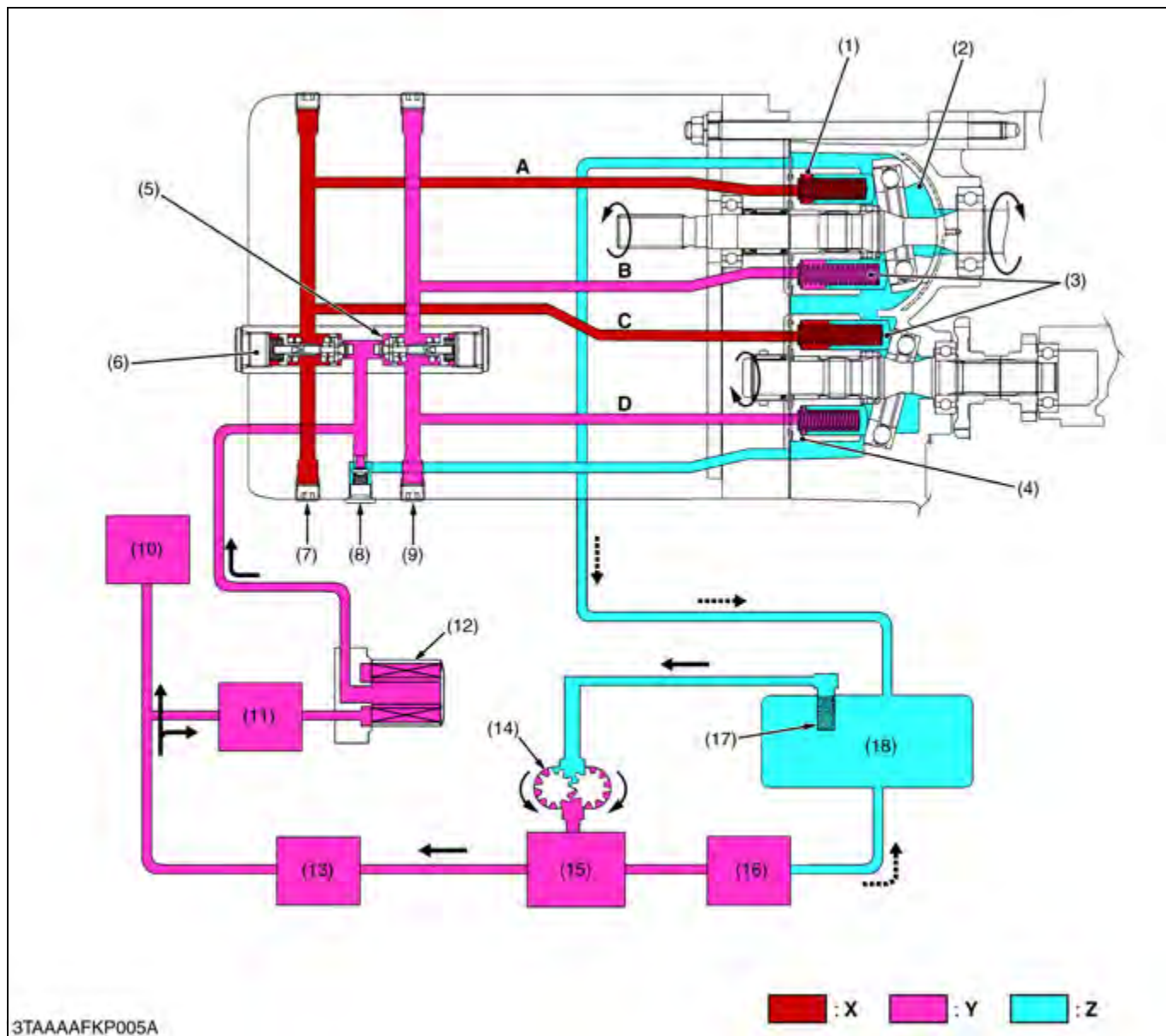

- |  |  |  |                         |
|--|--|--|-------------------------|
| (1) Cylinder Block (Pump)                          | (7) High Pressure Relief Port Plug (Forward) | (13) Power Steering Controller                     | <b>A: A Port</b>        |
| (2) Swashplate                                     | (8) Charge Relief Valve                      | (14) Hydraulic Pump                                | <b>B: B Port</b>        |
| (3) Piston   | (9) High Pressure Relief Port Plug (Reverse) | (15) Flow Priority Valve (Hydraulic Control Valve) | <b>C: C Port</b>        |
| (4) Cylinder Block (Motor)                         | (10) PTO Clutch Valve                        | (16) Position Control Valve                        | <b>D: D Port</b>        |
| (5) Check and High Pressure Relief Valve (Forward) | (11) PTO Relief Valve                        | (17) Oil Strainer                                  | <b>X: High Pressure</b> |
| (6) Check and High Pressure Relief Valve (Reverse) | (12) Oil Filter Cartridge                    | (18) Transmission Case                             | <b>Y: Low Pressure</b>  |
|  |  |  | <b>Z: Free Oil</b>      |

When the speed control pedal is stepped on and in reverse, the variable swashplate is tilted as shown in figure above.

As the pump cylinder block rotates with the input shaft, oil is forced out of pump port A at high pressure. As pressure oil enters motor port C, the pistons, which align with port C, are pushed against the swashplate and slide down the inclined surface.

Then the output shaft rotates with the motor cylinder block. This drives the machine rearward and the angle of pump swashplate determines the output shaft speed.

As the motor cylinder block continues to rotate, oil is forced out of motor port D at low pressure and returns to the pump.

9Y1210855TXM0006US0





### (3) HST Control Linkage

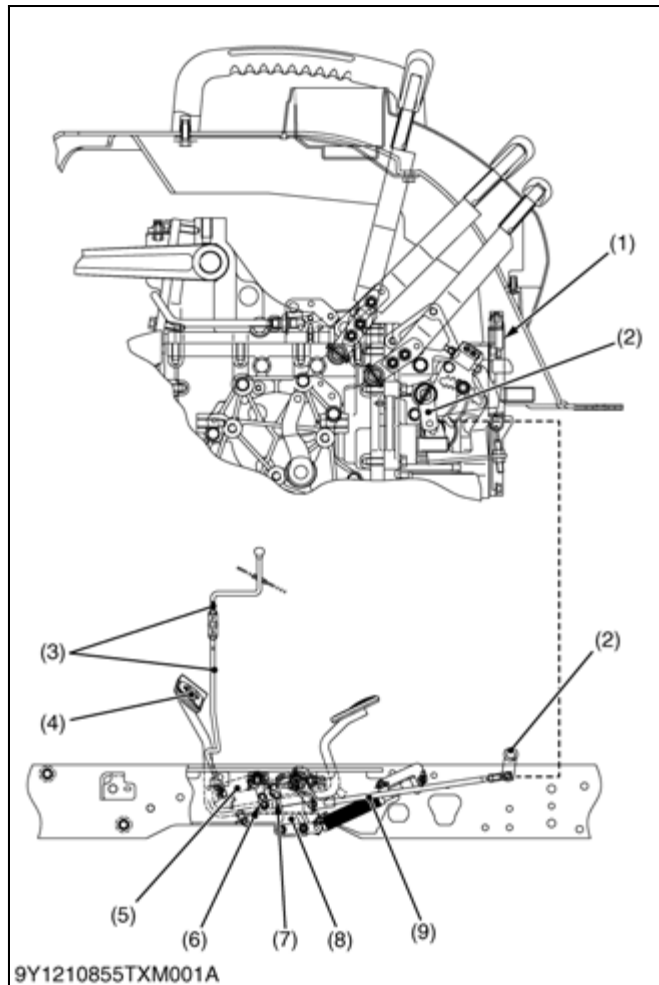

The speed control pedal (4) and the trunnion arm are linked with the HST pedal link (8) and the speed change rod (9). As the front of the pedal is depressed, the swashplate connected to the trunnion arm (2) rotates and forward travelling speed increases. Depressing the rear end increases reverse speed.

The trunnion arm (2) is returned to neutral position by the neutral arm and the tension of neutral spring. At the same time, the swashplate is returned to neutral, when the pedal is released. The damper (10) connected to the HST pedal link (8) restricts the movement of the linkage to prevent abrupt operation or reversing.

Moreover, the feeling of the dynamic braking can be adjusted by changing the arm (11) position of damper (10).

**(Reference)**

**[A]** Force of the damper is large.

**[B]** Force of the damper is small.

**■ NOTE**

- The cruise control system is an optional for BX1870D.

- |                         |                      |
|-------------------------|----------------------|
| (1) Neutral Spring      | (7) Cruise Lock      |
| (2) Trunnion Arm        | (8) HST Pedal Link   |
| (3) Cruise Rod          | (9) Speed Change Rod |
| (4) Speed Control Pedal | (10) Damper          |
| (5) Cruise Arm          | (11) Arm             |
| (6) Cruise Lock         |                      |

9Y1210855TXM0008US0

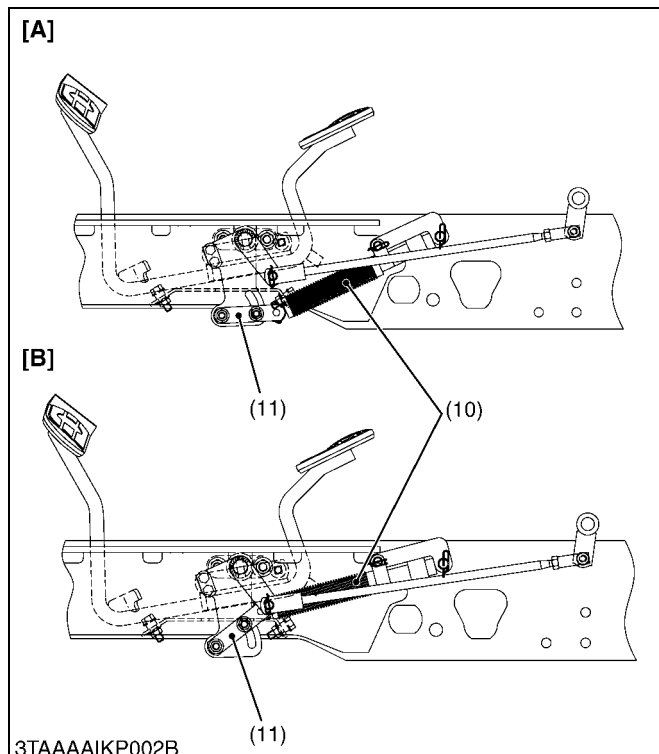

### (4) Speed Set Linkage

#### Speed Set

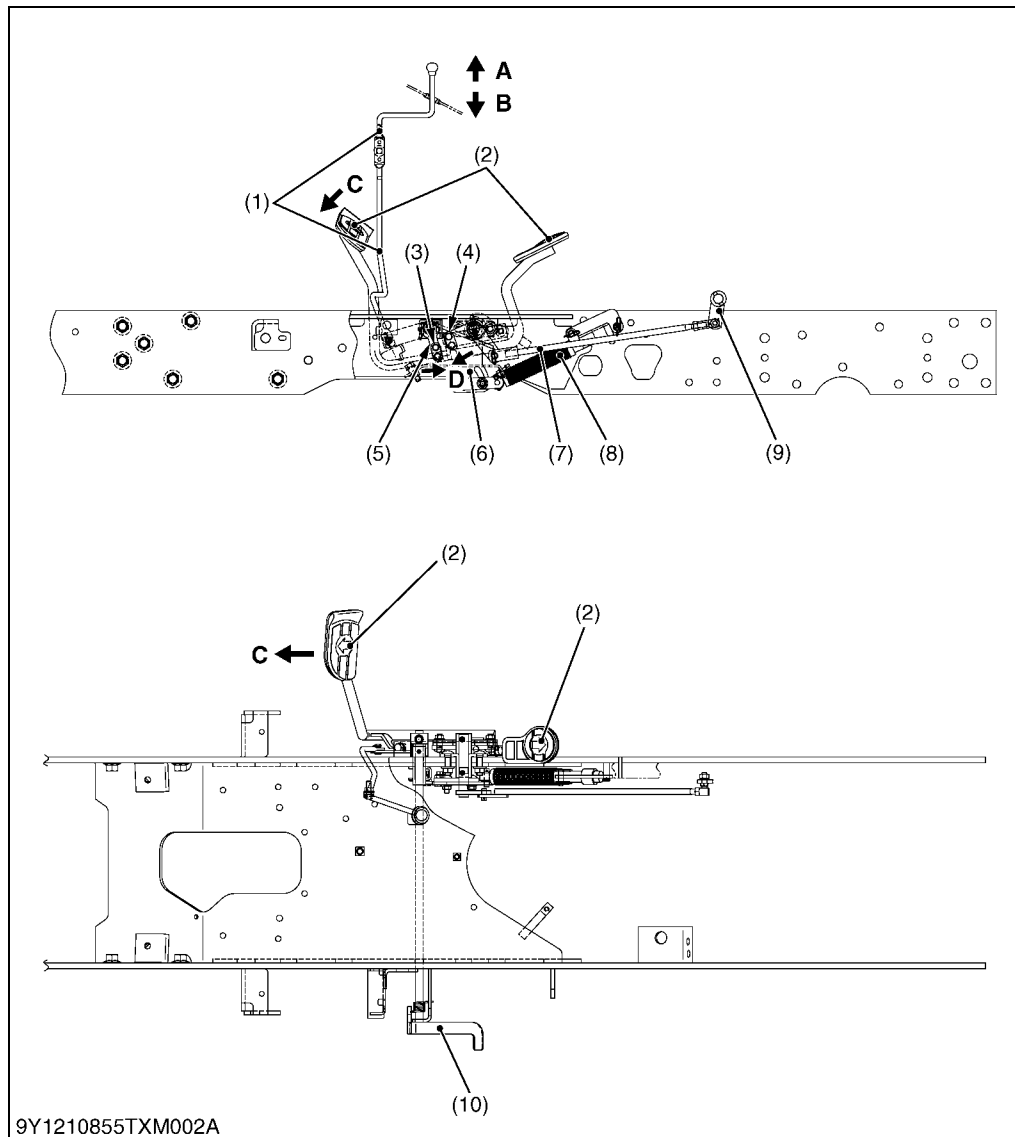

- (1) Speed Set Rod
- (2) Speed Control Pedal
- (3) Cruise Lock
- (4) Cruise Lock
- (5) Cruise Plate
- (6) HST Pedal Link
- (7) Speed Change Rod
- (8) Damper
- (9) Trunnion Arm
- (10) Release Plate

- A:** Speed Set Rod "OFF"
- B:** Speed Set Rod "ON"
- C:** Speed Control Pedal "Forward"
- D:** Cruise Lock "Locked"

9Y1210855TXM002A

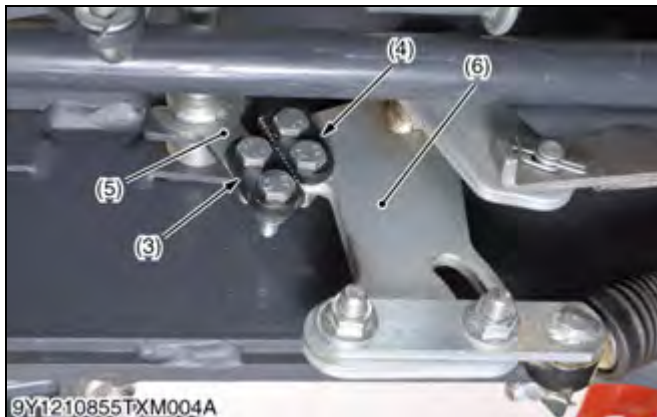

9Y1210855TXM004A

When pushing and holding the speed set rod (1) and depressing the speed control pedal (2), the desired speed is set.

When pushing the speed set rod (1), the cruise plate (5) is rotated counter clockwise.

When depressing the speed control pedal (2) forward, the HST pedal link clockwise.

Since both the cruise lock (3) of the cruise plate (5) and the cruise lock (4) of HST pedal link (6) are locked, the speed control pedal (2) is held at a selected position.

9Y1210855TXM0009US0





**When the Brake Pedal is Depressed**

When the brake pedal (2) is depressed, the release plate (1) located under the brake pedal (2) is pushed down.

Since the cruise plate (3) rotates, the cruise lock (4) and (6) between the cruise plate (3) and the HST pedal link (5) are released.

- (1) Release Plate
- (2) Brake Pedal
- (3) Cruise Plate
- (4) Cruise Lock
- (5) HST Pedal Link
- (6) Cruise Lock

- A: Brake Pedal "Depressed"**
- B: Release Plate "Pushed Down"**
- C: Cruise Plate "Rotates Clockwise" and Release the Cruise Locks**

9Y1210855TXM0010US0

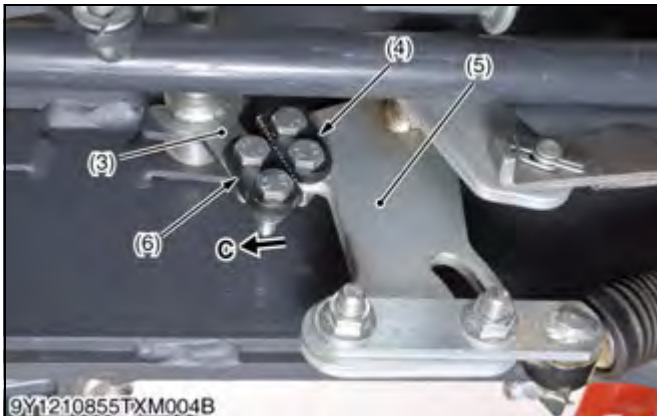
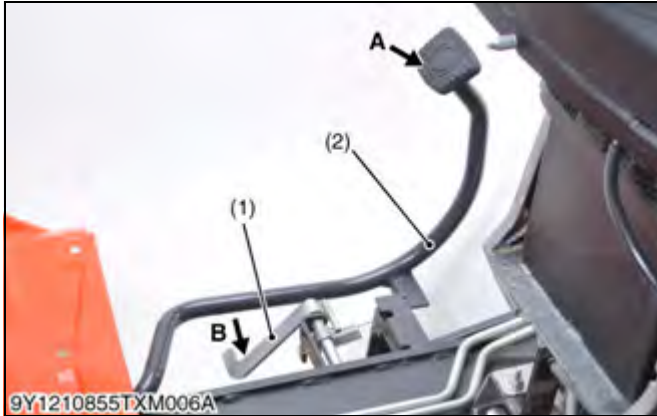

## [2] RANGE GEAR SHIFT SECTION

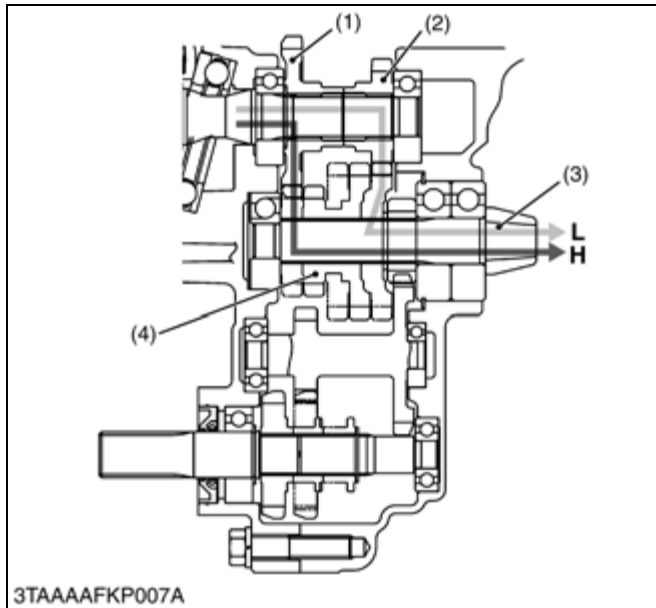

Two kinds of power flow are selected by operating the range gear shift lever to shift the 16T-24T shifter gear (4) on the spiral bevel gear shaft (3).

■ **Low Range**

17T Gear Shaft (2) → Shifter Gear (24T) (4) → Spiral Bevel Pinion Shaft (3).

■ **High Range**

25T Gear (1) → Shifter Gear (16T) (4) → Spiral Bevel Pinion Shaft (3).

- (1) 25T Gear
- (2) 17T Gear
- (3) Spiral Bevel Pinion Shaft
- (4) 16T-24T Shifter Gear

**L: Low Range**  
**H: High Range**

9Y1210855TXM0011US0

## [3] FRONT WHEEL DRIVE SECTION

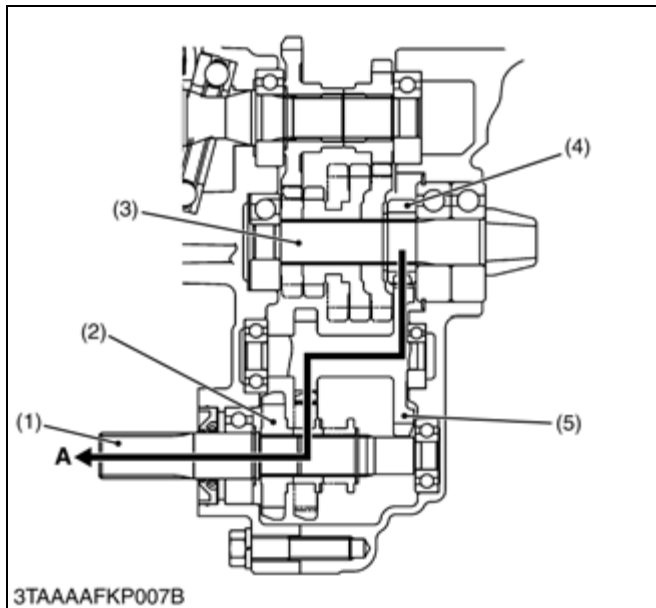

2-wheel drive or 4-wheel drive is selected by changing the position of 19T shifter gear (2) with the front wheel drive lever.

■ **Front Wheel Drive "Disengaged"**

When the front wheel drive lever is set to "Disengaged" position, the 19T shifter gear (2) is neutral and power is not transmitted to the front wheel drive shaft (1).

■ **Front Wheel Drive "Engaged"**

When the front wheel drive lever is set to "Engaged" position, the 19T shifter gear (2) slides to the right to engage with 13T-25T gear shaft (5). Therefore, the power from spiral bevel pinion shaft (3) is transmitted to the front wheel drive shaft (1) through the gears.

- (1) Front Wheel Drive Shaft
- (2) 19T Shifter Gear
- (3) Spiral Bevel Pinion Shaft
- (4) 12T Gear
- (5) 13T-25T Gear Shaft

**A: Front Wheel Drive "Engaged"**

9Y1210855TXM0012US0

## [4] DIFFERENTIAL GEAR SECTION

### (1) Differential Gears

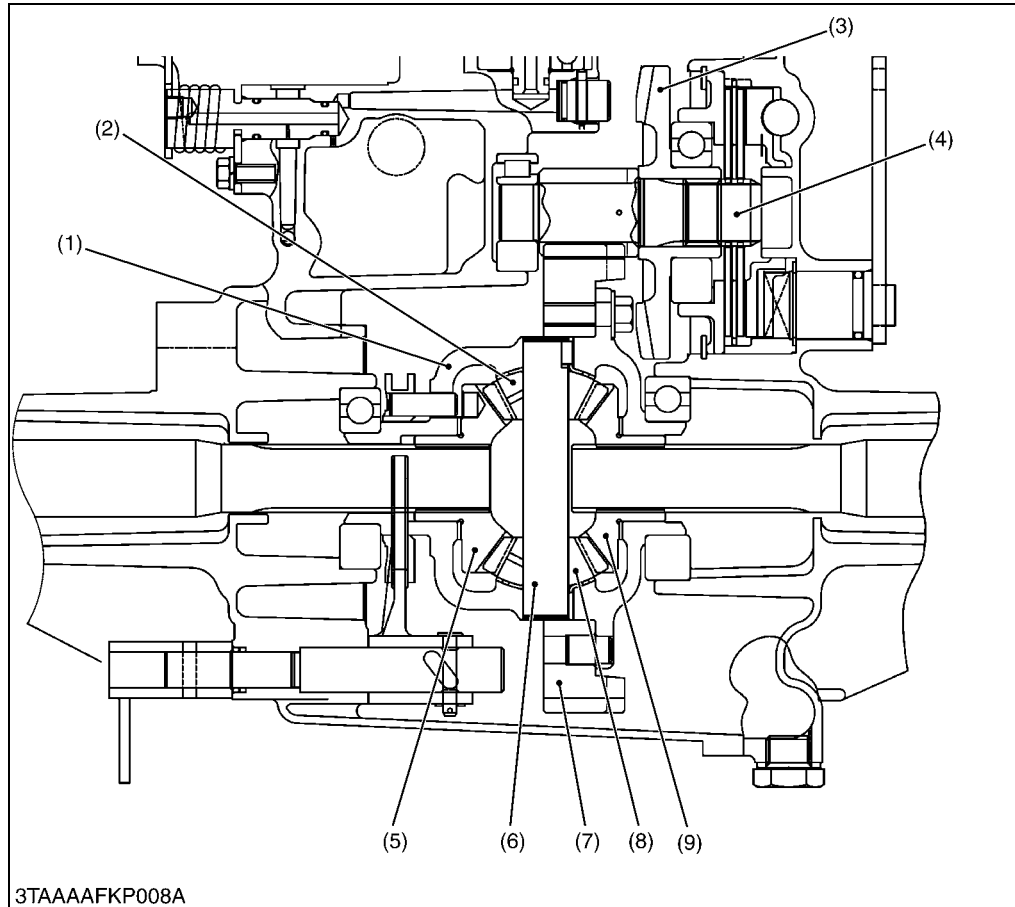

- (1) Differential Case
- (2) Differential Pinion
- (3) 37T Spiral Bevel Gear
- (4) 10T Final Gear Shaft
- (5) Differential Side Gear
- (6) Differential Pinion Shaft
- (7) 66T Final Gear
- (8) Differential Pinion
- (9) Differential Side Gear

#### 1. During Straight Running

Rotation of the spiral bevel pinion is transmitted to the 37T spiral bevel gear (3), 10T final gear shaft (4), 66T final gear (7) and differential case (1). When road resistance to the right and left wheels are equal, differential pinions (2), (8) and differential side gears (5), (9) all rotate as a unit. Both rear axles received equal input, and both wheels turn at the same speed, allowing the tractor to go straight ahead.

At this time, differential pinions (2), (8) do not rotate around the differential pinion shaft (6).

#### 2. During Turning

When the tractor turns, the road resistance to the inside tire increases. In other words, if one of tires slows down, revolution difference is generated in the differential side gears (5), (9). When rotation of one differential side gear becomes lower than the other, differential pinions (2), (8) begin rotating around differential pinion shaft (6). The other differential side gear is increased in speed by the speed increment of differential pinion shaft (6). This means that rotation of one rear axle is slowed down and that of the other rear axle is increased. Thus, the tractor turn smoothly without power loss.

The combined number of revolutions of the right and left differential side gears is always twice that of the spiral bevel gear (3). When spiral bevel gear revolution is  $100 \text{ min}^{-1}$  (rpm), and if one of the differential side gears stops moving, the revolution of the other differential side gear becomes  $200 \text{ min}^{-1}$  (rpm) and if one rotates at  $50 \text{ min}^{-1}$  (rpm), the other rotates at  $150 \text{ min}^{-1}$  (rpm).

9Y1210855TXM0013US0

## (2) Differential Lock

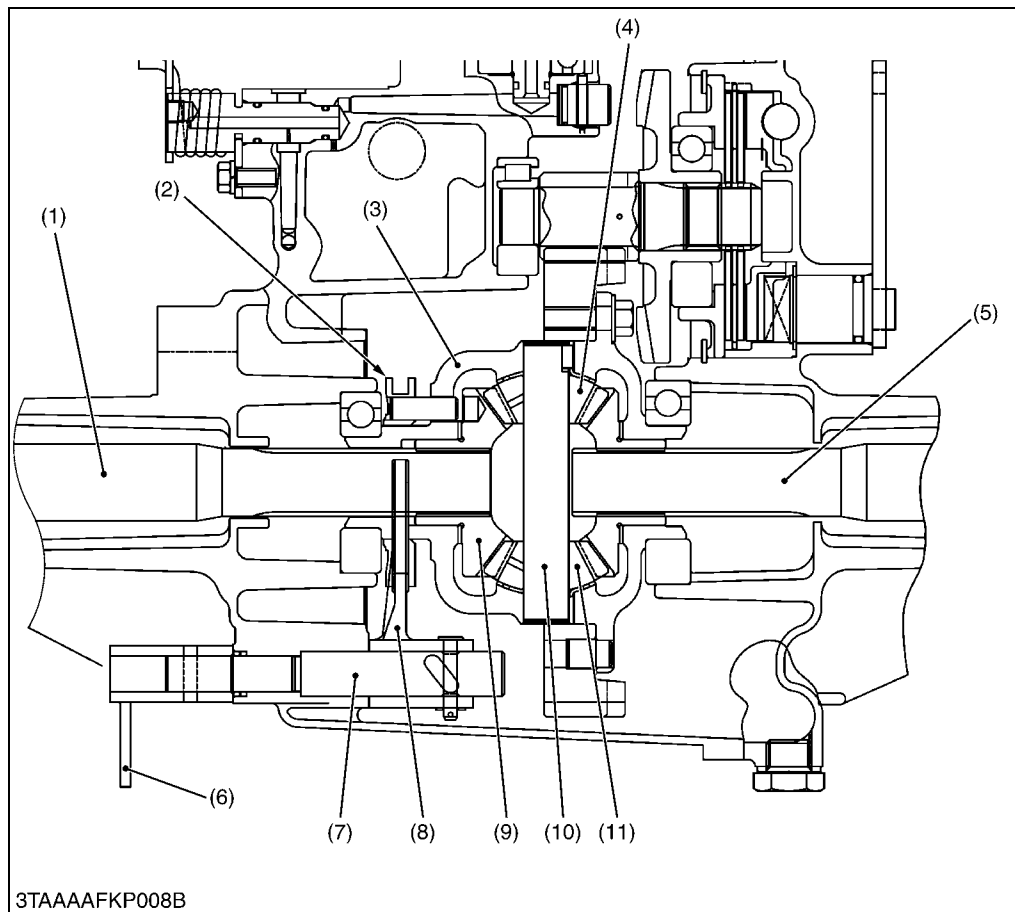

- (1) Rear Axle
- (2) Differential Lock Shifter
- (3) Differential Case
- (4) Differential Pinion
- (5) Rear Axle
- (6) Differential Lock Arm
- (7) Differential Lock Shaft
- (8) Differential Lock Shift Fork
- (9) Differential Side Gear
- (10) Differential Pinion Shaft
- (11) Differential Pinion

When resistance to the right and left tires are greatly different due to ground conditions or type of work, the tire with less resistance slips and prevents the tractor from moving ahead. To compensate for this drawback, the differential lock restricts the differential action and causes both rear axles to rotate as a unit.

When the differential lock pedal is stepped on, it causes the differential lock arm (6) and differential lock shaft (7) to rotate, which will move the differential lock shift fork (8) and the differential lock shifter (2) toward the differential side gear (9). The pins on the differential lock shifter (2) go into the holes in the differential case (3) to cause the differential case (3), differential lock shifter (2) and differential side gear (9) to rotate as a unit.

Therefore, differential pinions (4), (11) are unable to rotate around differential pinion shaft (10) and identical revolutions are transmitted to the right and left rear axle (1), (5).

9Y1210855TXM0014US0

## [5] BRAKE SECTION

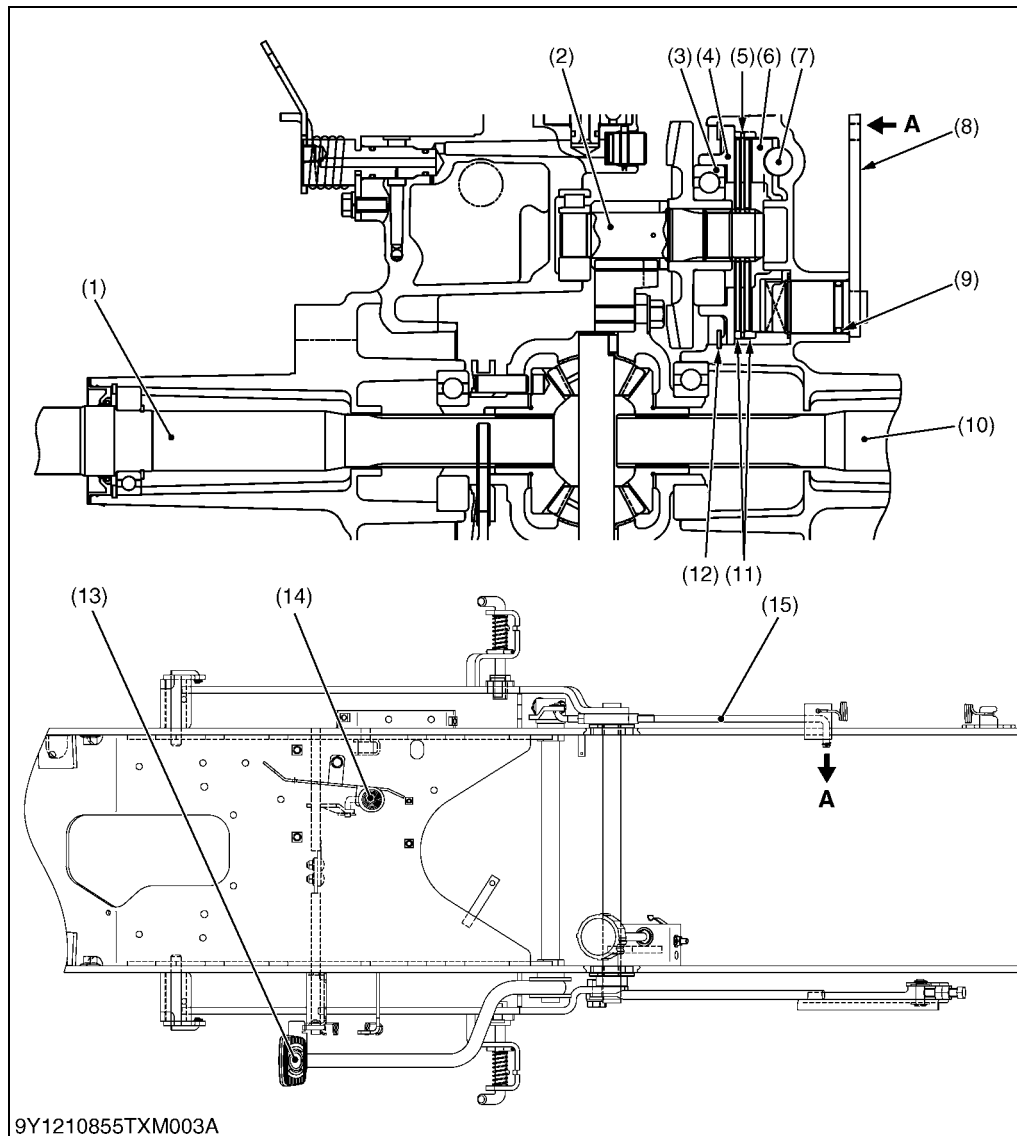

- (1) Rear Axle LH
- (2) Final Gear Shaft
- (3) Shim
- (4) Bearing Holder
- (5) Friction Plate
- (6) Actuator
- (7) Steel Ball
- (8) Cam Lever
- (9) O-ring
- (10) Rear Axle RH
- (11) Brake Disc
- (12) Internal Circlip
- (13) Brake Pedal
- (14) Parking Brake Lock Pedal
- (15) Brake Rod

**A: Connects with Brake Cam Lever and Brake Rod**

9Y1210855TXM003A

The mechanical wet disc brakes are used for the travelling brake. The brake is operated by the brake pedal (13) through the mechanical linkages and provide stable braking and require little adjustment.

The brake body is incorporated in the transmission case and axle cover filled with transmission oil.

For greater braking force, four brake discs (11) are provided at the brake shaft, and the friction plates (5) fixed to the transmission case is arranged between the brake discs (11).

### ■ Travelling Brake

When the brake pedal (13) is depressed, the brake rod (15) pulls the brake cam lever (8).

Therefore, the cam plates also moves and rides on the steel balls set in the grooves of the transmission case to press the brake disc, the final gear shaft is braked by the frictional force generated by the cam plate and brake disc.

### ■ Parking Brake

When the parking brake is applied, the brake pedal (13) is locked by the parking brake lock pedal (14).

9Y1210855TXM0015US0

### 3. PTO SYSTEM

#### [1] PTO CLUTCH AND VALVE

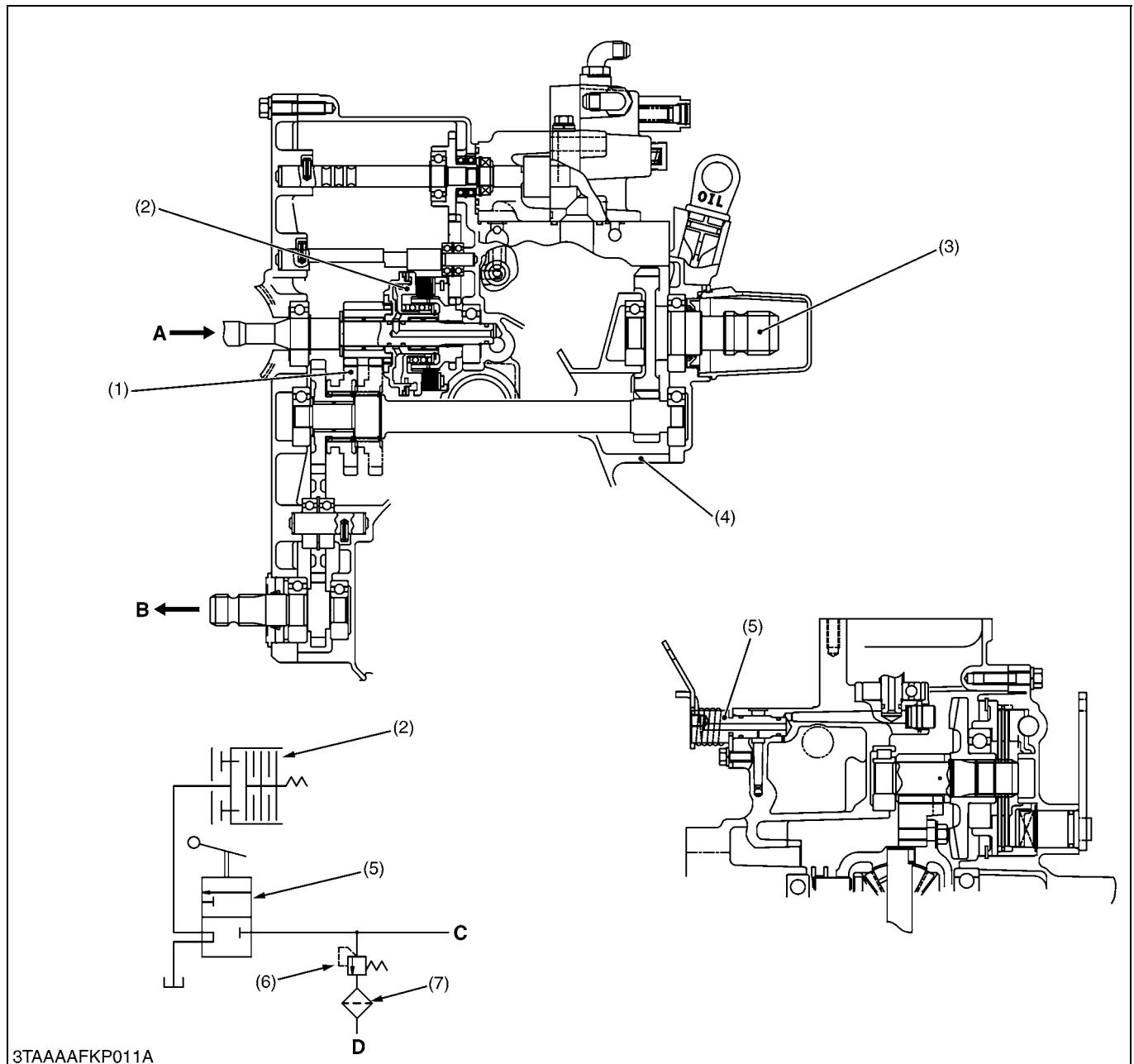

- (1) PTO Select Gear
- (2) PTO Clutch Pack
- (3) Rear PTO Shaft
- (4) Transmission Case

- (5) PTO Clutch Valve
- (6) PTO Clutch Relief Valve
- (7) Oil Filter Cartridge

- A: From HST Pump Shaft**
- B: To Mid-PTO**

- C: From Power Steering Controller**
- D: To Hydrostatic Transmission**

The BX 70 series equipped with hydraulic independent PTO clutch (wet multi-plates type). Therefore, the engine power engages or disengages to the PTO shafts without stopping the tractor movement.

The PTO clutch pack (2) has four clutch discs, four drive plates, pressure plate, clutch piston and so on.

The clutch piston is actuated by hydraulic oil flow from the power steering controller.

The PTO clutch valve (5) controls the hydraulic oil flow from power steering controller to the PTO clutch pack (2) by operating the PTO clutch lever through the linkage.

9Y1210855TXM0016US0

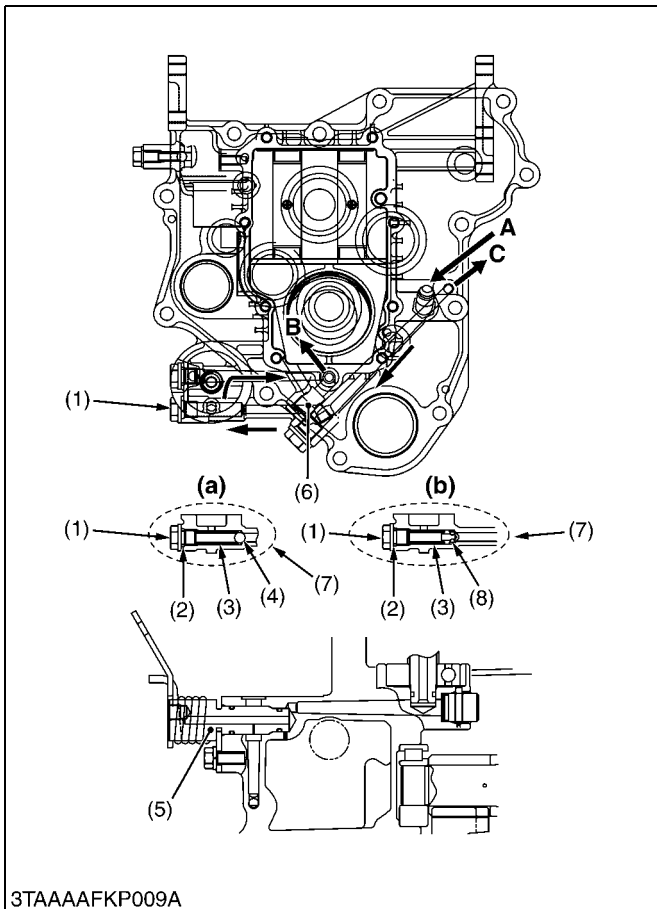

3TAAAFKP009A

### PTO Clutch Relief Valve

The PTO clutch relief valve is provided to control the PTO operating pressure. When the oil pressure exceed the relief valve setting pressure, relief valve opens and the oil flows into PTO clutch and hydrostatic transmission.

#### (Reference)

- Relief valve setting pressure:  
 490 kPa  
 5.0 kgf/cm<sup>2</sup>  
 71.2 psi

- |                             |  |
|-----------------------------|--|
| (1) Plug                    | <b>A: From Power Steering Controller</b> |
| (2) O-ring                  | <b>B: To Hydrostatic Transmission</b>    |
| (3) Spring                  | <b>C: To PTO Clutch Valve</b>            |
| (4) Steel Ball              | <b>(a) Old Type</b>                      |
| (5) PTO Clutch Valve        | <b>(b) New Type</b>                      |
| (6) HST Charge Relief Valve |  |
| (7) PTO Clutch Relief Valve |  |
| (8) Poppet                  |  |

9Y1210855TXM0017US0

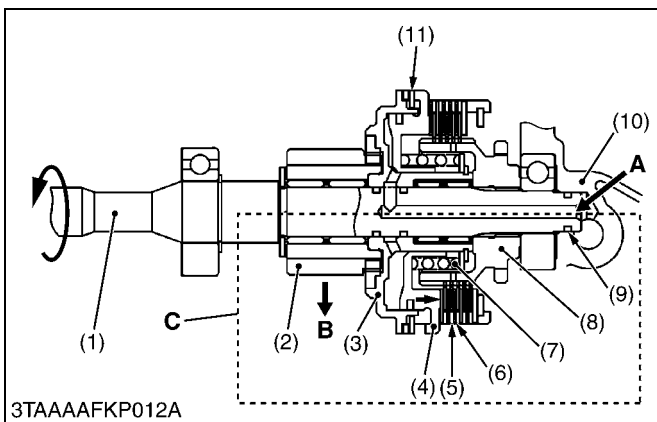

3TAAAFKP012A

### PTO Clutch "Engaged"

The oil from power steering controller flows into the PTO clutch valve.

When the PTO clutch lever is set at the "Engaged" position, the PTO clutch valve rotates. Oil flows from the oil line through transmission case to the PTO clutch pack.

Oil entering the clutch pack pushes the clutch piston (4) to engage the clutch pack. Power is transmitted from the HST pump shaft (1) through the PTO clutch to the clutch gear (2) and the PTO shafts.

- |                    |                                 |
|--------------------|---------------------------------|
| (1) HST Pump Shaft | (9) O-ring                      |
| (2) Clutch Gear    | (10) Transaxle Case             |
| (3) Clutch Case    | (11) Brake Disc                 |
| (4) Clutch Piston  | <b>A: From PTO Clutch Valve</b> |
| (5) Clutch Plate   | <b>B: Power to PTO Shaft</b>    |
| (6) Clutch Disc    | <b>C: PTO Clutch "Engaged"</b>  |
| (7) Spring         |                                 |
| (8) Spline Boss    |                                 |

9Y1210855TXM0018US0

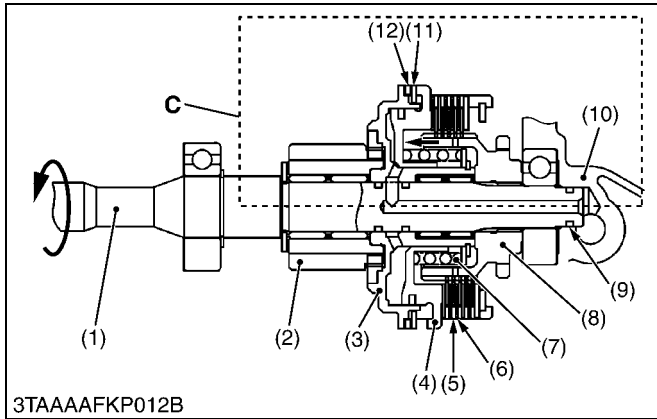

**PTO Clutch "Disengaged"**

When the PTO clutch lever is set at the "Disengaged" position, the PTO clutch valve closes the oil passage to the PTO clutch pack. The oil in the PTO clutch pack drain into the transaxle case (10). Thus the clutch piston (4) is pushed back by the spring (7).

When the clutch piston (4) is pushed back by the spring (7), the brake plate (11) is also moved to contract the brake disc (12) so as to stop the rotation and drag of the PTO shafts.

- |                    |                     |
|--------------------|---------------------|
| (1) HST Pump Shaft | (8) Spline Boss     |
| (2) Clutch Gear    | (9) O-ring          |
| (3) Clutch Case    | (10) Transaxle Case |
| (4) Clutch Piston  | (11) Brake Plate    |
| (5) Clutch Plate   | (12) Brake Disc     |
| (6) Clutch Disc    |                     |
| (7) Spring         |                     |

**C: PTO Clutch "Disengaged"**  
 9Y1210855TXM0019US0



## [2] MID AND REAR PTO SECTION

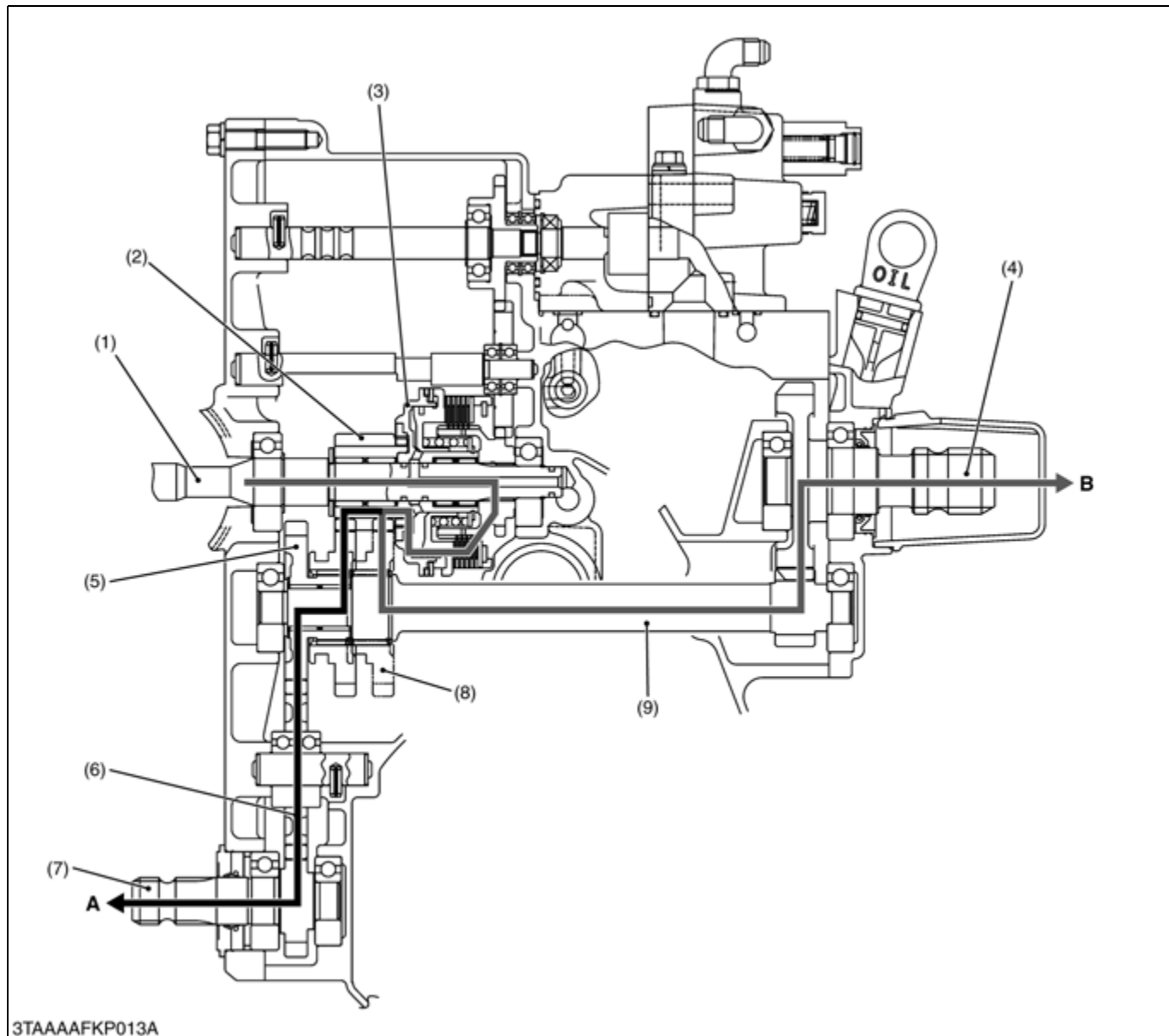

3TAAAFKP013A

- |                     |                      |                           |                         |
|---------------------|----------------------|---------------------------|-------------------------|
| (1) HST Pump Shaft  | (4) Rear PTO Shaft   | (6) 24T Mid PTO Idle Gear | (8) 28T PTO Select Gear |
| (2) 12T Clutch Gear | (5) 23T Mid PTO Gear | (7) Mid-PTO Shaft         | (9) 11T Gear Shaft      |
| (3) PTO Clutch Pack |                      |                           |                         |

Three kinds of power flow are selected by operating the PTO select lever to shift the 28T PTO select gear (8) on the 11T gear shaft (9).

### ■ Mid-PTO Position "A"

PTO Clutch Pack (3) → 12T Gear Clutch (2) → 28T PTO Select Gear (8) → 23T Mid PTO Gear (5) → 24T Mid PTO Idle Gear (6) → Mid-PTO Shaft (7).

### ■ Rear PTO Position "B"

PTO Clutch Pack (3) → 12T Gear Clutch (2) → 28T PTO Select Gear (8) → 11T Gear Shaft (9) → Rear PTO Shaft (4).

### ■ Mid and Rear PTO Position

"A" and "B" at the same time.

9Y1210855TXM0020US0

# 4. OTHERS

## [1] HYDRAULIC PUMP DRIVE GEAR SECTION

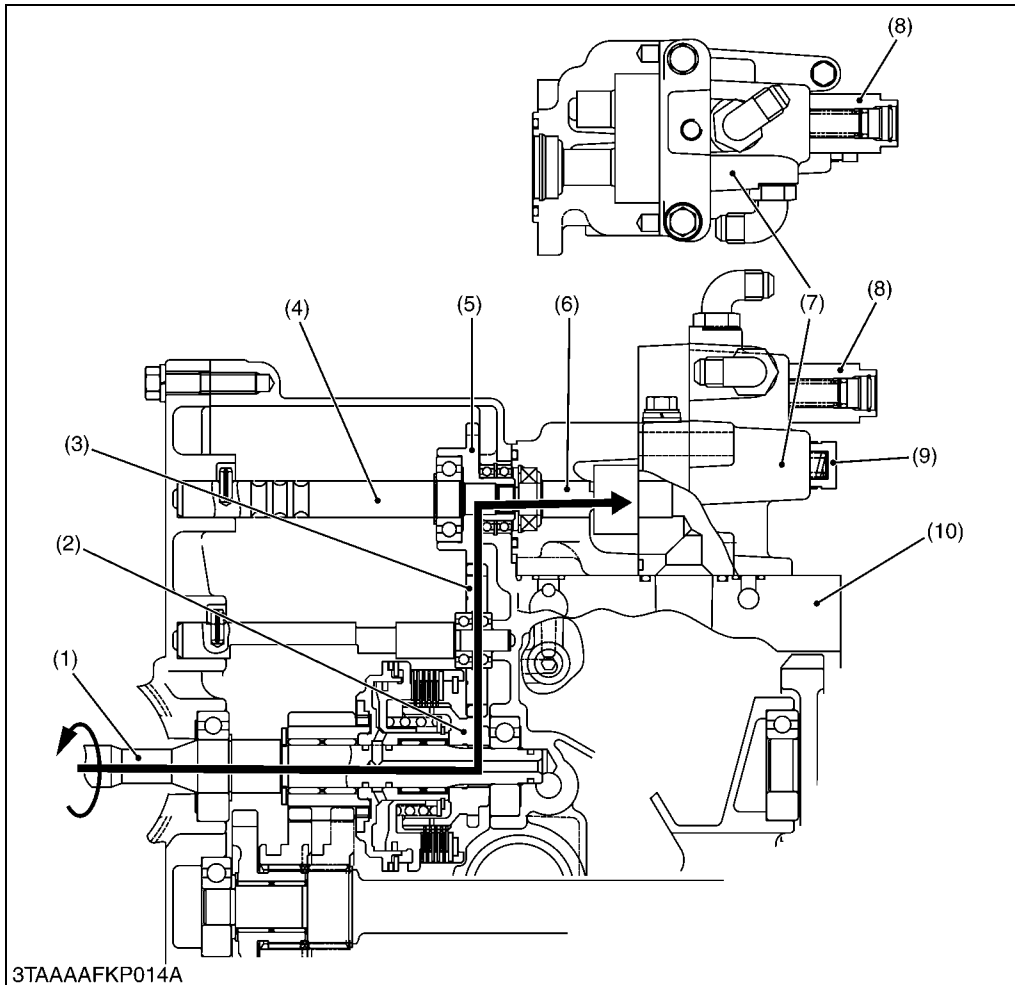

- (1) HST Pump Shaft
- (2) Spline Boss
- (3) Idle Gear
- (4) Hydraulic Pump Drive Gear Shaft
- (5) Hydraulic Pump Drive Gear
- (6) Hydraulic Pump Drive Gear Shaft
- (7) Hydraulic Pump
- (8) Flow Priority Valve
- (9) Relief Valve (3P Hitch)
- (10) Transmission Case

The hydraulic pump (7) is mounted to the transmission case (10) and driven by the hydraulic pump drive gear (5). The spline boss (2) mounted on the HST pump shaft drives the hydraulic pump drive gear (5) mounted on the hydraulic pump drive gear shaft (4) through the idle gear (3).

9Y1210855TXM0021US0

# SERVICING

## CONTENTS

1. TROUBLESHOOTING.....	2-S1
2. SERVICING SPECIFICATIONS.....	2-S5
3. TIGHTENING TORQUES.....	2-S7
4. CHECKING, DISASSEMBLING AND SERVICING.....	2-S8
[1] CHECKING AND ADJUSTING.....	2-S8
[2] PREPARATION.....	2-S16
(1) Separating Transaxle.....	2-S16
[3] DISASSEMBLING AND ASSEMBLING.....	2-S23
(1) Hydrostatic Transmission.....	2-S23
(2) Hydraulic Cylinder.....	2-S29
(3) Transaxle Shafts.....	2-S30
(4) Assembling Shafts.....	2-S38
[4] SERVICING.....	2-S40
(1) Hydrostatic Transmission.....	2-S40
(2) Transaxle Case.....	2-S42

# 1. TROUBLESHOOTING

## HYDROSTATIC TRANSMISSION

Symptom	Probable Cause	Solution	Reference Page
<b>System Will Not Operate in Either Direction</b>	Oil level is low	Check oil level or fill oil to proper level	G-32
	Speed control pedal linkage damaged	Repair linkage	2-S22
	Charge pressure is too low	Solution order 1. Replace oil filter cartridge	G-22
		2. Check charge pressure	2-S12
		3. Inspect or flush charge relief valve	2-S40
	Check and high pressure relief valve does not move smoothly	Inspect or replace check and high pressure relief valve	2-S40
Component parts damaged	Replace hydrostatic transmission assembly	2-S23	
<b>Vibration and Noise</b>	Oil level is low	Check oil level or fill oil to proper level	G-32
	Speed control pedal linkage damaged	Repair linkage	2-S22
	Charge pressure is too low	Solution order 1. Replace oil filter cartridge	G-22
		2. Check charge pressure	2-S12
		3. Inspect or flush charge relief valve	2-S40
	Check and high pressure relief valve does not move smoothly	Inspect or replace check and high pressure relief valve	2-S40
Component parts damaged	Replace hydrostatic transmission assembly	2-S23	
<b>Loss of Power</b>	Oil level is low	Check oil level or fill oil to proper level	G-32
	Speed control pedal linkage damaged	Repair linkage	2-S22
	Charge pressure is too low	1. Replace oil filter cartridge	G-22
		2. Check charge pressure	2-S12
		3. Inspect or flush charge relief valve	2-S40
	Check and high pressure relief valve does not move smoothly	Inspect or replace check and high pressure relief valve	2-S40
Component parts damaged	Replace hydrostatic transmission assembly	2-S23	

Symptom	Probable Cause	Solution	Reference Page
<b>Transmission Oil Over Heats</b>	Low transmission oil level	Fill transmission oil level up to proper level	G-32
	Radiator net clogged	Clean radiator net	–
	Excessive machine load	Reduce machine load	–
	Improper charge pressure	1. Check high relief pressure	2-S12
		2. Replace transmission oil filter cartridge	2-S22
		3. Replace check and high pressure relief valve	2-S40
		4. Inspect and replace charge relief valve	2-S12, 2-S40
<b>Machine Will Not Stop in Neutral Position</b>	Speed control linkage is out of adjustment or sticking	Repair or replace linkage	2-S22
		Adjust neutral position	2-S10
<b>System Operates in One Direction Only</b>	Speed control linkage damaged	Repair or replace linkage	2-S22
	Check and high pressure relief valve damaged	Replace check and high pressure relief valve	2-S40

**TRAVELLING GEAR SHIFT SECTION**

Symptom	Probable Cause	Solution	Reference Page
<b>Noise from Transmission</b>	Transmission oil insufficient	Refill	2-S16
	Gear worn or broken	Replace	–
	Bearings worn	Replace	–
<b>Gear Slip Out of Mesh</b>	Shift fork spring tension insufficient	Replace	2-S38
	Shift fork or shifter worn	Replace	2-S38
	Shift fork bent	Replace	2-S38

**DIFFERENTIAL GEAR SECTION**

Symptom	Probable Cause	Solution	Reference Page
<b>Excessive or Unusual Noise at All Time</b>	Improper backlash between spiral bevel pinion and bevel gear	Adjust	2-S44
	Improper backlash between differential pinion and differential side gear	Adjust	2-S44
	Bearing worn	Replace	–
	Insufficient or improper type of transmission fluid used	Fill or change	G-9, 2-S16
<b>Noise while Turning</b>	Differential pinions or differential side gears worn or damaged	Replace	2-S35
	Differential lock binding (does not disengaged)	Replace	2-S35
	Bearing worn	Replace	–
<b>Differential Lock Can Not Be Set</b>	Differential lock shift fork damaged	Replace	2-S35
	Differential lock shifter mounting pin damaged	Replace	2-S35
	Differential lock pin damaged	Replace	2-S35
<b>Differential Lock Pedal Does Not Return</b>	Differential lock pedal return spring weaken or damaged	Replace	2-S22
	Differential lock fork shaft rusted	Repair	2-S35

**BRAKE SECTION**

Symptom	Probable Cause	Solution	Reference Page
<b>Brake Drags</b>	Brake pedal free travel too small	Adjust	G-30
	Ball holes of actuator for uneven wear	Replace	2-S46
	Brake pedal return spring weaken or broken	Replace	2-S21
	Brake cam rusted	Repair	2-S36
<b>Poor Braking Force</b>	Brake pedal free travel excessive	Adjust	G-30
	Brake disc worn	Replace	2-S36
	Actuator warped	Replace	2-S36
	Brake cam or lever damaged	Replace	2-S36
	Transmission fluid improper	Change	2-S16

**PTO SECTION**

<b>Symptom</b>	<b>Probable Cause</b>	<b>Solution</b>	<b>Reference Page</b>
<b>PTO Clutch Slip</b>	Operating pressure is low	Check	2-S15
	PTO clutch valve malfunctioning	Repair or replace	2-S23
	Clutch disc or drive plate excessively worn	Replace	2-S37
	Deformation of clutch piston	Replace	2-S37
<b>PTO Shaft Does Not Rotate</b>	PTO clutch malfunctioning	Repair or replace	2-S37
<b>PTO Clutch Operating Pressure is Low</b>	Transmission oil improper or insufficient	Fill or change	2-S16
	Relief valve malfunctioning	Check or replace	2-M16
<b>PTO Clutch Drags</b>	Brake plate excessive worn	Replace	2-S37
	Clutch spring weaken or broken	Replace	2-S37
	Deformation of pressure plate or steel plate	Replace	2-S37

9Y1210855TXS0001US0

## 2. SERVICING SPECIFICATIONS

Item		Factory Specification	Allowable Limit
Charge Relief Valve [Oil temperature at 50 °C (122 °F)]	Setting Pressure	0.55 to 0.75 MPa 5.6 to 7.7 kgf/cm <sup>2</sup> 80 to 100 psi	–
High Pressure Relief Valve (Forward and Reverse) [Oil temperature at 50 °C (122 °F)]	Setting Pressure	20.1 to 21.1 MPa 205 to 215 kgf/cm <sup>2</sup> 2920 to 3060 psi	–
PTO Clutch	Operating Pressure	1.0 to 1.3 MPa 11 to 13 kgf/cm <sup>2</sup> 150 to 180 psi	–
PTO Clutch Disc	Thickness	1.50 to 1.70 mm 0.0591 to 0.0669 in.	1.35 mm 0.0531 in.
Separate Plate	Thickness	0.9450 to 1.055 mm 0.03721 to 0.04153 in.	0.80 mm 0.031 in.
Back Plate	Thickness	1.9 to 2.1 mm 0.075 to 0.082 in.	1.85 mm 0.0728 in.
Clutch Piston	Flatness	–	0.15 mm 0.0059 in.
Pressure Plate and Steel Plate	Flatness	–	0.20 mm 0.0079 in.
Clutch Spring	Free Length	38.5 mm 1.52 in.	34.5 mm 1.36 in.
PTO Brake Disc	Thickness	2.90 to 3.10 mm 0.115 to 0.122 in.	2.70 mm 0.11 in.
PTO Brake Plate	Thickness	1.9 to 2.1 mm 0.075 to 0.082 in.	1.85 mm 0.0728 in.
Differential Case to Differential Side Gear	Clearance	0.0500 to 0.151 mm 0.00197 to 0.00594 in.	0.30 mm 0.012 in.
• Differential Case	I.D.	38.000 to 38.062 mm 1.4961 to 1.4985 in.	–
• Differential Side Gear	O.D.	37.911 to 37.950 mm 1.4926 to 1.4940 in.	–
Differential Pinion Shaft to Differential Pinion	Clearance	0.0800 to 0.122 mm 0.00315 to 0.00480 in.	0.30 mm 0.012 in.
• Differential Pinion	I.D.	20.060 to 20.081 mm 0.78977 to 0.79059 in.	–
• Differential Pinion Shaft	O.D.	19.959 to 19.980 mm 0.78579 to 0.78661 in.	–
Differential Pinion to Differential Side Gear	Backlash	0.15 to 0.30 mm 0.0059 to 0.011 in.	0.40 mm 0.016 in.
Spiral Bevel Pinion Shaft to Spiral Bevel Gear	Backlash	0.10 to 0.30 mm 0.0040 to 0.011 in.	–
Actuator and Bearing Holder	Flatness	–	0.30 mm 0.012 in.
Cam Plate and Ball	Height	22.89 to 22.99 mm 0.9012 to 0.9051 in.	22.40 mm 0.8819 in.



Item		Factory Specification	Allowable Limit
Brake Disc	Thickness	3.30 to 3.50 mm 0.130 to 0.137 in.	3.0 mm 0.12 in.
Friction Plate	Thickness	1.92 to 2.08 mm 0.0756 to 0.0818 in.	1.52 mm 0.0598 in.

9Y1210855TXS0002US0

### 3. TIGHTENING TORQUES

Tightening torques of screws, bolts and nuts on the table below are especially specified.  
 (For general use screws, bolts and nuts: Refer to "5. TIGHTENING TORQUES" on page G-13.)

Item	N·m	kgf·m	lbf·ft
Charge relief valve checking plug (R 1/4)	30 to 44	3.0 to 4.5	22 to 32
Hexagon socket head plug (R 1/4)	30 to 44	3.0 to 4.5	22 to 32
Hexagon socket head screw	25 to 29	2.5 to 3.0	18 to 21
PTO clutch operating pressure plug (R 1/8)	13 to 21	1.3 to 2.2	9.4 to 15
ROPS mounting nut	124 to 147	12.6 to 15.0	91.2 to 108
Fuel tank stay mounting bolt and nut	48 to 55	4.9 to 5.7	36 to 41
Fender bracket mounting bolt and nut	124 to 147	12.6 to 15.0	91.2 to 108
Rear wheel mounting screw	109 to 129	11.1 to 13.2	80.3 to 95.4
Hitch plate mounting bolt and nut	124 to 147	12.6 to 15.0	91.2 to 108
Transaxle assembly mounting screw (M12)	63 to 72	6.4 to 7.4	47 to 53
Transaxle assembly mounting screw (M14)	124 to 147	12.6 to 15.0	91.2 to 108
Rear coupling mounting screw (M8)	24 to 27	2.4 to 2.8	18 to 20
Front coupling mounting screw (M8)	24 to 27	2.4 to 2.8	18 to 20
HST fan mounting screw (M8)	9.8 to 11	1.0 to 1.2	7.3 to 8.6
Hydraulic control lever mounting bolt and nut	18 to 20	1.8 to 2.1	13 to 15
HST front cover mounting bolt and nut	18 to 20	1.8 to 2.1	13 to 15
Check and high pressure relief valve plug	59 to 78	6.0 to 8.0	44 to 57
Hydraulic cylinder mounting screw	40 to 44	4.0 to 4.5	29 to 32
Transaxle case front cover mounting bolt (M10)	39 to 44	4.0 to 4.4	29 to 32
Hydraulic pump assembly mounting bolt (M6)	7.9 to 8.8	0.80 to 0.90	5.8 to 6.5
Hydraulic pump assembly mounting bolt (M8)	18 to 20	1.8 to 2.1	13 to 15
Rear PTO cover mounting bolt (M8)	18 to 20	1.8 to 2.1	13 to 15
Rear axle case (RH) mounting bolt (M8)	18 to 20	1.8 to 2.1	13 to 15
66T final gear mounting screw	61 to 70	6.2 to 7.2	45 to 52

9Y1210855TXS0003US0

# 4. CHECKING, DISASSEMBLING AND SERVICING

## [1] CHECKING AND ADJUSTING

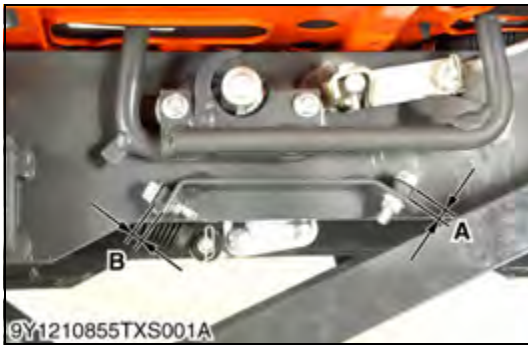

### Adjusting Maximum Speed

1. Lift up the rear wheels safely by the rigid jacks.
2. Shift the front wheel drive lever to "OFF" position.
3. Depress the speed control pedal to the forward all the way and lengthen the stopper bolt (for the forward) until it touches the speed control pedal.
4. Adjust the stopper bolt (for the forward) length "A" to 17.0 mm (0.669 in.) and lock it securely.
5. Adjust the stopper bolt (for the reverse) length "B" to 17.5 mm (0.689 in.) and lock it securely.
6. Finally check the travelling speed or rear axle shaft rotation speed.
7. If the measurement is not within the references, check the adjusting bolt length "A", "B".

### ■ IMPORTANT

- Speed control pedal should contact with adjusting bolt "A" and/or "B", when depress the speed control pedal fully.

Stopper bolt length	Reference	Forward	17.0 mm 0.669 in.
		Reverse	17.5 mm 0.689 in.

Maximum rear axle shaft speed (at engine maximum speed and low range)	Reference	52.2 min <sup>-1</sup> 52.2 rpm
--	-----------	------------------------------------

Maximum travelling speed (at engine maximum speed)	Reference [BX1870D]	Forward	12.0 to 13.0 km/h 7.46 to 8.07 mph
		Reverse	9.00 to 10.0 km/h 5.60 to 6.21 mph
	Reference [BX2370D and BX2670D]	Forward	13.0 to 14.0 km/h 8.08 to 8.69 mph
		Reverse	10.0 to 11.0 km/h 6.22 to 6.83 mph

**A: Stopper Bolt Length (Forward)    B: Stopper Bolt Length (Reverse)**

9Y1210855TXS0004US0

**Preparation before HST Adjustment**

**⚠ CAUTION**

- **Park the machine on a firm and level ground.**
- 1. Place the wooden blocks at the front and the rear side of the wheels not to move the tractor.
- 2. Lift up the rear wheels (1) safely by the rigid jacks.
- 3. Shift the front wheel drive lever (2) to "OFF" position (A).
- 4. Remove the rear right wheel from the tractor.

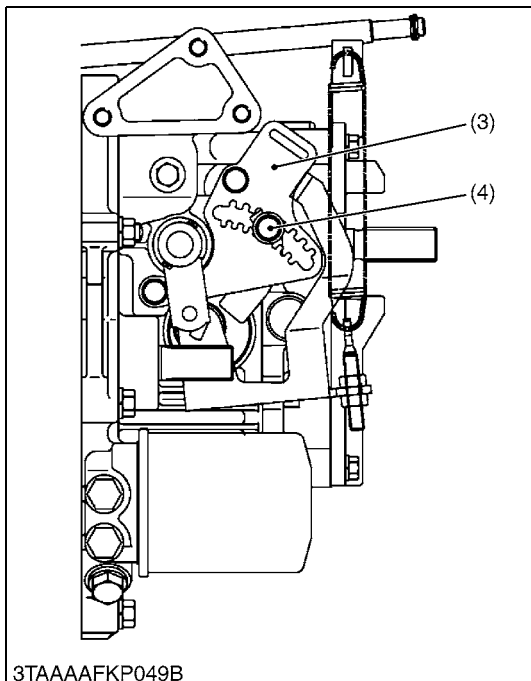
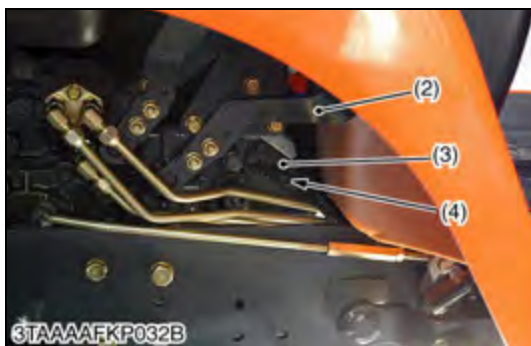
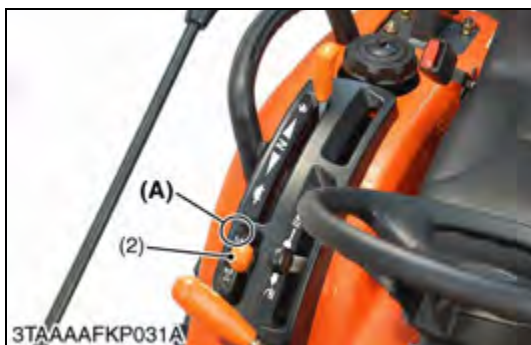

- (1) Rear Wheel
  - (2) Front Wheel Drive Lever
  - (3) Neutral Adjuster
  - (4) Lock Screw
- (A) "OFF" Position

9Y1210855TXS0005US0

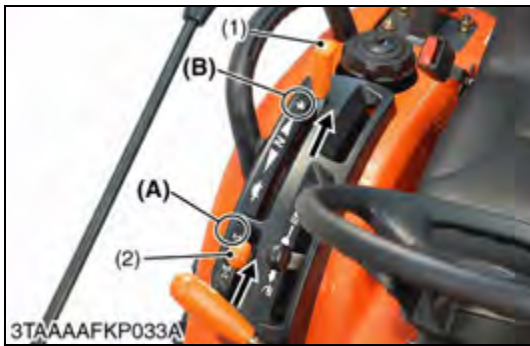

### Adjustment of HST Neutral Position

1. Start the engine.
2. Keep the engine at the maximum revolution.
3. Shift the range shift lever (1) to "Hi" position (B).
4. Loosen the locking screw (5).

#### NOTE

- When adjusting the HST neutral position, loosen the locking screw approximately 2 turns counterclockwise not to drop the nut inside.
- Make sure 4WD lever is set to 2WD before making adjustment.

#### (Forward to Neutral Position)

5. Depress the speed control pedal (3) to "Forward" speed position, and release the foot from the speed control pedal (3). Check that the rear axle (or the wheel) stops rotating. If the rear axle (or the wheel) does not stop rotating, move the position of the locking screw (5) to the machine front side to stop rotating.

#### (Reverse to Neutral Position)

6. Depress the speed control pedal (3) to "Reverse" speed position, and release the foot from the speed control pedal (3). Check the rear axle (or the wheel) stops rotating. If the rear axle (or the wheel) does not stop rotating, adjust the locking screw (5) to stop rotating.
7. After adjusting the neutral position, tighten the lock screw (5) securely.

- |                             |                        |
|-----------------------------|------------------------|
| (1) Range Gear Shift Lever  | (A) 4WD "OFF" Position |
| (2) Front Wheel Drive Lever | (B) "Hi" Position      |
| (3) Speed Control Pedal     | (C) FORWARD            |
| (4) Neutral Adjust Lever    | (D) REVERSE            |
| (5) Locking Screw           |                        |
| (6) Screw Driver            |                        |

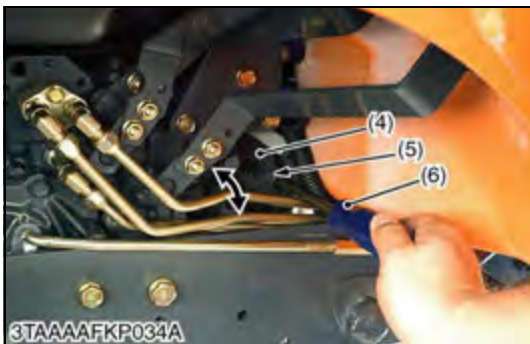

9Y1210855TXS0006US0



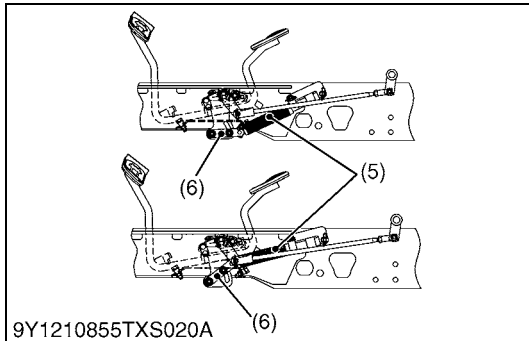
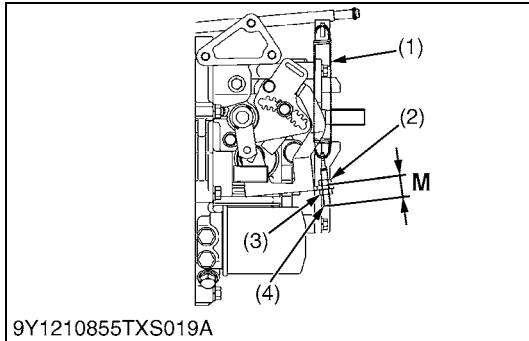
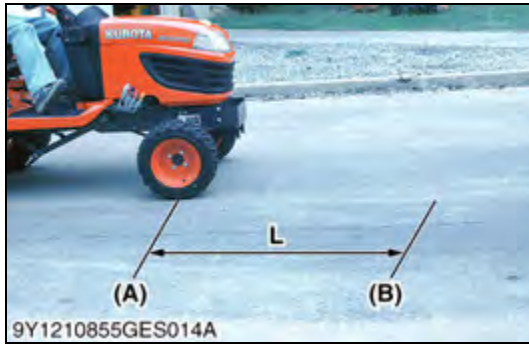

### Checking and Adjusting HST Neutral Spring (for Dynamic Braking)

#### ⚠ WARNING

- Do not operate if tractor move on level ground with foot off speed control pedal.
- If tractor moves on level ground with foot off the pedal, or, if the pedal is too slow in returning to "Neutral" position when removing the foot from the pedal, adjust the HST neutral spring.

The HST neutral spring located under the front right side of the fender can adjust returning speed of speed control pedal.

Since the HST neutral spring tension is weakened, the HST tension should be checked and adjusted every 100 hours.

1. Checking the HST neutral spring tension: Dynamic braking
  - Start the engine and hold the maximum engine speeds.
  - Operate the machine on the concrete level ground.
  - Shift the range gear shift lever to "Hi" position.
  - Depress the speed control pedal to "Forward".
  - Release the foot from the speed control pedal.
  - Check the distance between the foot releasing point and the machine stopping point.
  - If the distance is more than approximately 3 m (10 feet), strengthen the HST neutral spring tension so that the machine will stop in approximately 3 m (10 feet) after releasing the foot from the speed control pedal.

#### (Reference)

Distance "L" between the foot releasing point and the machine stopping point	Reference	Approximately 3 m (10 feet)
--	-----------	-----------------------------

2. Remove the step from the machine.
  - Loosen the lock nut (2).
  - Turn the adjusting nut (3) half turn to pull the HST neutral spring (1).
  - Tighten and lock the lock nut (2).
  - Start the engine and check dynamic brake as mentioned former.
  - If the machine will not stop with dynamic brake in approximately 3 m (10 feet), adjust the neutral spring again.

#### (Reference)

- The feeling of dynamic braking can be adjusted by changing the arm (6) position of damper (5).

Length "M" of adjusting rod at shipping the machine from the factory	Reference	10 mm 0.39 in.
--	-----------	----------------

- |                        |   |
|------------------------|---|
| (1) HST Neutral Spring | (A) Foot Releasing Point  |
| (2) Lock Nut           | (B) Machine Stopping Point  |
| (3) Adjusting Nut      | L: Distance between Foot Releasing Point and the Machine Stopping Point |
| (4) Adjusting Rod      | M: Length of Adjusting Rod from Stay                                    |
| (5) Damper             |   |
| (6) Arm                |   |

9Y1210855TXS0007US0



**Charge Relief Pressure**

**CAUTION**

- When checking, park the tractor on flat ground, and apply the parking brake.
1. Remove the plug (R 1/4) (1) from the front cover, then install the adaptor (R 1/4) and pressure gauge.
  2. Set the range gear shift lever to "Neutral" position.
  3. Start the engine and run it at the maximum speed.
  4. Read the pressure gauge to measure the charge relief pressure.
  5. If the measurement is not within the factory specifications, check the charge relief valve and related hydraulic components.

**NOTE**

- When reinstalling the hexagon socket head plug, apply liquid lock (Three Bond 1324 or its equivalent) to the plug.

Charge relief pressure (Oil temperature at 50 °C, 122 °F)	Factory specification	0.55 to 0.75 MPa 5.6 to 7.7 kgf/cm <sup>2</sup> 80 to 100 psi
--	-----------------------	---

Tightening torque	Charge relief valve checking plug (R 1/4)	30 to 44 N·m 3.0 to 4.5 kgf·m 22 to 32 lbf·ft
-------------------	---	---

(1) Plug

9Y1210855TXS0008US0



**High Relief Pressure (Forward)**

**CAUTION**

- When checking, park the tractor on flat ground, and apply the parking brake.
1. Remove the hexagon socket head plug (R 1/4) from P2 (2), then install the adaptor, cable and pressure gauge.
  2. Start the engine and run it at maximum speed.
  3. Set the range gear shift lever to "Hi" position.
  4. Depress the speed control pedal to "Forward", and read the pressure gauge to measure the high relief pressure.
  5. If the measurement is not same as factory specification, check the high pressure relief valve and related hydraulic components.

High relief pressure (Forward) (Oil temperature at 50 °C, 122 °F)	Factory specification	20.1 to 21.1 MPa 205 to 215 kgf/cm <sup>2</sup> 2920 to 3060 psi
---	-----------------------	--

Tightening torque	Hexagon socket head plug (P1 and P2 port)	30 to 44 N·m 3.0 to 4.5 kgf·m 22 to 32 lbf·ft
-------------------	---	---

**IMPORTANT**

- Measure quickly the high relief pressure within about 10 seconds.

**NOTE**

- When reinstalling the hexagon socket head plug, apply liquid lock (Three Bond 1324 or its equivalent) to the plug.

(1) P1 Port (Reverse)

(2) P2 Port (Forward)

9Y1210855TXS0009US0





9Y1210855TXS002A



3TAAAFKP036B



9Y1210855TXS005B

### High Relief Pressure (Reverse)

#### CAUTION

- When checking, park the tractor on flat ground, and apply the parking brake.
1. Remove the hexagon socket head plug (R 1/4) from P1 (1), then install the adaptor, cable and pressure gauge.
  2. Start the engine and run it at maximum speed.
  3. Set the range gear shift lever to "Hi" position.
  4. Depress the speed control pedal to "Reverse", and read the pressure gauge to measure the high relief pressure.
  5. If the measurement is not same as factory specification, check the high pressure relief valve and related hydraulic components.

High relief pressure (Reverse) (Oil temperature at 50 °C, 122 °F)	Factory specification	20.1 to 21.1 MPa 205 to 215 kgf/cm <sup>2</sup> 2920 to 3060 psi
--	-----------------------	--

Tightening torque	Hexagon socket head plug (P1 and P2 port)	30 to 44 N·m 3.0 to 4.5 kgf·m 22 to 32 lbf·ft
-------------------	---	---

#### ■ IMPORTANT

- Measure quickly the high relief pressure within about 10 seconds.

#### ■ NOTE

- When reinstalling the hexagon socket head plug, apply liquid lock (Three Bond 1324 or its equivalent) to the plug.

(1) P1 Port (Reverse)

(2) P2 Port (Forward)

9Y1210855TXS0010US0



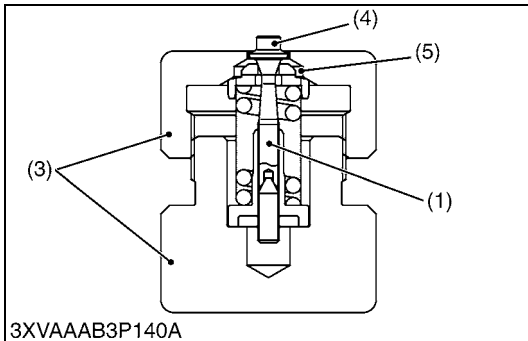
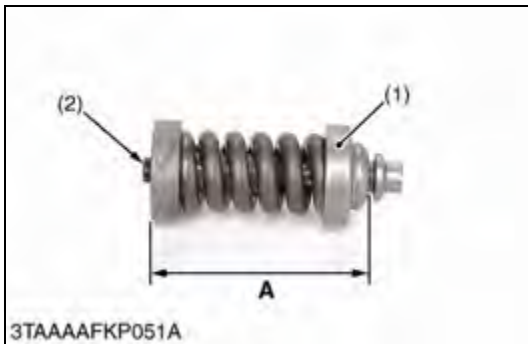

**Readjustment of Relief Valve (When the HST does not Work Due to its Loose Hexagon Socket Head Screw)**

■ **IMPORTANT**

- KUBOTA does not recommend the readjustment of relief valve. KUBOTA recommends with genuine parts.
- As the HST may be damaged if the pressure is set to high by mistake, be careful when adjusting it.

■ **NOTE**

- The relief pressure is set in between 20.1 to 21.1 MPa (205 to 215 kgf/cm<sup>2</sup>, 2920 to 3060 psi) when shipped from the factory. But, for the purpose of after-sales services, as it is impossible to reset the pressure precisely as set in the factory, its setting range is defined as a slightly wider range between 15.0 to 20.0 MPa (153 to 203 kgf/cm<sup>2</sup>, 2180 to 2900 psi).

1. Measure the pre-adjustment distance "A".
2. Compress the spring of the relief valve with a relief valve assembling tool (3).
3. Then, find the distance "A" by turning the poppet (4) with a screwdriver.

Reference: The distance "A" changes by about 0.5 mm (0.02 in.) per one turn of the poppet (4).

4. Repeat the same operation a few times to find the distance "A" as it is difficult to acquire at the first time.
5. After finding the distance "A", hold the setscrew (6) to a vice and fasten the hexagon socket head screw (2) with specified torque. On this occasion, use a copper plate, etc. for the vice jaws not to damage the setscrew (6).
6. Install the relief valve in the HST.
7. Check the relief pressure as indicated in page 2-S12 and 2-S13. The distance "A" is for refresh only. Make sure to check the relief pressure after readjustment.

8. If the relief pressure does not fall within the readjustment pressure range, repeat the processes of the above.

Reference: The pressure changes by 1.5 MPa (15 kgf/cm<sup>2</sup>, 210 psi) per 0.1 mm (0.004 in.) in distance "A".

Tightening torque	Hexagon socket head screw	25 to 29 N·m 2.5 to 3.0 kgf·m 18 to 21 lbf·ft
-------------------	---------------------------	---

Relief valve readjusting pressure	Factory specification	15.0 to 20.0 MPa 153 to 203 kgf/cm <sup>2</sup> 2180 to 2900 psi
-----------------------------------	-----------------------	--

Distance "A" of relief valve (Forward)	Reference value	39.10 to 39.20 mm 1.540 to 1.543 in.
Distance "A" of relief valve (Reverse, φ1.5 mm orifice)	Reference value	38.60 to 38.70 mm 1.520 to 1.523 in.

- (1) Relief Valve Assembly
  - (2) Hexagon Socket Head Screw
  - (3) Relief Valve Assembling Tool
  - (4) Poppet
  - (5) Valve Seat
  - (6) Setscrew
- A: Distance**

9Y1210855TXS0011US0



**PTO Clutch Operating Pressure**

**⚠ CAUTION**

- **When checking, park the tractor on flat ground, apply the parking brake.**
- 1. Lift the rear of the tractor and remove the left rear wheel.
- 2. Remove the plug (R 1/8), then install the adaptor (R 1/8), cable and pressure gauge.
- 3. Start the engine and set at maximum speed.
- 4. Move the PTO clutch lever to "**Engaged**" position, and measure the pressure.
- 5. If the measurement is not same as factory specifications, check the PTO relief valve and related hydraulic components.

**■ IMPORTANT**

- **Do not connect the universal joint of the implement to the mid and rear PTO shaft.**

**■ NOTE**

- **When reinstall the hexagon socket head plug, apply liquid lock (Three Bond 1324 or its equivalent) to the plug.**

PTO clutch operating pressure	Factory specification	1.0 to 1.3 MPa 11 to 13 kgf/cm <sup>2</sup> 150 to 180 psi
-------------------------------	-----------------------	--

Tightening torque	PTO clutch valve plug (R 1/8)	13 to 21 N·m 1.3 to 2.2 kgf·m 9.4 to 15 lbf·ft
-------------------	-------------------------------	--

**Condition**

- Engine speed: Maximum
- Oil temperature: 45 to 55 °C (113 to 131 °F)

9Y1210855TXS0012US0

**Brake Pedal Free Travel**

1. See page G-30.

9Y1210855TXS0013US0

## [2] PREPARATION

### (1) Separating Transaxle

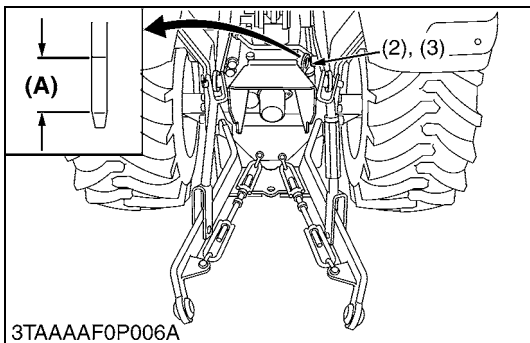
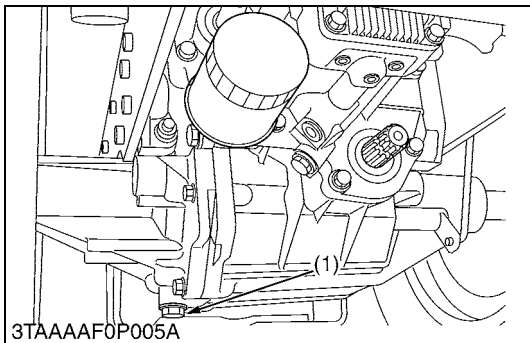

#### Draining Transmission Fluid

##### ⚠ CAUTION

- Be sure to stop the engine before checking and changing the transmission fluid.

1. Place oil pan under the tractor.
2. Remove the drain plug (1) at the bottom of the transmission case.
3. Drain the transmission fluid and reinstall the drain plug.

##### (When refilling)

- Fill new oil from filling port after removing the filling plug (2) up to the upper notch on the dipstick (3).
- After running the engine for few minutes, stop it and check the oil level again, if low, add oil to prescribed level.

##### ■ IMPORTANT

- Do not operate the tractor immediately after changing the transmission fluid.
- Run the engine at medium speed for a few minutes to prevent damage to the transmission.
- Do not mix different brands oil together.

Transmission fluid	Capacity	11.6 L 3.1 U.S.gals 2.6 Imp.gals
--------------------	----------	--

- (1) Drain Plug
- (2) Filling Plug
- (3) Dipstick

(A) Oil level is acceptable within this range.

9Y1210855TXS0014US0

#### Battery

##### ⚠ CAUTION

- When disconnecting the battery cables, disconnect the negative cable from the battery first. When connecting, connect the positive cable to the battery first.

1. Remove the under panel.
2. Disconnect the negative cable (2) from the battery (1).
3. Disconnect the positive cable (3) from the battery (1) and remove the battery (1).

- (1) Battery
- (2) Negative Cable

(3) Positive Cable

9Y1210855TXS0015US0

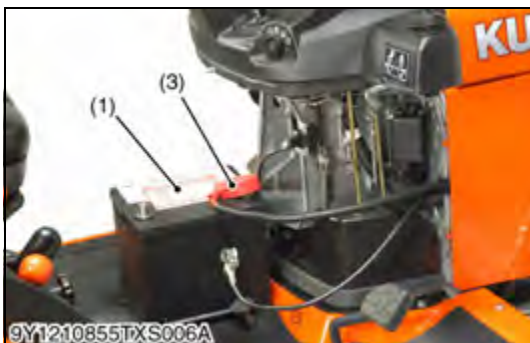

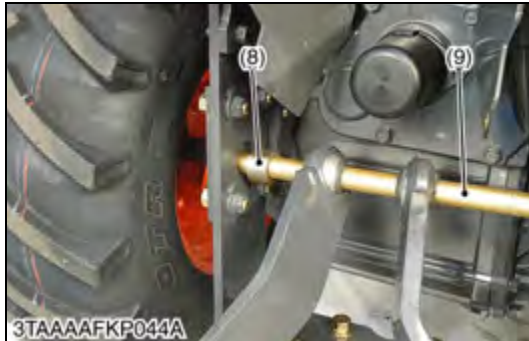
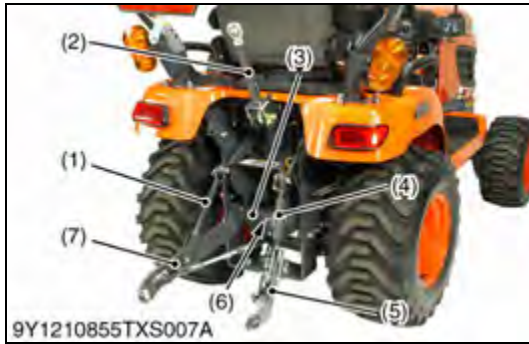

**Lift Rod and Lower Link**

1. Remove the top link (2).
2. Remove the stopper pin (6) and remove the check chain plate (3).
3. Move the bushes (8) to inside.
4. Move the shaft (9) to right side and remove the lower link as a unit.

- |                       |                   |
|-----------------------|-------------------|
| (1) Lift Rod LH       | (6) Stopper Pin   |
| (2) Top Link          | (7) Lower Link LH |
| (3) Check Chain Plate | (8) Bush          |
| (4) Lift Rod RH       | (9) Shaft         |
| (5) Lower Link RH     |                   |

9Y1210855TXS0016US0



**Roll-Over Protective Structures (ROPS)**

1. Disconnect the lead wires from the hazard lamp (2), (4) and turn signal lights (3), (5).
2. Remove the ROPS mounting nuts, and remove the ROPS (1).

**(When reassembling)**

Tightening torque	ROPS mounting nut	124 to 147 N·m 12.6 to 15.0 kgf·m 91.2 to 108 lbf·ft
-------------------	-------------------	--

- |                          |                          |
|--------------------------|--------------------------|
| (1) ROPS                 | (4) Hazard Lamp RH       |
| (2) Hazard Lamp LH       | (5) Turn Signal Light RH |
| (3) Turn Signal Light LH |                          |

9Y1210855TXS0017US0



**Seat**

1. Disconnect the seat switch connectors.
2. Remove the snap pins (2) to remove the seat (1).

- |          |              |
|----------|--------------|
| (1) Seat | (2) Snap Pin |
|----------|--------------|

9Y1210855TXS0018US0



**Speed Control Pedal and Step**

1. Remove the valve covers (3).
2. Remove the speed control pedals (1) and step (2).

- |                         |                 |
|-------------------------|-----------------|
| (1) Speed Control Pedal | (3) Valve Cover |
| (2) Step                |                 |

9Y1210855TXS0019US0



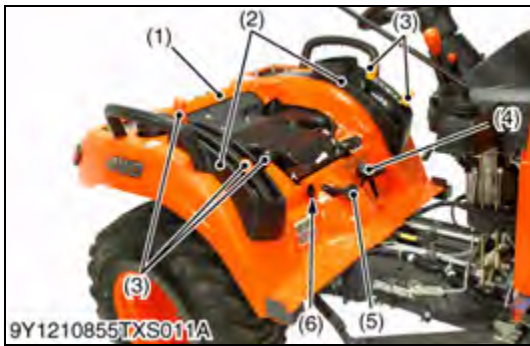

**Lever Grips and Fender**

1. Remove the connector from the electric outlet (6).
2. Remove the lowering speed adjusting knob (5) and cutting height adjusting dial knob (4).
3. Remove the lever grips (3).
4. Remove the fender (1).

- |                 |  |
|-----------------|--|
| (1) Fender      | (4) Cutting Height Adjusting Dial Knob |
| (2) Lever Guide | (5) Lowering Speed Adjusting Knob      |
| (3) Lever Grip  | (6) Electric Outlet                    |

9Y1210855TXS0020US0



**Fuel Tank**

1. Drain the fuel.
2. Disconnect the lead wire from fuel level sensor and fuel hoses from the fuel tank (1).
3. Remove the fuel tank stays (2), (3) and cushions, then remove the fuel tank (1).
4. Remove the PTO cover (4).

**(When reassembling)**

Tightening torque	Fuel tank stay mounting bolt and nut	48 to 55 N·m 4.9 to 5.7 kgf·m 36 to 41 lbf·ft
-------------------	--------------------------------------	---

- |                       |                       |
|-----------------------|-----------------------|
| (1) Fuel Tank         | (3) Fuel Tank Stay RH |
| (2) Fuel Tank Stay LH | (4) PTO Cover         |

9Y1210855TXS0021US0



**Fender Center Stay**

1. Remove the fender bracket (2).
2. Remove the fender center stay (1).

**(When reassembling)**

Tightening torque	Fender bracket mounting bolt	124 to 147 N·m 12.6 to 15.0 kgf·m 91.2 to 108 lbf·ft
-------------------	------------------------------	--

- |                        |                    |
|------------------------|--------------------|
| (1) Fender Center Stay | (2) Fender Bracket |
|------------------------|--------------------|

9Y1210855TXS0022US0

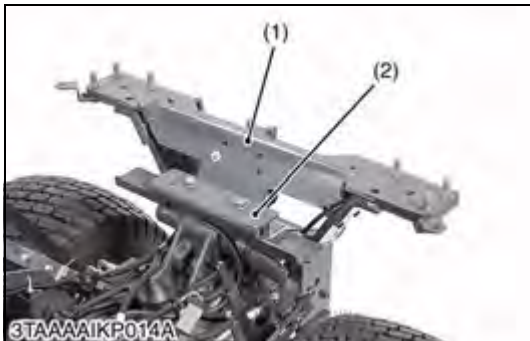

**Rear Wheel**

1. Remove the rear wheels (1) and (2).

**(When reassembling)**

Tightening torque	Rear wheel mounting bolt	109 to 129 N·m 11.1 to 13.2 kgf·m 80.3 to 95.4 lbf·ft
-------------------	--------------------------	---

- |                   |                   |
|-------------------|-------------------|
| (1) Rear Wheel LH | (2) Rear Wheel RH |
|-------------------|-------------------|

9Y1210855TXS0023US0

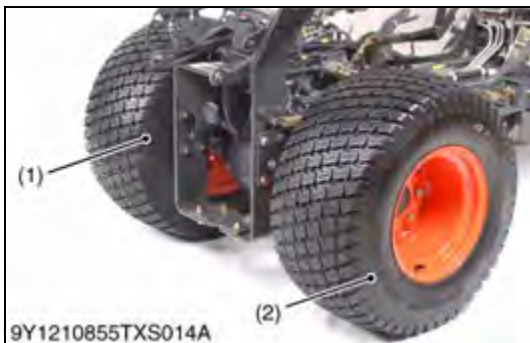

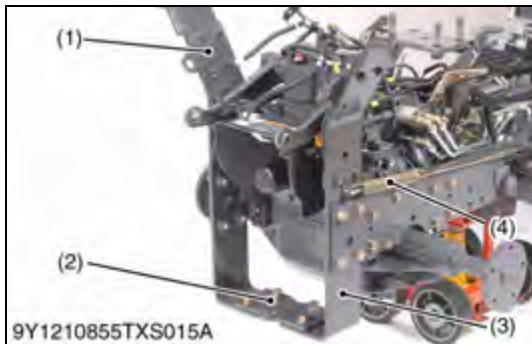

**Fender Bracket, Hitch Plate**

1. Remove the hitch plate (2).
2. Remove the parking brake return spring (4) and the fender brackets (1), (3).

**(When reassembling)**

- Do not firmly tighten all screws, bolts and nuts until most components are attached.

Tightening torque	Hitch plate mounting bolt and nut (M14)	124 to 147 N·m 12.6 to 15.0 kgf·m 91.2 to 108 lbf·ft
	Fender bracket mounting bolt and nut (M14)	124 to 147 N·m 12.6 to 15.0 kgf·m 91.2 to 108 lbf·ft

- (1) Fender Bracket LH  
(2) Hitch Plate

- (3) Fender Bracket RH  
(4) Return Spring

9Y1210855TXS0024US0

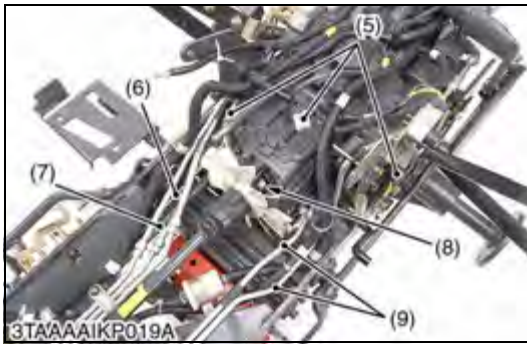
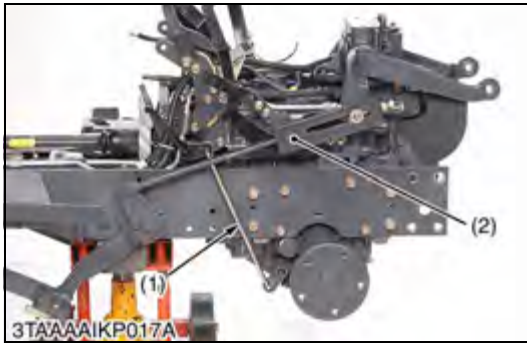

**Transaxle Assembly**

1. Remove the differential lock rod (1) and disconnect the mower link (2).
2. Remove the brake rod (4).
3. Disconnect the pipes (3). (If equipped.)
4. Disconnect the connector (5).
5. Remove the rear coupling mounting bolt (8).
6. Disconnect the power steering pipes (9).
7. Remove the speed control rod (7).
8. Remove the wire harness clamps
9. Remove the frame brackets (10).

**(When reassembling)**

- Tighten the smaller bolt (M12) first.
- Before mounting the transaxle assembly on the tractor main frame, check the flatness of the frame brackets with a straight edge securely.

Tightening torque	Transaxle assembly mounting bolt (M12)	63 to 72 N·m 6.4 to 7.4 kgf·m 47 to 53 lbf·ft
	Transaxle assembly mounting bolt (M14)	124 to 147 N·m 12.6 to 15.0 kgf·m 91.2 to 108 lbf·ft
	Rear coupling mounting bolt (M8)	24 to 27 N·m 2.4 to 2.8 kgf·m 18 to 20 lbf·ft

**(Reference)**

- Speed control rod length (7):  
371 mm (14.6 in.)

- |                           |                                 |
|---------------------------|---------------------------------|
| (1) Differential Lock Rod | (6) Front Wheel Drive Shaft     |
| (2) Mower Link            | (7) Speed Control Rod           |
| (3) Pipe                  | (8) Rear Coupling Mounting Bolt |
| (4) Brake Rod             | (9) Power Steering Pipe         |
| (5) Connector             | (10) Frame Bracket              |

9Y1210855TXS0025US0

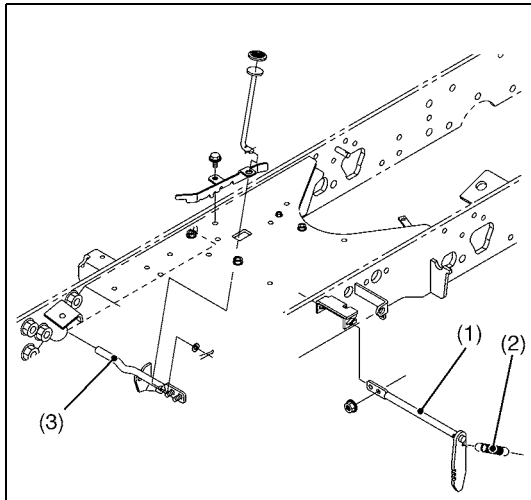

9Y1210855TXS016A

**Brake Pedal**

1. Unhook the spring (2) and remove the parking lock (1).
2. Removing the split pin then remove pin (5) from the brake arm (4).
3. Remove the brake pedal (6).

- |                  |                 |
|------------------|-----------------|
| (1) Parking Lock | (4) Brake Arm   |
| (2) Spring       | (5) Pin         |
| (3) Parking Arm  | (6) Brake Pedal |

9Y1210855TXS0026US0

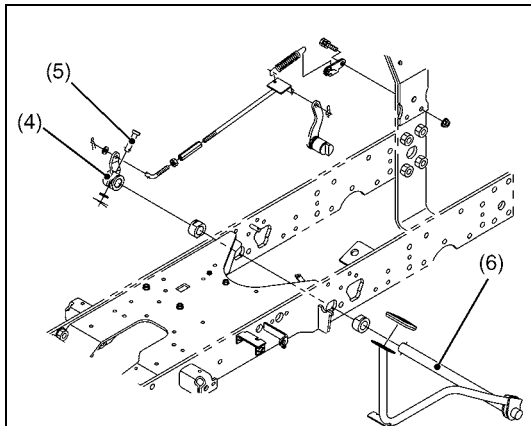

9Y1210855TXS017A

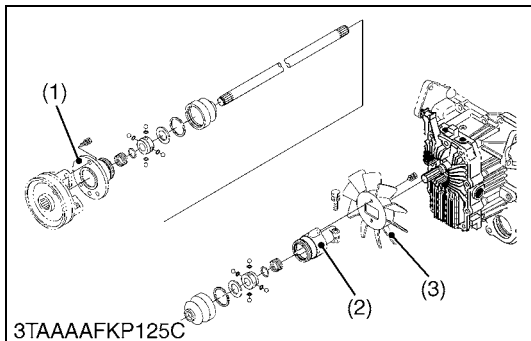

3TAAAFKP125C

**Propeller Shaft**

1. Disconnect the front coupling (1) from the engine.
2. Remove the propeller shaft assembly.
3. Remove the HST fan from the propeller shaft.

**(When reassembling)**

- Apply grease to inside of the front coupling and the rear coupling.

Tightening torque	Front coupling mounting bolt (M8)	24 to 27 N·m 2.4 to 2.8 kgf·m 18 to 20 lbf·ft
	HST fan mounting bolt (M8)	9.8 to 11 N·m 1.0 to 1.2 kgf·m 7.3 to 8.6 lbf·ft

- |                    |             |
|--------------------|-------------|
| (1) Front Coupling | (3) HST Fan |
| (2) Rear Coupling  |             |

9Y1210855TXS0027US0



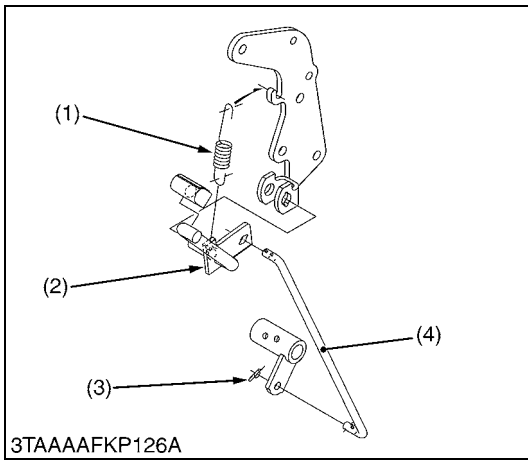

3TAAAFKP126A

**Differential Lock Pedal**

1. Remove the differential lock return spring (1).
2. Remove the rue ring cotter (3).
3. Turn and remove the differential lock pedal (2).

- |                             |                           |
|-----------------------------|---------------------------|
| (1) Spring                  | (3) Rue Ring Cotter       |
| (2) Differential Lock Pedal | (4) Differential Lock Rod |

9Y1210855TXS0028US0

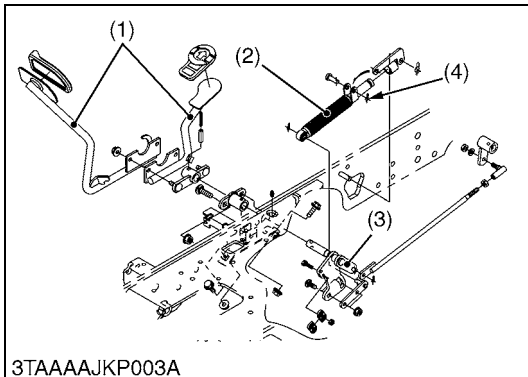

3TAAAJKP003A

**Speed Control Pedal, HST Damper and Cruise Rod**

1. Remove the speed control pedal (1).
2. Remove the rue ring cotter (4).
3. Remove the HST damper (2).
4. Remove the cruise arm (6).
5. Remove the cruise rod (5).
6. Remove the spring pin then remove the release arm (7) and cruise plate (9).

**(When reassembling)**

- Be sure to assemble the cruise spring (8) properly.

- |                         |                   |
|-------------------------|-------------------|
| (1) Speed Control Pedal | (6) Cruise Arm    |
| (2) HST Damper          | (7) Release Arm   |
| (3) HST Pedal Link      | (8) Cruise Spring |
| (4) Rue Ring Cotter     | (9) Cruise Plate  |
| (5) Cruise Rod          |                   |

9Y1210855TXS0029US0

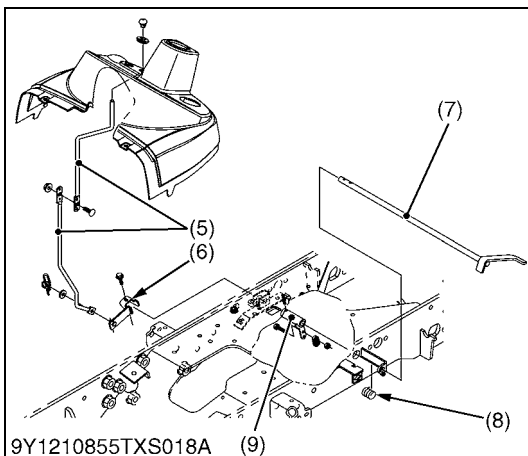

9Y1210855TXS018A (9)

# [3] DISASSEMBLING AND ASSEMBLING

## (1) Hydrostatic Transmission

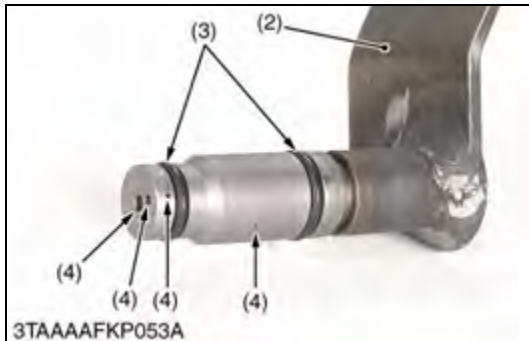
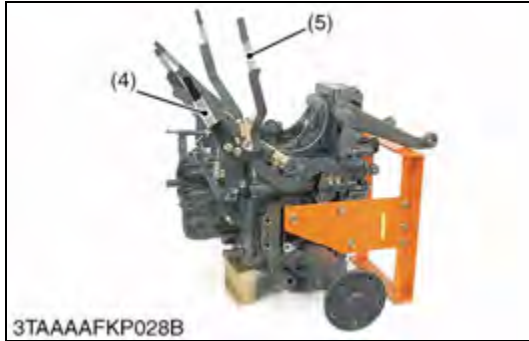

### Levers and Mower Lift Arm

1. Tap out the spring pin from the range gear shift lever (1) and front wheel drive lever (3), then remove the both levers.
2. Remove the hydraulic control lever (2).
3. Remove the PTO select lever (4) and PTO clutch control lever (5).

### (When reassembling)

- Apply grease to inside of the front coupling and rear mounting.

Tightening torque	Hydraulic control lever mounting bolt and nut	18 to 20 N·m 1.8 to 2.1 kgf·m 13 to 15 lbf·ft
-------------------	---	---

- (1) Range Gear Shift Lever
- (2) Hydraulic Control Lever
- (3) Front Wheel Drive Lever

- (4) PTO Select Lever
- (5) PTO Clutch Control Lever

9Y1210855TXS0030US0

### PTO Clutch Valve

1. Remove the stopper (1).
2. Draw out the PTO clutch valve (2) from the transaxle assembly.

### (When reassembling)

1. Clean the oil passages (4).
2. Apply the transmission fluid to the O-rings (3).

- (1) Stopper
- (2) PTO Clutch Valve
- (3) O-ring
- (4) Oil Passage

9Y1210855TXS0031US0



**Oil Cooler Cover**

1. Remove the HST front cover.
2. Remove the HST front cover (1) not to damage the oil seal (5).
3. Remove the center section (6).

**(When reassembling)**

1. Do not damage the oil seal (5).
2. Tighten the HST mounting bolts and the nut to the factory specifications.

Tightening torque	Oil cooler cover mounting bolt (M8)	18 to 20 N·m 1.8 to 2.1 kgf·m 13 to 15 lbf·ft
	Oil cooler cover mounting nut (M8)	18 to 20 N·m 1.8 to 2.1 kgf·m 13 to 15 lbf·ft

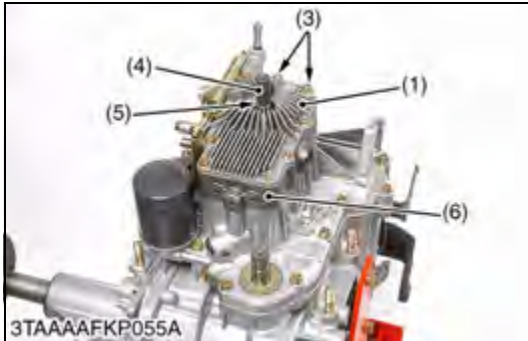

- |                        |                      |
|------------------------|----------------------|
| (1) HST Front Cover    | (4) Internal Circlip |
| (2) Transaxle Assembly | (5) Oil Seal         |
| (3) Bolt               | (6) Center Section   |

9Y1210855TXS0032US0

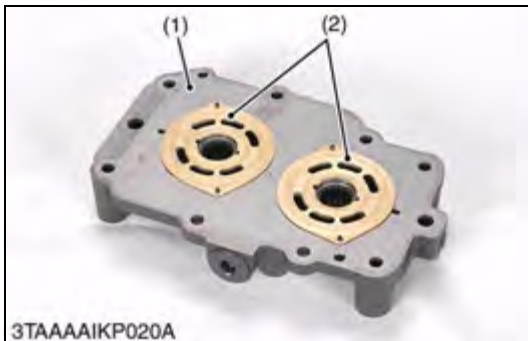

**Center Section and Valve Plates**

1. Remove the valve plates (2).

**(When reassembling)**

1. Check the direction of the groove (3).
2. Install the valve plates (2) to the anchor pins (4) securely.
3. Install the groove of the valve plate (pump plate) to the engine side.

- |                    |                |
|--------------------|----------------|
| (1) Center Section | (3) Groove     |
| (2) Valve Plate    | (4) Anchor Pin |

9Y1210855TXS0033US0

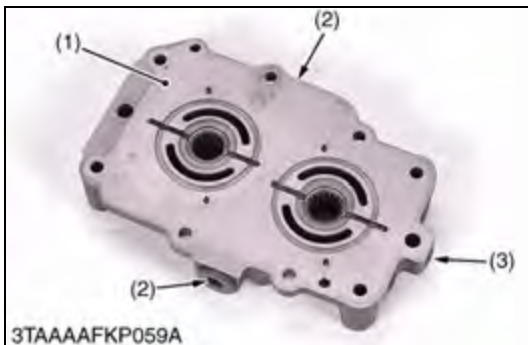
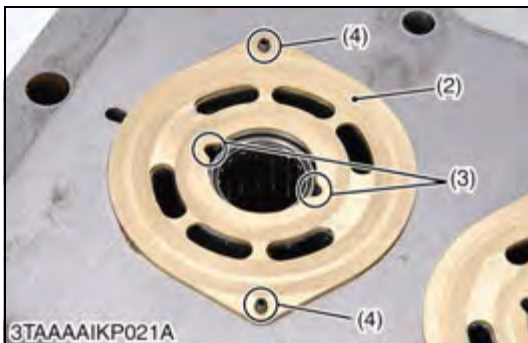

**Check and High Pressure Relief Valve Plug**

1. Remove the check and high pressure relief plug (G 1/2).

**(When reassembling)**

Tightening torque	Check and high pressure relief valve plug (G 1/2)	59 to 78 N·m 6.0 to 8.0 kgf·m 44 to 57 lbf·ft
-------------------	---	---

- |                    |          |
|--------------------|----------|
| (1) Center Section | (3) Plug |
| (2) Plug           |          |

9Y1210855TXS0034US0

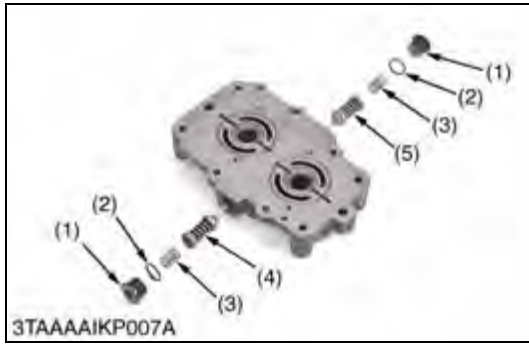

**Check and High Pressure Relief Valve**

1. After removing the plug (1), draw out the spring (3) and the check and high pressure relief valve assembly (4), (5).

**(When reassembling)**

- Be careful not to damage the O-ring (2) on the plug (1).
- Since there is an orifice (1.5 mm, 0.059 in.) in the check and relief valve body (reverse) (5), re-install the check and relief valve (4), (5) to their original positions.

- |            |                                      |
|------------|--------------------------------------|
| (1) Plug   | (4) Check and Relief Valve (Forward) |
| (2) O-ring | (5) Check and Relief Valve (Reverse) |
| (3) Spring |                                      |

9Y1210855TXS0035US0



**Cylinder Block**

1. Remove the gasket (1).
2. Remove the O-ring (2).
3. Remove the cylinder block assembly (4), (5) from the transaxle.

**(When reassembling)**

- Turn the disassembling and the assembling stand vertically.
- Install the cylinder block assembly (4), (5) to the shafts not to drop the pistons from the cylinder block assembly (4), (5) carefully.

- |   |  |
|---|--|
| (1) Gasket                              | (5) Cylinder Block Assembly (Pump Side)  |
| (2) O-ring                              | (6) Cylinder Block Assembly (Motor Side) |
| (3) Pump Shaft                          |  |
| (4) Cylinder Block Assembly (Pump Side) |  |

9Y1210855TXS0036US0



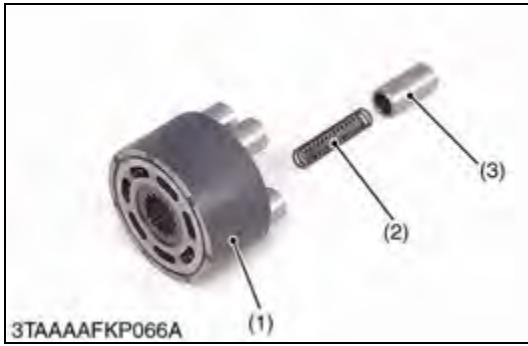

**Cylinder Block and Piston**

1. Remove the piston (3) and the spring (2) from the cylinder block (1).

**(When reassembling)**

- Apply clean transmission oil to the cylinder block and the piston.

■ **NOTE**

- **Be careful not to damage the surface of the cylinder block and the piston.**

- (1) Cylinder Block
- (2) Spring

- (3) Piston

9Y1210855TXS0037US0



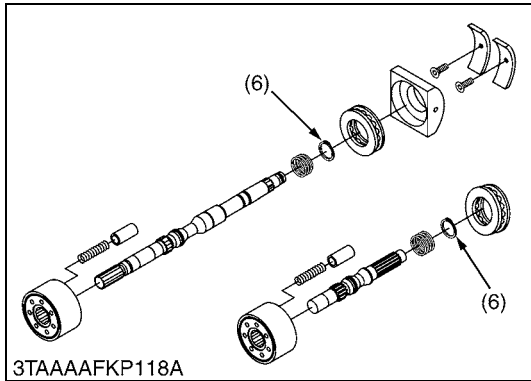

3TAAAAFKP118A

**Swashplate and Trust Roller Bearing**

1. Remove the circlip (6) from the pump shaft (3) and the motor shaft (1).
2. Remove the thrust bearing (2).
3. Remove the swashplate (5) and the thrust roller bearing (4).

**(When reassembling)**

- Apply clean transmission oil to the cradle bearing and the trunnion arm.
- Hold the slot guide with a minus screw driver.
- Apply clean transmission oil to the thrust roller bearing.

- |                           |                    |
|---------------------------|--------------------|
| (1) Motor Shaft           | (5) Swashplate     |
| (2) Thrust Bearing        | (6) Circlip        |
| (3) Pump Shaft            | (7) Slot Guide     |
| (4) Thrust Roller Bearing | (8) Cradle Bearing |

9Y1210855TXS0038US0



3TAAAAFKP067A

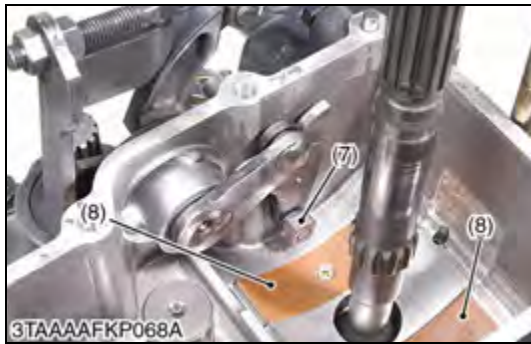

3TAAAAFKP068A



3TAAAAFKP069A

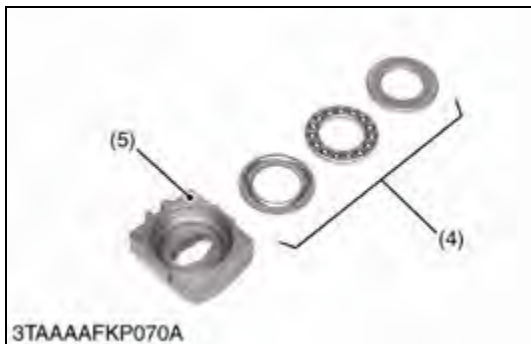

3TAAAAFKP070A

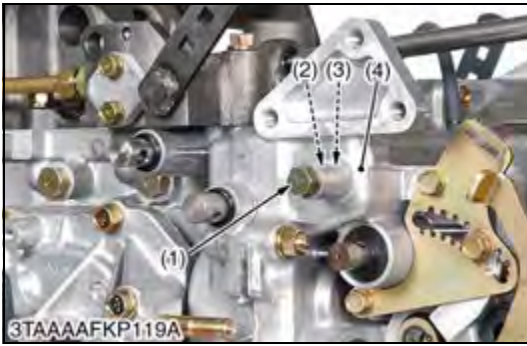

### 4WD Detent Ball

1. Remove the 4WD detent bolt (1), the detent spring (2) and the detent ball (3) before removing the transaxle front case, not to drop the detent ball (3) into the transaxle case.

- |                     |                          |
|---------------------|--------------------------|
| (1) 4WD Detent Bolt | (3) Detent Ball          |
| (2) Detent Spring   | (4) Transaxle Front Case |

9Y1210855TXS0039US0

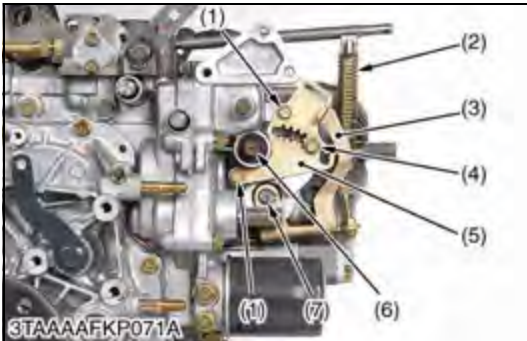

### Neutral Arm and Trunnion Arm

1. Disconnect the neutral spring (2) from the HST front cover.
2. Loosen the neutral adjuster (5).
3. Remove the external circlip (7).
4. Remove the bolts (1).
5. Remove the neutral adjuster (5) and the neutral arm (3).
6. Remove the trunnion arm (6).

#### (When reassembling)

- Adjust the HST neutral position. Refer to "**Checking and Adjusting**" section.

- |                    |                      |
|--------------------|----------------------|
| (1) Bolt           | (5) Neutral Adjuster |
| (2) Neutral Spring | (6) Trunnion Arm     |
| (3) Neutral Arm    | (7) External Circlip |
| (4) Lock Screw     |                      |

9Y1210855TXS0040US0



## (2) Hydraulic Cylinder

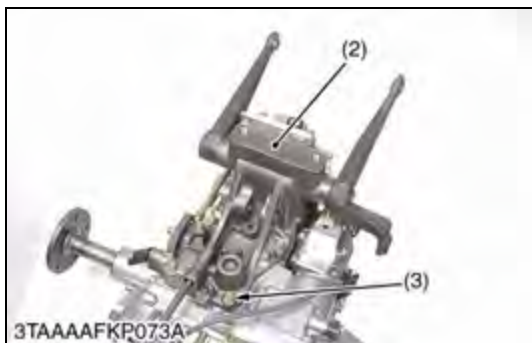
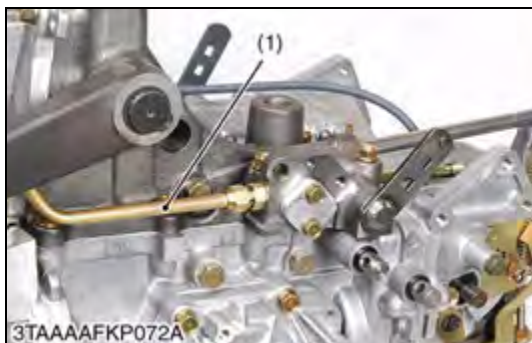

### Hydraulic Cylinder

1. Disconnect the delivery pipe (1).
2. Remove the hydraulic cylinder mounting bolts (3).
3. Remove the hydraulic cylinder (2).

#### (When reassembling)

- Apply liquid gasket (Three Bond 1208D or equivalent) to the joint surface of the transaxle case to the hydraulic cylinder.

Tightening torque	Hydraulic cylinder mounting bolt	40 to 44 N·m 4.0 to 4.5 kgf·m 29 to 32 lbf·ft
-------------------	----------------------------------	---

- (1) Delivery Pipe (3) Bolt  
(2) Hydraulic Cylinder

9Y1210855TXS0041US0



### (3) Transaxle Shafts

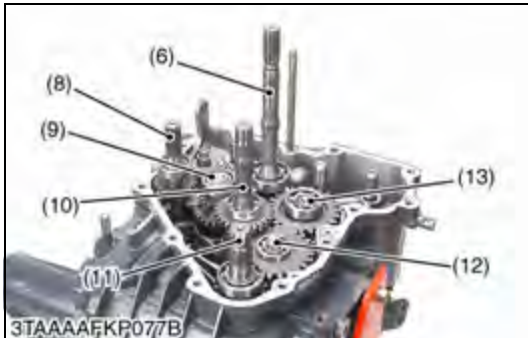
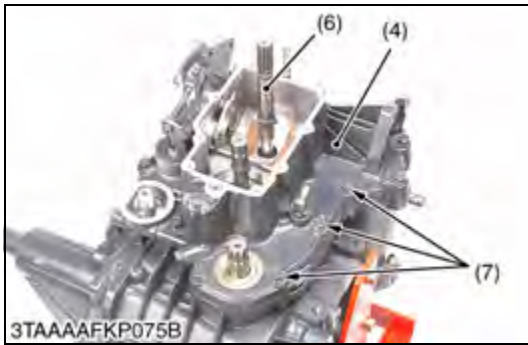
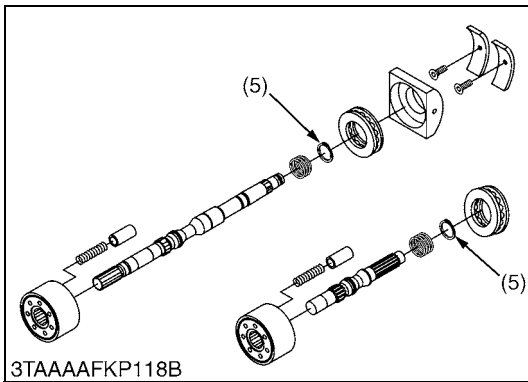
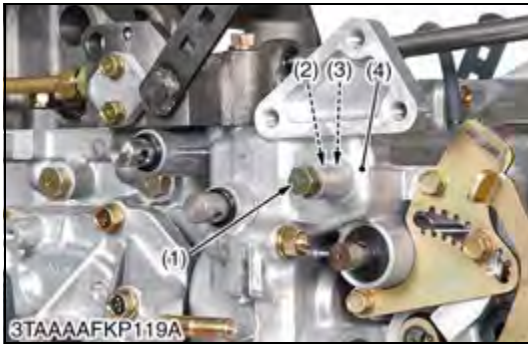

#### Transaxle Case Front Cover

■ **NOTE**

- Before removing the transaxle case front cover (4), remove the 4WD detent bolt (1), the detent spring (2) and the detent ball (3) from the transaxle case front cover (4).
- Remove the circlip (5) from the HST pump shaft (PTO shaft) from the HST pump shaft (6) and the HST motor shaft securely.

1. Remove the transaxle case front cover mounting bolts (7).
2. Remove the transaxle case front cover (4) as an unit.

**(When reassembling)**

- Apply liquid gasket (Three Bond 1208D or equivalent) to the joint surface of the transaxle case to the front cover.

Tightening torque	Transaxle case front cover mounting bolt (M10)	39 to 44 N·m 4.0 to 4.4 kgf·m 29 to 32 lbf·ft
-------------------	--	---

- |                                |                               |
|--------------------------------|-------------------------------|
| (1) 4WD Detent Bolt            | (8) Front Wheel Drive Shaft   |
| (2) Detent Spring              | (9) Spiral Bevel Pinion Shaft |
| (3) Detent Ball                | (10) HST Motor Shaft          |
| (4) Transaxle Case Front Cover | (11) Mid-PTO Shaft            |
| (5) Circlip                    | (12) Mid-PTO Idle Gear Shaft  |
| (6) HST Pump Shaft (PTO Shaft) | (13) PTO Select Shaft         |
| (7) Front Cover Mounting Bolt  |                               |

9Y1210855TXS0042US0



### Hydraulic Pump Assembly

1. Remove the hydraulic pump assembly mounting bolt (2), (3).
2. Remove the hydraulic pump assembly (1) as an unit from the transaxle case.

#### (When reassembling)

- Apply transmission oil to the O-rings.
- Since the mounting bolt (2) is installed through the hydraulic pump to the transaxle case, bind the sealing tape to the mounting bolt (2) securely.



Tightening torque	Hydraulic pump assembly mounting bolt (M6)	7.9 to 8.8 N·m 0.80 to 0.90 kgf·m 5.8 to 6.5 lbf·ft
	Hydraulic pump assembly mounting bolt (M8)	18 to 20 N·m 1.8 to 2.1 kgf·m 13 to 15 lbf·ft

- |                             |            |
|-----------------------------|------------|
| (1) Hydraulic Pump Assembly | (5) O-ring |
| (2) Bolt (Through Bolt)     | (6) O-ring |
| (3) Bolt                    | (7) O-ring |
| (4) O-ring                  |            |

9Y1210855TXS0043US0





### Rear PTO Cover Assembly

1. Remove the rear PTO cover mounting bolts (1).
2. Remove the rear PTO cover (2).
3. Remove the rear PTO shaft (5) from the rear PTO cover (2).

#### (When reassembling)

- Pull the 11T PTO select shaft with the bearing approximately the bearing thickness.
- Apply liquid gasket (Three Bond 1208D or equivalent) to the joint surface of transaxle case to the rear PTO cover.
- Bind the vinyl tape to the rear PTO shaft not to damage the oil seal.

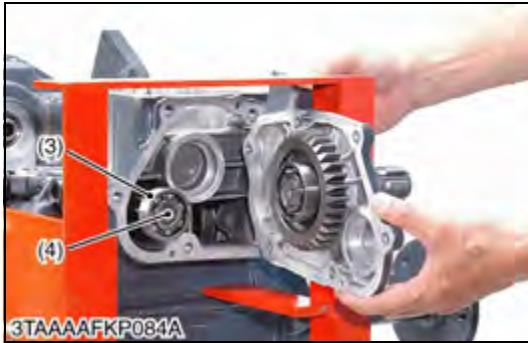

Tightening torque	Rear PTO cover mounting bolt (M8)	18 to 20 N·m 1.8 to 2.1 kgf·m 13 to 15 lbf·ft
-------------------	-----------------------------------	---

- |                          |                    |
|--------------------------|--------------------|
| (1) Bolt                 | (5) Rear PTO Shaft |
| (2) Rear PTO Cover       | (6) Oil Seal       |
| (3) Bearing              | (7) Vinyl Tape     |
| (4) 11T PTO Select Shaft |                    |

9Y1210855TXS0044US0

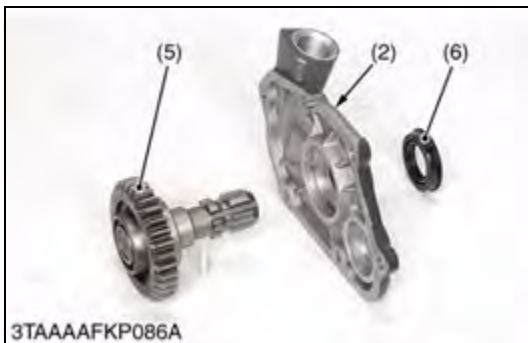
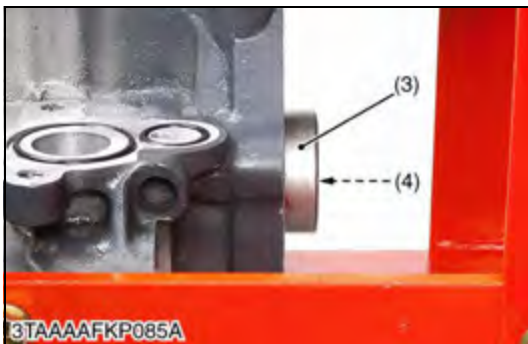

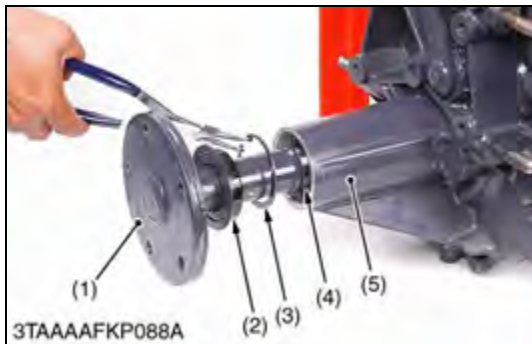

### Rear Axle (LH)

■ **NOTE**

- **Prepare a specially bent snap ring pillar.**
1. Draw out the oil seal with a screw driver.
  2. Remove the internal circlip from the rear axle case.
  3. Draw out the rear axle from the rear axle case.

**(When reassembling)**

- Do not damage the oil seal.

- |                      |                    |
|----------------------|--------------------|
| (1) Rear Axle        | (4) Ball Bearing   |
| (2) Oil Seal         | (5) Rear Axle Case |
| (3) Internal Circlip |                    |

9Y1210855TXS0045US0

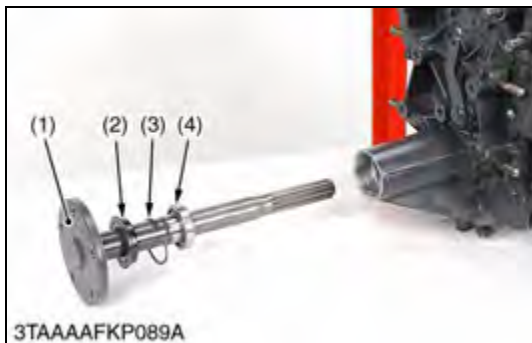





### Rear Axle Case (RH)

1. Remove the rear axle case (RH) mounting bolts.
2. Remove the rear axle case (RH) (1) as an assembly from the transaxle case.

#### ■ NOTE

- Since the adjusting shims are installed behind the 37T spiral bevel gear, check the shims.
3. Remove the 37T spiral bevel gear (2).
  4. Remove the 10T final gear shaft (3).
  5. Remove the 66T final gear with the differential lock shift fork.

#### (When reassembling)

- Apply liquid gasket (Three Bond 1208D or equivalent) to the joint surface of transaxle case to the rear axle (RH) case.

Tightening torque	Rear axle case (RH) mounting bolt (M8)	18 to 20 N·m 1.8 to 2.1 kgf·m 13 to 15 lbf·ft
-------------------	--	---

- |                           |  |
|---------------------------|--|
| (1) Rear Axle Case (RH)   | (3) 10T Final Gear Shaft (Brake Shaft) |
| (2) 37T Spiral Bevel Gear | (4) 66T Final Gear                     |

9Y1210855TXS0046US0



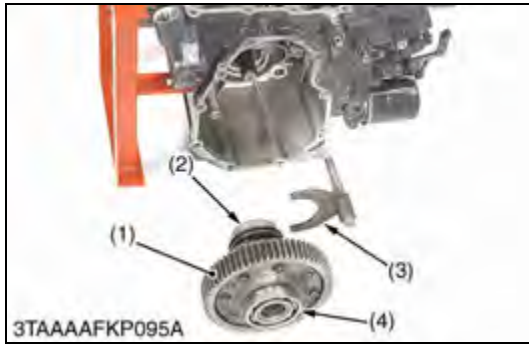

**66T Final Gear**

1. Remove the bearing (2) with a puller.
2. Remove the bearing (4) with a puller.
3. Remove the differential lock shifter (5) and 66T final gear (6).
4. Put parting marks on the differential pinions (12), (16) and the differential side gears (9), (14).
5. Tap out the differential pinion shaft (8).
6. Remove the differential pinions (12), (16), the differential pinion washers (13), (17), differential side gears (9), (14) and the differential side gear washers (10), (15).



**(When reassembling)**

- Install the differential pinion and differential gear, aligning the parting marks.
- Lock the differential pinion shaft (8) by setting the key (11).

Tightening torque	66T final gear mounting bolt	61 to 70 N·m 6.2 to 7.2 kgf·m 45 to 52 lbf·ft
-------------------	------------------------------	---

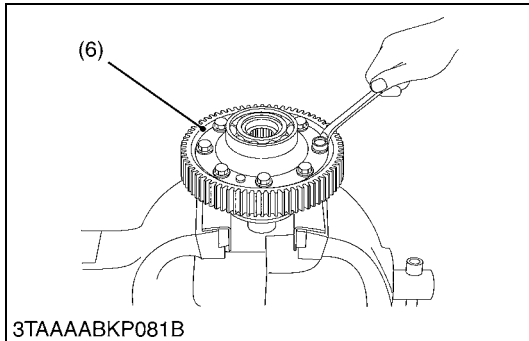

- |                                  |                                    |
|----------------------------------|------------------------------------|
| (1) 66T Final Gear               | (10) Differential Side Gear Washer |
| (2) Bearing                      | (11) Key                           |
| (3) Differential Lock Shift Folk | (12) Differential Pinion           |
| (4) Bearing                      | (13) Differential Pinion Washer    |
| (5) Differential Lock Shifter    | (14) Differential Side Gear        |
| (6) 66T Final Gear               | (15) Differential Side Gear Washer |
| (7) Differential Case            | (16) Differential Pinion           |
| (8) Differential Pinion Shaft    | (17) Differential Pinion Washer    |
| (9) Differential Side Gear       |                                    |

9Y1210855TXS0047US0

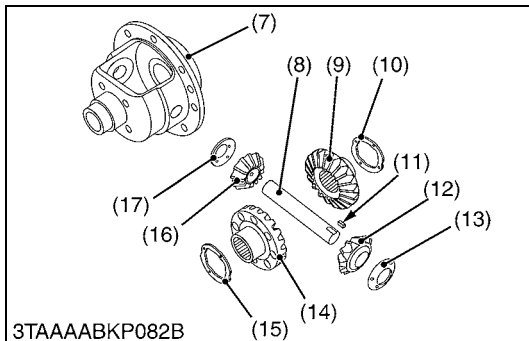

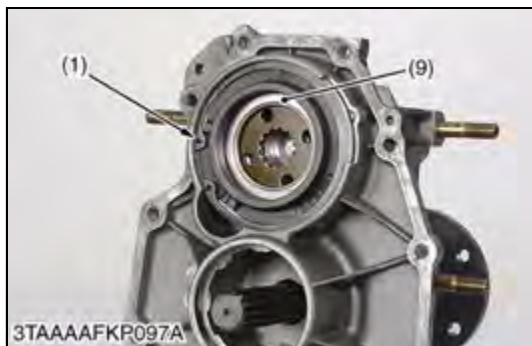

**Rear Axle Case, RH and Brake**

1. Remove the internal circlip (1).
2. Remove the shim (9), the bearing holder (8) and the other brake parts from the brake case.

**(When reassembling)**

- Apply grease to the steel balls.
- Be careful not to damage the O-ring on the brake cam lever.
- Check that the brake cam lever moves smoothly.

- |                      |                    |
|----------------------|--------------------|
| (1) Internal Circlip | (6) Brake Disc     |
| (2) Brake Cam Lever  | (7) Friction Plate |
| (3) External Circlip | (8) Bearing Holder |
| (4) Steel Ball       | (9) Shim           |
| (5) Actuator         |                    |

9Y1210855TXS0048US0

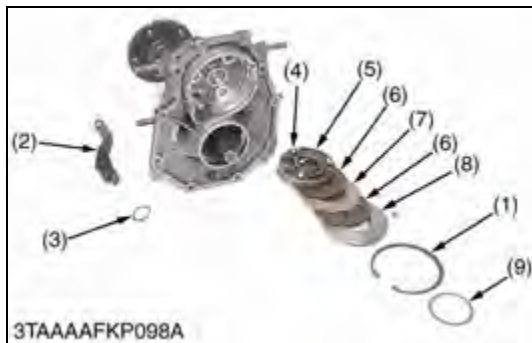

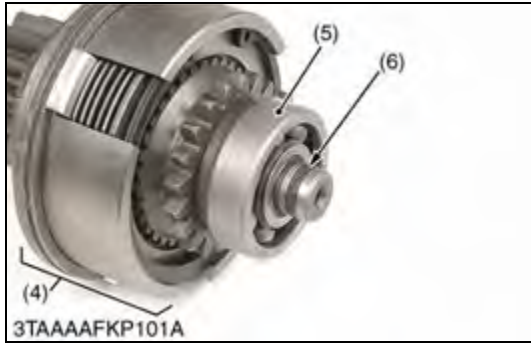
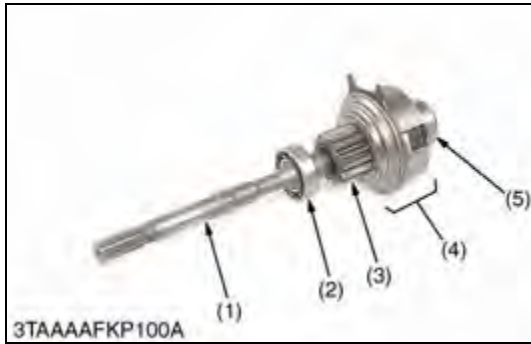

**PTO Clutch Assembly**

1. Remove the bearing (2).
2. Remove the external circlip and the clutch gear (3).
3. Remove the seal rings (6).
4. Remove the bearing (5).
5. Remove the external circlip (18) using a clutch spring compressor.
6. Disassembling the clutch pack inner parts as show in the figure.

**(When reassembling)**

- Change the seal rings (6) with a new one.

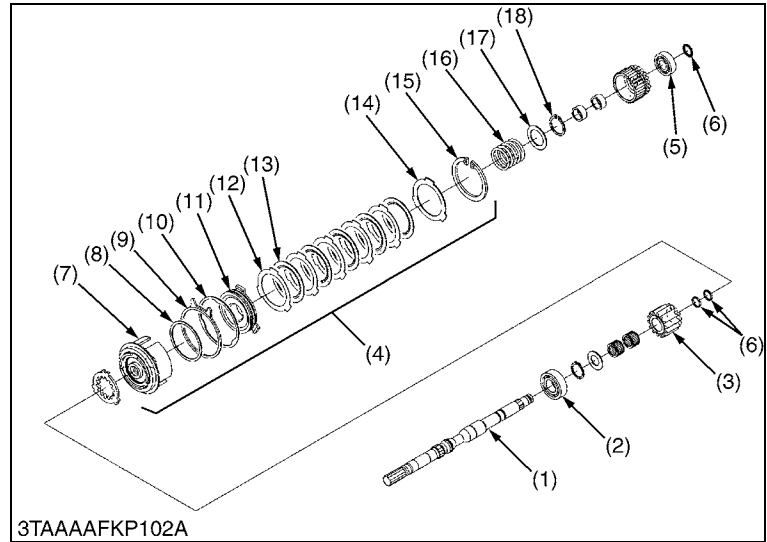

- |                                   |                               |
|-----------------------------------|-------------------------------|
| (1) Pump Shaft (PTO Clutch Shaft) | (11) Clutch Piston            |
| (2) Bearing                       | (12) Separate Plate           |
| (3) Clutch Gear                   | (13) Disc Plate               |
| (4) Clutch Pack                   | (14) Backing Plate            |
| (5) Bearing                       | (15) Internal Circlip         |
| (6) Seal Ring                     | (16) Brake Spring             |
| (7) Clutch Case                   | (17) Washer                   |
| (8) O-ring                        | (18) External Circlip         |
| (9) Brake Disc                    | (19) Clutch Spring Compressor |
| (10) Brake Plate                  |                               |

9Y1210855TXS0049US0



## (4) Assembling Shafts

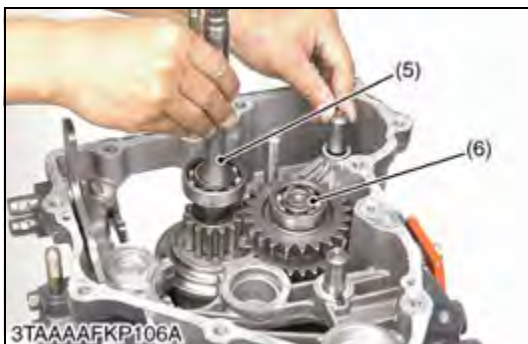
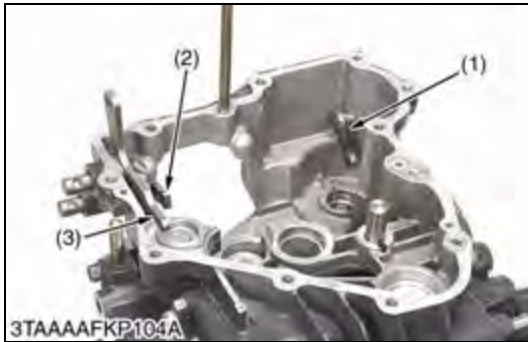

### Assembling Select Arms and HST Pump Shaft (PTO Clutch Shaft)

1. Install the PTO select arm (1).
2. Install the range shift arm (2) and the front wheel drive shift arm (3).
3. Install the idle gear shaft.

#### ■ NOTE

- **Install the rear PTO cover and the PTO select gear shaft before installing HST pump shaft assembly.**
4. After installing the rear PTO cover to the transaxle case, install the PTO select gear shaft (6).
  5. Install the HST pump shaft (PTO clutch shaft) (5).

#### **(When reassembling)**

- Be careful not to damage the O-rings on the arms.

- |                                 |  |
|---------------------------------|--|
| (1) PTO Select Arm              | (5) HST Pump Shaft<br>(PTO Clutch Shaft) |
| (2) Range Shift Arm             | (6) PTO Select Gear Shaft                |
| (3) Front Wheel Drive Shift Arm |  |
| (4) Mid-PTO Idle Gear Shaft     |  |

9Y1210855TXS0050US0

**Front Wheel Drive Shaft, Shifter, Spiral Bevel Pinion Shaft and Mid-PTO Shaft**

1. Install the front drive shaft (1).
2. Install the shifter (2) and the spiral bevel pinion shaft (3) together.
3. Install the mid-PTO idle gear shaft (5) and the mid-PTO shaft (6) and the HST motor shaft (4) together.

- |                               |                             |
|-------------------------------|-----------------------------|
| (1) Front Wheel Drive Shaft   | (4) HST Motor Shaft         |
| (2) Shifter                   | (5) Mid-PTO Idle Gear Shaft |
| (3) Spiral Bevel Pinion Shaft | (6) Mid-PTO Shaft           |

9Y1210855TXS0051US0

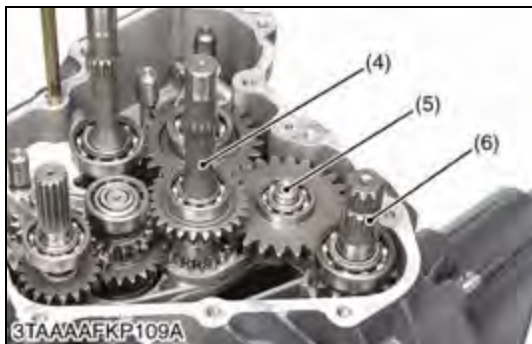

## [4] SERVICING

### (1) Hydrostatic Transmission

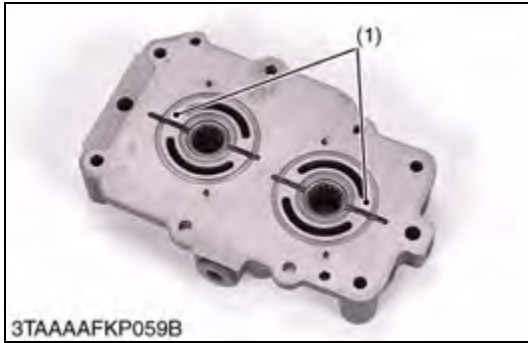

#### Center Section

1. Check the center section surface (1) for scratches or wear.
2. If deep scratch or excessive wear is found, replace the hydrostatic transmission assembly.

(1) Center Section Surface

9Y1210855TXS0052US0

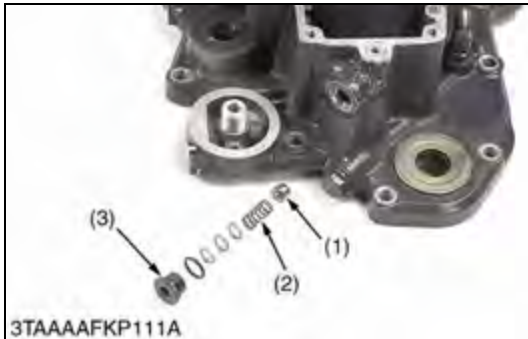

#### Charge Relief Valve

1. Check the charge relief valve (1) and the spring (2).
2. If damaged are found, replace it.

(1) Charge Relief Valve

(3) Plug

(2) Spring

9Y1210855TXS0053US0

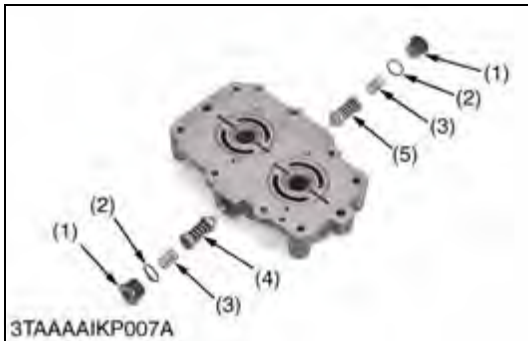

#### Check and High Pressure Relief Valve

1. Check the check and high pressure relief valve (4), (5) for scratches and damage.
2. Check the spring (3) for breakage and wear.
3. If anything are unusual, replace the check and high pressure relief valve as complete assembly.

#### NOTE

- Check and high pressure relief valve (reverse) has a pin hole (1.5 mm, 0.059 in.).

(1) Plug

(4) Check and High Pressure Relief Valve (Forward)

(2) O-ring

(5) Check and High Pressure Relief Valve (Reverse)

(3) Spring

(Reverse)

9Y1210855TXS0054US0

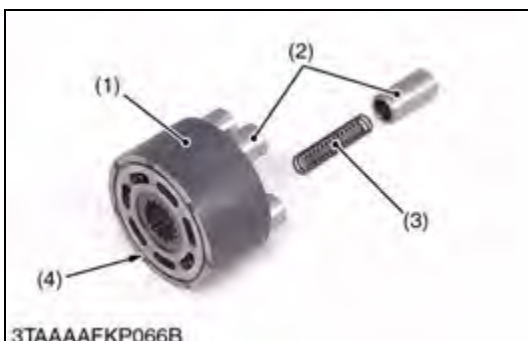

#### Cylinder Block Assembly

1. Check the cylinder blocks (1) and the pistons (2) for scratches and wear.
2. If there are scratch or worn, replace the cylinder block assembly.
3. Check the pistons for their free movement in the cylinder block bores.
4. If the piston or the cylinder block is scored, replace the cylinder block assembly.
5. Check the polished face (4) of the cylinder block for scoring. If it is scored, replace the cylinder block assembly.

#### IMPORTANT

- Do not interchange the pistons between the pump cylinder block and the motor cylinder block. Pistons and cylinder blocks are matched.

(1) Cylinder Block

(3) Spring

(2) Piston

(4) Polished Face

9Y1210855TXS0055US0

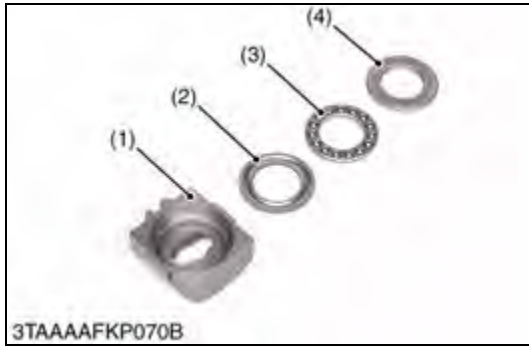

**Thrust Washer, Thrust Roller Bearing, Thrust Plate and Cradle Bearing**

1. Check the thrust bearing (3) for scratches and excessive wear.
2. If it is worn, replace it.
3. Check the thrust plate (4) for scratches and excessive wear. If it is worn or scored, replace it.
4. Check the cradle bearing (5) for excessive wear. If it is worn, replace it.

- |                    |                    |
|--------------------|--------------------|
| (1) Swashplate     | (4) Thrust Plate   |
| (2) Thrust Washer  | (5) Cradle Bearing |
| (3) Thrust Bearing |                    |

9Y1210855TXS0056US0

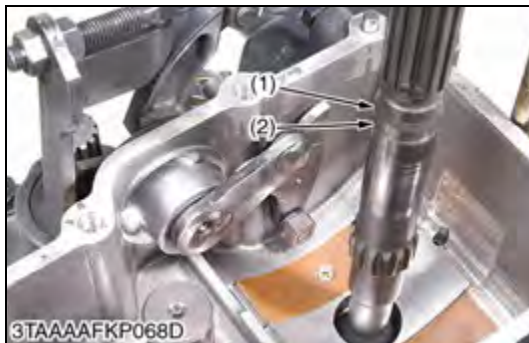
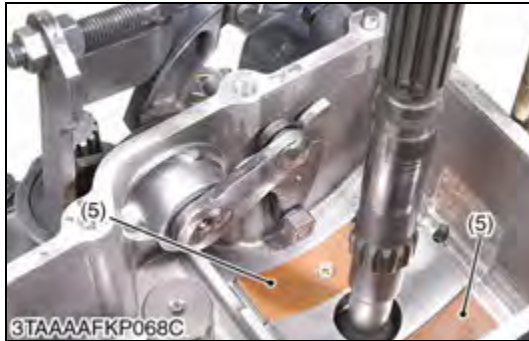

**Pump Shaft (PTO Clutch Shaft)**

1. Check the seal surface (1) and the bearing surface.
2. If the pump shaft is rough or grooved, replace it.
3. If the ball bearing or the needle bearing is worn, replace it.

- |                  |                     |
|------------------|---------------------|
| (1) Seal Surface | (2) Bearing Surface |
|------------------|---------------------|

9Y1210855TXS0057US0

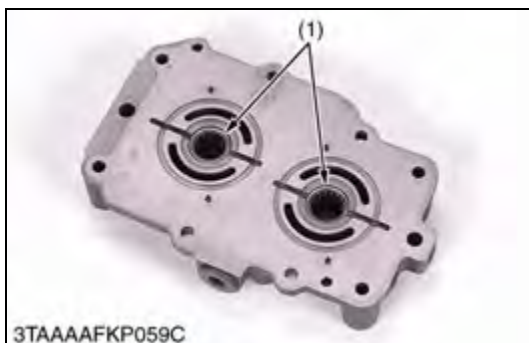
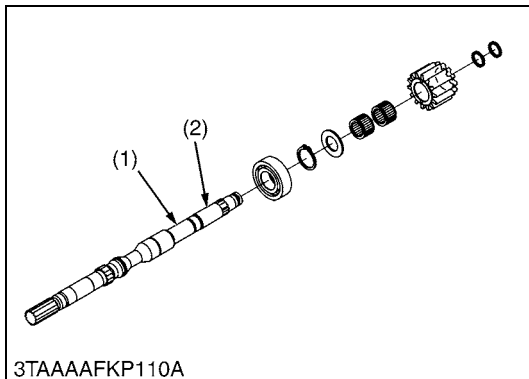

**Needle Bearing**

1. Check the needle bearing (1) for wear.
2. If the needle bearing (1) are worn, replace them.

- |                    |
|--------------------|
| (1) Needle Bearing |
|--------------------|

9Y1210855TXS0058US0

## (2) Transaxle Case

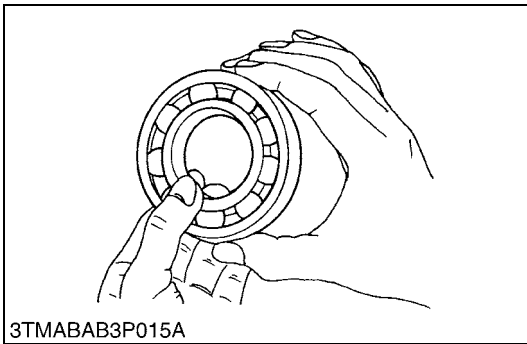

3TMABAB3P015A

### Bearing

1. Hold the inner race, and push and pull the outer race in all directions to check wear and roughness.
2. Apply the transmission oil to the bearing, and hold the inner race.  
And turn the outer race to check rotation.
3. If there are any damaged, replace the bearing.

9Y1210855TXS0059US0

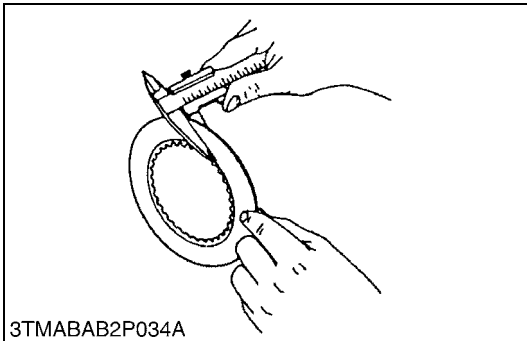

3TMABAB2P034A

### PTO Clutch Disc Wear

1. Measure the thickness of PTO clutch disc with vernier calipers.
2. If the thickness is less than the allowable limit, replace it.

Thickness of PTO clutch disc	Factory specification	1.50 to 1.70 mm 0.0591 to 0.0669 in.
	Allowable limit	1.35 mm 0.0531 in.

9Y1210855TXS0060US0

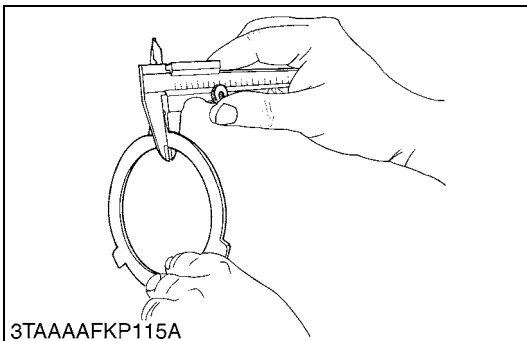

3TAAAFKP115A

### Separate Plate and Back Plate Wear

1. Measure the thickness of pressure plate and steel back with vernier calipers.
2. If the thickness is less than the allowable limit, replace it.

Thickness of separate plate	Factory specification	0.9450 to 1.055 mm 0.03721 to 0.04153 in.
	Allowable limit	0.80 mm 0.031 in.

Thickness of back plate	Factory specification	1.9 to 2.1 mm 0.075 to 0.082 in.
	Allowable limit	1.85 mm 0.0728 in.

9Y1210855TXS0061US0

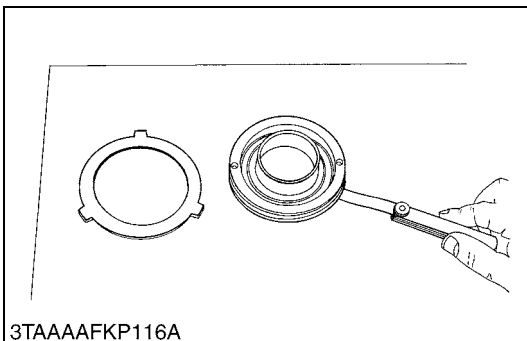

3TAAAFKP116A

### Flatness of Clutch Piston, Pressure Plate and Steel Plate

1. Place the part on a surface plate.
2. Check the flatness by inserting a feeler gauge (allowable limit size) underneath it at least four points.
3. If the gauge can be inserted, replace it.

Flatness of clutch piston	Allowable limit	0.15 mm 0.0059 in.
---------------------------	-----------------	-----------------------

Flatness of pressure plate and steel plate	Allowable limit	0.20 mm 0.0079 in.
--	-----------------	-----------------------

9Y1210855TXS0062US0



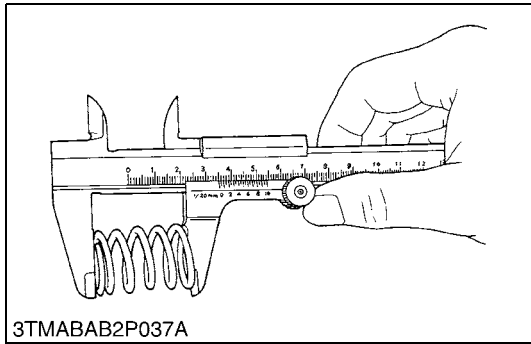

**Clutch Spring Free Length**

1. Measure the free length of spring with vernier calipers.
2. If the measurement is less than the allowable limit, replace it.

Clutch spring free length	Factory specification	38.5 mm 1.52 in.
	Allowable limit	34.5 mm 1.36 in.

9Y1210855TXS0063US0

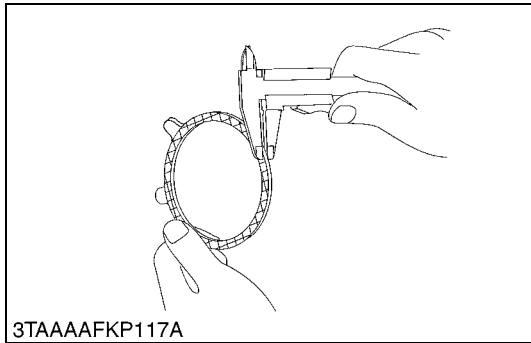

**PTO Brake Disc Wear**

1. Measure the PTO brake disc thickness with a vernier caliper.
2. If the thickness is less than allowable limit, replace it.

PTO brake disc thickness	Factory specification	2.90 to 3.10 mm 0.115 to 0.122 in.
	Allowable limit	2.70 mm 0.11 in.

9Y1210855TXS0064US0

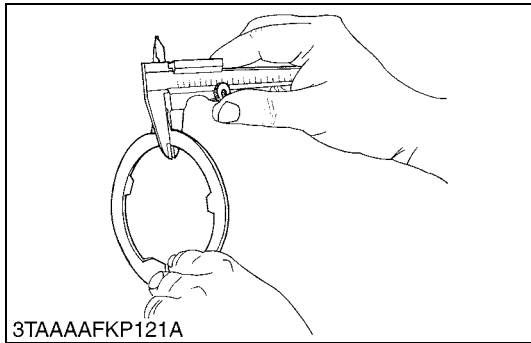

**PTO Brake Plate**

1. Measure the PTO brake plate thickness with a vernier caliper.
2. If the thickness is less than allowable limit, replace it.

PTO brake plate thickness	Factory specification	1.9 to 2.1 mm 0.075 to 0.082 in.
	Allowable limit	1.85 mm 0.0728 in.

9Y1210855TXS0065US0

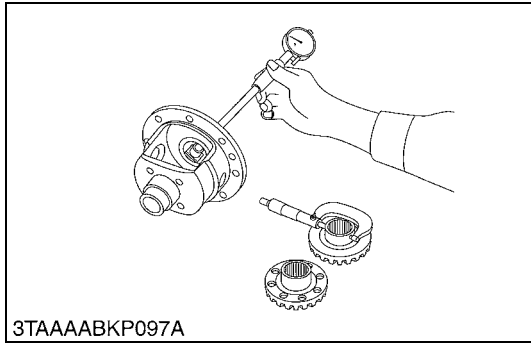

**Clearance between Differential Case and Differential Side Gear**

1. Measure the differential side gear boss O.D. with an outside micrometer.
2. Measure the differential case I.D. with a cylinder gauge and calculate the clearance.
3. If the clearance exceeds the allowable limit, replace faulty parts.

Clearance between differential case and differential side gear	Factory specification	0.0500 to 0.151 mm 0.00197 to 0.00594 in.
	Allowable limit	0.30 mm 0.012 in.

Differential case I.D.	Factory specification	38.000 to 38.062 mm 1.4961 to 1.4985 in.
Differential side gear O.D.	Factory specification	37.911 to 37.950 mm 1.4926 to 1.4940 in.

9Y1210855TXS0066US0

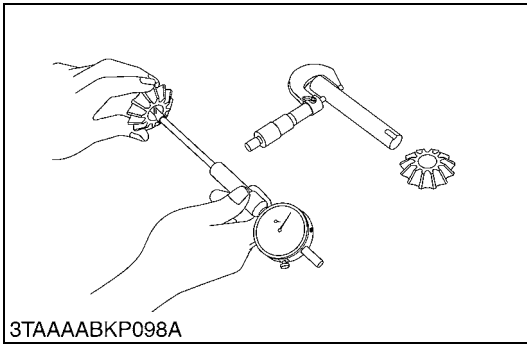

**Clearance between Differential Pinion Shaft and Differential Pinion**

1. Measure the differential pinion shaft O.D. with an outside micrometer.
2. Measure the differential pinion I.D. with a cylinder gauge, and calculate the clearance.
3. If the clearance exceeds the allowable limit, replace faulty parts.

Clearance between differential pinion shaft and differential pinion	Factory specification	0.0800 to 0.122 mm 0.00315 to 0.00480 in.
	Allowable limit	0.30 mm 0.012 in.

Differential pinion I.D.	Factory specification	20.060 to 20.081 mm 0.78977 to 0.79059 in.
Differential pinion shaft O.D.	Factory specification	19.959 to 19.980 mm 0.78579 to 0.78661 in.

9Y1210855TXS0067US0

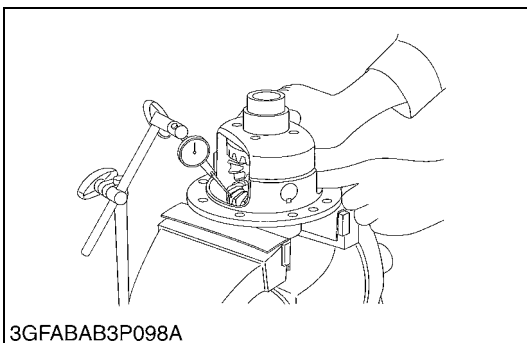

**Backlash between Differential Pinion and Differential Side Gear**

1. Secure the differential case with a vise.
2. Set the dial indicator (lever type) with its finger on the tooth of the differential side gear.
3. Press differential pinion and side gear against the differential case.
4. Hold the differential pinion and move the differential side gear to measure the backlash.
5. If the backlash exceeds the allowable limit, adjust with differential side gear shims.

Backlash between differential pinion and differential side gear	Factory specification	0.15 to 0.30 mm 0.0059 to 0.011 in.
	Allowable limit	0.40 mm 0.016 in.

**(Reference)**

- Thickness of shims:  
1.5 mm (0.059 in.)  
1.6 mm (0.063 in.)  
1.7 mm (0.067 in.)

9Y1210855TXS0068US0

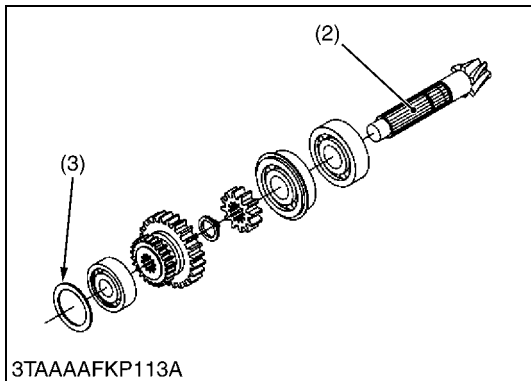

**Backlash between Spiral Bevel Pinion Gear and Bevel Gear**

1. Temporarily assemble the spiral bevel pinion gear (2) and the bevel gear (1) in the transaxle case.
2. Hold the wire of solder or plastigauge on the bevel gear teeth upper surface (A).
3. Turn the front drive shaft one turn clockwise by hands.
4. Measure the backlash between the spiral bevel pinion gear and the bevel gear.
5. If the backlash exceeds the factory specifications, adjust the shims (3), (4).

Backlash between spiral bevel pinion and bevel gear	Factory specification	0.10 to 0.30 mm 0.0040 to 0.011 in.
---	-----------------------	--

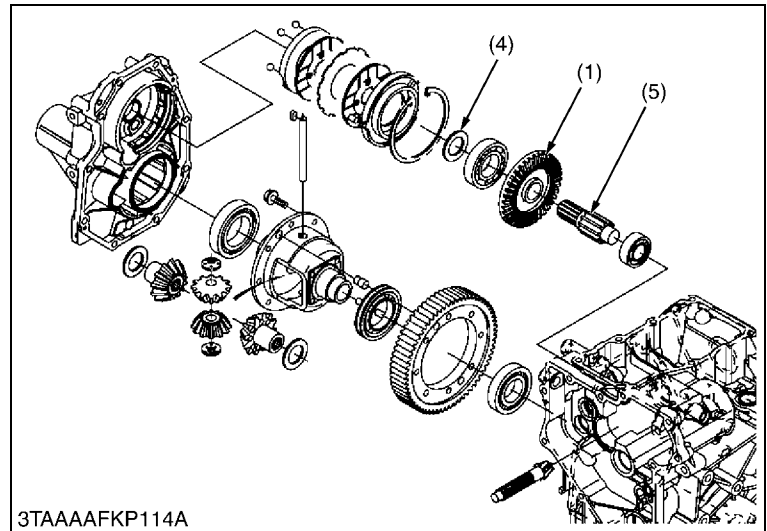

- (1) Bevel Gear
- (2) Spiral Bevel Pinion Gear
- (3) Shim
- (4) Shim
- (5) Final Gear Shaft (Brake Shaft)

(A) Bevel Gear Teeth Upper Surface

9Y1210855TXS0069US0



**Brake Cam Lever Movement**

1. Move the brake cam lever by hand to check its movement.
2. If its movement is heavy, refine the brake cam with a emery paper.

9Y1210855TXS0070US0

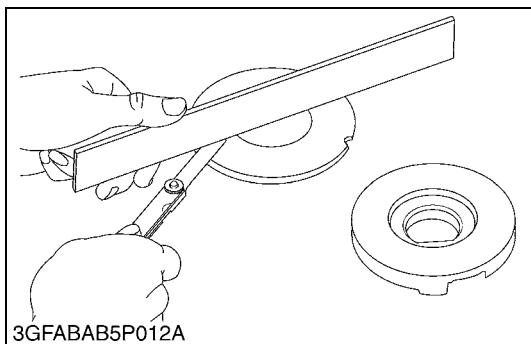

**Flatness of Actuator and Bearing Holder**

1. Place a straightedge of 150 mm (5.91 in.) or more in length on the contacting surface of the actuator and the bearing holder.
2. Inspect the friction surface of the actuator and the bearing holder with the straightedge, and determine if a 0.30 mm (0.0118 in.) feeler gauge will fit on the part of wear.
3. If it will fit, resurface.

Flatness of actuator and bearing holder	Allowable limit	0.30 mm 0.012 in.
---	-----------------	----------------------

9Y1210855TXS0071US0



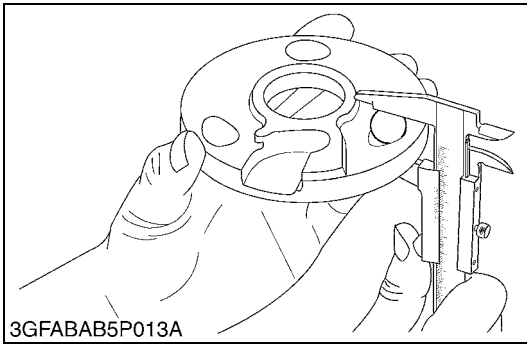

**Height of Cam Plate and Ball**

1. Measure the height of the cam plate with the ball installed.
2. If the measurement is less than the allowable limit, replace the cam plate and balls.
3. Inspect the ball holes of cam plate for uneven wear.
4. If the uneven wear is found, replace it.

Height of cam plate and ball	Factory specification	22.89 to 22.99 mm 0.9012 to 0.9051 in.
	Allowable limit	22.40 mm 0.8819 in.

9Y1210855TXS0072US0

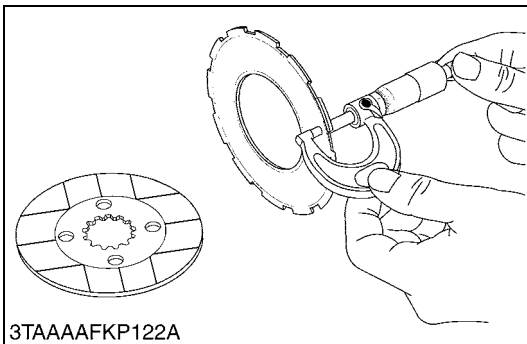

**Brake Disc and Friction Plate Wear**

1. Measure the brake disc thickness and the friction plate thickness with an outside micrometer.
2. If the thickness is less than the allowable limit, replace it.

Brake disc thickness	Factory specification	3.30 to 3.50 mm 0.130 to 0.137 in.
	Allowable limit	3.0 mm 0.12 in.

Friction plate thickness	Factory specification	1.92 to 2.08 mm 0.0756 to 0.0818 in.
	Allowable limit	1.52 mm 0.0598 in.

9Y1210855TXS0073US0

# **3 FRONT AXLE**

# MECHANISM

## CONTENTS

1. STRUCTURE.....	3-M1
2. FRONT WHEEL ALIGNMENT.....	3-M2

# 1. STRUCTURE

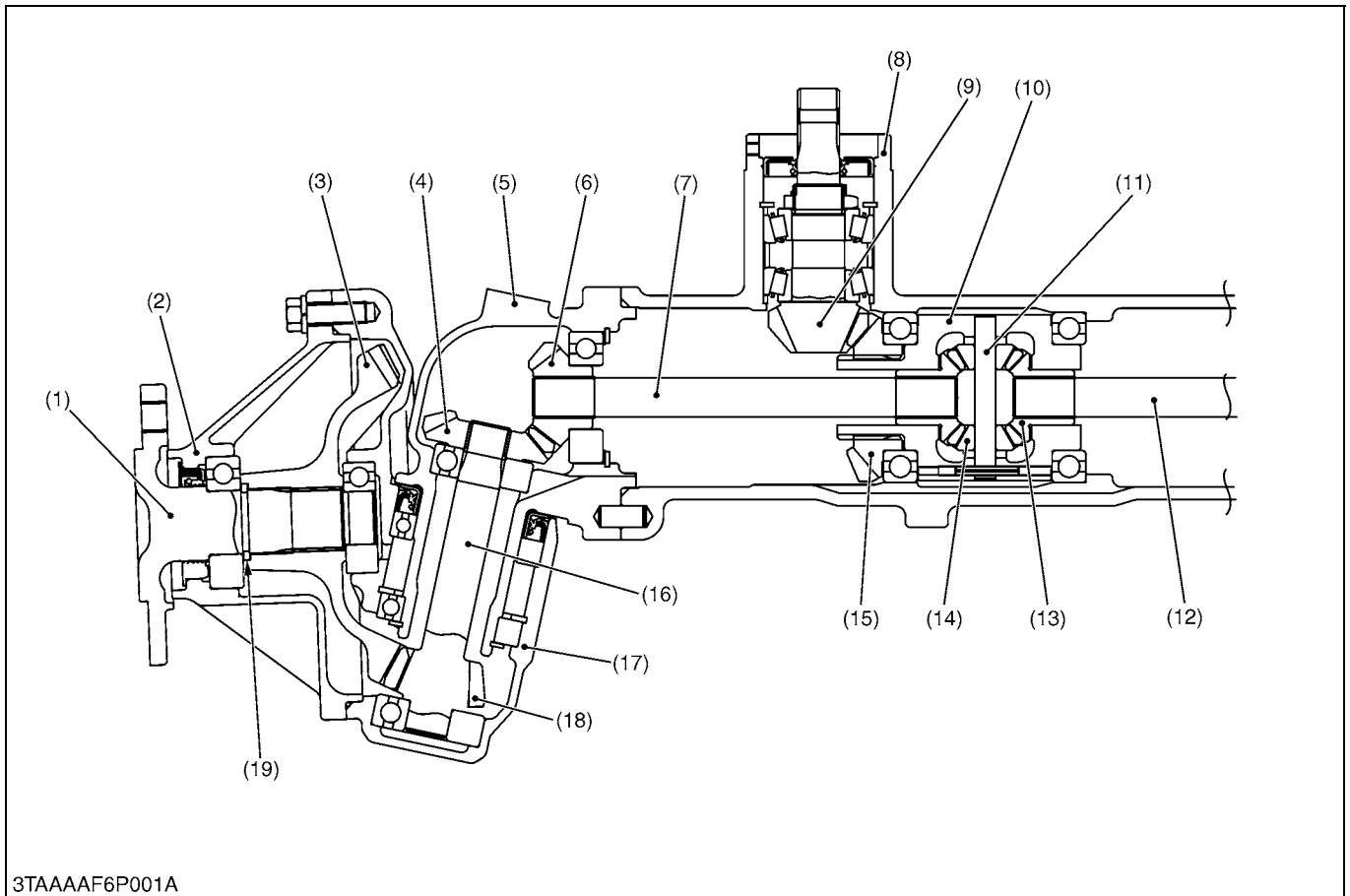

3TAAAF6P001A

- |                     |                                 |                                  |                       |
|---------------------|---------------------------------|----------------------------------|-----------------------|
| (1) Axle            | (6) Bevel Gear                  | (11) Differential Pinion Shaft   | (16) Bevel Gear Shaft |
| (2) Axle Flange     | (7) Differential Yoke Shaft, RH | (12) Differential Yoke Shaft, LH | (17) Front Gear Case  |
| (3) Bevel Gear      | (8) Front Axle Case             | (13) Differential Side Gear      | (18) Bevel Gear       |
| (4) Bevel Gear      | (9) Bevel Pinion Shaft          | (14) Differential Pinion Gear    | (19) Collar           |
| (5) Bevel Gear Case | (10) Differential Gear Assembly | (15) Bevel Gear                  |                       |

The front axle of the 4WD is constructed as shown above. Power is transmitted from the transmission through the propeller shaft to the bevel pinion shaft (9), then to the bevel gear (15) and to the differential side gear (13).

The power through the differential side gear is transmitted to the differential yoke shaft (7), (12), and to the bevel gear shaft (16) through the bevel gears (4), (6) in the bevel gear case (5).

The revolution is greatly reduced by the bevel gears (18), (3), then the power is transmitted to the axle (1).

The differential system allows each wheel to rotate at a different speed to make turning easier.

9Y1210855FBM0001US0

## 2. FRONT WHEEL ALIGNMENT

To assure smooth mobility or maneuverability and enhance stable and straight running, the front wheels are mounted at an angle to the right, left and forward directions. This arrangement is referred to as the Front Wheel Alignment.

9Y1210855FBM0002US0

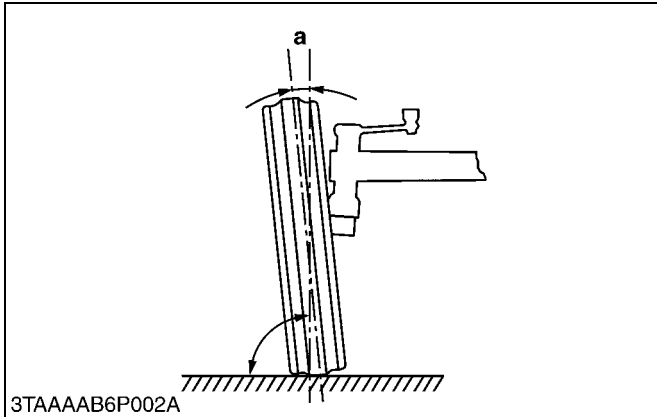

### Camber

The front wheels are tilted from the vertical as viewed from the front, upper wheels are spreader than lower ones.

This inclination is called camber "a". Camber reduces bending or twisting of the front axle caused by vertical load or running resistance, and also keeps the stability in running.

Camber	0.035 rad 2°
--------	-----------------

9Y1210855FBM0003US0

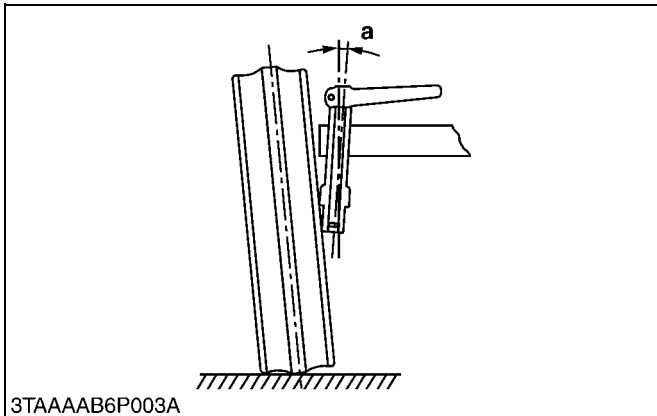

### Kingpin Angle

The Kingpin is titled from the vertical as viewed from the front.

This angle is called kingpin angle "a". As with the camber, kingpin angle reduces rolling resistance of the wheels, and prevents any shimmy motion of the steering wheel.

It also reduces steering effort.

Kingpin Angle	0.209 rad 12°
---------------	------------------

9Y1210855FBM0004US0

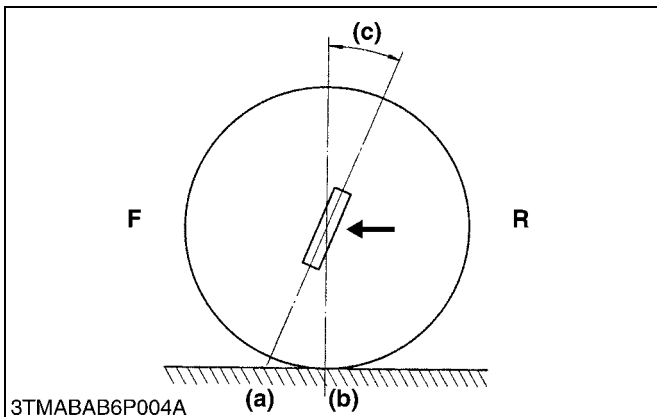

### Caster

The kingpin is titled forward as viewed from the side.

The point (b) of the wheel center line is behind the point (a) of the kingpin shaft center line.

This inclination is called caster (c). Caster helps provide steering stability.

As with the kingpin inclination, caster reduces steering effort.

Caster	0 rad 0°
--------	-------------

F: Front

R: Rear

9Y1210855FBM0005US0

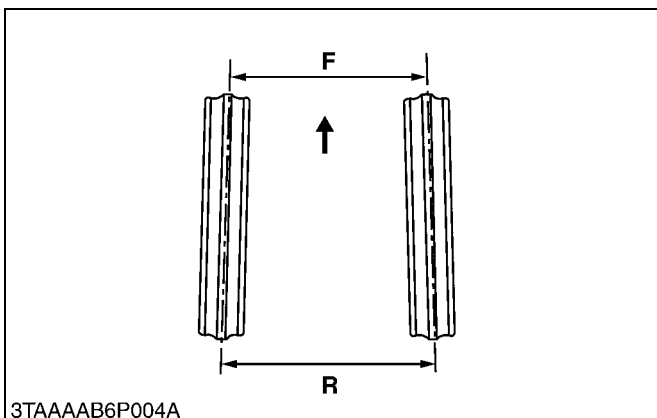

### Toe-in

Viewing the front wheels from above reveals that the distance between the toes of the front wheels is smaller than that between the heels.

It is called toe-in. The front wheels tend to roll outward due to the camber, but toe-in offsets it and ensures parallel rolling of the front wheels. Another purpose of toe-in is to prevent excessive and uneven wear of tires.

Toe-in	0 to 5 mm 0 to 0.19 in.
--------	----------------------------

F: Front

R: Rear

9Y1210855FBM0006US0

# SERVICING

## CONTENTS

1. TROUBLESHOOTING.....	3-S1
2. SERVICING SPECIFICATIONS.....	3-S2
3. TIGHTENING TORQUES.....	3-S3
4. CHECKING, DISASSEMBLING AND SERVICING.....	3-S4
[1] CHECKING AND ADJUSTING.....	3-S4
[2] PREPARATION.....	3-S5
(1) Separating Front Axle Assembly.....	3-S5
[3] DISASSEMBLING AND ASSEMBLING.....	3-S8
(1) Front Axle Assembly.....	3-S8
[4] SERVICING.....	3-S12

# 1. TROUBLESHOOTING

Symptom	Probable Cause	Solution	Reference Page
<b>Front Wheels Wander to Right or Left</b>	Tire pressure uneven	Adjust	G-64
	Improper toe-in adjustment (improper alignment)	Adjust	3-S4
	Clearance between center pin and pin support bushing excessive	Replace	3-S14
	Front axle rocking force too small	Adjust	3-S4
	Tie-rod end loose	Tighten	4-S8
	Air sucked in power steering circuit	Bleed	–
<b>Front Wheels Can Not Be Driven</b>	Front wheel driving gears in front axle gear case broken	Replace	3-S11
	Universal joint broken	Replace	3-S7
	Front wheel drive gears in transmission broken	Replace	–
	Front differential gear broken	Replace	3-S11
<b>Noise</b>	Gear backlash excessive	Adjust or replace	3-S12, 3-S13
	Oil insufficient	Fill	3-S5
	Bearings damaged or broken	Replace	–
	Gears damaged or broken	Replace	–
	Spiral bevel pinion shaft turning force improper	Adjust	3-S13

9Y1210855FBS0001US0

## 2. SERVICING SPECIFICATIONS

Item		Factory Specification	Allowable Limit
Front Wheel Alignment	Toe-in	0 to 5 mm 0 to 0.2 in.	–
Front Axle	Rocking Force	49.1 to 117 N 5.00 to 12.0 kgf 11.1 to 26.4 lbf	–
Differential Case to Differential Side Gear	Clearance	0.040 to 0.082 mm 0.0016 to 0.0032 in.	0.17 mm 0.0067 in.
• Differential Case	I.D.	26.000 to 26.021 mm 1.0237 to 1.0244 in.	–
• Differential Side Gear	O.D.	25.939 to 25.960 mm 1.0213 to 1.0220 in.	–
Differential Pinion Shaft to Differential Pinion	Clearance	0.025 to 0.055 mm 0.0009 to 0.0021 in.	0.25 mm 0.0098 in.
• Differential Pinion Shaft	I.D.	9.960 to 9.975 mm 0.3922 to 0.3927 in.	–
• Differential Pinion	O.D.	10.000 to 10.015 mm 0.39370 to 0.39429 in.	–
Differential Pinion to Differential Side Gear	Backlash	0.1 to 0.3 mm 0.004 to 0.01 in.	–
Bevel Pinion Shaft	Turning Torque	0.80 to 1.0 N·m 0.082 to 0.10 kgf·m 0.59 to 0.73 lbf·ft	–
Bevel Pinion Shaft to Bevel Gear	Backlash	0.1 to 0.3 mm 0.004 to 0.01 in.	–
12T Bevel Gear to 15T Bevel Gear	Backlash	0.1 to 0.3 mm 0.004 to 0.01 in.	–
Center Pin to Pin Support Bushing	Clearance	0 to 0.231 mm 0 to 0.00909 in.	0.70 mm 0.028 in.
• Center Pin	I.D.	19.850 to 20.000 mm 0.78150 to 0.78740 in.	–
• Bushing	O.D.	20.000 to 20.081 mm 0.78741 to 0.79059 in.	–

9Y1210855FBS0002US0



### 3. TIGHTENING TORQUES

Tightening torques of screws, bolts and nuts on the table below are especially specified.  
 (For general use screws, bolts and nuts: Refer to "5. TIGHTENING TORQUES" on page G-13.)

Item	N·m	kgf·m	lbf·ft
Front wheel mounting screw	149 to 179	15.2 to 18.3	110 to 132
Tie-rod slotted nut	18 to 34	1.8 to 3.5	13 to 25
Power steering cylinder mounting screw	48 to 55	4.9 to 5.7	36 to 41
Power steering hose	24 to 27	2.4 to 2.8	18 to 20
Bevel gear case mounting screw (M10)	48 to 55	4.9 to 5.7	36 to 41
Bevel gear case mounting screw (M12)	78 to 90	7.9 to 9.2	58 to 66
Front gear case cover mounting screw	48 to 55	4.9 to 5.7	36 to 41

9Y1210855FBS0003US0

# 4. CHECKING, DISASSEMBLING AND SERVICING

## [1] CHECKING AND ADJUSTING

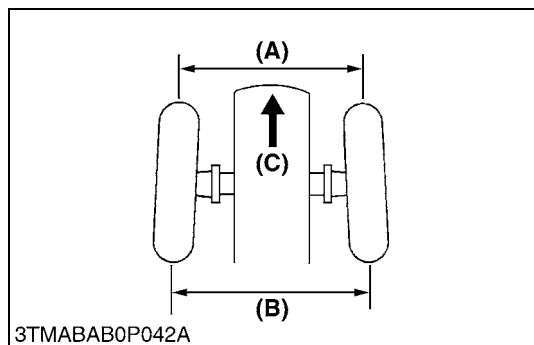

### Toe-in

1. Inflate the tires to the specified pressure.
2. Turn the front wheels straight ahead.
3. Measure the toe-in ((B) - (A)).
4. If the measurement is not within the factory specifications, adjust the tie-rod length.

Toe-in ((B) - (A))	Factory specification	0 to 5 mm 0 to 0.2 in.
--------------------	-----------------------	---------------------------

### ■ Adjusting procedure

1. Loosen the lock nuts and turn the tie-rod to adjust the rod length until the proper toe-in measurement is obtained.
2. Retighten the lock nuts.

- (1) Tie-rod
- (2) Lock Nut
- (A) Wheel to Wheel Distance at Front
- (B) Wheel to Wheel Distance at Rear
- (C) Front

9Y1210855FBS0004US0

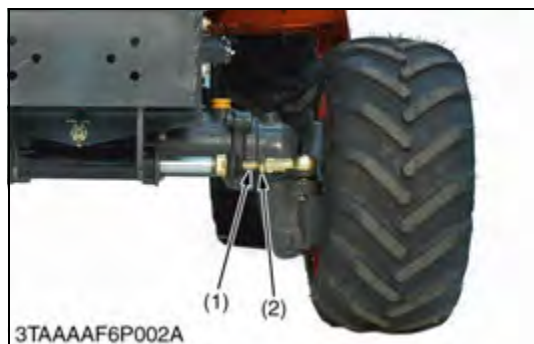

### Front Axle Rocking Force

1. Jack up the front side of tractor and remove the front wheel.
2. Set a spring balance to the front gear case cover.
3. Measure the front axle rocking force.
4. If the measurement is not within the factory specifications, adjust as following.

### ■ Adjusting procedure

1. Remove the cotter pin (1).
2. Tighten or loosen the adjusting nut (2) so that the measurement of rocking force comes to factory specifications.
3. If the slot and pin hole do not meet, align the nut until they do meet within factory specifications.
4. Install the new cotter pin.

### (When reassembling)

- Be sure to split the cotter pin like an anchor.

### (Reference)

- Tightening torque of adjusting nut:  
20 N·m (2.0 kgf·m, 14 lbf·ft)

Front axle rocking force	Factory specification	49.1 to 117 N 5.00 to 12.0 kgf 11.1 to 26.4 lbf
--------------------------	-----------------------	---

- (1) Cotter Pin
- (2) Adjusting Nut

9Y1210855FBS0005US0



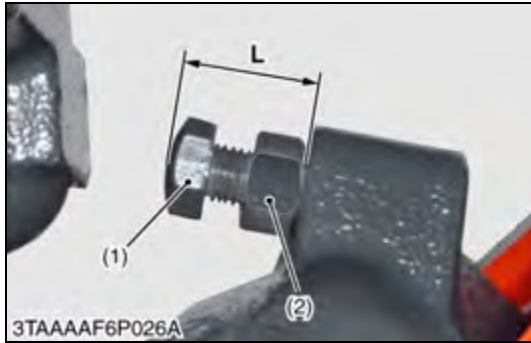

**Front Wheel Steering Angle**

1. Inflate the tires to the specified pressure.
2. Loosen the lock nut and shorten the length of stopper bolt LH (1).
3. Steer the wheels to the extreme left.
4. Lengthen the length of stopper bolt (1) until the stopper bolt contacts with the bevel gear case (3).
5. Return the steering wheel to straight ahead and lengthen the stopper bolt 1/2 turns from above position further.
6. Lock the stopper bolt by lock nut (2).
7. For adjusting the right steering angle, perform the same procedure as mentioned in left steering angle.

**(Reference)**

Steering angle	Right side	0.84 to 0.87 rad 48 to 50 °
	Left side	0.93 to 0.95 rad 53 to 55 °

Length of adjusting bolt "L"	BX1870D	Right side	22 mm 0.87 in.
		Left side	19 mm 0.75 in.
	BX2370D and BX2670D	Right side	23 mm 0.91 in.
		Left side	16 mm 0.63 in.

- (1) Stopper Bolt LH
- (2) Lock Nut

- (3) Bevel Gear Case

9Y1210855FBS0006US0

**[2] PREPARATION**

**(1) Separating Front Axle Assembly**

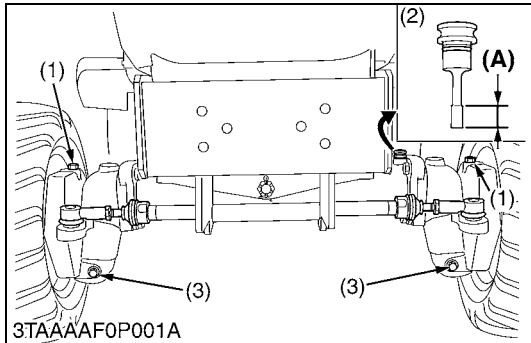

**Draining Front Axle Case Oil**

1. Place the oil pans underneath the front axle case.
2. Remove both right and left hand side drain plugs (3) and filling plug (2) to drain the oil.
3. After draining, reinstall the drain plugs (3).

**(When reassembling)**

- When re-filling, remove the right and left breather plugs (1).

**■ IMPORTANT**

- **After ten minutes, check the oil level again, add oil to prescribed level.**
- **Use KUBOTA SUPER UDT fluid or SAE80, 90 gear oil. Refer to "4. LUBRICANTS, FUEL AND COOLANT" on page G-9.**

Front axle case oil	Capacity	BX1870D	2.3 L 2.4 U.S.qts 2.0 Imp.qts
		BX2370D and BX2670D	4.7 L 5.0 U.S.qts 4.1 Imp.qts

- (1) Breather Plug
- (2) Filling Plug with Dipstick
- (3) Drain Plug

**(A) Oil level is acceptable within this range.**

9Y1210855FBS0007US0



**Battery**

**⚠ CAUTION**

- When disconnecting the battery cables, disconnect the negative cable from the battery first. When connecting, connect the positive cable to the battery first.

1. Remove the under panel (1).
2. Disconnect the negative cable (3) from the battery.

- (1) Under Panel
- (2) Battery
- (3) Negative Cable

9Y1210855FBS0008US0



**Bonnet and Under Cover**

1. Open the bonnet (1), disconnect the connectors (3) for the head lights, then remove the bonnet with the bonnet bracket (4).
2. Remove the under cover (2).

- (1) Bonnet
- (2) Under Cover
- (3) Connector
- (4) Bonnet Bracket

9Y1210855FBS0009US0



**Front Wheel and Propeller Shaft Cover**

1. Lift up the front of tractor and place the disassembling stand under the front axle frame.
2. Remove the front wheels.
3. Remove the propeller shaft cover mounting bolt and slide the propeller shaft cover (1).

**(When reassembling)**



Tightening torque	Front wheel mounting screw	149 to 179 N·m 15.2 to 18.3 kgf·m 110 to 132 lbf·ft
-------------------	----------------------------	---

- (1) Propeller Shaft Cover

9Y1210855FBS0010US0

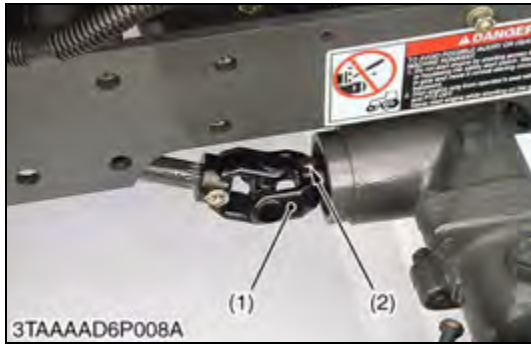

**Disconnecting Propeller Shaft**

1. Tap out the spring pins (2) and disconnect the universal joint (1) and spiral bevel pinion shaft.

**(When reassembling)**

- Apply grease to the splines of the propeller shaft and universal joint.

- (1) Universal Joint (2) Spring Pin

9Y1210855FBS0011US0



**Front Axle Assembly**

1. Remove the power steering hose clamp (1).
2. Place the garage jack under the front axle.
3. Remove the cotter pin (3).
4. Remove the slotted nut (2) of center pin and separate the front axle from the frame.
5. Disconnect the power steering hoses (4).

**(When reassembling)**

- After mounting the front axle assembly to the frame, be sure to adjust the front axle rocking force. (See page 3-S4.)
- Installing the cotter pin, be sure to split the cotter pin like an anchor.

Tightening torque	Power steering hose	24 to 27 N·m 2.4 to 2.8 kgf·m 18 to 20 lbf·ft
-------------------	---------------------	---



- (1) Hose Clamp (3) Cotter Pin  
 (2) Slotted Nut (Adjusting Nut for Front Axle Rocking Force) (4) Power Steering Hose

9Y1210855FBS0012US0





### [3] DISASSEMBLING AND ASSEMBLING

#### (1) Front Axle Assembly

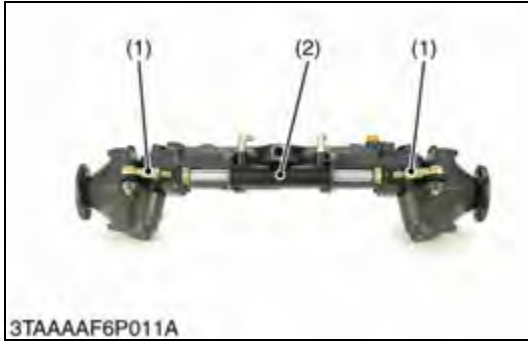

#### Power Steering Cylinder

1. Remove the cotter pin and remove the slotted nut for tie-rod (1).
2. Remove the power steering cylinder mounting screws and remove the power steering cylinder (2) with tie-rod.

#### **(When reassembling)**

#### ■ NOTE

- Tighten the slotted nut to 18 N·m (1.8 kgf·m, 13 lbf·ft). If the slot and pin hole do not meet, tighten the nut until they do meet, and install the cotter pin.
- Be sure to split the cotter pin like an anchor.

Tightening torque	Tie-rod slotted nut	18 to 34 N·m 1.8 to 3.5 kgf·m 13 to 25 lbf·ft
	Power steering cylinder mounting screw	48 to 55 N·m 4.9 to 5.7 kgf·m 36 to 41 lbf·ft

(1) Tie-rod

(2) Power Steering Cylinder

9Y1210855FBS0013US0

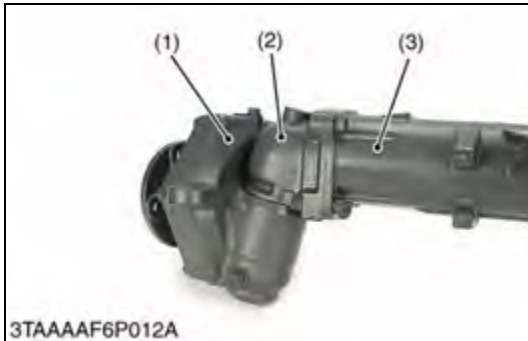

#### Bevel Gear Case and Front Gear Case

1. Remove the bevel gear case mounting screws.
2. Remove the bevel gear case (2) and front gear case (1) as a unit from the front axle case (3).

#### **(When reassembling)**

- Apply grease to the O-ring and be careful not to damage it.
- Do not interchange right and left bevel gear case assemblies and right and left gear case assemblies.

Tightening torque	Bevel gear case mounting screw (M10)	48 to 55 N·m 4.9 to 5.7 kgf·m 36 to 41 lbf·ft
	Bevel gear case mounting screw (M12)	78 to 90 N·m 7.9 to 9.2 kgf·m 58 to 66 lbf·ft

(1) Front Gear Case

(3) Front Axle Case

(2) Bevel Gear Case

9Y1210855FBS0014US0



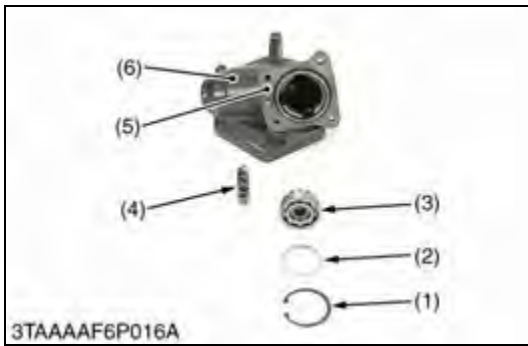

**Front Gear Case and Bevel Gear Case**

1. Remove the internal snap ring (1).
2. Remove the bevel gear with ball bearing (3) and shim (2).
3. Remove the bevel gear (4).
4. Remove the external snap ring (7).
5. Remove the bevel gear case (5) from front gear case (6).
6. Remove the oil seal (12) and the ball bearing (11).
7. Remove the internal snap ring (10) and remove the ball bearing (9).
8. Remove the bevel gear shaft (8) with ball bearing.

**(When reassembling)**

- Install the oil seal (12) of bevel gear case, noting its direction as shown in the figure.
- Install the adjusting shims (2) to their original position.



- |                        |                         |
|------------------------|-------------------------|
| (1) Internal Snap Ring | (8) Bevel Gear Shaft    |
| (2) Shim               | (9) Ball Bearing        |
| (3) Ball Bearing       | (10) Internal Snap Ring |
| (4) Bevel Gear         | (11) Ball Bearing       |
| (5) Bevel Gear Case    | (12) Oil Seal           |
| (6) Front Gear Case    | (13) Ball Bearing       |
| (7) External Snap Ring |                         |

9Y1210855FBS0017US0

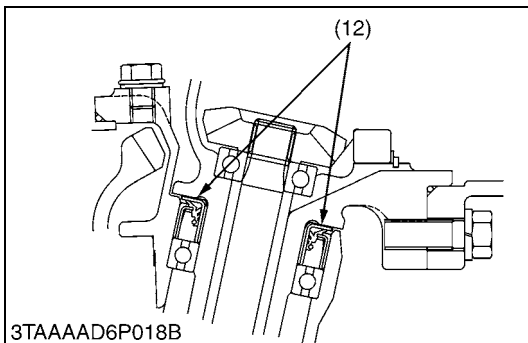
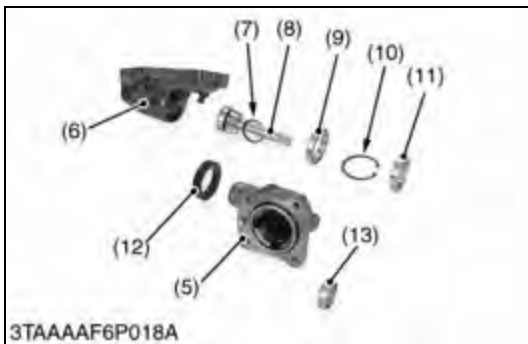



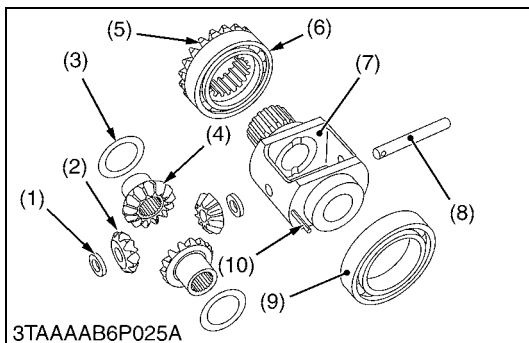
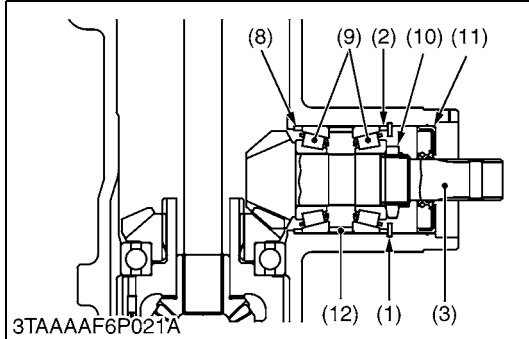
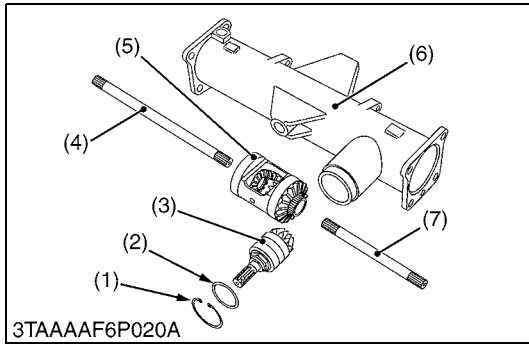

### Bevel Pinion Shaft and Differential Gear Assembly

1. Remove the differential yoke shaft (4), (7).
2. Remove the oil seal (11).
3. Remove the internal snap ring (1).
4. Pull out the bevel pinion shaft (3).
5. Remove the differential gear assembly (5), from right side of front axle case (6).
6. Remove the stake of lock nut (10), and then remove the lock nut (10).
7. Remove the taper roller bearing (9).

#### (When reassembling)

- Apply gear oil to the taper roller bearings (9) and install them correctly, noting their direction.
- Replace the lock nut (10) and oil seal (11) with new ones.
- After tighten the lock nut (10) to the specified torque, stake it firmly.
- Install the adjusting collars (2), (8) to their original position.

- |                                |                                |
|--------------------------------|--------------------------------|
| (1) Internal Snap Ring         | (7) Differential Yoke Shaft RH |
| (2) Adjusting Collar           | (8) Adjusting Collar           |
| (3) Bevel Pinion Shaft         | (9) Taper Roller Bearing       |
| (4) Differential Yoke Shaft LH | (10) Lock Nut                  |
| (5) Differential Gear Assembly | (11) Oil Seal                  |
| (6) Front Axle Case            | (12) Collar                    |

9Y1210855FBS0018US0

### Differential Gear

1. Remove the bevel gear (5) with bearing (6) and bearing (9) by puller.
2. Remove the spring pin (10).
3. Remove the differential pinion shaft (8).
4. Remove the differential pinions (2), differential side gears (4) and shims (1), (3).

#### ■ NOTE

- Arrange the parts to know their original position.

#### (When reassembling)

- Apply molybdenum disulfide (Three Bond 1901 or equivalent) to the inner circumferential surface of the differential side gears, differential pinions and shims.

- |                            |                               |
|----------------------------|-------------------------------|
| (1) Shim                   | (6) Bearing                   |
| (2) Differential Pinion    | (7) Differential Gear Case    |
| (3) Shim                   | (8) Differential Pinion Shaft |
| (4) Differential Side Gear | (9) Ball Bearing              |
| (5) Bevel Gear             | (10) Spring Pin               |

9Y1210855FBS0019US0

## [4] SERVICING



3TAAAD6P023A

### Clearance between Differential Case and Differential Side Gear

1. Measure the differential side gear boss O.D..
2. Measure the differential case bore I.D., and calculate the clearance.
3. Measure the differential case cover bore I.D., and calculate the clearance.
4. If the clearance exceeds the allowable limit, replace faulty parts.

Clearance between differential case and differential side gear	Factory specification	0.040 to 0.082 mm 0.0016 to 0.0032 in.
	Allowable limit	0.17 mm 0.0067 in.

Differential case bore I.D.	Factory specification	26.000 to 26.021 mm 1.0237 to 1.0244 in.
Differential side gear O.D.	Factory specification	25.939 to 25.960 mm 1.0213 to 1.0220 in.

9Y1210855FBS0020US0



3TAAAD6P024A

### Clearance between Differential Pinion Shaft and Differential Pinion

1. Measure the differential pinion shaft O.D..
2. Measure the differential pinion I.D., and calculate the clearance.
3. If the clearance exceeds the allowable limit, replace faulty parts.

Clearance between differential pinion shaft and differential pinion	Factory specification	0.025 to 0.055 mm 0.00099 to 0.0021 in.
	Allowable limit	0.25 mm 0.0098 in.

Differential pinion shaft O.D.	Factory specification	9.960 to 9.975 mm 0.3922 to 0.3927 in.
Differential pinion I.D.	Factory specification	10.000 to 10.015 mm 0.39370 to 0.39429 in.

9Y1210855FBS0021US0



3TAAAD6P025A

### Backlash between Differential Pinion and Differential Side Gear

1. Set a dial gauge (lever type) on a tooth of the differential pinion.
2. Fix the differential side gear, and move the differential pinion to measure the backlash.
3. If the measurement exceeds the factory specifications, adjust with the differential side gears shims.

Backlash between differential pinion and differential side gear	Factory specification	0.1 to 0.3 mm 0.004 to 0.01 in.
---	-----------------------	------------------------------------

### **(Reference)**

- Thickness of adjusting shims:
  - For side gear:
    - 0.80 mm (0.031 in.)
    - 1.0 mm (0.039 in.)
    - 1.2 mm (0.047 in.)
  - For pinion:
    - 3.30 mm (0.130 in.)
    - 3.50 mm (0.138 in.)
    - 3.70 mm (0.146 in.)
    - 3.90 mm (0.154 in.)

9Y1210855FBS0022US0

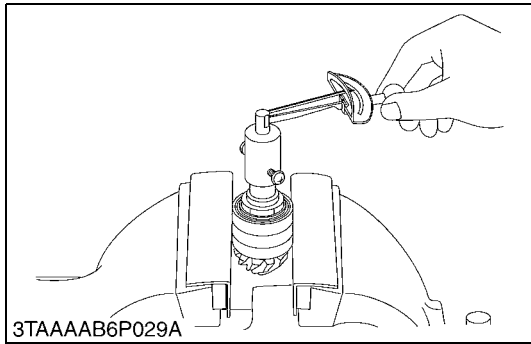

**Turning Torque of Bevel Pinion Shaft**

1. Clamp the spiral bevel pinion shaft assembly to the vise and tighten the staking nut.
2. Measure the turning torque of bevel pinion shaft.
3. If the turning torque is not within the factory specifications, adjust with the lock nut.

Turning torque	Factory specification	0.80 to 1.0 N·m 0.082 to 0.10 kgf·m 0.59 to 0.73 lbf·ft
----------------	-----------------------	---

**NOTE**

- After turning force adjustment, be sure to stake the lock nut.

9Y1210855FBS0023US0



**Backlash between Bevel Pinion Shaft and Bevel Gear**

1. Put the wire of solder (0.5 mm (0.02 in.) thickness) or plastigauge on the position where the tooth proper contact of bevel pinion shaft.
2. Fix the bevel gear and rotate the bevel pinion shaft carefully.
3. Measure the backlash.
4. If the backlash is not within the factory specifications, change the adjusting collar (3) and (4). For example change the adjusting collar (4) to 0.1 mm (0.004 in.) smaller size, and change the adjusting collar (3) to 0.1 mm (0.004 in.) larger size.
5. Adjust the backlash properly by repeating the above procedures.

Backlash between bevel pinion shaft and bevel gear	Factory specification	0.1 to 0.3 mm 0.004 to 0.01 in.
--	-----------------------	------------------------------------

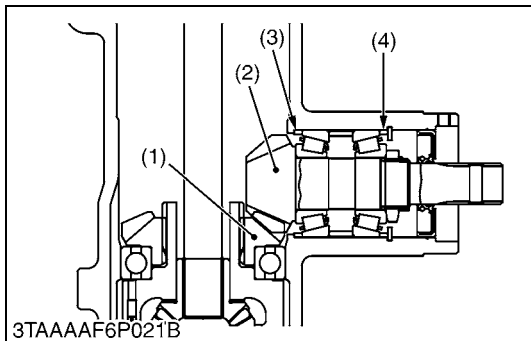

**(Reference)**

- Thickness of adjusting collars (3), (4):
  - 3.40 mm (0.134 in.)
  - 3.60 mm (0.142 in.)
  - 3.80 mm (0.150 in.)
  - 3.90 mm (0.154 in.)
  - 4.00 mm (0.157 in.)
  - 4.10 mm (0.161 in.)
  - 4.20 mm (0.165 in.)
  - 4.40 mm (0.173 in.)
  - 4.50 mm (0.177 in.)
  - 4.60 mm (0.181 in.)

- (1) Bevel Gear
- (2) Bevel Pinion Shaft
- (3) Adjusting Collar
- (4) Adjusting Collar

9Y1210855FBS0024US0

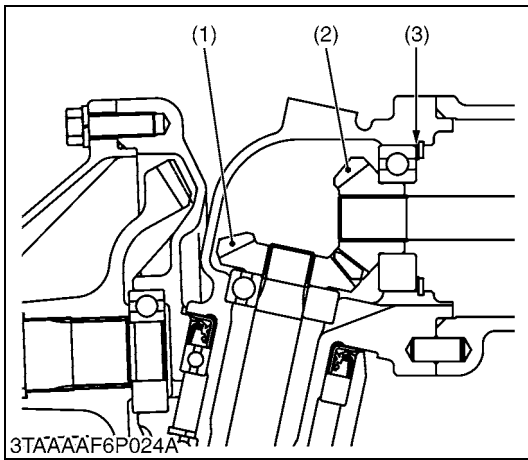

**Backlash between 12T Bevel Gear and 15T Bevel Gear**

1. Stick a strip of wire of solder or plastigauge to three spots on the 15T bevel gear (1) with grease.
2. Fix the front axle case, bevel gear case and front gear case.
3. Turn the axle.
4. Remove the bevel gear case from front axle case and measure the backlash.
5. If the backlash is not within the factory specifications, adjust with shim (3).

Backlash between 12T bevel gear and 15T bevel gear	Factory specification	0.1 to 0.3 mm 0.004 to 0.01 in.
--	-----------------------	------------------------------------

**(Reference)**

- Thickness of adjusting shims (3):  
0.8 mm (0.03 in.)  
1.0 mm (0.039 in.)  
1.2 mm (0.047 in.)  
1.4 mm (0.055 in.)
- Tooth contact:  
More than 35 %

- (1) 15T Bevel Gear  
(2) 12T Bevel Gear

(3) Shim

9Y1210855FBS0025US0



**Clearance between Center Pin and Pin Support Bushing**

1. Measure the center pin O.D. with an outside micrometer.
2. Measure the pin support bush I.D. of the front axle with a cylinder gauge.
3. If the clearance exceeds the allowable limit, replace it.

Clearance between center pin and pin support bush	Factory specification	0 to 0.231 mm 0 to 0.00909 in.
	Allowable limit	0.70 mm 0.028 in.

Center pin O.D.	Factory specification	19.850 to 20.000 mm 0.78150 to 0.78740 in.
Bush I.D.	Factory specification	20.000 to 20.081 mm 0.78741 to 0.79059 in.

9Y1210855FBS0026US0

# 4 STEERING

# MECHANISM

## CONTENTS

1. HYDRAULIC CIRCUIT .....	4-M1
2. STEERING CONTROLLER.....	4-M2
3. STEERING CYLINDER .....	4-M3

# 1. HYDRAULIC CIRCUIT

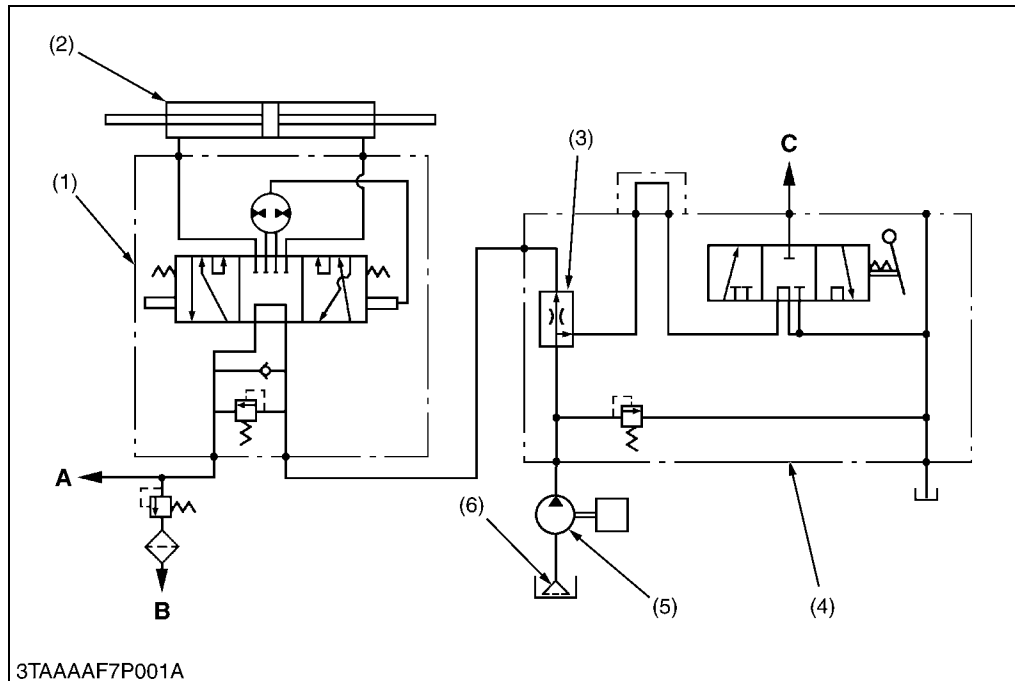

- (1) Steering Controller
  - (2) Steering Cylinder
  - (3) Flow Priority Valve
  - (4) Hydraulic Control Valve Assembly
  - (5) Hydraulic Pump
  - (6) Oil Strainer
- A: To PTO Clutch Valve  
 B: To HST  
 C: To Hydraulic Cylinder

3TAAAF7P001A

This model is provided with a full hydrostatic power steering.

In the full hydrostatic power steering, the steering controller is connected to the steering cylinder with only the hydraulic piping. Accordingly, it does not have mechanical transmitting parts such as steering gear, pitman arm, drag link, etc.. Therefore, it is simple in construction. This steering system consists of the oil strainer (6), hydraulic pump (5), flow priority valve (3), steering controller (1), steering cylinder (2), etc..

Flow priority valve (3) which located in the hydraulic control valve assembly (4) divides the oil into two direction. One is the control flow to power steering (constantly (8.0 L/min., 2.1 U.S.gals/min., 1.8 Imp.gals/min.)), and the other is excessive flow to control valve of implement lift control.

By operating the power steering body, the required amount of oil is fed to the steering cylinder (2).

9Y1210855STM0001US0

## 2. STEERING CONTROLLER

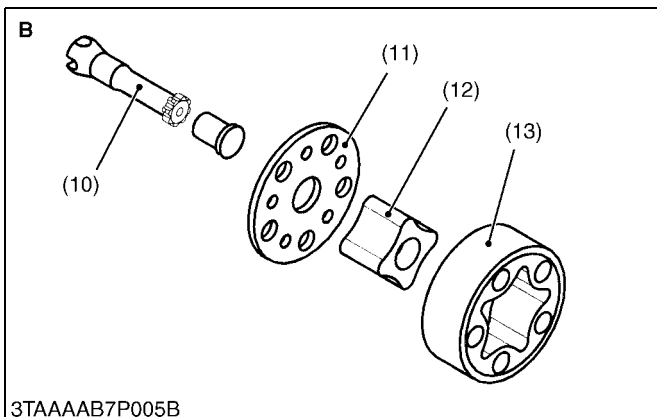
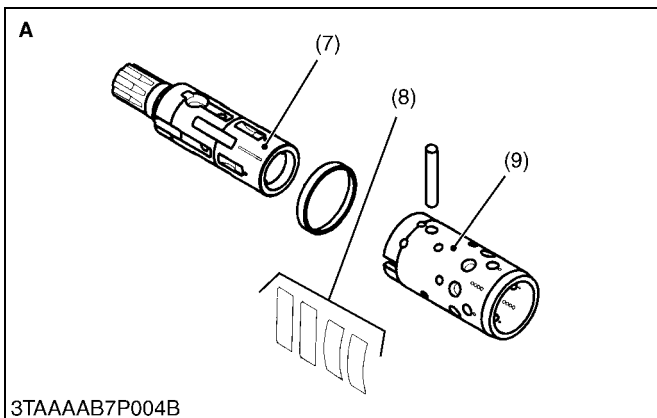
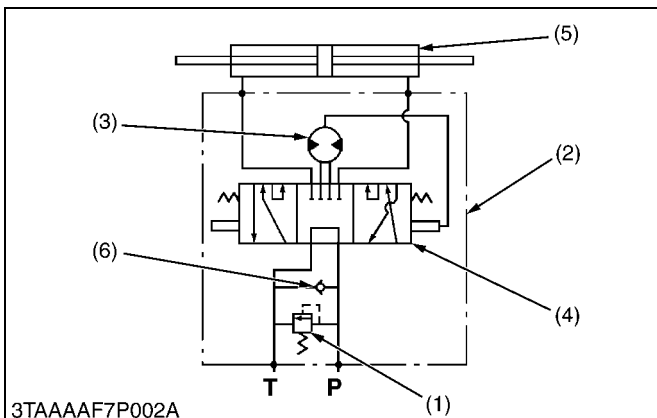
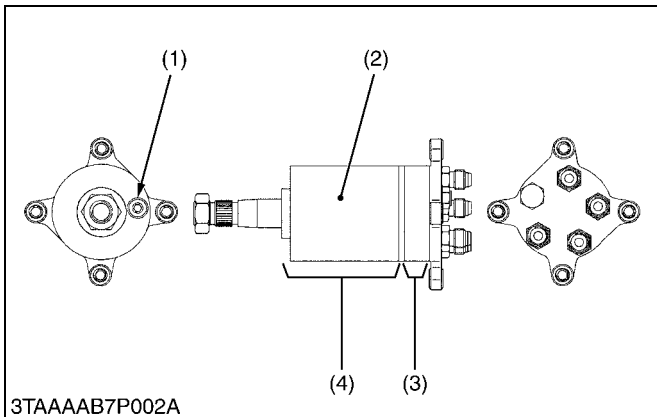

The steering controller consists of a control valve (4) and a metering device (3).

### ■ Control Valve

The control valve is a rotating spool type.

When the steering wheel is not turned, the position of the spool (7) and sleeve (9) is kept neutral by the centering spring (8). This causes the forming of a "Neutral" oil circuit.

When the steering wheel is turned either clockwise or counterclockwise, the position of the spool and sleeve changes in relation to the centering spring. This allows the forming of a "Right Turning" or "Left Turning" oil circuit. At the same time, the gear pump (Metering device) rotates with the spool and sends the oil to the cylinder corresponding to the rotation of the steering wheel.

### ■ Metering Device

Oil sent from the hydraulic pump to the steering cylinder, passes through the metering device (3).

Namely, when the rotor is driven, two chambers suck in oil due to volumetric change in the pump chambers formed between the rotor (12) and the stator (13), while oil is discharged from other two chambers. On the other hand, rotation of the steering wheel is directly transmitted to the rotor through the spool (7), drive shaft (10), etc.

Accordingly, the metering device serves to supply the steering cylinder with oil, amount of which corresponds to the rotation of the steering wheel. The wheels are thus turned by the angle corresponding to the rotation of the steering wheel.

When the engine stops or the hydraulic pump malfunctions, the metering device functions as a manual trochoid pump, which makes manual steering possible.

### ■ Relief Valve

The relief valve (1) is located in the steering controller. It controls the maximum pressure of the power steering system.

Its setting pressure is as follows.

8.33 to 8.83 MPa

85 to 90 kgf/cm<sup>2</sup>

1209 to 1280 psi

- |                         |  |
|-------------------------|--|
| (1) Relief Valve        | (11) Distributor Plate                                 |
| (2) Steering Controller | (12) Rotor   |
| (3) Metering Device     | (13) Stator  |
| (4) Control Valve       |  |
| (5) Steering Cylinder   |  |
| (6) Check Valve         |  |
| (7) Spool               | <b>A: Control Valve</b>                                |
| (8) Centering Spring    | <b>B: Metering Device</b>                              |
| (9) Sleeve              | <b>P: P Port</b>                                       |
| (10) Drive Shaft        | <b>(From flow priority valve)</b>                      |
|                         | <b>T: T Port (To PTO clutch valve and HST circuit)</b> |

9Y1210855STM0002US0



### 3. STEERING CYLINDER

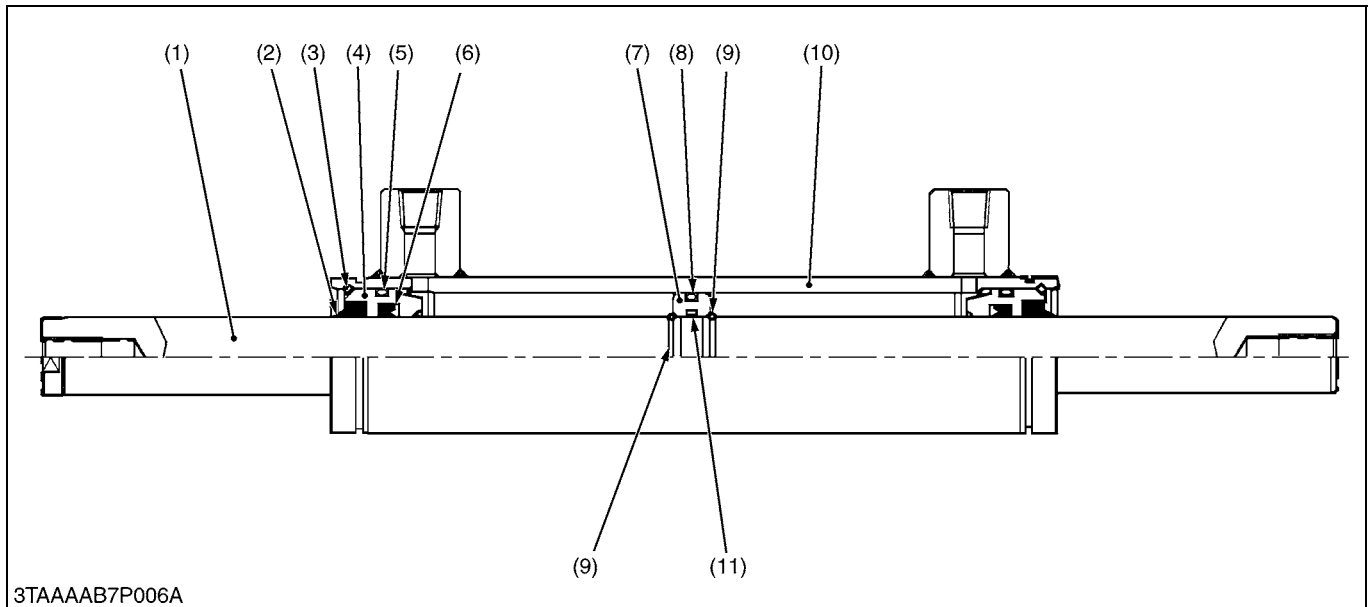

- |                        |               |                        |                    |
|------------------------|---------------|------------------------|--------------------|
| (1) Rod                | (4) Guide     | (7) Center Piston      | (10) Cylinder Tube |
| (2) Wiper Seal         | (5) O-ring    | (8) Piston O-ring      | (11) Rod O-ring    |
| (3) Internal Snap Ring | (6) Seal Ring | (9) External Snap Ring |                    |

The steering cylinder is single piston both rod double-acting type. This steering cylinder is installed parallel to the front axle and connected to tie-rods.

The tie-rods connected to both knuckle arm guarantees equal steering movement to both front wheels.

The steering cylinder provide force in both directions. Depending upon direction the steering wheel is turned pressure oil enters at one end of the cylinder to extend, or the other end to retract it, thereby turning front wheel of the tractor.

9Y1210855STM0003US0

# SERVICING

## CONTENTS

- 1. TROUBLESHOOTING.....4-S1
- 2. SERVICING SPECIFICATIONS .....4-S2
- 3. TIGHTENING TORQUES.....4-S3
- 4. CHECKING, DISASSEMBLING AND SERVICING .....4-S4
  - [1] CHECKING.....4-S4
    - (1) Relief Valve .....4-S4
  - [2] PREPARATION .....4-S4
    - (1) Separating Power Steering Controller .....4-S4
    - (2) Separating Power Steering Cylinder .....4-S6
  - [3] DISASSEMBLING AND ASSEMBLING .....4-S8
    - (1) Power Steering Cylinder .....4-S8
  - [4] SERVICING .....4-S9

# 1. TROUBLESHOOTING

Symptom	Probable Cause	Solution	Reference Page
<b>Cannot Be Steered</b>	Steering controller malfunctioning	Replace	4-S6
<b>Hard Steering</b>	Power steering oil improper (Transmission fluid)	Change with specified oil	G-9
	Hydraulic pump malfunctioning	Replace	5-S11
	Flow priority valve malfunctioning	Repair or replace	5-M6
	Steering controller malfunctioning	Replace	4-S6
<b>Steering Force Fluctuates</b>	Steering controller malfunctioning	Replace	4-S6
	Flow priority valve malfunctioning	Replace	5-M6
	Air sucked in pump due to lack of oil	Fill	G-32
	Air sucked in pump from suction circuit	Repair	–
<b>Steering Wheel Turns Spontaneously When Released</b>	Steering controller malfunctioning	Replace	4-S6
<b>Front Wheels Wander to Right and Left</b>	Steering controller malfunctioning	Replace	4-S6
	Air sucked in pump due to lack of oil	Fill	G-32
	Air sucked in pump from suction circuit	Repair	–
	Insufficient bleeding	Bleed	G-40
	Cylinder malfunctioning	Repair or replace	4-S8
	Improper toe-in adjustment	Adjust	3-S4
	Tire pressure uneven	Inflate	G-64
<b>Wheels Are Turned to a Direction Opposite to Steering Direction</b>	Cylinder piping connected in reverse	Repair	4-S6
<b>Steering Wheel Turns Idle in Manual Steering</b>	Insufficient bleeding	Bleed	G-40
	Air sucked in due to lack of oil	Fill	G-32
<b>Noise</b>	Air sucked in pump due to lack of oil	Fill	G-32
	Air sucked in pump from suction circuit	Repair	–
	Pipe deformed	Replace	–
<b>Oil Temperature Increases Rapidly</b>	Steering controller (relief valve) malfunctioning	Replace	4-S6

9Y1210855STS0001US0

## 2. SERVICING SPECIFICATIONS

### POWER STEERING BODY

Item		Factory Specification	Allowable Limit
Relief Valve	Operating Pressure	8.34 to 8.82 MPa 85.0 to 90.0 kgf/cm <sup>2</sup> 1210 to 1280 psi	–

### STEERING CYLINDER

Item		Factory Specification	Allowable Limit
Steering Cylinder	I.D.	40.000 to 40.062 mm 1.5748 to 1.5772 in.	40.100 mm 1.5787 in.
Piston Rod to Guide	Clearance	0.020 to 0.070 mm 0.00079 to 0.0027 in.	0.200 mm 0.00787 in.

9Y1210855STS0002US0

### 3. TIGHTENING TORQUES

Tightening torques of screws, bolts and nuts on the table below are especially specified.  
 (For general use screws, bolts and nuts: Refer to "5. TIGHTENING TORQUES" on page G-13.)

Item	N·m	kgf·m	lbf·ft
Steering wheel mounting nut	20 to 25	2.0 to 2.6	15 to 18
Power steering hose	24 to 27	2.4 to 2.8	18 to 20
Power steering cylinder mounting screw	48 to 55	4.9 to 5.7	36 to 41
Tie-rod slotted nut	18 to 34	1.8 to 3.5	13 to 25
Tie-rod screw	74 to 84	7.5 to 8.6	55 to 62

9Y1210855STS0003US0





**Steering Wheel**

1. Remove the steering wheel cap (1).
2. Remove the steering wheel mounting nut and remove the steering wheel.

**(When reassembling)**

Tightening torque	Steering wheel mounting nut	20 to 25 N·m 2.0 to 2.6 kgf·m 15 to 18 lbf·ft
-------------------	-----------------------------	---

(1) Steering Wheel Cap

9Y1210855STS0005US0



**Meter Panel**

1. Disconnect the main switch connector and combination switch connector (7).
2. Remove the hand accelerator lever grip and cruise control lever knob.
3. Disconnect the hand accelerator wire (3) and then turn the hand accelerator lever (2) to the operator seat side.
4. Open the bonnet, remove the panel mounting screws and dismount the meter panel.

- |                            |                                      |
|----------------------------|--------------------------------------|
| (1) Meter Panel            | (5) Main Switch                      |
| (2) Hand Accelerator Lever | (6) Combination Switch               |
| (3) Hand Accelerator Wire  | (7) Connector for Combination Switch |
| (4) Cruise Control Lever   |                                      |

9Y1210855STS0006US0



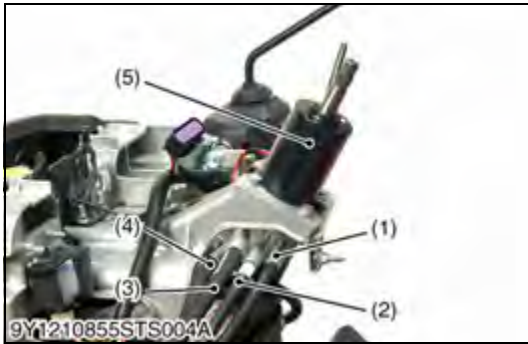

**Steering Controller**

1. Disconnect the power steering hoses (1), (2), (3), (4).
2. Remove the steering controller mounting screws and remove the steering controller (5).

**(When reassembling)**

- Be sure to connect the power steering hoses to their original position, and tighten them to the specified torque.

Tightening torque	Power steering hose	24 to 27 N·m 2.4 to 2.8 kgf·m 18 to 20 lbf·ft
-------------------	---------------------	---

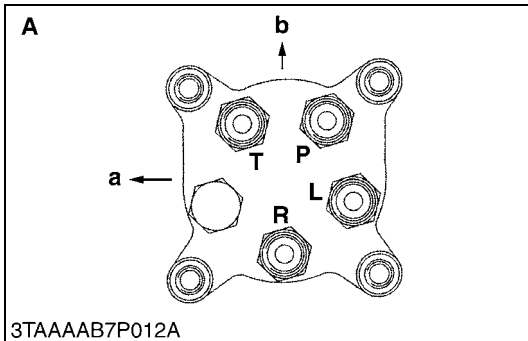

- (1) Cylinder Hose RH
- (2) Cylinder Hose LH
- (3) Delivery Hose
- (4) Return Hose
- (5) Steering Controller

- A: Bottom View**  
**P: Pump Port**  
**(Connect to Delivery Hose)**  
**T: Tank Port**  
**(Connect to Return Hose)**  
**L: L Port**  
**(Connect to Cylinder LH Hose)**  
**R: R Port**  
**(Connect to Cylinder RH Hose)**  
**a: Right**  
**b: Front**

9Y1210855STS0007US0

**(2) Separating Power Steering Cylinder**



**Bonnet and Under Cover**

1. Open the bonnet (1), and then loosen the knob bolts and pull forward to remove the under cover (2).
2. Disconnect the connectors (3) for head light and remove the bonnet bracket (4) with bonnet.

- (1) Bonnet
- (2) Under Cover
- (3) Connector
- (4) Bonnet Bracket

9Y1210855STS0008US0





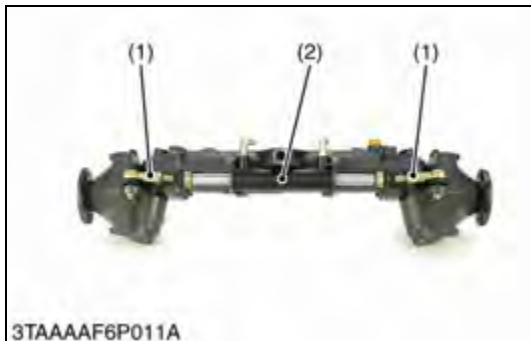

**Front Axle Assembly**

1. Remove the power steering hose clamp (1).
2. Place the garage jack under the front axle.
3. Remove the cotter pin (3).
4. Remove the slotted nut (2) of center pin and separate the front axle from the frame.
5. Disconnect the power steering hoses (4).

**(When reassembling)**

- After mounting the front axle assembly to the frame, be sure to adjust the front axle rocking force. (See page 3-S4.)
- Installing the cotter pin, be sure to split the cotter pin like an anchor.

Tightening torque	Power steering hose	24 to 27 N·m 2.4 to 2.8 kgf·m 18 to 20 lbf·ft
-------------------	---------------------	---

- (1) Hose Clamp (3) Cotter Pin  
 (2) Slotted Nut (Adjusting Nut for Front Axle Rocking Force) (4) Power Steering Hose

9Y1210855FBS0012US0

**Power Steering Cylinder**

1. Remove the cotter pin and remove the slotted nut for tie-rod (1).
2. Remove the power steering cylinder mounting screws and remove the power steering cylinder (2) with tie-rod.

**(When reassembling)**

■ **NOTE**

- **Tighten the slotted nut to 18 N·m (1.8 kgf·m, 13 lbf·ft). If the slot and pin hole do not meet, tighten the nut until they do meet, and install the cotter pin.**
- **Be sure to split the cotter pin like an anchor.**

Tightening torque	Tie-rod slotted nut	18 to 34 N·m 1.8 to 3.5 kgf·m 13 to 25 lbf·ft
	Power steering cylinder mounting screw	48 to 55 N·m 4.9 to 5.7 kgf·m 36 to 41 lbf·ft

- (1) Tie-rod (2) Power Steering Cylinder

9Y1210855FBS0013US0

### [3] DISASSEMBLING AND ASSEMBLING

#### (1) Power Steering Cylinder

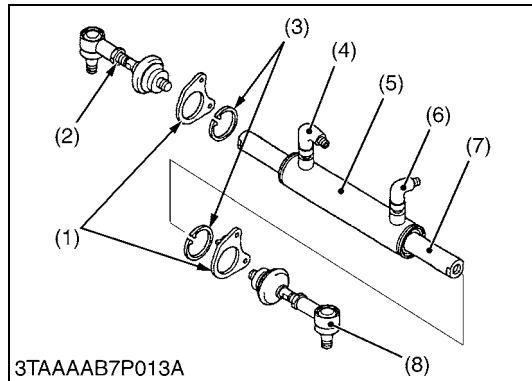

#### Adaptor and Tie-rod

1. Remove the cylinder hose adaptors (4), (6).
2. Remove the tie-rods (2), (8) from piston rod (7).
3. Remove the cylinder holder (1) and internal snap ring (3).

#### (When reassembling)

- Be sure to install the hose adaptors (4), (6) as shown figure left.
- After reassembling the tie-rod, be sure to adjust the toe-in. (See page to 3-S4.)

Tightening torque	Tie-rod screw	74 to 84 N·m 7.5 to 8.6 kgf·m 55 to 62 lbf·ft
-------------------	---------------	---

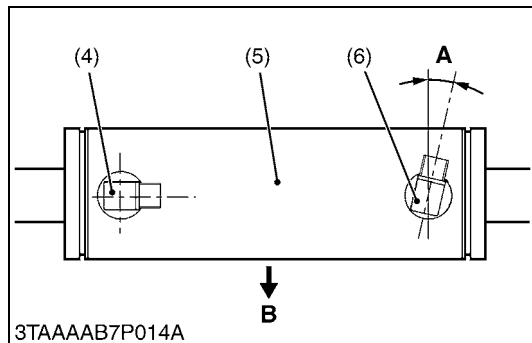

- |                        |                           |
|------------------------|---------------------------|
| (1) Cylinder Holder    | (7) Piston Rod            |
| (2) Tie-rod RH         | (8) Tie-rod LH            |
| (3) Internal Snap Ring |                           |
| (4) Hose Adaptor RH    | <b>A: 0.26 rad (15 °)</b> |
| (5) Cylinder           | <b>B: Front</b>           |
| (6) Hose Adaptor LH    |                           |

9Y1210855STS0009US0

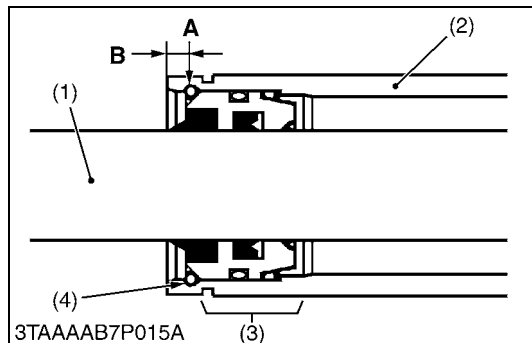

#### Steering Cylinder

1. Carefully clamp the cylinder in a vise.
2. Push one of the guide assembly (3) to inside of cylinder tube (2).
3. Drill a hole (2.5 mm dia., 0.098 in. dia.) on the cylinder tube (2) just over the snap ring (4) as shown figure left.
4. Take a little screwdriver and lift off the snap ring (4) from its groove. Simultaneous support this action by pushing from the outside of the cylinder tube with another little screwdriver or another tool.
5. Push out the piston rod assembly (9) and take off the guide assembly (3).

#### (When reassembling)

#### ■ NOTE

- **Seals must be exchanged after disassembling.**
- **Apply transmission fluid to the exchanged seals.**
- **Enter the piston rod and block the guide assemblies with the snap rings.**

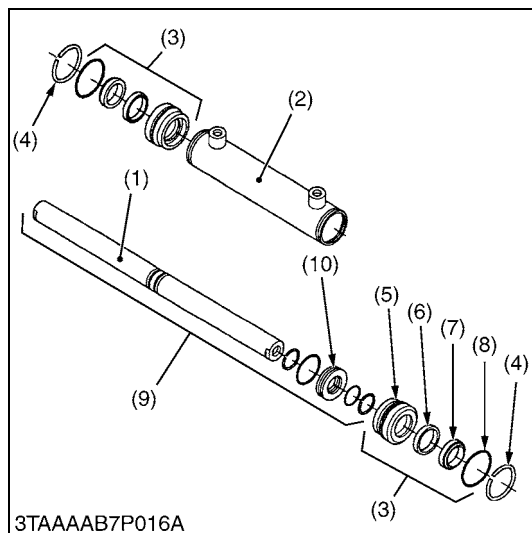

- |                    |                               |
|--------------------|-------------------------------|
| (1) Piston Rod     | (8) O-ring                    |
| (2) Cylinder Tube  | (9) Piston Rod Assembly       |
| (3) Guide Assembly | (10) Center Piston            |
| (4) Snap Ring      |                               |
| (5) Guide          | <b>A: Drill a Hole</b>        |
| (6) Seal Ring      | <b>B: 5.25 mm (0.207 in.)</b> |
| (7) Wiper Ring     |                               |

9Y1210855STS0010US0

## [4] SERVICING

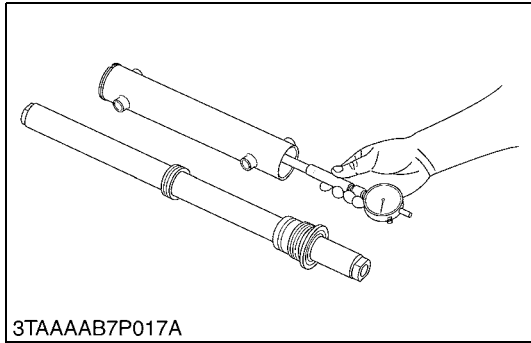

### Steering Cylinder I.D.

1. Measure the steering cylinder I.D. with a cylinder gauge.
2. If the cylinder I.D. exceed the allowable limit, replace the cylinder barrel.

Steering cylinder I.D.	Factory specification	40.000 to 40.062 mm 1.5748 to 1.5772 in.
	Allowable limit	40.100 mm 1.5787 in.

9Y1210855STS0011US0

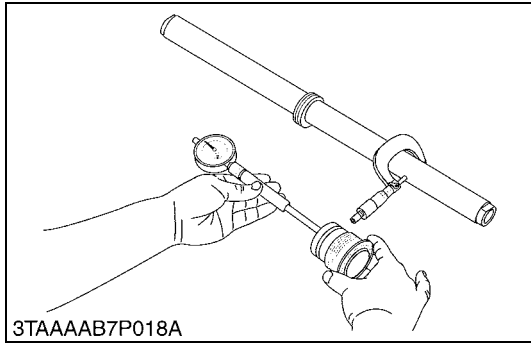

### Clearance between Rod and Guide

1. Measure the rod guide I.D. with a cylinder gauge.
2. Measure the rod O.D. with an outside micrometer, and calculate the clearance.
3. If the clearance exceeds the allowable limit, replace as a unit.

Clearance between rod and guide	Factory specification	0.020 to 0.070 mm 0.00079 to 0.0027 in.
	Allowable limit	0.200 mm 0.00787 in.

9Y1210855STS0012US0

# **5 HYDRAULIC SYSTEM**

# MECHANISM

## CONTENTS

1. HYDRAULIC CIRCUIT .....	5-M1
2. HYDRAULIC PUMP.....	5-M2
3. CONTROL VALVE.....	5-M3
4. FLOW PRIORITY VALVE.....	5-M6
5. RELIEF VALVE.....	5-M7
6. HYDRAULIC CYLINDER.....	5-M9
7. HYDRAULIC BLOCK TYPE OUTLET .....	5-M10
8. MOWER LINKAGE .....	5-M11
9. FRONT LOADER VALVE .....	5-M12
[1] STRUCTURE .....	5-M12
(1) Structure for Front Loader Valve and Pipe .....	5-M12
(2) Structure for Front Loader Control Valve.....	5-M13
[2] FRONT LOADER HYDRAULIC CIRCUIT .....	5-M14
[3] OPERATION .....	5-M15

# 1. HYDRAULIC CIRCUIT

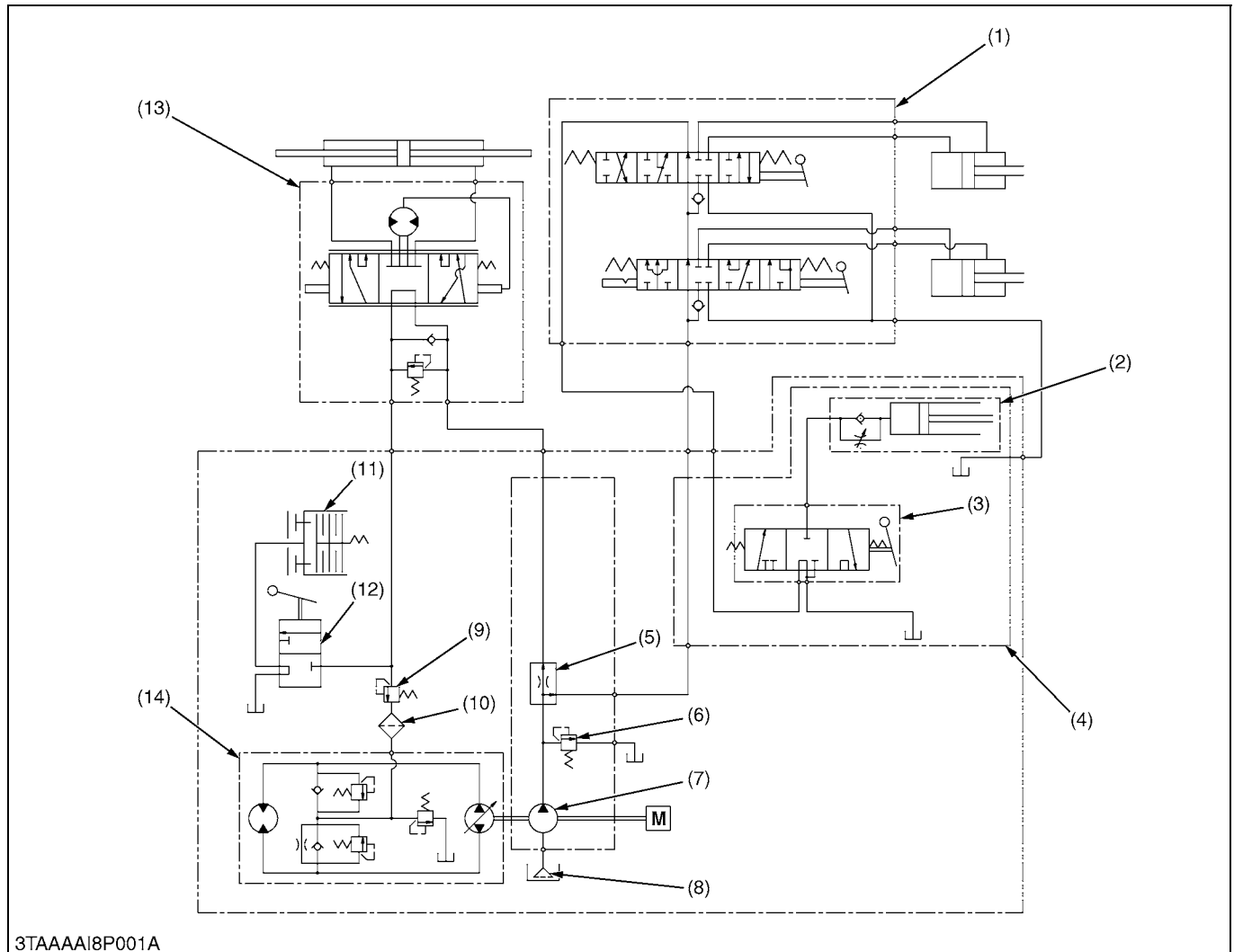

- |  |                          |                             |                                |
|--|--------------------------|-----------------------------|--------------------------------|
| (1) Auxiliary Hydraulic Control Valve Assembly (If equipped) | (4) 3 Point Hitch System | (8) Oil Strainer            | (12) PTO Clutch Valve          |
| (2) Hydraulic Cylinder                                       | (5) Flow Priority Valve  | (9) PTO Clutch Relief Valve | (13) Power Steering Controller |
| (3) Control Valve  | (6) Relief Valve         | (10) Oil Filter             | (14) Hydrostatic Transmission  |
|  | (7) Hydraulic Pump       | (11) PTO Clutch             |                                |

The hydraulic system of this tractor consists of a hydraulic pump, control valve for front loader, 3 point hitch system and other components.

This system has the following functions:

1. Oil is supplied by hydraulic pump which is driven by pump drive shaft in the transmission case. As the pump drive shaft is connected to the propeller shaft, hydraulic pump starts running when engine is started.
2. The hydraulic pump supplies the high pressured oil to auxiliary hydraulic control valve for front loader, control valve for 3 point hitch system, power steering controller, PTO clutch valve and hydrostatic transmission after dividing oil flow by flow priority valve.

9Y1210855HYM0001US0

## 2. HYDRAULIC PUMP

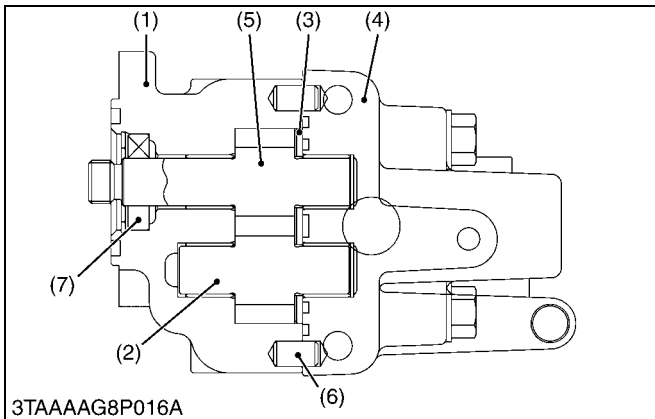
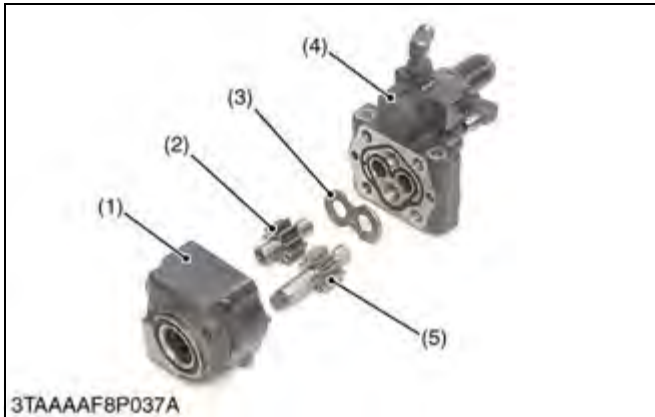

The hydraulic pump consists of the casing (1), cover (4), side plate (3), and two spur gears (drive gear (5) and driven gear (2)) that are in mesh.

Hydraulic pump is driven by the pump drive shaft in the transmission case.

Maximum displacement is as follows.

Displacement	Engine speed	Condition
23.5 L/min. 6.2 U.S.gals/min. 5.2 Imp.gals/min.	At 3200 min <sup>-1</sup> (rpm)	at no load

- (1) Casing
- (2) Driven Gear
- (3) Side Plate
- (4) Cover
- (5) Drive Gear
- (6) Pin
- (7) Oil Seal

9Y1210855HYM0002US0

### 3. CONTROL VALVE

This position control valve is located under the hydraulic cylinder.

This control valve is mechanically connected to the position control lever.

Since the feedback rod is not equipped to the lift arm, the neutral position adjustment is adjusted by controlling the position control lever.

The control valve controls the oil flow forced from the hydraulic pump and the oil returned back from the hydraulic cylinder.

9Y1210855HYM0003US0

#### Neutral

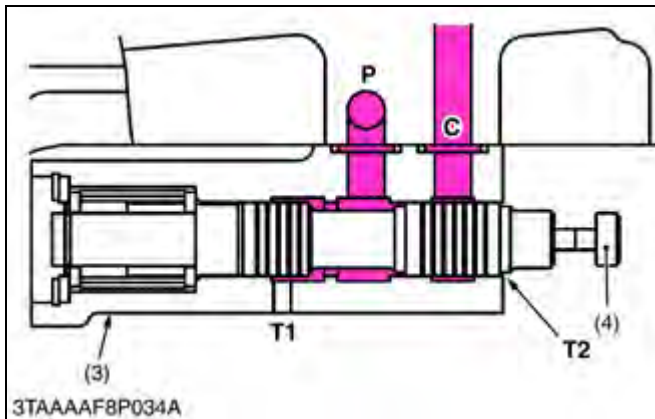
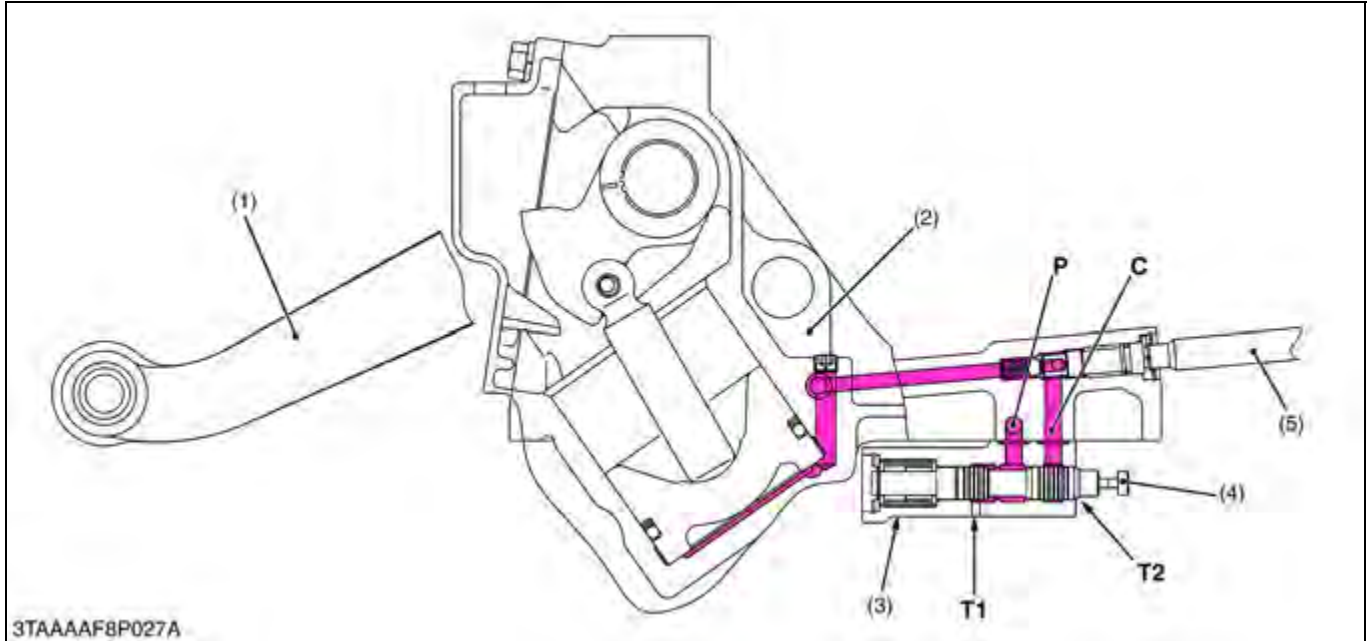

When stopping the position control lever, the spool is stopped.

The spool closes the oil flow from passage between **P** port and **C** port.

Since the oil in the hydraulic cylinder is not drained to **T2** port, "**Neutral**" position is kept.

- |                              |                         |
|------------------------------|-------------------------|
| (1) Lift Arm                 | <b>P: Pump Port</b>     |
| (2) Hydraulic Cylinder       | <b>C: Cylinder Port</b> |
| (3) Control Valve Body       | <b>T1: Tank Port</b>    |
| (4) Spool                    | <b>T2: Tank Port</b>    |
| (5) Lowering Adjusting Shaft |                         |

9Y1210855HYM0004US0



**Lift**

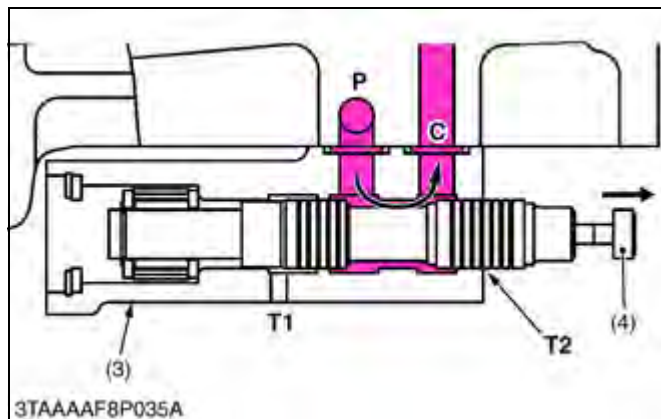
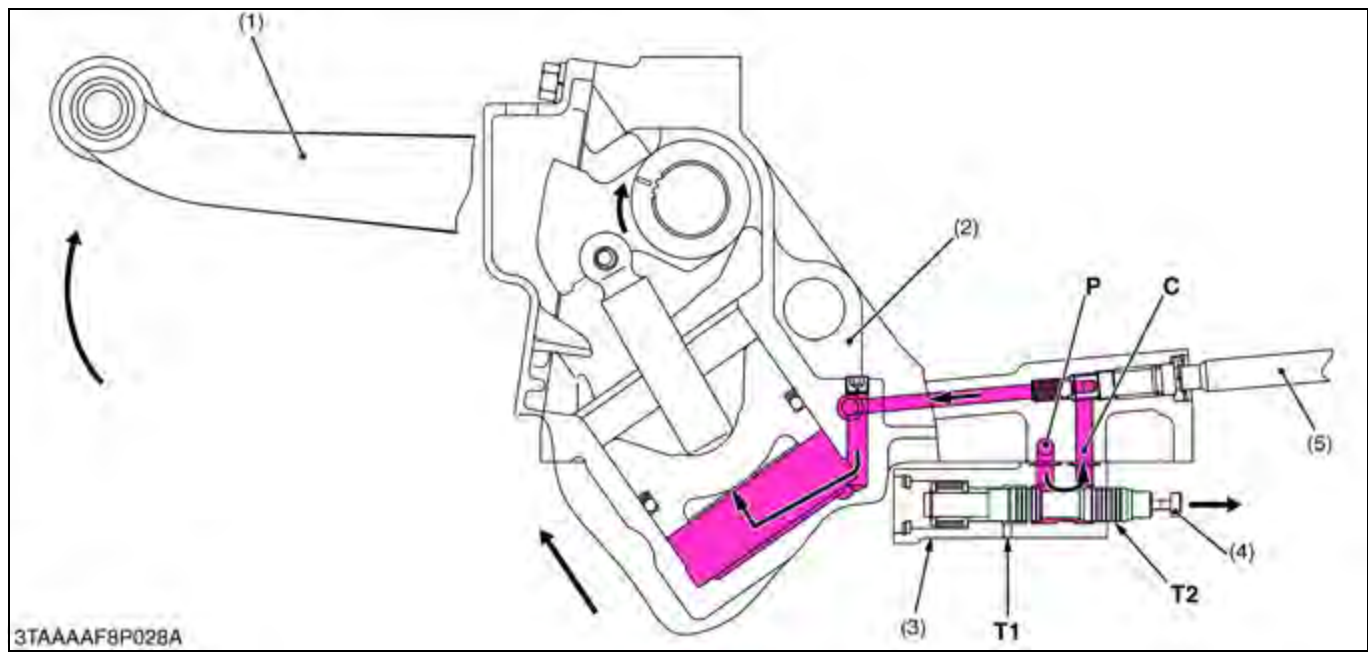

When the control lever is set to the "Lift" position, the spool (4) moves to the right.

The oil forced into the control valve flows through P port to C port and the hydraulic cylinder.

The oil pushes the hydraulic piston in the hydraulic cylinder to lift the implement.

Since the spool shape is step down structure, oil passes slowly through the gap between the control valve body (3) and the spool (4) to C port.

In this tractor, when setting the control lever to the "Slow up", implement lifts up with ease in increments of approximately 1/4 inches at lower link end.

- (1) Lift Arm
- (2) Hydraulic Cylinder
- (3) Control Valve Body
- (4) Spool
- (5) Lowering Adjusting Shaft

- P: Pump Port**
- C: Cylinder Port**
- T1: Tank Port**
- T2: Tank Port**

9Y1210855HYM0005US0

**Down**

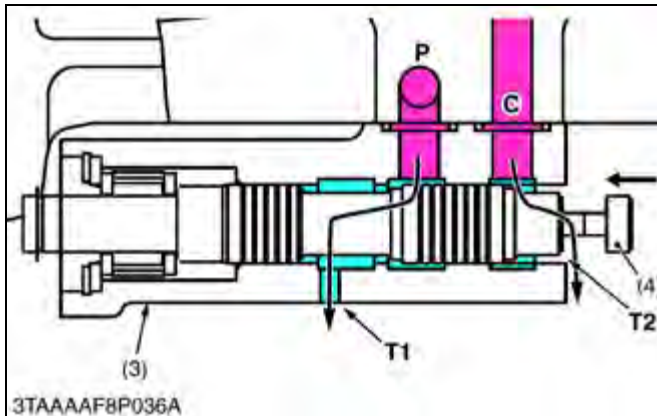
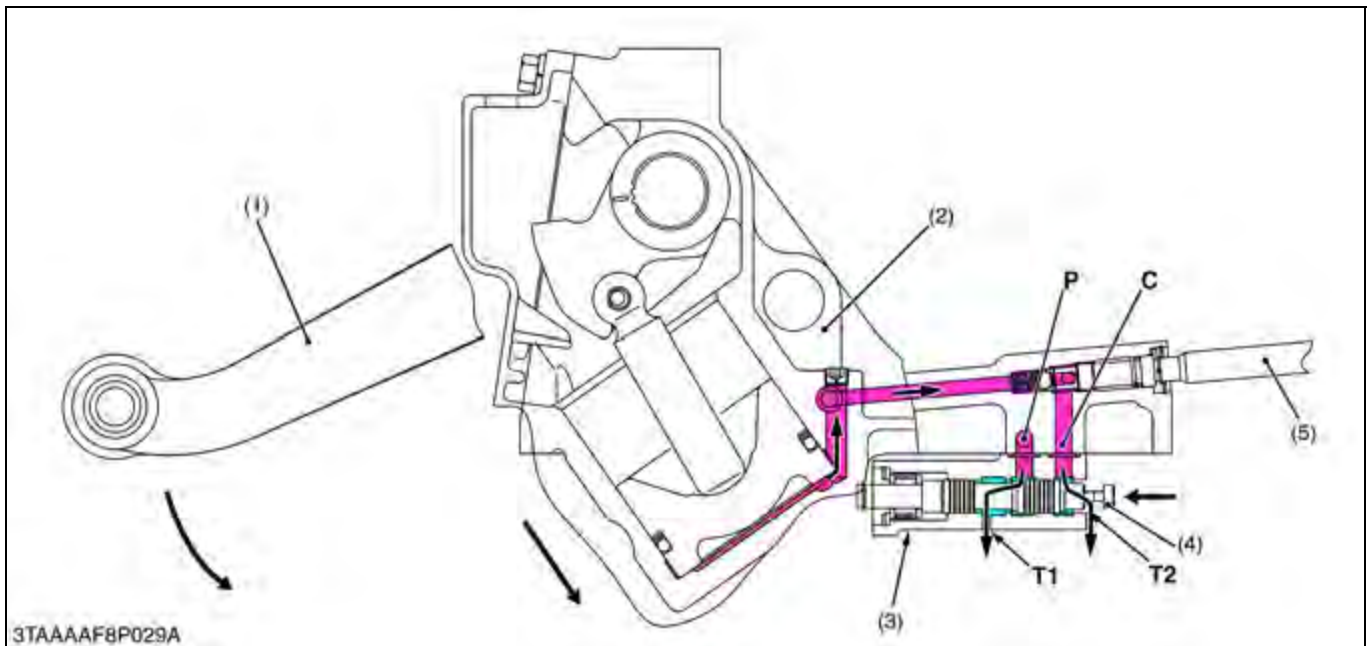

When the control lever is set to the "Down" position, the spool (4) moves to the left.

The oil forced from the P port flows through the gap between the control valve body and the spool to the T1 port.

The oil in the hydraulic cylinder flows through the gap between the control valve body (3) and the spool (4) to the T2 port.

Since the oil in the hydraulic cylinder drains to the transmission case, the implement lowers.

Since the spool shape is step down structure, oil pass slowly from C port through the gap between the control valve body (3) and the spool (4) to T2 port.

In this tractor, when setting the control lever to the "Slow down" position, implement lowers down with ease in increments of approximately 1/4 inches at lower link end.

- |                              |                         |
|------------------------------|-------------------------|
| (1) Lift Arm                 | <b>P: Pump Port</b>     |
| (2) Hydraulic Cylinder       | <b>C: Cylinder Port</b> |
| (3) Control Valve Body       | <b>T1: Tank Port</b>    |
| (4) Spool                    | <b>T2: Tank Port</b>    |
| (5) Lowering Adjusting Shaft |                         |

9Y1210855HYM0006US0

# 4. FLOW PRIORITY VALVE

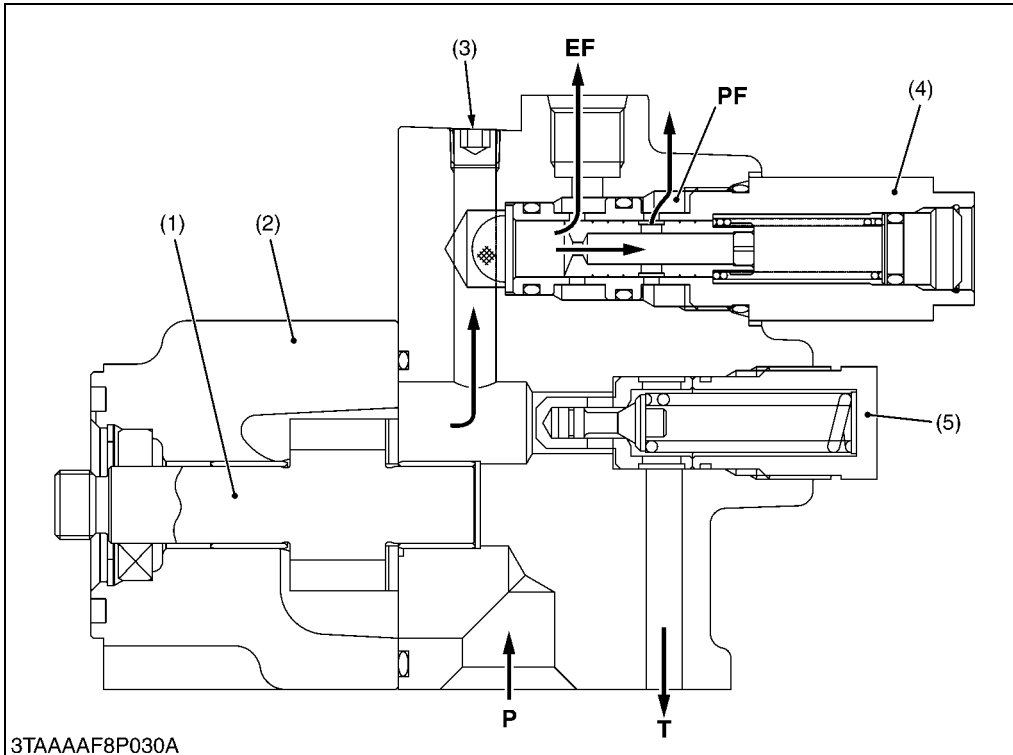

- (1) Hydraulic Pump Gear
- (2) Hydraulic Pump Case
- (3) Plug
- (4) Flow Priority Valve
- (5) Relief Valve

**EF:** EF Port (To 3 Point Hitch Control Circuit)

**PF:** PF Port (To Power Steering, PTO Clutch and HST Circuit)

**P:** Pump Port (Suction)

**T:** Tank Port

3TAAAF8P030A

The flow priority valve is a flow divider that divides single hydraulic source (hydraulic pump) to actuates two circuits simultaneously.

This valve feeds fixedly controlled flow (8.0 L/min., 2.1 U.S.gals/min., 1.8 Imp.gals/min.) to the **PF** port with priority and excessive flow to the **EF** port.

9Y1210855HYM0007US0

# 5. RELIEF VALVE

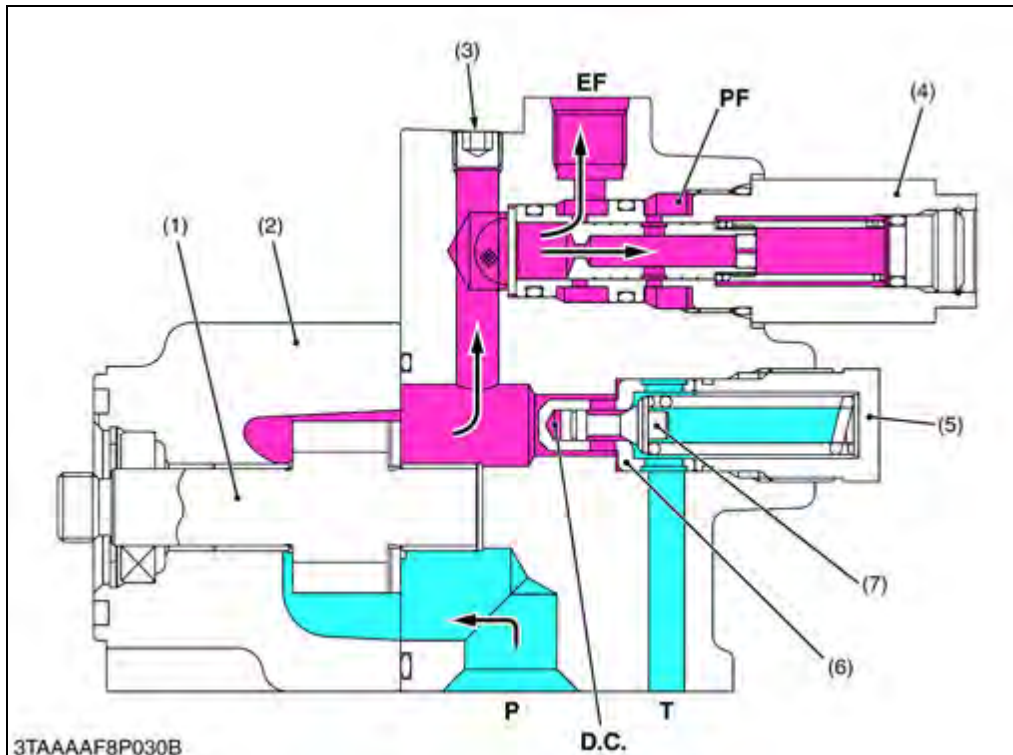

- (1) Hydraulic Pump Gear
- (2) Hydraulic Pump Case
- (3) Plug
- (4) Flow Priority Valve
- (5) Relief Valve
- (6) Seat
- (7) Poppet

**EF:** EF Port (To 3 Point Hitch Control Circuit)

**PF:** PF Port (To Power Steering, PTO Clutch and HST Circuit)

**D.C.:** Damping Chamber

**P:** Pump Port (Suction)

**T:** Tank Ports

The implement control system circuit has a relief valve to restrict the maximum pressure in the circuit. The relief valve is located in the hydraulic control valve assembly.

The relief valve is a guide piston type with damping effect.

Among direct acting relief valves, this type is suited to higher pressure and has large capacity. Furthermore, this type is free from unstable operation, such as chattering, which occurs often in direct acting relief valves.

As shown in the figure, the guide is attached to the poppet (7) and a valve chamber **D.C.** (called the damping chamber) is formed at the top of the guide piston. The inlet of the valve leads to the chamber via a clearance between the sliding portion of the guide and the seat (6), minimizing valve vibration with the damping effect of the chamber.

9Y1210855HYM0008US0

**Relief Valve Operating**

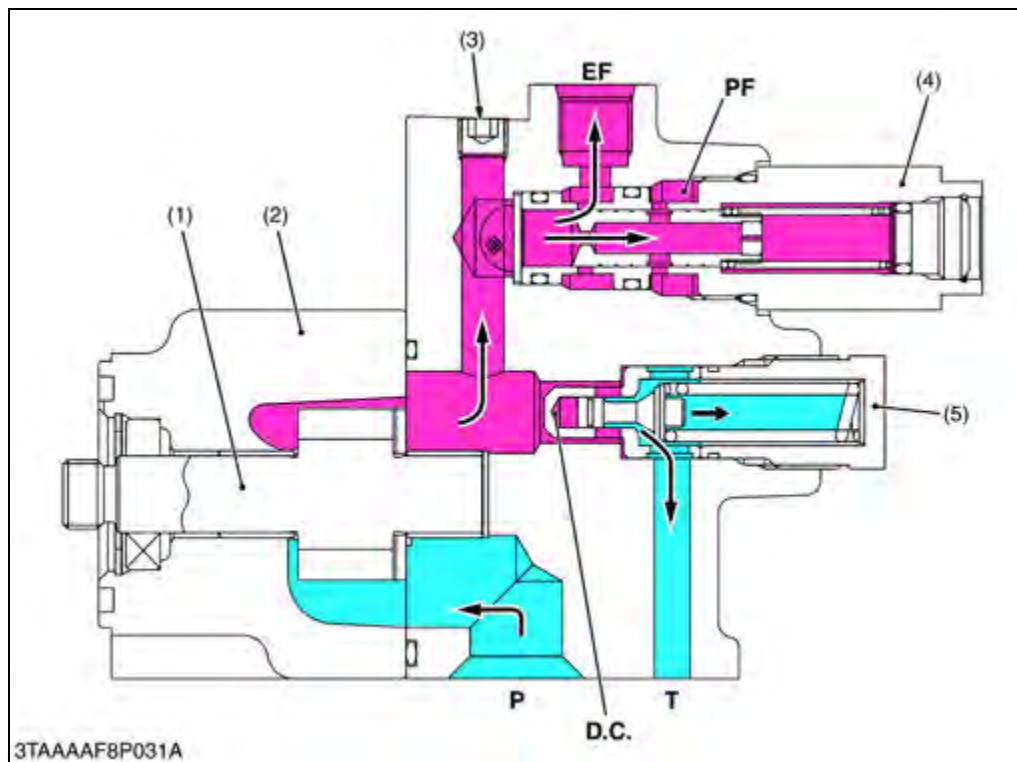

- (1) Hydraulic Pump Gear
- (2) Hydraulic Pump Case
- (3) Plug
- (4) Flow Priority Valve
- (5) Relief Valve

**EF:** EF Port (To 3 Point Hitch Control Circuit)

**PF:** PF Port (To Power Steering, PTO Clutch and HST Circuit)

**D.C.:** Damping Chamber

**P:** Pump Port (Suction)

**T:** Tank Ports

When the oil pressure in the circuit is lower than the setting pressure of the relief valve, the relief valve is not operated and the oil fed to the relief valve from the hydraulic pump flows into the implement control valve.

As the oil pressure in the circuit increases, so does the pressure in the damping chamber **D.C.**. When the pressure rises above the valve setting and overcomes the spring force, the valve opens. Oil then flows out to the transmission case through T port, preventing any further rise in pressure. The valve closes again when enough oil is released to drop pressure below the valve setting.

**(Reference)**

- Relief valve setting pressure:  
12.3 to 12.7 MPa (125 to 130 kgf/cm<sup>2</sup>, 1780 to 1840 psi)
- Engine speed:  
Maximum
- Oil temperature:  
40 to 50 °C (104 to 122 °F)

9Y1210855HYM0009US0

# 6. HYDRAULIC CYLINDER

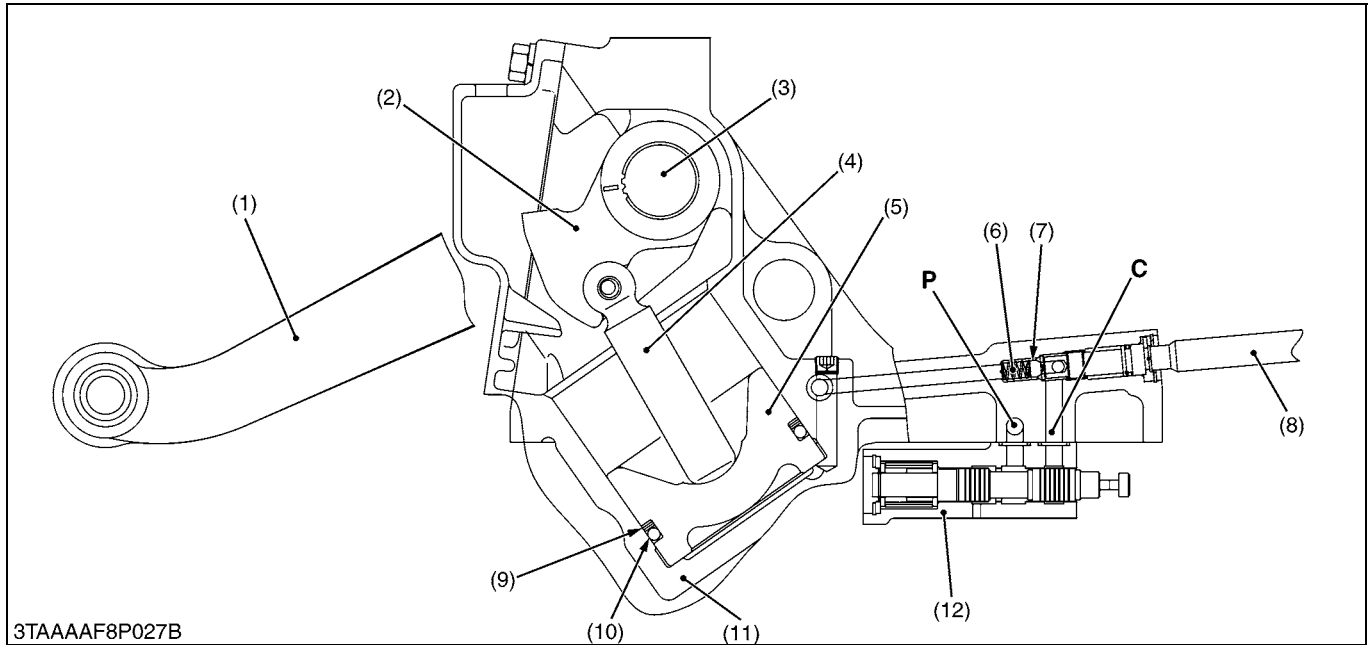

- |                         |                                    |                         |                         |
|-------------------------|------------------------------------|-------------------------|-------------------------|
| (1) Lift Arm            | (6) Spring                         | (9) Back-up Ring        | <b>P: Pump Port</b>     |
| (2) Hydraulic Arm       | (7) Ball                           | (10) O-ring             | <b>C: Cylinder Port</b> |
| (3) Hydraulic Arm Shaft | (8) Lowering Speed Adjusting Shaft | (11) Hydraulic Cylinder |                         |
| (4) Hydraulic Rod       |                                    | (12) Control Valve      |                         |
| (5) Piston              |                                    |                         |                         |

The main components of the hydraulic cylinder are shown in the figure above.

While the lift arm (1) is rising, oil from the hydraulic pump flows into the hydraulic cylinder through the hydraulic control valve (12) and cylinder port **C**. Then oil pushes out the piston (5).

While the lift arm (1) is lowering, oil in the hydraulic cylinder is discharged to the transmission case through the hydraulic control valve by the weight of the implement. At this time, the lowering speed of the implement can be controlled by the ball (7) attached to the hydraulic cylinder (11). Turning the lowering speed adjusting knob clockwise decreases the lowering speed, and counterclockwise increases lowering speed. When the lowering speed adjusting valve is completely closed, the lift arm (1) is held at its position since oil in the hydraulic cylinder is sealed between the piston (5) and ball (7).

9Y1210855HYM0010US0

# 7. HYDRAULIC BLOCK TYPE OUTLET

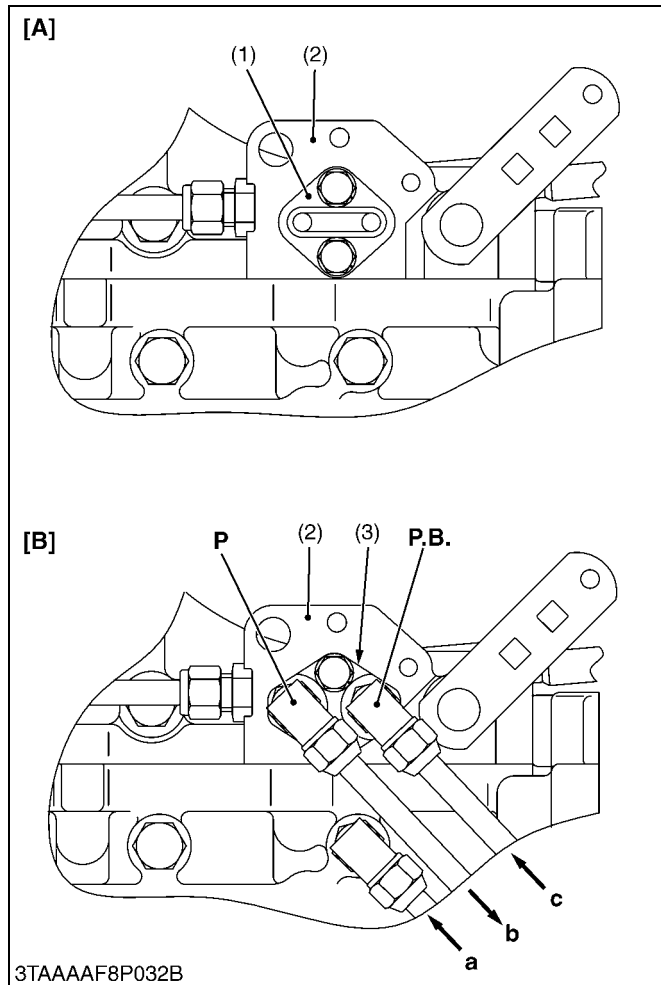

The hydraulic block type outlet is located on the hydraulic cylinder assembly.

This hydraulic block type outlet is provided to take power out from the tractor to operate the hydraulic cylinders on the implement, such as front end loader, front snow blade and so on.

**NOTE**

- This hydraulic block outlet uses for front loader hydraulic system on standard specification.

- (1) Block Cover
- (2) Hydraulic Cylinder
- (3) Hydraulic Block

[A] When auxiliary control valve is not attached.

[B] When auxiliary control valve is attached.

P: P Port (Pump)

P.B.: P.B. Port (Power Beyond)

a: To Transmission Case

b: To Implement

c: From Implement

9Y1210855HYM0011US0

# 8. MOWER LINKAGE

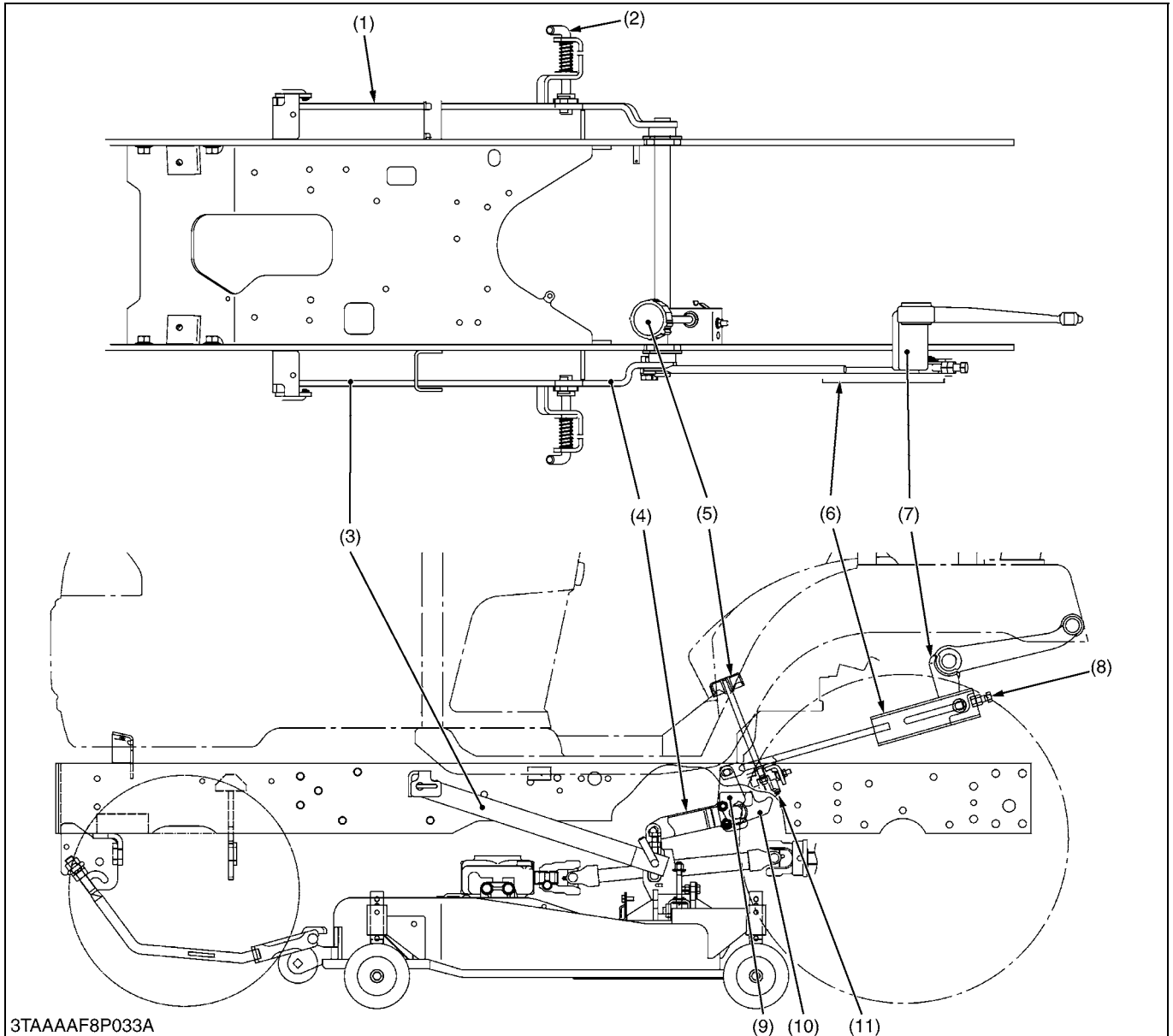

3TAAAF8P033A

- |                        |                                   |                     |                      |
|------------------------|-----------------------------------|---------------------|----------------------|
| (1) Mower Rear Link RH | (4) Rear Lift Link LH             | (7) Lift Arm        | (10) Lift Lower Boss |
| (2) Lift Pin           | (5) Cutting Height Adjusting Dial | (8) Adjusting Bolt  | (11) Cam             |
| (3) Mower Rear Link LH | (6) Rear Lift Link LH             | (9) Lift Upper Boss |                      |

The mower rear link (1), (3) and the lift arm (7) are linked with the rear lift link LH (4), the lift upper boss (9) and the lift lower boss (10).

As the hydraulic control lever moves to lift position, lift arm (7) is raised and the rear lift link LH (6) is pulled to pull the lift links to the rearward. As a result, mower rear link (1), (3) are lifted.

The cutting height adjusting dial (5) adjusts cutting height of mower by rotating the adjusting cam (11). The position of mower rear link (1), (3) are adjusted by changing the length of the adjusting bolt (8).

9Y1210855HYM0012US0



# 9. FRONT LOADER VALVE

## [1] STRUCTURE

### (1) Structure for Front Loader Valve and Pipe

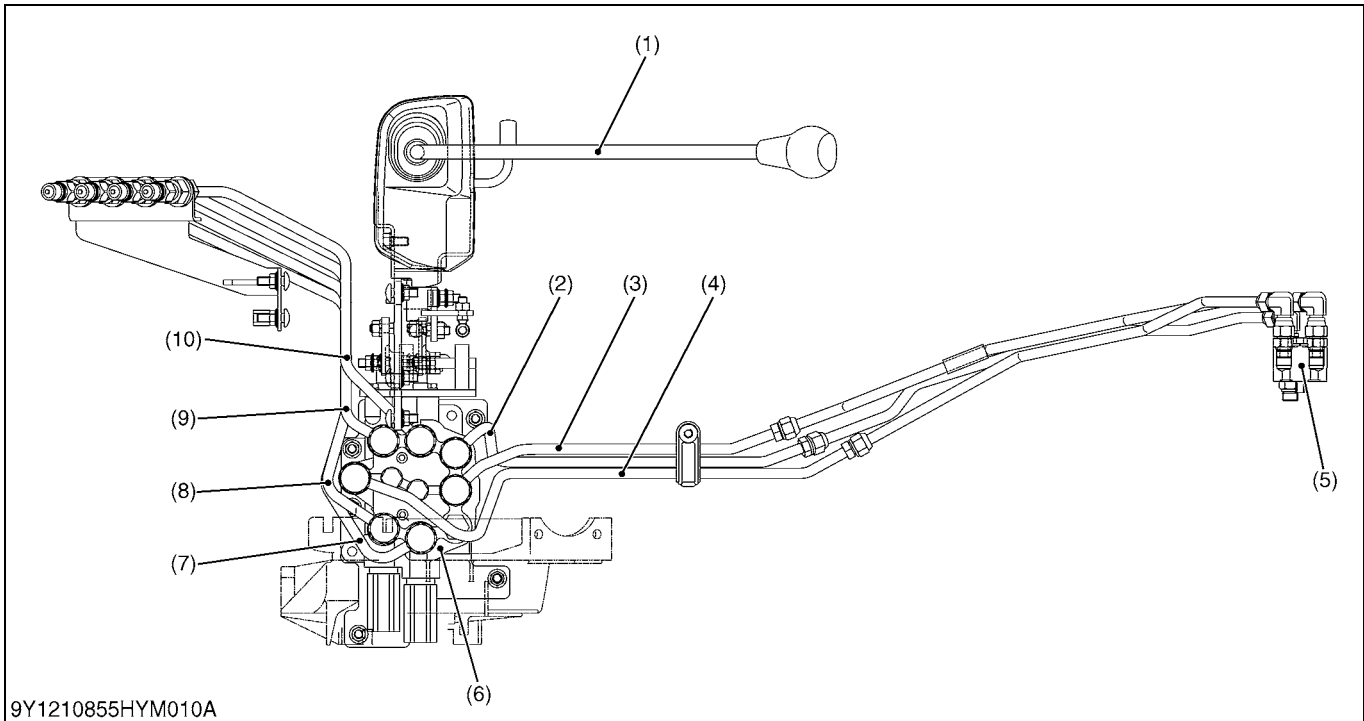

- |                     |                                   |                                   |                                   |
|---------------------|-----------------------------------|-----------------------------------|-----------------------------------|
| (1) Control Lever   | (4) Pipe (Power Beyond)           | (7) Pipe (B1) for Boom Cylinder   | (9) Pipe (A2) for Bucket Cylinder |
| (2) Pipe (Return)   | (5) Hydraulic Outlet (Block Type) | (8) Pipe (B2) for Bucket Cylinder | (10) Pipe (A1) for Boom Cylinder  |
| (3) Pipe (Pressure) | (6) Front Loader Control Valve    |                                   |                                   |

9Y1210855HYM0013US0

## (2) Structure for Front Loader Control Valve

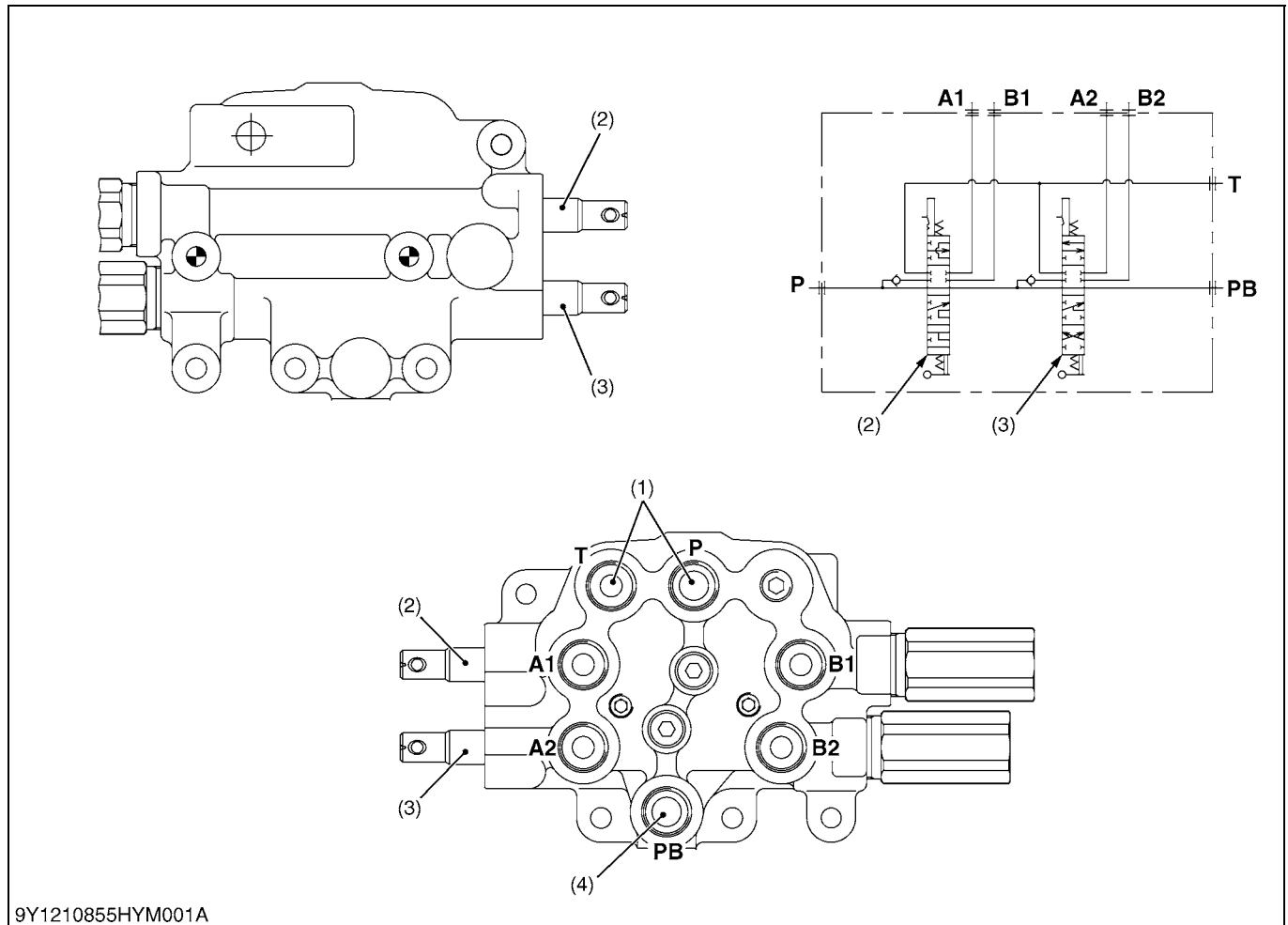

9Y1210855HYM001A

- |                              |                     |                    |                              |
|------------------------------|---------------------|--------------------|------------------------------|
| (1) Inlet and Outlet Section | <b>P: Pump Port</b> | <b>A1: A1 Port</b> | <b>B1: B1 Port</b>           |
| (2) Boom Control Valve       | <b>T: Tank Port</b> | <b>A2: A2 Port</b> | <b>B2: B2 Port</b>           |
| (3) Bucket Control Valve     |                     |                    | <b>PB: Power Beyond Port</b> |
| (4) Power Beyond             |                     |                    |                              |

The control valve assembly consists of one casting block and four major section as shown above.

### (1) Inlet and Outlet Section

This section has **P** and **T** ports.

The **P** port is connected to the **OUTLET** port of hydraulic block by the hydraulic pipe.

The **T** port is connected to the **TANK** port of hydraulic block by the hydraulic pipe.

### (2) Boom Control Section

The boom control valve is of 4-position, 6-connection, detent, spring center type, consisting of a mono block valve housing, spool, load check valve, etc. This valve has **A1** and **B1** ports and controls oil flow to the boom cylinder.

### (3) Bucket Control Section

The bucket control valve is of 4-position, 6-connection, no detent, spring center type, consisting of a mono block valve housing, spool, load check valve, etc. This valve has **A2** and **B2** ports and controls oil flow to the bucket cylinder.

### (4) Power Beyond

This section has **PB** port which is connected to the **INLET** port of hydraulic block by the hydraulic hose, and feeds oil to the three point hydraulic control valve.

9Y1210855HYM0014US0

## [2] FRONT LOADER HYDRAULIC CIRCUIT

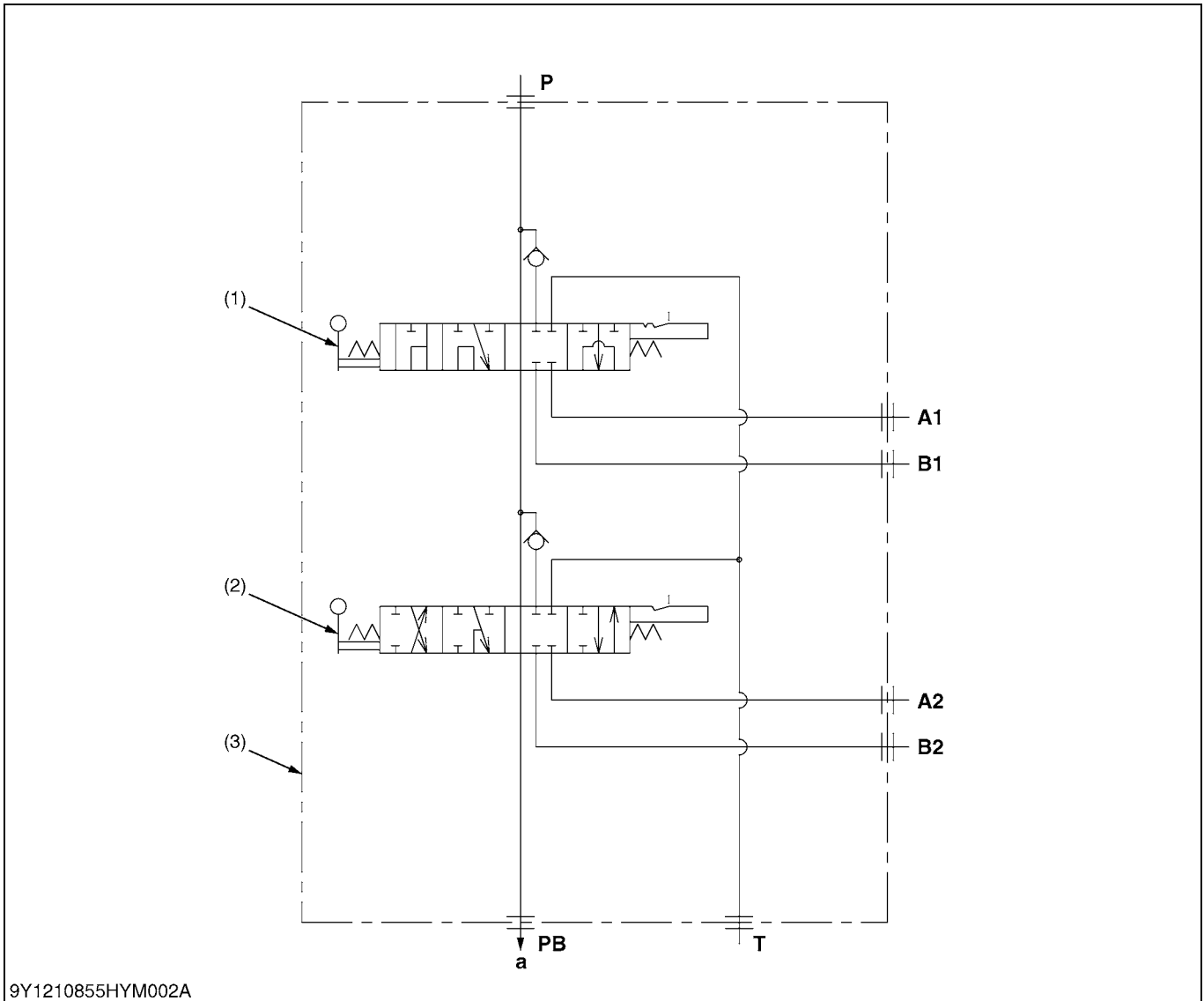

9Y1210855HYM002A

- (1) Boom Control Valve
- (2) Bucket Control Valve
- (3) Front Loader Control Valve

**P: Pump Port**  
**T: Tank Port**

**A1: A1 Port**  
**A2: A2 Port**  
**B1: B1 Port**  
**B2: B2 Port**  
**PB: Power Beyond Port**

**a: To Hydraulic Block**

9Y1210855HYM0015US0

### [3] OPERATION

#### Neutral

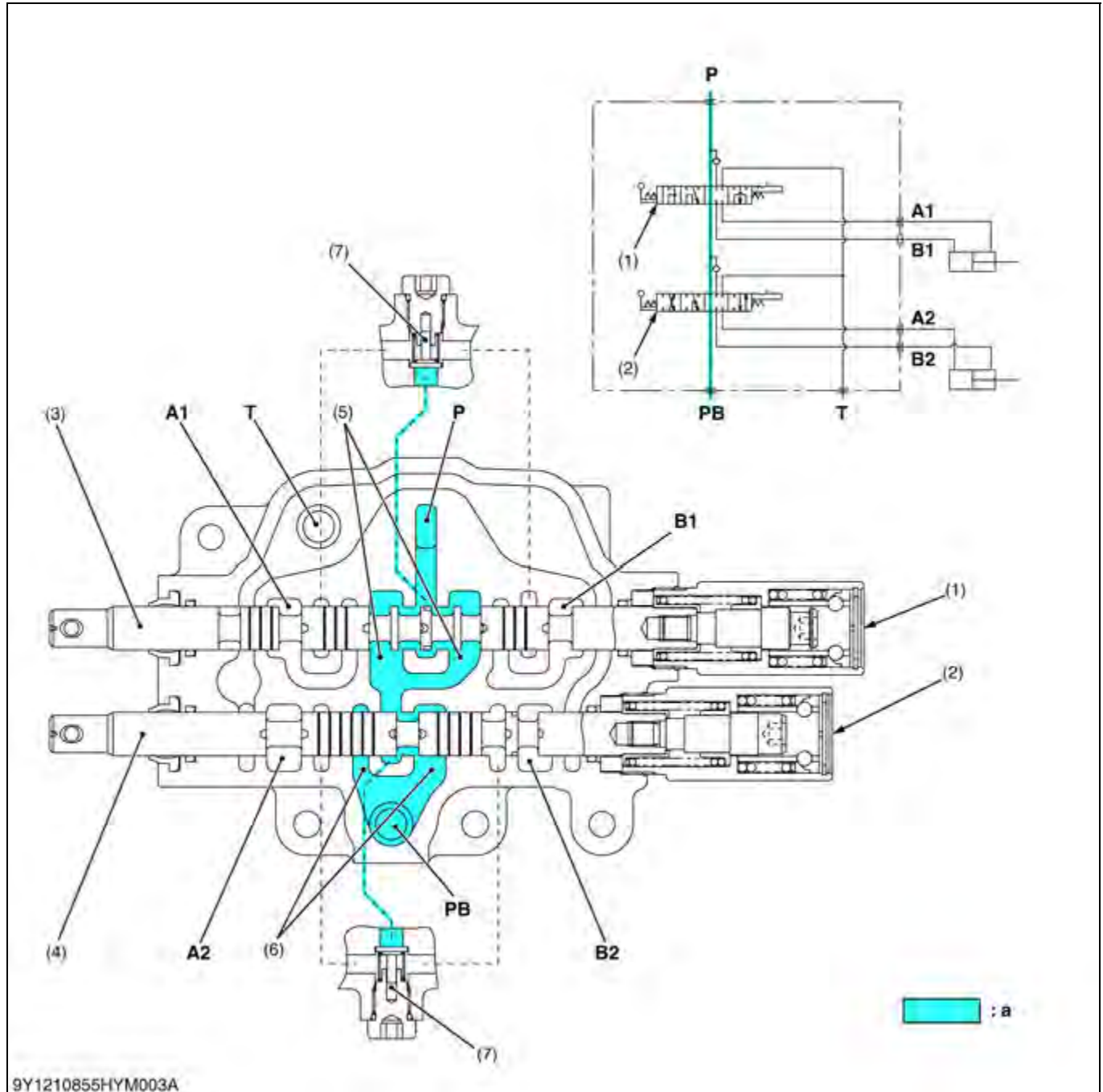

- (1) Boom Control Section
- (2) Bucket Control Section
- (3) Spool
- (4) Spool

- (5) PB Passage 1
- (6) PB Passage 2
- (7) Load Check Valve

- T: Tank Port
- P: Pump Port
- A1: A1 Port
- A2: A2 Port

- B1: B1 Port
- B2: B2 Port
- PB: Power Beyond Port

9Y1210855HYM0016US0

**Up**

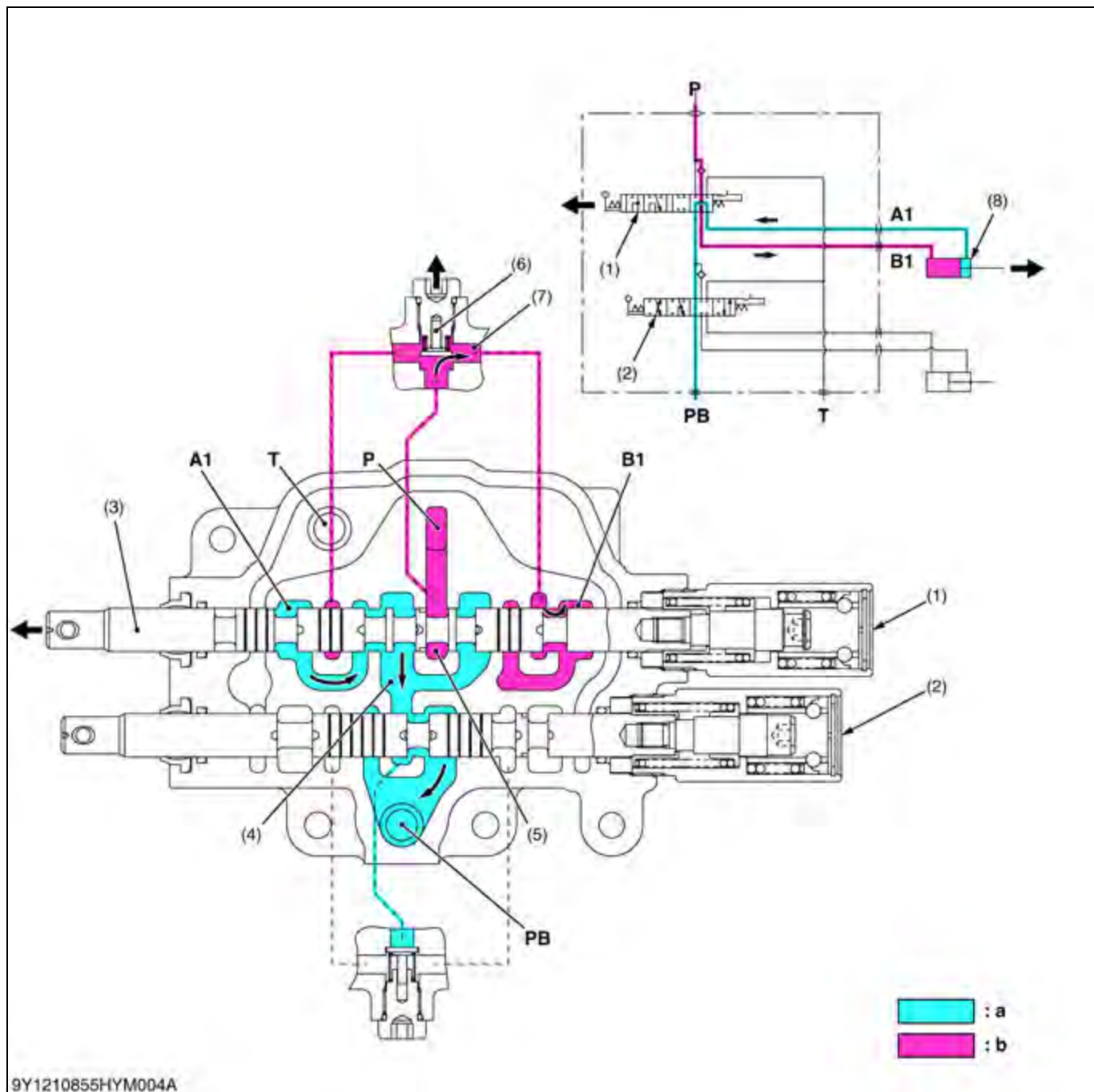

9Y1210855HYM004A

- |                            |                       |                     |                              |
|----------------------------|-----------------------|---------------------|------------------------------|
| (1) Boom Control Section   | (5) Neutral Passage 1 | <b>P: Pump Port</b> | <b>A1: A1 Port</b>           |
| (2) Bucket Control Section | (6) Load Check Valve  | <b>T: Tank Port</b> | (From Boom Cylinder)         |
| (3) Spool                  | (7) Passage 1         |                     | <b>B1: B1 Port</b>           |
| (4) <b>PB</b> Passage 1    | (8) Boom Cylinder     |                     | (To Boom Cylinder)           |
|                            |                       |                     | <b>PB: Power Beyond Port</b> |
|                            |                       |                     | <b>a: Low Pressure</b>       |
|                            |                       |                     | <b>b: High Pressure</b>      |

1. When the hydraulic control lever is set to the "UP" position, the spool (3) of the boom control section (1) moves to the left, which forms oil passages between passage 1 (7) and **B1** port, and between **A1** port and **PB** passage 1 (4).
2. As the oil passage from the neutral passage 1 (5) to the **PB** passage 1 (4) is closed by the spool (3), the pressure-fed oil from the **P** port opens the load check valve (6) and flows through the notched section of the spool (3) and **B1** port to extend the boom cylinder (8).
3. Return oil from the boom cylinder (8) flows from the **A1** port through the passage in the spool (3) and **PB** passage 1 (4) to the bucket control section (2).

9Y1210855HYM0017US0

**Down**

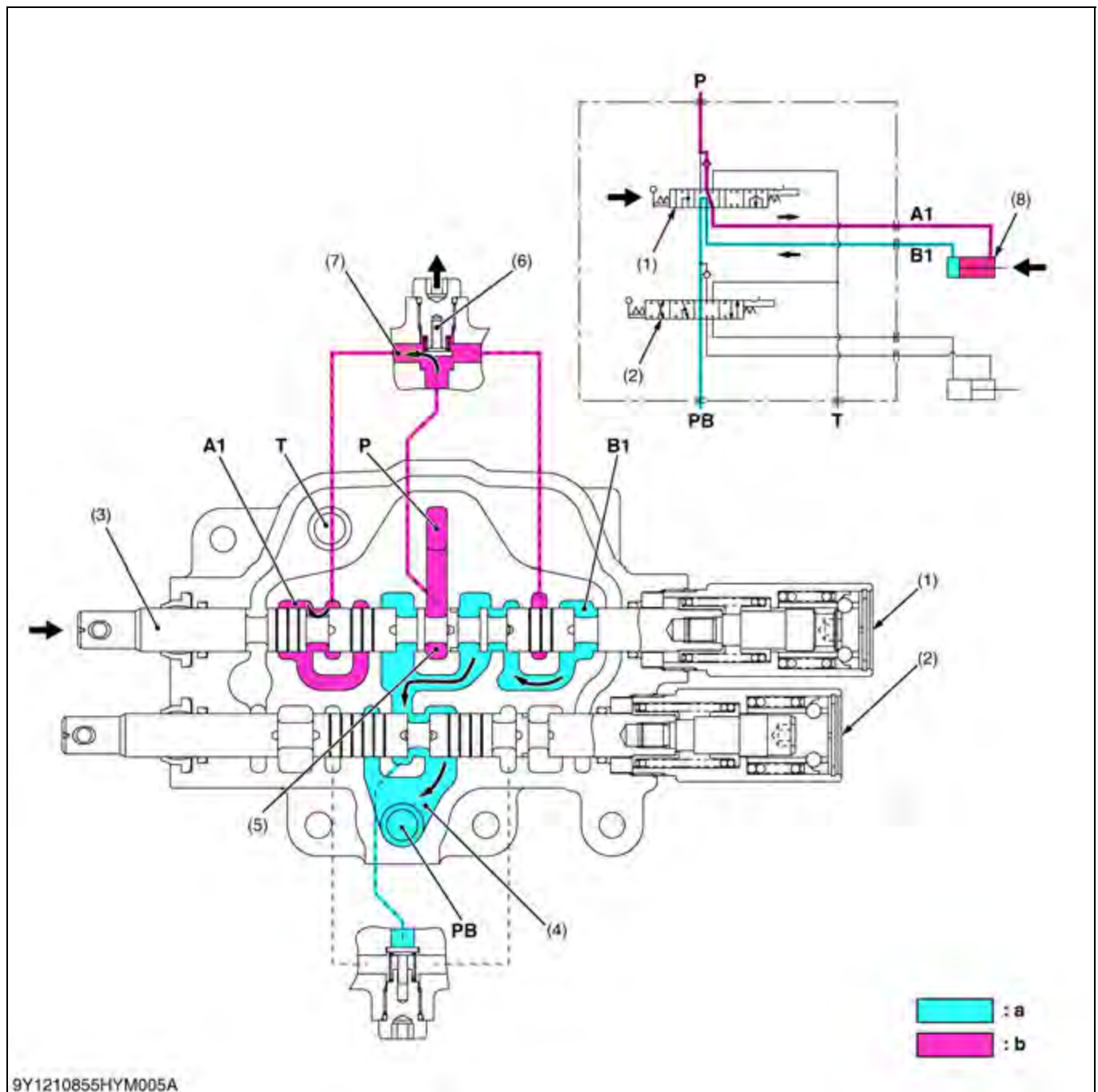

9Y1210855HYM005A

- |                            |                       |                     |                              |
|----------------------------|-----------------------|---------------------|------------------------------|
| (1) Boom Control Section   | (5) Neutral Passage 1 | <b>P:</b> Pump Port | <b>A1:</b> A1 Port           |
| (2) Bucket Control Section | (6) Load Check Valve  | <b>T:</b> Tank Port | (To Boom Cylinder)           |
| (3) Spool                  | (7) Passage 1         |                     | <b>B1:</b> B1 Port           |
| (4) <b>PB</b> Passage 1    | (8) Boom Cylinder     |                     | (From Boom Cylinder)         |
|                            |                       |                     | <b>PB:</b> Power Beyond Port |
|                            |                       |                     | <b>a:</b> Low Pressure       |
|                            |                       |                     | <b>b:</b> High Pressure      |

- When the hydraulic control lever is set to the "DOWN" position, the spool (3) moves to the right, which forms oil passages between passage 1 (7) and A1 port, and between B1 port and PB passage 1 (4).
- As the oil passage from the neutral passage 1 (5) to the PB passage 1 (4) is closed by the spool (3), the pressure-fed oil from the P port opens the load check valve (6) and flows through the notched section of the spool (3) and A1 port to retract the boom cylinder (8).
- Return oil from the boom cylinder (8) flows from the B1 port through the passage in the spool (3) and PB passage 1 (4) to the bucket control section (2).

9Y1210855HYM0018US0



**Floating**

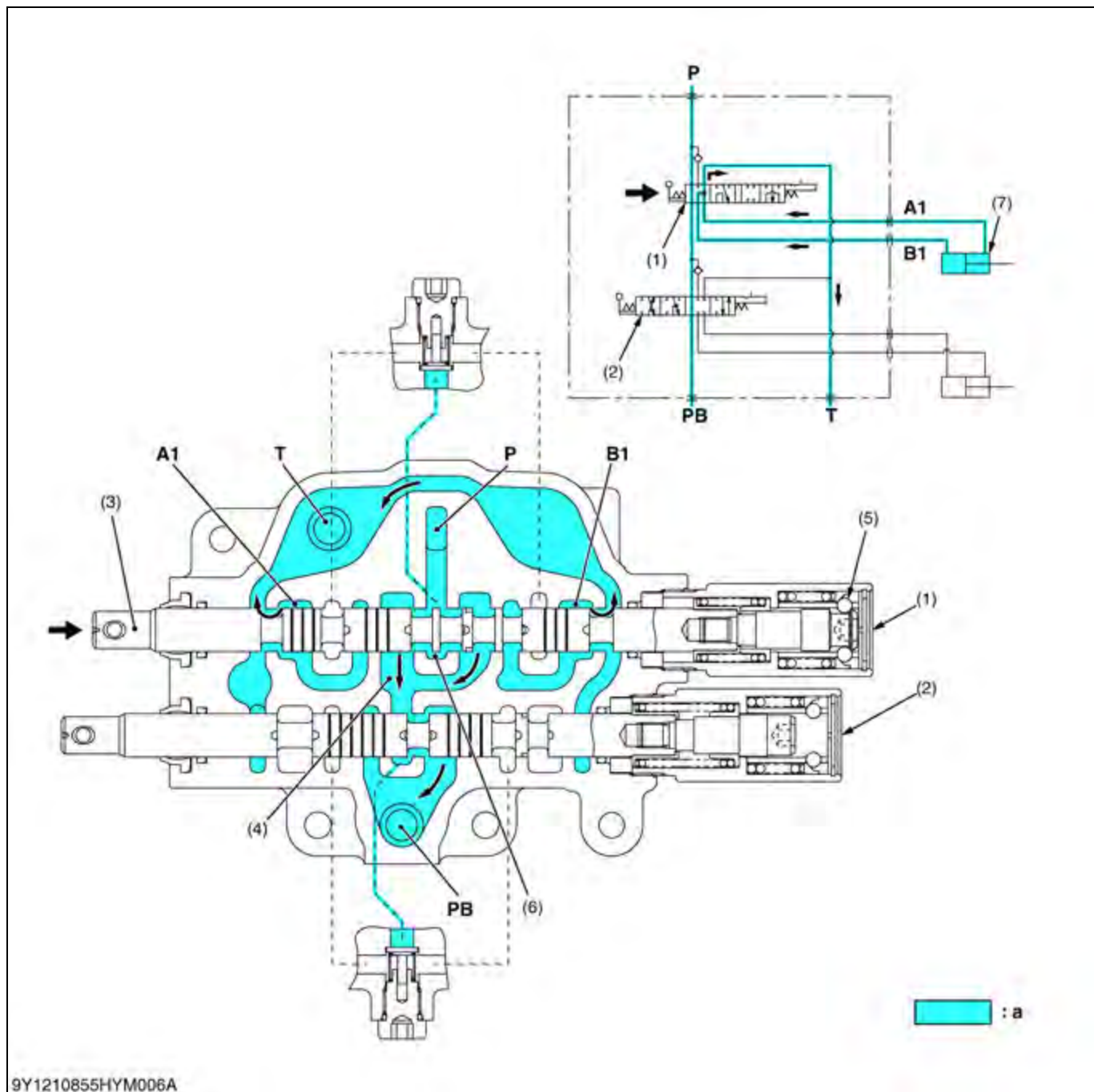

9Y1210855HYM006A

- |                            |                       |                     |                              |
|----------------------------|-----------------------|---------------------|------------------------------|
| (1) Boom Control Section   | (5) Detent Mechanism  | <b>P: Pump Port</b> | <b>A1: A1 Port</b>           |
| (2) Bucket Control Section | (6) Neutral Passage 1 | <b>T: Tank Port</b> | <b>B1: B1 Port</b>           |
| (3) Spool                  | (7) Boom Cylinder     |                     | <b>PB: Power Beyond Port</b> |
| (4) <b>PB</b> Passage 1    |                       |                     | <b>a: Low Pressure</b>       |

1. When the hydraulic control lever is set to the "FLOAT" position, the spool (3) moves further to the right from the "DOWN" position and is retained by the detent mechanism (5).
2. This forms oil passages among the **A1** port, **B1** port and **T** port. As a result, oil in the boom cylinder (7) flows freely from the **A1** port and **B1** port through the **T** port to the transmission case.
3. Oil entering the **P** port flows to the bucket control section (2) through the neutral passage 1 (6) and **PB** passage 1 (4).

9Y1210855HYM0019US0

**Roll-back**

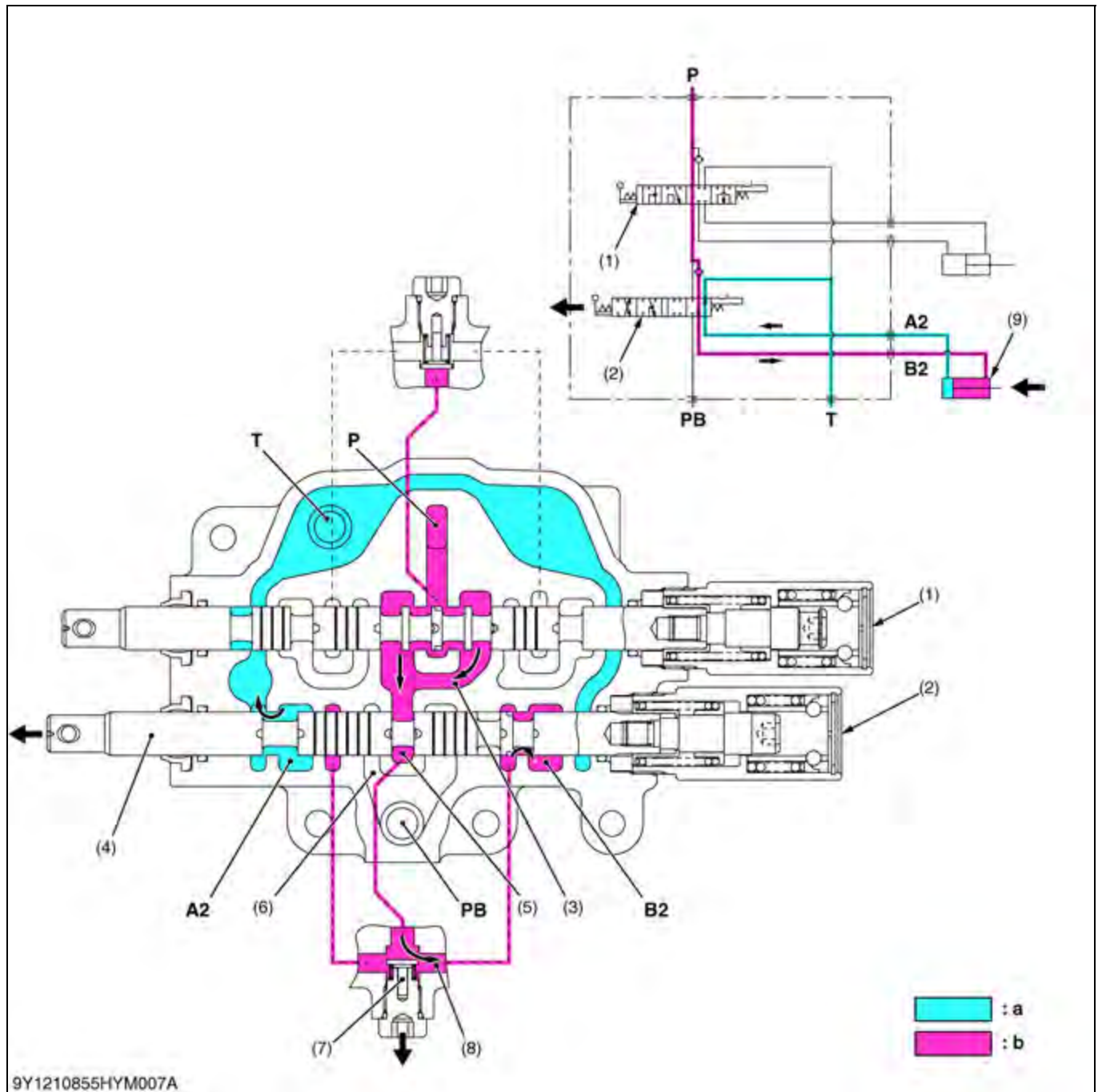

9Y1210855HYM007A

- |                            |                      |                              |                         |
|----------------------------|----------------------|------------------------------|-------------------------|
| (1) Boom Control Section   | (6) PB Passage 2     | <b>P:</b> Pump Port          | <b>B2:</b> B2 Port      |
| (2) Bucket Control Section | (7) Load Check Valve | <b>T:</b> Tank Port          | (To Bucket Cylinder)    |
| (3) PB Passage 1           | (8) Passage 2        | <b>PB:</b> Power Beyond Port | <b>a:</b> Low Pressure  |
| (4) Spool                  | (9) Bucket Cylinder  | <b>A2:</b> A2 Port           | <b>b:</b> High Pressure |
| (5) Neutral Passage 2      |                      | (From Bucket Cylinder)       |                         |

- When the hydraulic control lever is set to the "ROLL-BACK" position, the spool (4) of the bucket control section (2) moves to the left, which forms oil passages between passage 2 (8) and B2 port, and between A2 port and T port.
- The pressure-fed oil from the P port flows to the neutral passage 2 (5) through the boom control section (1) and PB passage 1 (3). As the oil passage from the neutral passage 2 (5) to the PB passage 2 (6) is closed by the spool (4), this oil opens the load check valve (7), and flows through the notched section of the spool (4) and B2 port to retract the bucket cylinder (9).
- Return oil from the bucket cylinder (9) flows to the transmission case through the A2 port and T port.

9Y1210855HYM0020U00



**Dump 1**

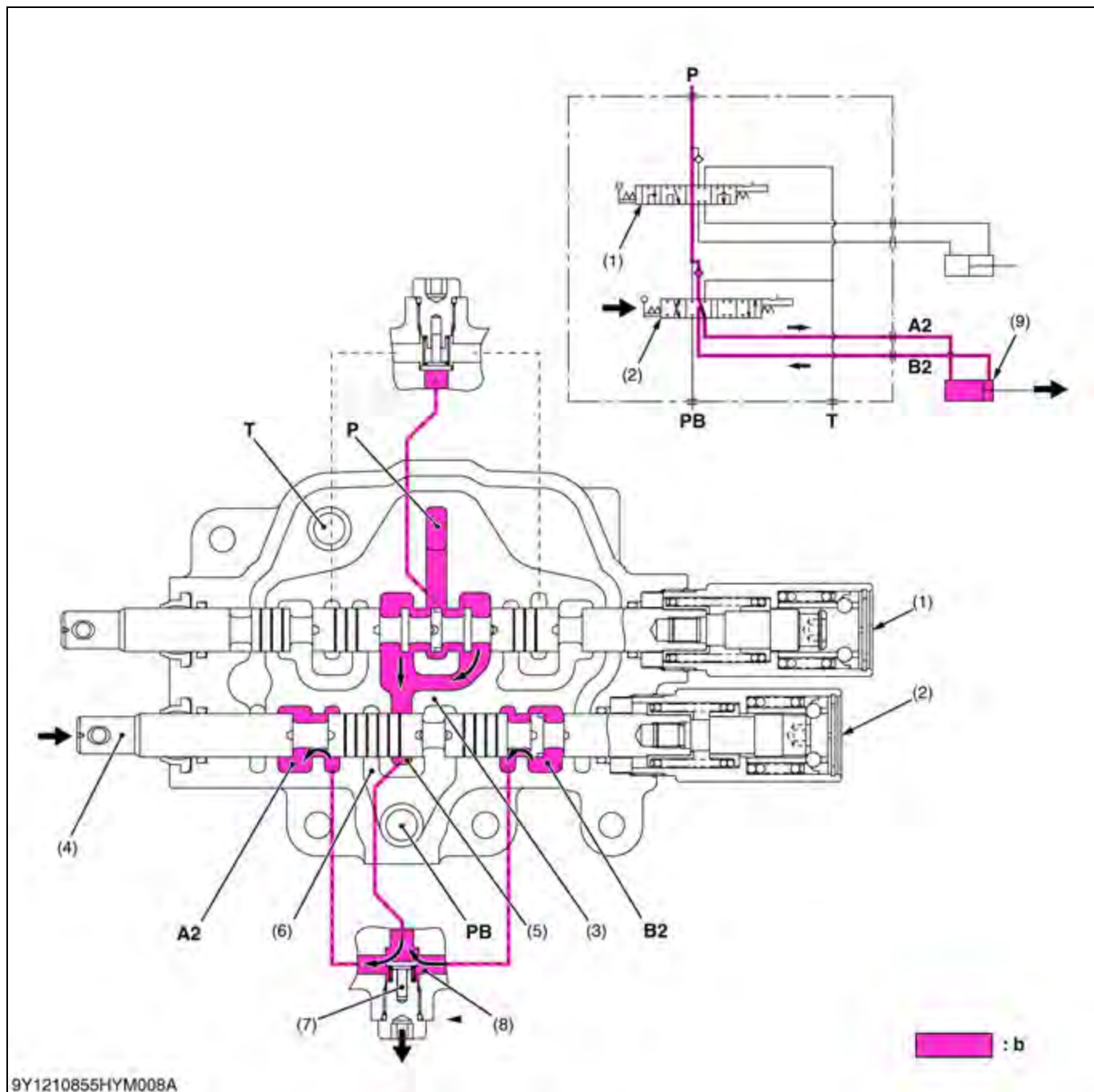

9Y1210855HYM008A

- |                            |                      |                              |                         |
|----------------------------|----------------------|------------------------------|-------------------------|
| (1) Boom Control Section   | (6) PB Passage 2     | <b>P:</b> Pump Port          | <b>A2:</b> A2 Port      |
| (2) Bucket Control Section | (7) Load Check Valve | <b>T:</b> Tank Port          | (To Bucket Cylinder)    |
| (3) PB Passage 1           | (8) Passage 2        | <b>PB:</b> Power Beyond Port | <b>B2:</b> B2 Port      |
| (4) Spool                  | (9) Bucket Cylinder  |                              | (From Bucket Cylinder)  |
| (5) Neutral Passage 2      |                      |                              | <b>b:</b> High Pressure |

- When the hydraulic control lever is set to the "DUMP 1" position, the spool (4), which forms oil passages among passage 2 (8), A2 port and B2 port moves to the right.
- The pressure-fed oil from the P port flows through the boom control valve, opens the load check valve, and flows to the bracket cylinder to extend the cylinder through the notched section of the spool and A2 port.
- Return oil from the bucket cylinder (9) flows from the B2 port to the passage 2 (8), and flows to the A2 port together with the pressure-fed oil from the P port. As a result, the dump speed is increased.

**(Reference)**

- The oil pressure of the A2 port and B2 port is identical, but the bucket cylinder extend by the difference of received pressure area (cylinder rod part).

9Y1210855HYM0021US0

**Dump 2**

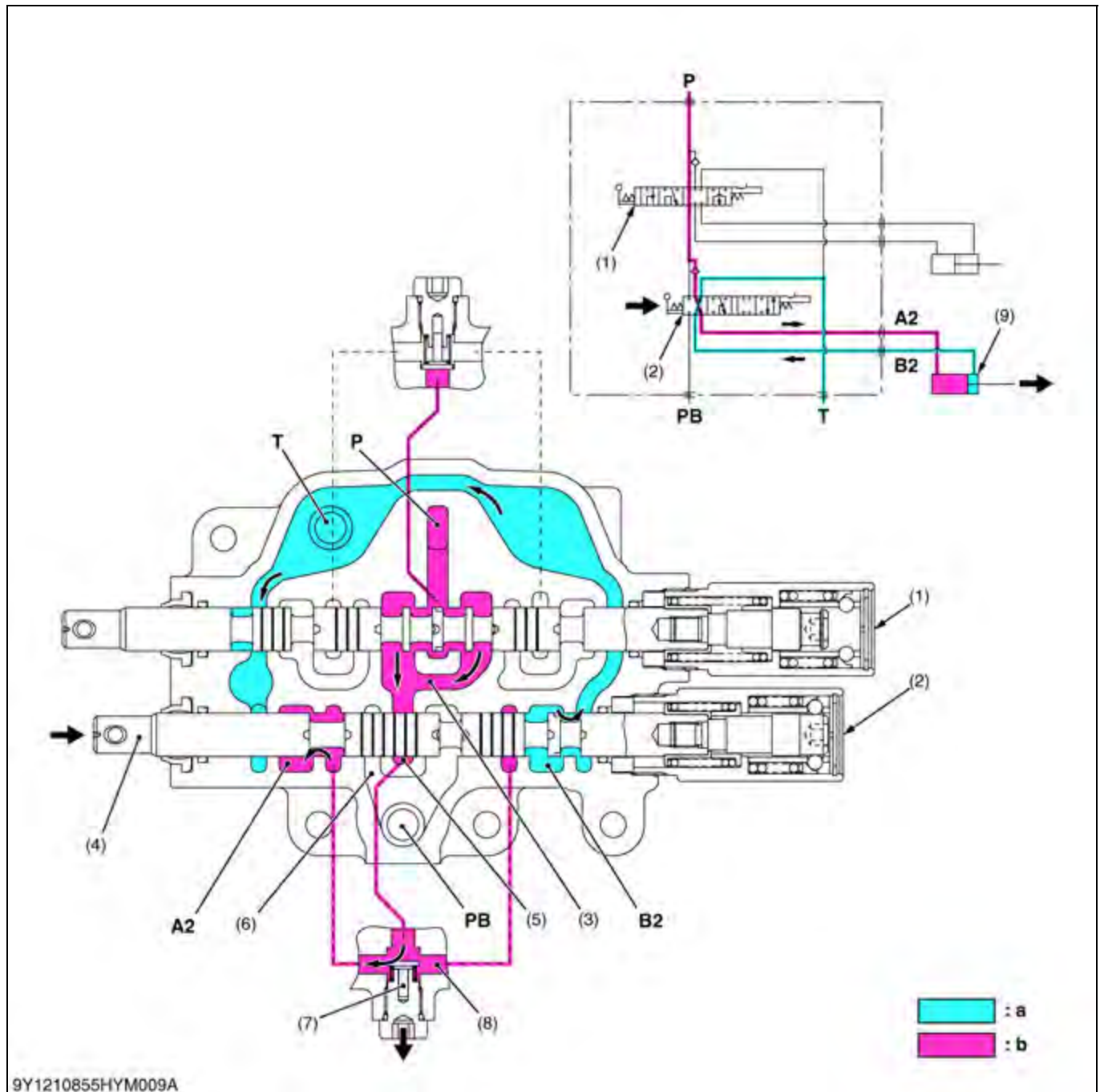

9Y1210855HYM009A

- |                            |                      |                              |                         |
|----------------------------|----------------------|------------------------------|-------------------------|
| (1) Boom Control Section   | (6) PB Passage 2     | <b>P:</b> Pump Port          | <b>A2:</b> A2 Port      |
| (2) Bucket Control Section | (7) Load Check Valve | <b>T:</b> Tank Port          | (To Bucket Cylinder)    |
| (3) PB Passage 1           | (8) Passage 2        | <b>PB:</b> Power Beyond Port | <b>B2:</b> B2 Port      |
| (4) Spool                  | (9) Bucket Cylinder  |                              | (From Bucket Cylinder)  |
| (5) Neutral Passage 2      |                      |                              | <b>a:</b> Low Pressure  |
|                            |                      |                              | <b>b:</b> High Pressure |

- When the hydraulic control lever is set to the "DUMP 2" position, the spool (4) of the bucket control section (2) moves to the right of the bucket control section (2) moves further to the right from the "DUMP 1" position, which forms oil passages between passage 2 (8) and A2 port, and between B2 port and T port.
- The pressure-fed oil from the P port flows to the neutral passage 2 (5) through the boom control section (1) and PB passage 1 (3). As the oil passage from the neutral passage 2 (5) to the PB passage 2 (6) is closed by the spool (4), this oil opens the load check valve (7) and flows through the notched section of the spool (4) and B2 port to extend the bucket cylinder (9).
- Return oil from the bucket cylinder (9) flows to the transmission case through the B2 port and T port.

9Y1210855HYM0022US0

# SERVICING

## CONTENTS

1. TROUBLESHOOTING.....	5-S1
2. SERVICING SPECIFICATIONS.....	5-S2
3. TIGHTENING TORQUES.....	5-S3
4. CHECKING, DISASSEMBLING AND SERVICING.....	5-S4
[1] CHECKING AND ADJUSTING.....	5-S4
(1) Relief Valve.....	5-S4
(2) Pump and Priority Valve.....	5-S5
(3) Mower Lift Linkage.....	5-S7
[2] PREPARATION.....	5-S8
[3] SEPARATING.....	5-S11
(1) Hydraulic Cylinder Block.....	5-S11
(2) Hydraulic Pump.....	5-S11
[4] DISASSEMBLING AND ASSEMBLING.....	5-S12
(1) Hydraulic Cylinder and Control Valve.....	5-S12
(2) Mower Lift Linkage.....	5-S14
(3) Control Valve (Front Loader).....	5-S15
[5] SERVICING.....	5-S18
(1) Hydraulic Pump.....	5-S18
(2) Hydraulic Cylinder.....	5-S19

# 1. TROUBLESHOOTING

Symptom	Probable Cause	Solution	Reference Page
<b>Implement Does Not Rise (No Noise)</b>	Control valve broken	Replace	5-S12
	Control valve improperly assembled	Repair	5-S12
	Relief valve spring damaged	Replace	5-S4
	Spool sticks	Repair	5-S12
	Piston O-ring or cylinder damaged	Replace	5-S12
<b>Implement Does Not Rise (Noise)</b>	Oil filter cartridge clogged	Replace	G-22
	Suction pipe loosen or broken	Repair or replace	–
	Suction pipe connecting hose loosen or broken	Repair or replace	–
	Suction pipe O-ring broken	Replace	–
	Insufficient transmission oil	Refill	G-32
	Relief valve setting pressure too low	Adjust or replace	5-S4
	Hydraulic pump broken	Replace	–
<b>Implement Does Not Lower</b>	Control valve malfunctioning	Repair or replace	5-S12
<b>Implement Drops by Its Weight</b>	Hydraulic cylinder worn or damaged	Replace	5-S19
	Piston O-ring worn or damaged	Replace	5-S12
	Control valve malfunctioning	Replace	5-S12

9Y1210855HYS0001US0

## 2. SERVICING SPECIFICATIONS

Item		Factory Specification	Allowable Limit
Relief Valve <b>(Condition)</b> • Engine Speed: Maximum • Oil Temperature: 45 to 55 °C (113 to 131 °F)	Setting Pressure	12.3 to 12.7 MPa 125 to 130 kgf/cm <sup>2</sup> 1780 to 1840 psi	–
Hydraulic Pump <b>(Condition)</b> • Engine Speed: 1500 min <sup>-1</sup> (rpm) • Oil Temperature: 45 to 55 °C (113 to 131 °F)	Power Steering Oil Flow	Above 8.0 L/min. 2.1 U.S.gals/min. 1.8 Imp.gals/min.	–
Mower Linkage	Clearance "L2"	0 to 0.5 mm 0 to 0.01 in.	–
<b>[Hydraulic Pump]</b> Gear to Casing  • Gear  • Case	Clearance	–	0.15 mm 0.0059 in.
	O.D.	33.520 to 33.530 mm 1.3197 to 1.3200 in.	–
	I.D.	33.570 to 33.577 mm 1.3217 to 1.3219 in.	–
	Clearance	0.020 to 0.091 mm 0.00079 to 0.0035 in.	0.12 mm 0.0047 in.
Gear Shaft to Bushing  • Gear Shaft  • Bushing	O.D.	14.970 to 14.980 mm 0.58937 to 0.58976 in.	–
	I.D.	15.000 to 15.061 mm 0.59056 to 0.59295 in.	–
Side Plate	Thickness	2.48 to 2.50 mm 0.0977 to 0.0984 in.	2.40 mm 0.094 in.
Hydraulic Cylinder	I.D.	80.05 to 80.15 mm 3.152 to 3.155 in.	80.20 mm 3.157 in.
Hydraulic Arm Shaft	O.D. (LH)	31.925 to 31.950 mm 1.2569 to 1.2578 in.	–
	O.D. (RH)	29.925 to 29.950 mm 1.1782 to 1.1791 in.	–

9Y1210855HYS0002US0

### 3. TIGHTENING TORQUES

Tightening torques of screws, bolts and nuts on the table below are especially specified.  
 (For general use screws, bolts and nuts: Refer to "5. TIGHTENING TORQUES" on page G-13.)

Item	N·m	kgf·m	lbf·ft
ROPS mounting nut	124 to 147	12.6 to 15.0	91.2 to 108
Fuel tank stay mounting bolt and nut	48 to 55	4.9 to 5.7	36 to 41
Fender bracket mounting bolt	124 to 147	12.6 to 15.0	91.2 to 108
Hydraulic cylinder block mounting bolt	40 to 44	4.0 to 4.5	29 to 32
Hydraulic pump mounting bolt (M6)	7.9 to 9.3	0.80 to 0.95	5.8 to 6.8
Hydraulic pump mounting bolt (M8)	18 to 20	1.8 to 2.1	13 to 15

9Y1210855HYS0003US0

# 4. CHECKING, DISASSEMBLING AND SERVICING

## [1] CHECKING AND ADJUSTING

### (1) Relief Valve

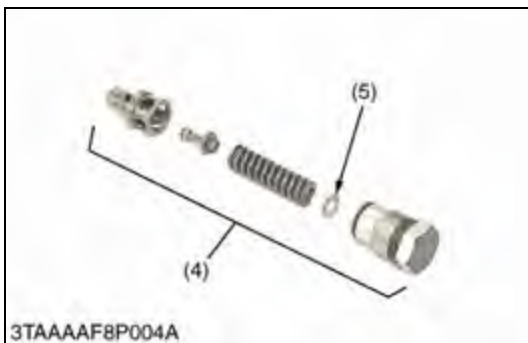

#### Relief Valve Setting Pressure

1. Remove the hydraulic pipe (1).
2. Install the hose and adaptor A (3) with pressure gauge (2).
3. Start the engine and set at maximum speed.
4. Move the control lever all way up to operate the relief valve and read the gauge.
5. If the pressure is not within the factory specifications, adjust with the adjusting shim (5).

Relief valve setting pressure	Factory specification	12.3 to 12.7 MPa 125 to 130 kgf/cm <sup>2</sup> 1780 to 1840 psi
-------------------------------	-----------------------	--

#### Condition

- Engine speed: Maximum
- Oil temperature: 45 to 55 °C (113 to 131 °F)

#### (Reference)

- Thickness of shim (5):  
0.1 mm (0.004 in.)  
0.2 mm (0.008 in.)  
0.4 mm (0.02 in.)
- 0.269 MPa (2.74 kgf/cm<sup>2</sup>, 39.0 psi) pressure is increased whenever the thickness of adjusting shim is increased by 0.1 mm (0.004 in.).

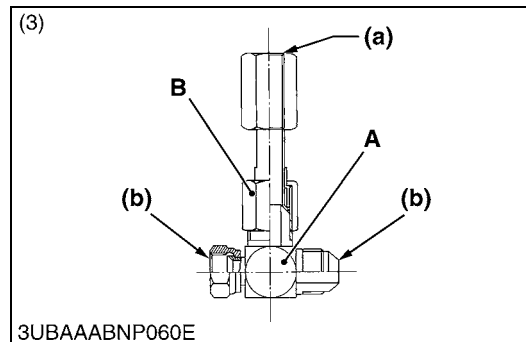

- (1) Hydraulic Pipe
- (2) Pressure Gauge
- (3) Adaptor Tee, Swivel (9/16-18)
- (4) Relief Valve
- (5) Shim

- A: Adaptor Tee, Swivel (9/16-18)
- B: Adaptor B
- (a) Connect Pressure Gauge
- (b) Connect Hydraulic Hose

9Y1210855HYS0004US0



## (2) Pump and Priority Valve



### Checking Power Steering Oil Flow

■ **IMPORTANT**

- Use the instruction with the flowmeter when you use the flowmeter.
  - While testing, do not close the flowmeter loading valve completely.
1. Disconnect the power steering controller hose (Inlet) (1) from the power steering pipe (2).
  2. Fix the inlet flow meter hose to the power steering pipe (2) and the flow meter as shown in the photo.
  3. Fix the flow meter return hose to the transmission fluid filling port and the flow meter as shown in the photo.
  4. Measure the flow volume of power steering.  
The flow volume of pump is 8 L (2.1 U.S.gals, 1.8 Imp.gals) or higher and verify the content below when the engine revolution is 1500 min<sup>-1</sup> (rpm).
  5. If the flow volume varies from the specification, replace the priority valve then take measurement again.
  6. After measuring the flow volume, remove the flow meter then reassembling the hydraulic pipe to the original position.

**Condition**

- Engine speed:  
1500 min<sup>-1</sup> (rpm)
- Oil temperature:  
45 to 55 °C (113 to 131 °F)

Power steering oil flow	Factory specification	Above 8.0 L/min. 2.1 U.S.gals/min. 1.8 Imp.gals/min.
-------------------------	-----------------------	---

- (1) Power Steering Controller Hose (Inlet)      (2) Power Steering Pipe

9Y1210855HYS0006US0





**Checking 3-point Hitch Oil Flow**

■ **IMPORTANT**

- Use the instruction with the flowmeter when you use the flowmeter.
- While testing, do not close the flowmeter loading valve completely.

1. Remove the hydraulic pipe behind the hydraulic cylinder and fix the flow meter hose and the flow (meter) inlet as shown in the photo.
2. Remove the transmission fluid filling plug, then fix the flow meter hose and the flowmeter (outlet).
3. If the flow volume is insufficient, replace the pump.
4. After measuring the flow volume, remove the flow meter then reassembling the hydraulic pipe to the original position.

3-point hitch oil flow	Factory specification	Above 15.5 L/min. 4.1 U.S.gals/min. 3.4 Imp.gals/min.
------------------------	-----------------------	--

**(Reference)**

- Total oil flow of hydraulic pump is calculated with adding the value of power steering oil flow and 3-point hitch oil flow.

Pump capacity	Factory specification	23.5 L/min. 6.2 U.S.gals/min. 5.2 Imp.gals/min.
---------------	-----------------------	---

**Condition**

- Engine speed:  
Maximum
- Oil temperature:  
45 to 55 °C (113 to 131 °F)

9Y1210855HYS0026US0

### (3) Mower Lift Linkage

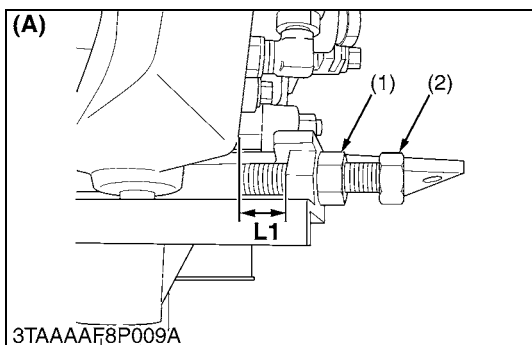

#### Mower Lift Linkage

After reassembling the mower lift linkage, be sure to adjust it as follows.

1. Check the lift arm free play.
2. Loosen the adjusting nut (1) and start the engine.
3. Move the hydraulic control lever to **Lift** position until the relief valve operating. (**Uppermost** position)
4. Adjusting bolt (2) until the clearance between stopper and mower rear link **LH** gets 0 to 0.5 mm (0 to 0.01 in.).
5. Secure the lock nut (1).

Clearance "L2"	Factory specification	0 to 0.5 mm 0 to 0.01 in.
----------------	-----------------------	------------------------------

#### (Reference)

Length "L1"	Factory specification	17 mm 0.67 in.
-------------	-----------------------	-------------------

- (1) Nut
- (2) Bolt

(A) Upper View  
L1: Length  
L2: Clearance

9Y1210855HYS0007US0

## [2] PREPARATION

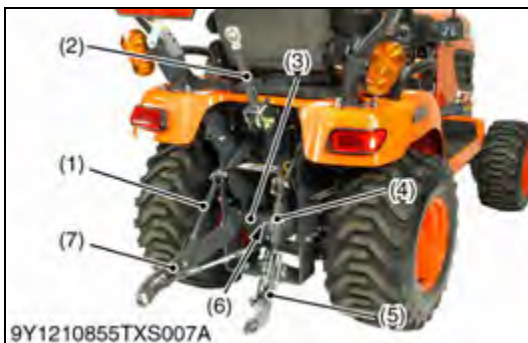
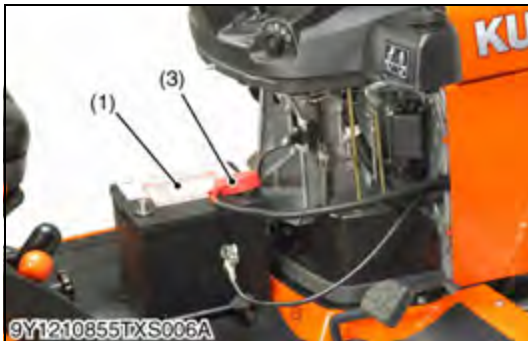

### Battery

#### ⚠ CAUTION

- When disconnecting the battery cables, disconnect the negative cable from the battery first. When connecting, connect the positive cable to the battery first.

1. Remove the under panel.
2. Disconnect the negative cable (2) from the battery (1).
3. Disconnect the positive cable (3) from the battery (1) and remove the battery (1).

- (1) Battery (3) Positive Cable  
(2) Negative Cable

9Y1210855TXS0015US0

### Lift Rod and Lower Link

1. Remove the top link (2).
2. Remove the stopper pin (6) and remove the check chain plate (3).
3. Move the bushes (8) to inside.
4. Move the shaft (9) to right side and remove the lower link as a unit.

- (1) Lift Rod LH (6) Stopper Pin  
(2) Top Link (7) Lower Link LH  
(3) Check Chain Plate (8) Bush  
(4) Lift Rod RH (9) Shaft  
(5) Lower Link RH

9Y1210855TXS0016US0

### Roll-Over Protective Structures (ROPS)

1. Disconnect the lead wires from the hazard lamp (2), (4) and turn signal lights (3), (5).
2. Remove the ROPS mounting nuts, and remove the ROPS (1).

#### (When reassembling)

Tightening torque	ROPS mounting nut	124 to 147 N·m 12.6 to 15.0 kgf·m 91.2 to 108 lbf·ft
-------------------	-------------------	--

- (1) ROPS (4) Hazard Lamp RH  
(2) Hazard Lamp LH (5) Turn Signal Light RH  
(3) Turn Signal Light LH

9Y1210855TXS0017US0



**Seat**

1. Disconnect the seat switch connectors.
2. Remove the snap pins (2) to remove the seat (1).

- (1) Seat (2) Snap Pin

9Y1210855TXS0018US0

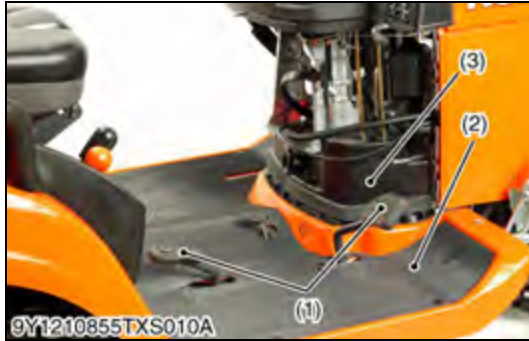

**Speed Control Pedal and Step**

1. Remove the valve covers (3).
2. Remove the speed control pedals (1) and step (2).

- (1) Speed Control Pedal (2) Step (3) Valve Cover

9Y1210855TXS0019US0



**Lever Grips and Fender**

1. Remove the connector from the electric outlet (6).
2. Remove the lowering speed adjusting knob (5) and cutting height adjusting dial knob (4).
3. Remove the lever grips (3).
4. Remove the fender (1).

- (1) Fender (2) Lever Guide (3) Lever Grip (4) Cutting Height Adjusting Dial Knob (5) Lowering Speed Adjusting Knob (6) Electric Outlet

9Y1210855TXS0020US0



**Fuel Tank**

1. Drain the fuel.
2. Disconnect the lead wire from fuel level sensor and fuel hoses from the fuel tank (1).
3. Remove the fuel tank stays (2), (3) and cushions, then remove the fuel tank (1).
4. Remove the PTO cover (4).

**(When reassembling)**

Tightening torque	Fuel tank stay mounting bolt and nut	48 to 55 N·m 4.9 to 5.7 kgf·m 36 to 41 lbf·ft
-------------------	--------------------------------------	---



- (1) Fuel Tank (2) Fuel Tank Stay LH (3) Fuel Tank Stay RH (4) PTO Cover

9Y1210855TXS0021US0



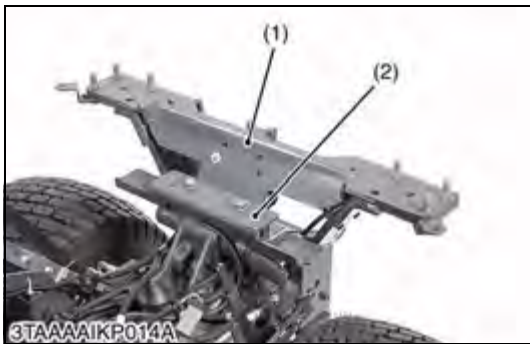

**Fender Center Stay**

1. Remove the fender bracket (2).
2. Remove the fender center stay (1).

**(When reassembling)**

Tightening torque	Fender bracket mounting bolt	124 to 147 N·m 12.6 to 15.0 kgf·m 91.2 to 108 lbf·ft
-------------------	------------------------------	--

(1) Fender Center Stay

(2) Fender Bracket

9Y1210855TXS0022US0



**Mower Linkage and Wire Harness**

1. Disconnect the mower linkage (2).
2. Remove the wire harness clamp and wire harness (1) move to the front side.

(1) Wire Harness

(2) Mower Linkage

9Y1210855HYS0009US0

### [3] SEPARATING

#### (1) Hydraulic Cylinder Block



#### Hydraulic Cylinder Block

1. Remove the hydraulic pipe (1).
2. Remove the hydraulic cylinder block mounting bolt.
3. Remove the hydraulic cylinder block (2).

#### (When reassembling)

Tightening torque	Hydraulic cylinder block mounting bolt	40 to 44 N·m 4.0 to 4.5 kgf·m 29 to 32 lbf·ft
-------------------	--	---

(1) Hydraulic Pipe

(2) Hydraulic Cylinder Block

9Y1210855HYS0010US0

#### (2) Hydraulic Pump

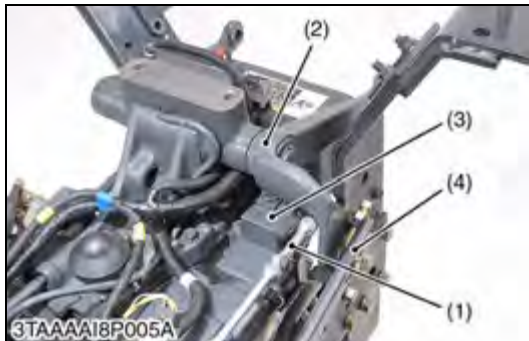

#### Hydraulic Pump

1. Disconnect the mower linkage (4).
2. Remove the lift arm LH (2).
3. Remove the hydraulic pipes (1).
4. Remove the hydraulic pump (3).

Tightening torque	Hydraulic pump mounting bolt (M6)	7.9 to 9.3 N·m 0.80 to 0.95 kgf·m 5.8 to 6.8 lbf·ft
	Hydraulic pump mounting bolt (M8)	18 to 20 N·m 1.8 to 2.1 kgf·m 13 to 15 lbf·ft

#### (When reassembling)

- Since the mounting bolt (5) is installed through the transaxle case to the transmission oil tank, seal the sealing tape to the mounting bolt (5) securely.

(1) Hydraulic Pipe

(5) Bolt (M8) (Through Bolt)

(2) Lift Arm LH

(6) Bolt (M6)

(3) Hydraulic Pump

(7) Bolt (M8)

(4) Mower Linkage

9Y1210855HYS0011US0

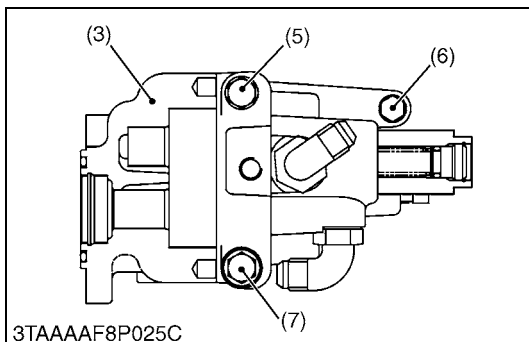

## [4] DISASSEMBLING AND ASSEMBLING

### (1) Hydraulic Cylinder and Control Valve



#### Control Valve

1. Remove the control valve (1).
2. Remove the internal snap ring (4) and draw out the spool (2).

- |                   |                        |
|-------------------|------------------------|
| (1) Control Valve | (3) Plain Washer       |
| (2) Spool         | (4) Internal Snap Ring |

9Y1210855HYS0012US0

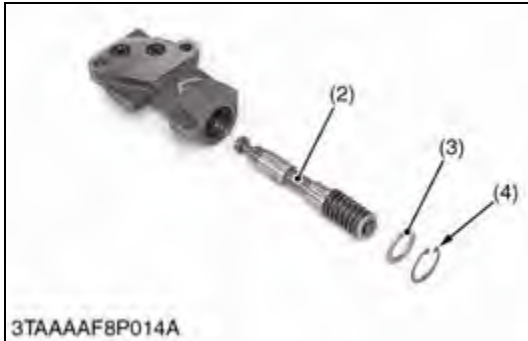

#### Control Valve Lever

1. Pull out the pin (1).
2. Remove the control valve lever (3) and arm (2).

- |         |                         |
|---------|-------------------------|
| (1) Pin | (3) Control Valve Lever |
| (2) Arm |                         |

9Y1210855HYS0013US0

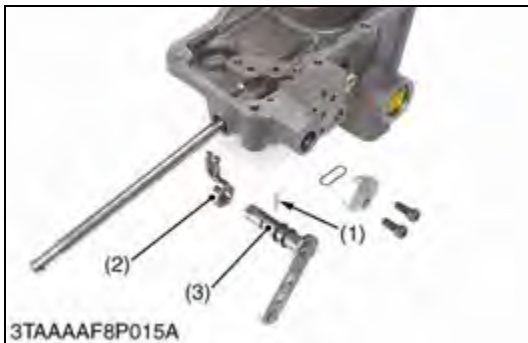

#### Lift Arm, Hydraulic Arm Shaft and Hydraulic Arm

1. Remove the external snap rings (8), (10), and remove the lift arms (2), (7).
2. Draw out the hydraulic arm shaft (4).

#### **(When reassembling)**

- Align the alignment marks of the hydraulic arm (5) and hydraulic arm shaft (4).
- Align the alignment marks of the lift arms (2), (7) and hydraulic arm shaft (4).
- Apply grease to the right and left bushings and O-rings.
- Be careful not to damage the O-ring.

- |                              |                         |
|------------------------------|-------------------------|
| (1) Hydraulic Cylinder Block | (6) O-ring              |
| (2) Lift Arm LH              | (7) Lift Arm RH         |
| (3) O-ring                   | (8) External Snap Ring  |
| (4) Hydraulic Arm Shaft      | (9) Cover               |
| (5) Hydraulic Arm            | (10) External Snap Ring |

9Y1210855HYS0014US0

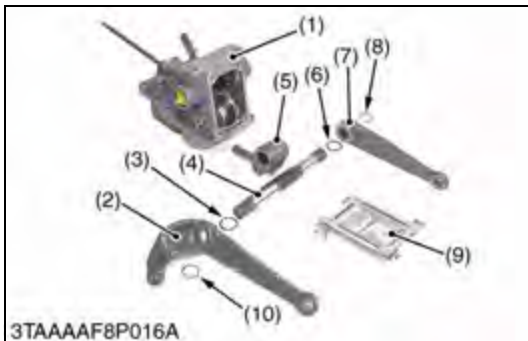



**Hydraulic Piston**

1. Inject the compressed air into the hydraulic cylinder, and remove the hydraulic piston (1).

**(When reassembling)**

- Be careful not to damage the O-ring (3) and back-up ring (2).
- Apply transmission fluid to the O-ring.
- Replace the O-ring if it is damaged, worn or scratched, which may cause oil leakage.

- |                      |            |
|----------------------|------------|
| (1) Hydraulic Piston | (3) O-ring |
| (2) Back-up Ring     |            |

9Y1210855HYS0015US0

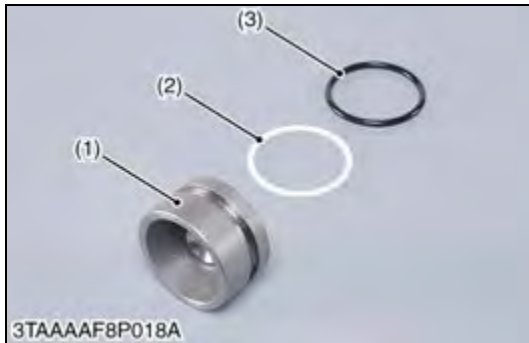

**Lowering Speed Adjusting Valve**

1. Remove the internal snap ring (5) and remove the lowering speed adjusting shaft (6).
2. Remove the ball (2) and spring (1).

**(When reassembling)**

- Be careful not to damage the O-rings.

- |            |                                    |
|------------|------------------------------------|
| (1) Spring | (4) Stopper                        |
| (2) Ball   | (5) Internal Snap Ring             |
| (3) O-ring | (6) Lowering Speed Adjusting Shaft |

9Y1210855HYS0016US0

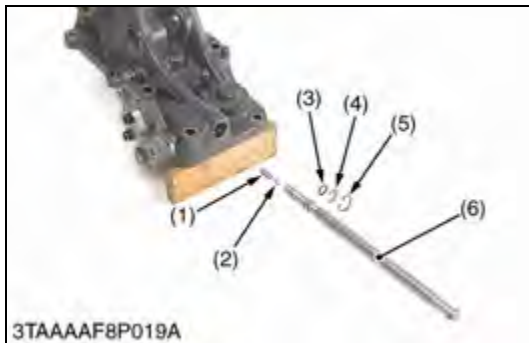



## (2) Mower Lift Linkage

### Disassembling Mower Linkage

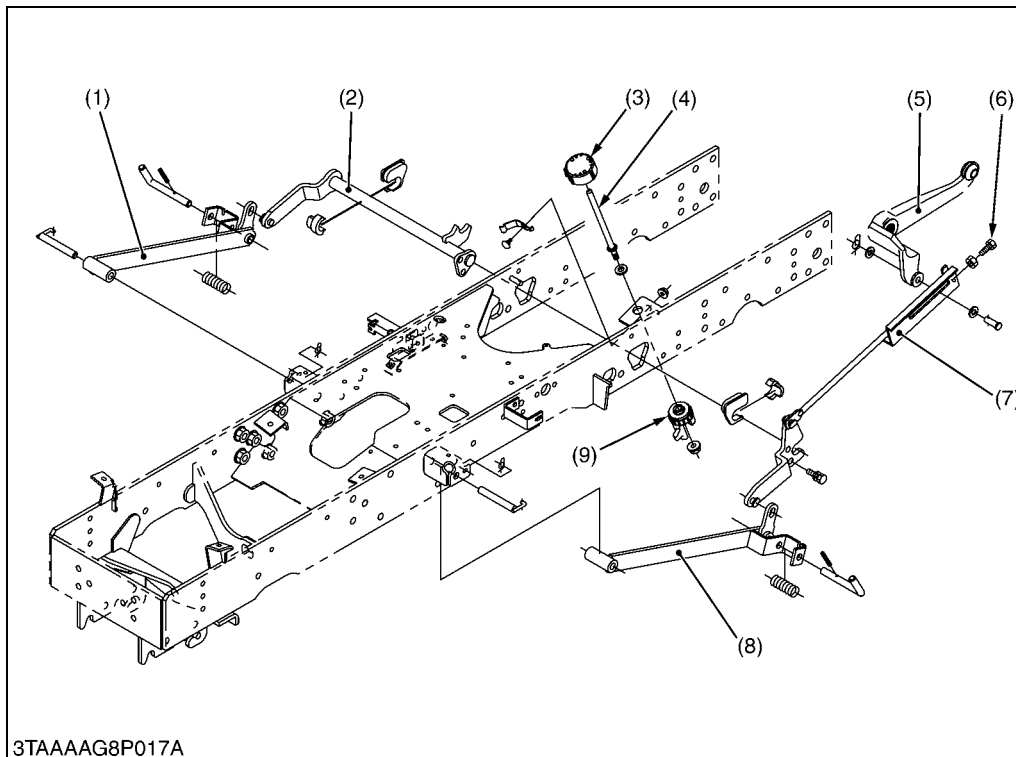

- (1) Mower Rear Link, RH
- (2) Lift Link Rear, RH
- (3) Cutting Height Adjusting Dial Knob
- (4) Cutting Height Adjusting Rod
- (5) Lift Arm, LH
- (6) Link Adjusting Bolt
- (7) Lift Link Rear, LH
- (8) Mower Rear Link, LH
- (9) Adjusting Cam

3TAAAAG8P017A

1. Remove the clevis pin and remove the lift link rear LH (7).
2. Remove the pin and remove the mower rear links (1), (8).
3. Remove both side of boss and remove the lift link rear RH (2).
4. Remove the cutting height adjusting dial knob (3).
5. Remove the nut and remove the adjusting cam (9) and cutting height adjusting rod (4).

#### **(When reassembling)**

- Adjust the length of the link adjusting bolt. (See page 5-S7.)

9Y1210855HYS0017US0

### (3) Control Valve (Front Loader)

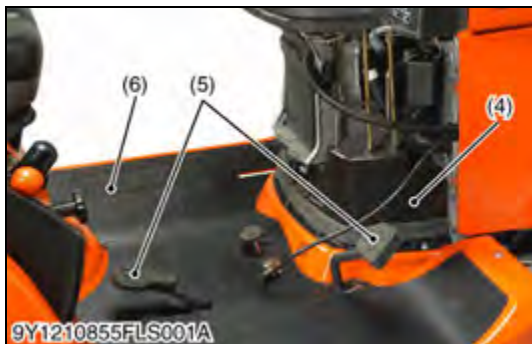

#### Step and Battery

#### **⚠ CAUTION**

- When disconnecting the battery cables, disconnect the negative cable from the battery first. When connecting, connect the positive cable to the battery first.

1. Remove the under panel (1).
2. Disconnect the negative cable (3) from the battery (2).
3. Remove the valve covers (4).
4. Remove the HST pedal (5) and the step (6).

- |                    |                 |
|--------------------|-----------------|
| (1) Under Panel    | (4) Valve Cover |
| (2) Battery        | (5) HST Pedal   |
| (3) Negative Cable | (6) Step        |

9Y1210855HYS0018US0

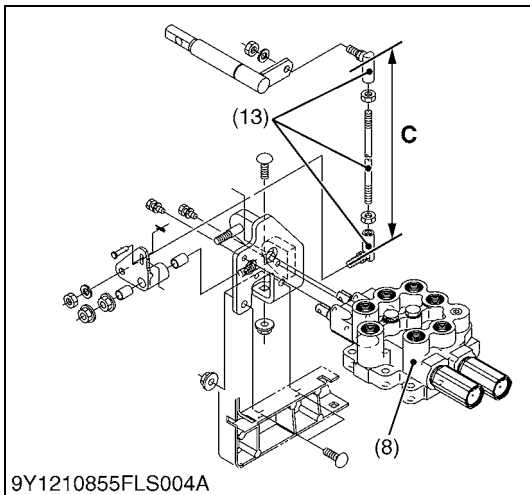
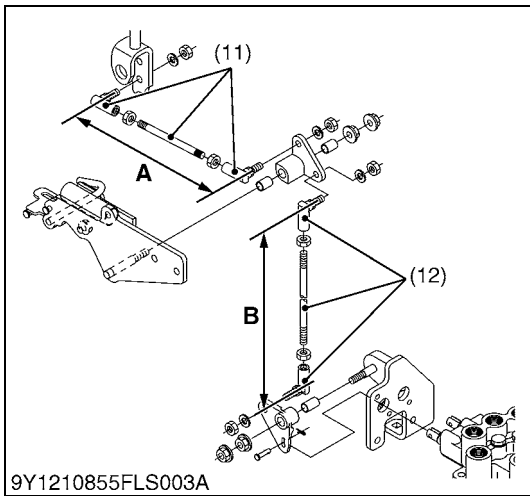
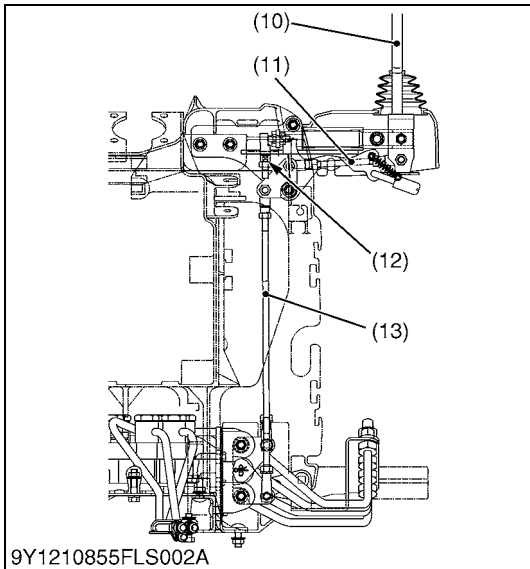
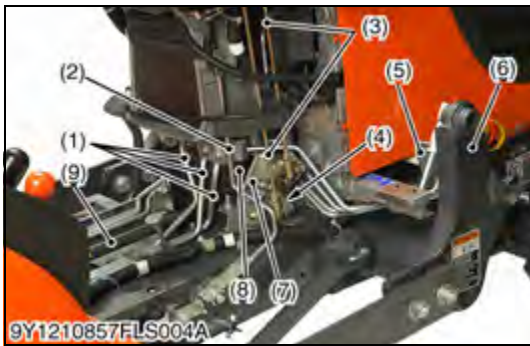

**Control Valve**

1. Remove the loader frame (6).
2. Disconnect the cruise control rod (2).
3. Disconnect the front loader control rods (3).
4. Remove the brake spring.
5. Remove the arms (4) from spool end.
6. Remove the stay bolt (5).
7. Remove the valve stay (7).
8. Disconnect the pipes (1).
9. Remove the control valve (8) with pipes.

**(When reassembling)**

- After reassembling a valve, check for oil leakage by starting up engine.

**■ IMPORTANT**

- **When starting up engine, watch out for the rotating propeller shaft (9).**

**(Reference)**

- When adjusting the length of rods, make the lever come to the neutral position.

**A:** 145 mm (5.71 in.)

**B:** 315 mm (12.4 in.)

**C:** 448 mm (17.6 in.)

- |                              |                                 |
|------------------------------|---------------------------------|
| (1) Pipe                     | (8) Control Valve               |
| (2) Cruise Control Rod       | (9) Propeller Shaft             |
| (3) Front Loader Control Rod | (10) Front Loader Control Lever |
| (4) Arm                      | (11) Rod 1                      |
| (5) Stay                     | (12) Rod 2                      |
| (6) Loader Frame             | (13) Rod 3                      |
| (7) Valve Stay               |                                 |

9Y1210855HYS0019US0

**Disassembling Control Valve**

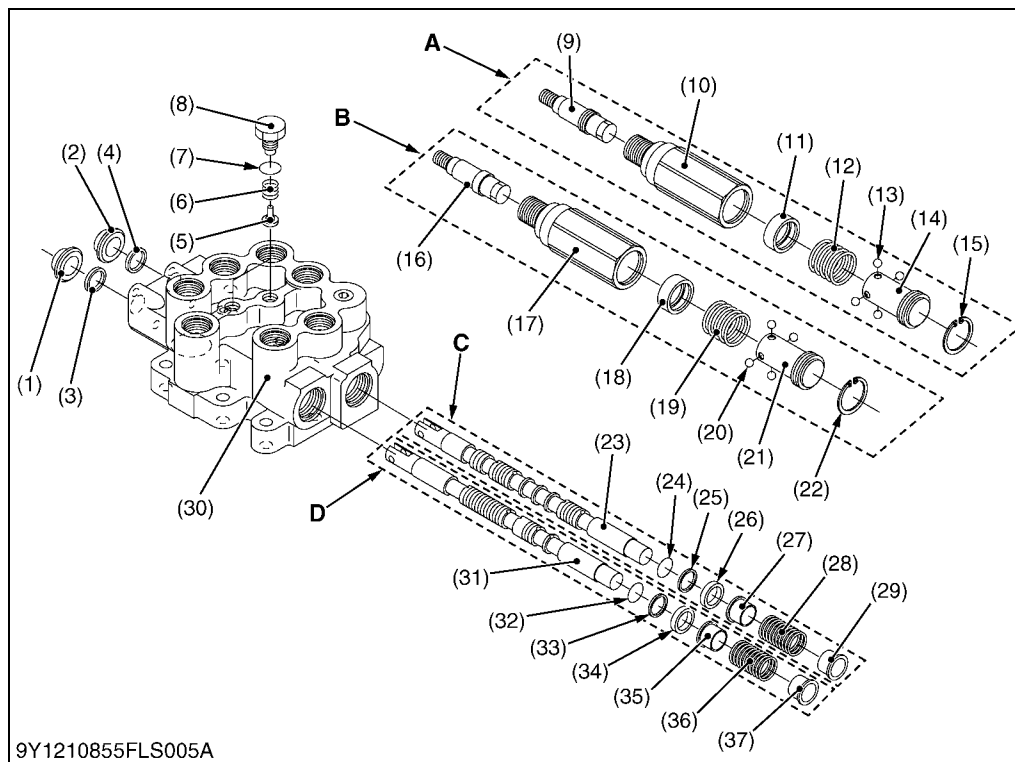

9Y1210855FLS005A

- (1) Seal
  - (2) Seal
  - (3) Dust Seal
  - (4) Dust Seal
  - (5) Load Check Valve
  - (6) Spring
  - (7) O-ring
  - (8) Plug
  - (9) Bolt
  - (10) Plug
  - (11) Seat
  - (12) Spring
  - (13) Ball
  - (14) Stopper
  - (15) Ring
  - (16) Bolt
  - (17) Plug
  - (18) Seat
  - (19) Spring
  - (20) Ball
  - (21) Stopper
  - (22) Ring
  - (23) Spool
  - (24) O-ring
  - (25) Back-up Ring
  - (26) Collar
  - (27) Spring Holder
  - (28) Spring
  - (29) Spring Holder
  - (30) Valve Body
  - (31) Spool
  - (32) O-ring
  - (33) Back-up Ring
  - (34) Collar
  - (35) Spring Holder
  - (36) Spring
  - (37) Spring Holder
- A, C: Boom Control Section**  
**B, D: Bucket Control Section**

1. Remove the plugs (8) and the spring (6) and load check valve (5).
2. Remove the plug (10) and (17) with other parts inside plug "C", "D".
3. Draw out the spools (23), (31) with other component parts "A", "B" from the valve body (30).

**(When reassembling)**

- Clean all parts with a suitable solvent, and dry with a lint-free cloth or air.
- Visually inspect all parts for damage,
- Install the spools to the valve body, not to damage the O-ring.

9Y1210855HYS0020US0

## [5] SERVICING

### (1) Hydraulic Pump



#### Clearance between Tip of Gear Tooth and Casing

1. Measure the gear O.D. with an outside micrometer.
2. Measure the casing I.D. with a cylinder gauge and calculate the clearance.
3. If the clearance exceeds the allowable limit, replace the assembly.

Clearance between tip of gear tooth and casing	Allowable limit	0.15 mm 0.0059 in.
--	-----------------	-----------------------

Gear O.D.	Factory specification	33.520 to 33.530 mm 1.3197 to 1.3200 in.
-----------	-----------------------	---

Case I.D.	Factory specification	33.570 to 33.577 mm 1.3217 to 1.3219 in.
-----------	-----------------------	---

9Y1210855HYS0021US0

#### Clearance between Bushing and Shaft

1. Measure the gear shaft O.D. with an outside micrometer.
2. Measure the bushing I.D. with a cylinder gauge and calculate the clearance.
3. If the clearance exceeds the allowable limit, replace it.

Clearance between bushing and shaft	Factory specification	0.020 to 0.091 mm 0.00079 to 0.0035 in.
	Allowable limit	0.12 mm 0.0047 in.

Shaft O.D.	Factory specification	14.970 to 14.980 mm 0.58937 to 0.58976 in.
------------	-----------------------	---

Bushing I.D.	Factory specification	15.000 to 15.061 mm 0.59056 to 0.59295 in.
--------------	-----------------------	---

9Y1210855HYS0022US0

#### Side Plate Thickness

1. Measure the side plate thickness with an outside micrometer.
2. If the thickness is less than the allowable limit, replace it.

Side plate thickness	Factory specification	2.48 to 2.50 mm 0.0977 to 0.0984 in.
	Allowable limit	2.40 mm 0.094 in.

9Y1210855HYS0023US0

## (2) Hydraulic Cylinder

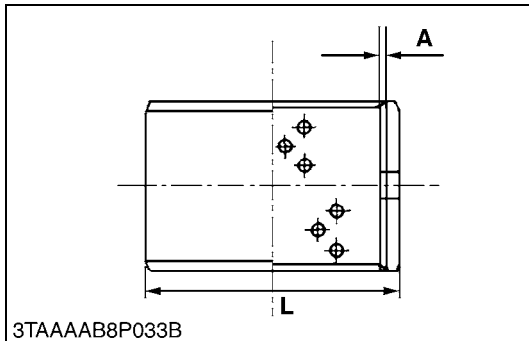

### Hydraulic Cylinder Bore

1. Check the cylinder internal surface for scoring or damage.
2. Measure the cylinder I.D. with a cylinder gauge.
3. If the measurement exceeds the allowable limit, replace the hydraulic cylinder block.

Cylinder I.D.	Factory specification	80.05 to 80.15 mm 3.152 to 3.155 in.
	Allowable limit	80.20 mm 3.157 in.

9Y1210855HYS0024US0

### Hydraulic Arm Shaft Bushing

1. Visually inspect the DX bushings for signs of wear or damage. (The DX bushing tends to show concentrated wear.)
2. If the DX bushing is worn beyond the alloy thickness "A", replace it.

#### (Reference)

Hydraulic arm shaft bushing	Alloy thickness "A"	0.57 mm 0.022 in.
-----------------------------	---------------------	----------------------

Hydraulic arm shaft O.D.	Factory specification	LH	31.925 to 31.950 mm 1.2569 to 1.2578 in.
		RH	29.925 to 29.950 mm 1.1782 to 1.1791 in.

**A:** Alloy Thickness

**L:** Outside Diameter

9Y1210855HYS0025US0

# **6 ELECTRICAL SYSTEM**

# MECHANISM

## CONTENTS

1. WIRING DIAGRAM.....	6-M1
2. STARTING SYSTEM.....	6-M2
[1] MAIN SWITCH POSITION .....	6-M2
[2] SAFETY SWITCH .....	6-M3
[3] OPERATOR PRESENCE CONTROL (OPC).....	6-M4
3. CHARGING SYSTEM.....	6-M5
[1] ELECTRICAL CIRCUIT .....	6-M5
[2] IC REGULATOR (3P CONNECTOR TYPE) .....	6-M6
4. LIGHTING SYSTEM .....	6-M7
5. GAUGES .....	6-M8
[1] ELECTRICAL CIRCUIT .....	6-M8
[2] HOUR AND TACHOMETER .....	6-M9
[3] FUEL LEVEL GAUGE .....	6-M9
[4] WATER TEMPERATURE GAUGE .....	6-M10
6. OTHERS.....	6-M11
[1] DC OUTLET .....	6-M11



# 1. WIRING DIAGRAM

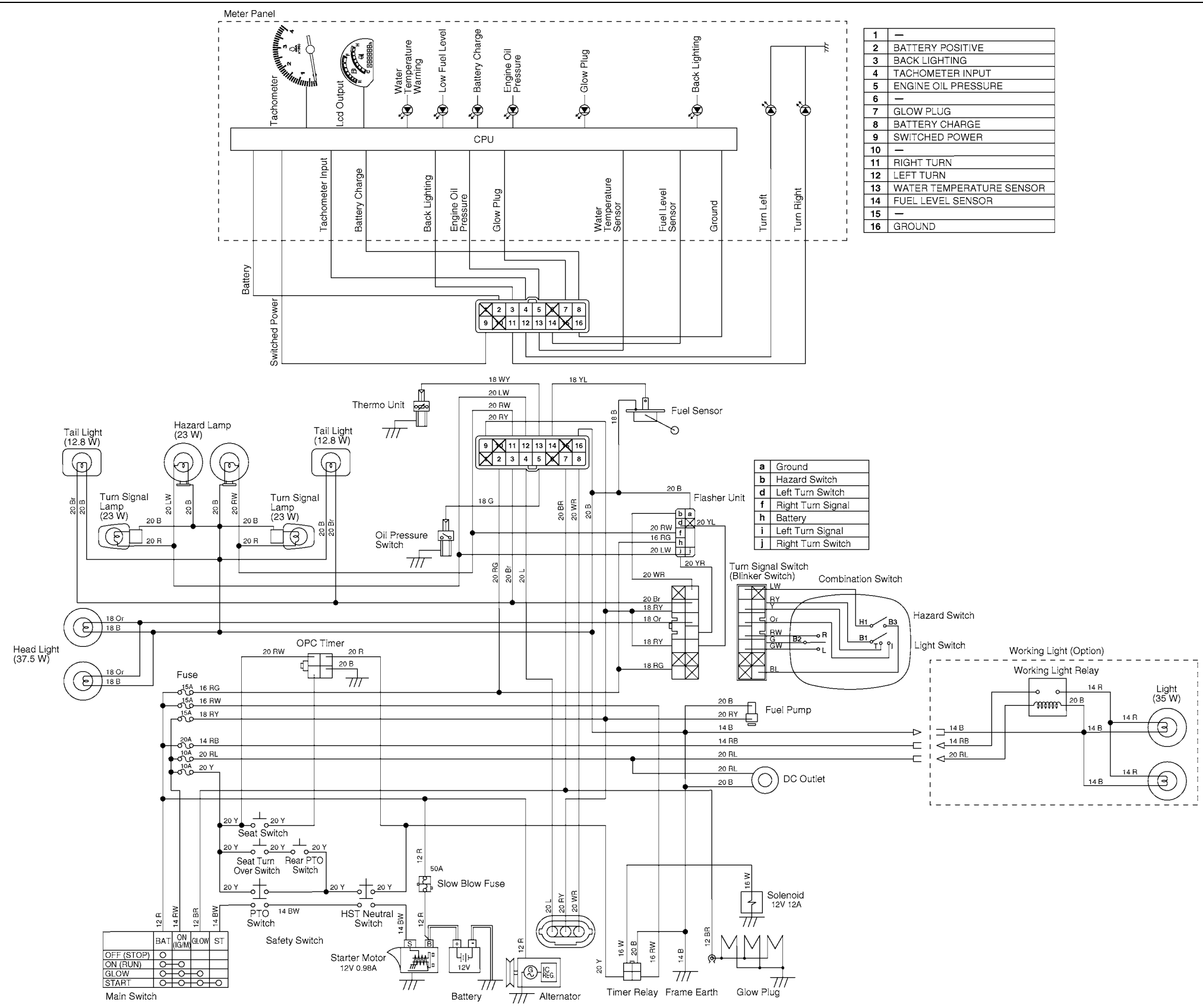

9Y1210855ELT001US

# 2. STARTING SYSTEM

## [1] MAIN SWITCH POSITION

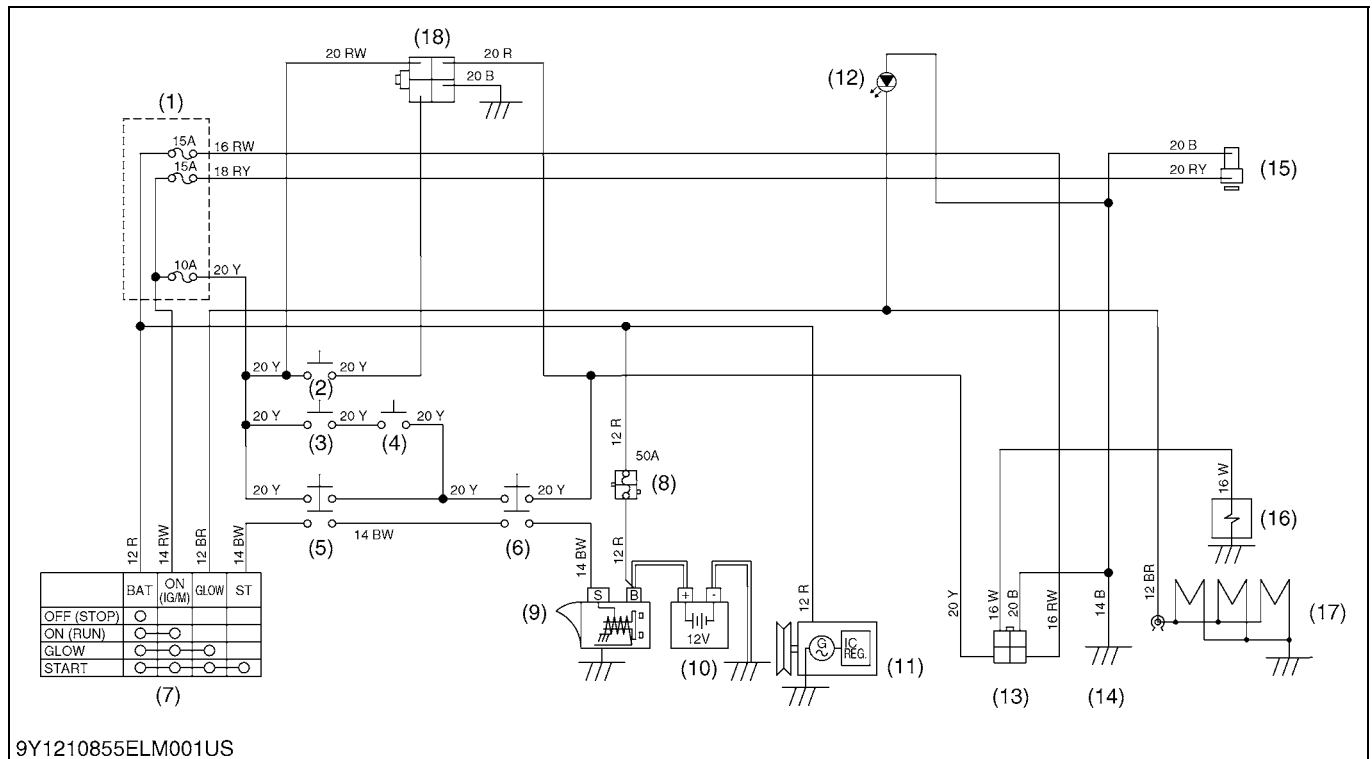

- |                           |                        |                     |                |
|---------------------------|------------------------|---------------------|----------------|
| (1) Fuse                  | (6) HST Neutral Switch | (11) Alternator     | (15) Fuel Pump |
| (2) Seat Switch           | (7) Main Switch        | (12) Glow Indicator | (16) Solenoid  |
| (3) Seat Turn Over Switch | (8) Slow Blow Fuse     | (13) Timer Relay    | (17) Glow Plug |
| (4) Rear PTO Switch       | (9) Starter Motor      | (14) Frame Earth    | (18) OPC Timer |
| (5) PTO Switch            | (10) Battery           |                     |                |

When the main switch (7) is turned to the **GLOW** position, the terminal **BAT** is connected to the terminal **ON** and **AC**. The glow plugs (17) become red-hot, and the preheat indicator lamp also lights on while preheating.

When the main switch is then turned to the **START** position with the safety switches on, the terminal **BAT** is connected to the terminals **GLOW** and **ST**. Consequently, battery (10) current flows to the starter motor (9) and start the engine.

The main switch automatically returns to the **ON** position, the terminal **BAT** is connected only to the terminal **GLOW**, thereby causing the starting circuit to be opened, stopping the starter motor.

When the main switch turned from the **ON** position to the **OFF** position, the fuel cut-off solenoid moves the fuel injection pump control rack to the "**No Fuel Injection**" position and stops the engine.

The BX2670D tractor (with the OPC timer (18)) equipped the operator presence control (OPC) system which automatically stops the engine in approximately one second when operator stands from the seat while shifting the PTO clutch lever and range gear shift lever.

9Y1210855ELM0002US0

## [2] SAFETY SWITCH

This switch is electrically closed in normal condition (normally closed type). The switch operates as sensor detecting and transmitting the position of HST pedal, PTO lever, independent PTO lever, and seat to engine stop solenoid.

Type of Switch	Safety Switch Name	Number of Switch Contact
Normal open type	Seat switch	1
	Seat turn over switch	1
	PTO shift lever switch	1
	Independent PTO Lever Switch (Rear PTO Switch)	2
	HST pedal neutral switch	2

9Y1210855ELM0003US0

### Lever / Pedal Position, Engine Condition and Switch Condition

No.	Lever / Pedal Position					Engine Condition			
	HST Pedal Neutral switch; Neutral: ON Forward or Reverse: OFF	Independent PTO Lever Switch; Independent PTO engaged: ON Independent PTO disengaged: OFF	PTO Shift Lever Switch; Rear PTO Selected: ON Mid PTO or Mid PTO and Rear PTO Selected: OFF	Operator's Seat Switch; Occupied: ON Off Seat or Vacant: OFF	Seat Turn Over Switch; Normal position: OFF Turn over: ON	Engine Stopping	Engine Starting		
1	Neutral Position: ON	Disengaged: OFF	Rear PTO Selected: ON	On Seat: ON	Normal: OFF	Running	Can Start		
2				Off Seat: OFF	Normal: OFF				
3			Mid PTO or Mid PTO and Rear PTO Selected: OFF	On Seat: ON	Normal: OFF				
4				Off Seat: OFF	Normal: OFF				
5			Engaged: ON	Rear PTO Selected: ON	On Seat: ON			Normal: OFF	Running
6					Off Seat: OFF			Normal: OFF	Turn Over: ON
7		Disengaged: OFF	Rear PTO Selected: ON	On Seat: ON	Normal: OFF	Running			
8				Off Seat: OFF	Normal: OFF	Stop			
9			Mid PTO or Mid PTO and Rear PTO Selected: OFF	On Seat: ON	Normal: OFF	Running			
10				Off Seat: OFF	Normal: OFF	Stop			
11			Engaged: ON	Rear PTO Selected: ON	On Seat: ON	Normal: OFF	Running		
12					Off Seat: OFF	Normal: OFF	Turn Over: ON		
13	Forward (OFF) or Reverse (OFF)	Disengaged: OFF	Rear PTO Selected: ON	On Seat: ON	Normal: OFF	Running			
14				Off Seat: OFF	Normal: OFF	Stop			
15			Mid PTO or Mid PTO and Rear PTO Selected: OFF	On Seat: ON	Normal: OFF	Running			
16				Off Seat: OFF	Normal: OFF	Stop			
17			Engaged: ON	Rear PTO Selected: ON	On Seat: ON	Normal: OFF	Running		
18					Off Seat: OFF	Normal: OFF	Stop		
19		Disengaged: OFF	Rear PTO Selected: ON	On Seat: ON	Normal: OFF	Running			
20				Off Seat: OFF	Normal: OFF	Stop			
21			Mid PTO or Mid PTO and Rear PTO Selected: OFF	On Seat: ON	Normal: OFF	Running			
22				Off Seat: OFF	Normal: OFF	Stop			
23			Engaged: ON	Rear PTO Selected: ON	On Seat: ON	Normal: OFF	Running		
24					Off Seat: OFF	Normal: OFF	Turn Over: ON		

9Y1210855ELM0004US0

### [3] OPERATOR PRESENCE CONTROL (OPC)

The BX Tractor equips operator presence control (OPC) system which automatically stops the engine when operator stands up from the operator's seat while shifting the PTO lever or the speed control pedal.

Tractor without the OPC timer stops quickly and tractor with the OPC timer stops in approximately one second when standing up from the seat.

9Y1210855ELM0005US0

#### Electrical Circuit (Tractor with OPC Timer)

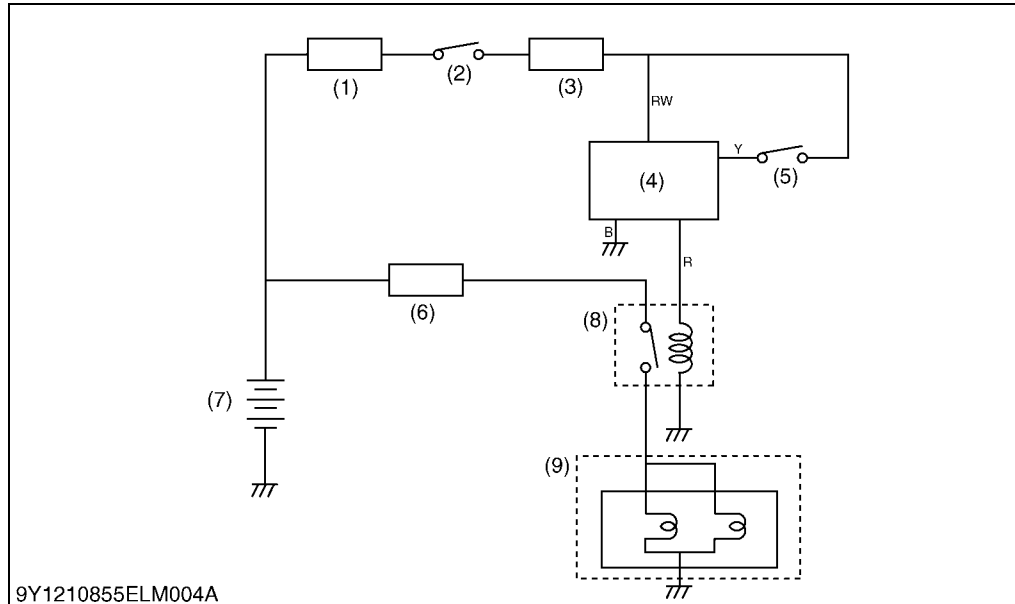

- (1) Slow Blow Fuse
- (2) Main Switch
- (3) Fuse (10 A)
- (4) OPC Timer
- (5) Seat Switch (From Seat Switch **ON** or **OFF**)
- (6) Fuse (15 A)
- (7) Battery
- (8) Engine Stop Solenoid Timer Relay
- (9) Engine Stop Solenoid

9Y1210855ELM004A



General electrical circuit of the tractor OPC timer is shown in the figure.

1. When sitting on the operator's seat in the state of the main switch **"ON"**, the battery voltage passes to the seat switch and the OPC timer (4), and keep the solenoid relay (8).
2. When standing up from the operator's seat, the circuit from the seat switch to the OPC timer is cut. However, if the PTO lever (or the speed control pedal) are set at **"Neutral"** position, the circuit from the battery to the solenoid relay (8) is formed with the PTO switch (or HST switch).
3. When standing up from the operator's seat while shifting the levers, the circuit from the battery to the solenoid relay (8) is cut, and the engine is stopped by function of the solenoid (9).

#### ■ Seat Switch

The seat switch has two positions.

When the operator's seat is occupied, the switch contact point is at **"ON"** position. When the operator's seat is not occupied, its contact point is at **"OFF"** position.

#### ■ OPC Timer

OPC timer is located electrically at between the seat switch (5) and the solenoid relay (8).

When the current supply from the seat switch (5) is cut, the OPC timer (4) adopted for the OPC system has kept the state of **"ON"** position for approximately one second.

9Y1210855ELM0006US0

# 3. CHARGING SYSTEM

## [1] ELECTRICAL CIRCUIT

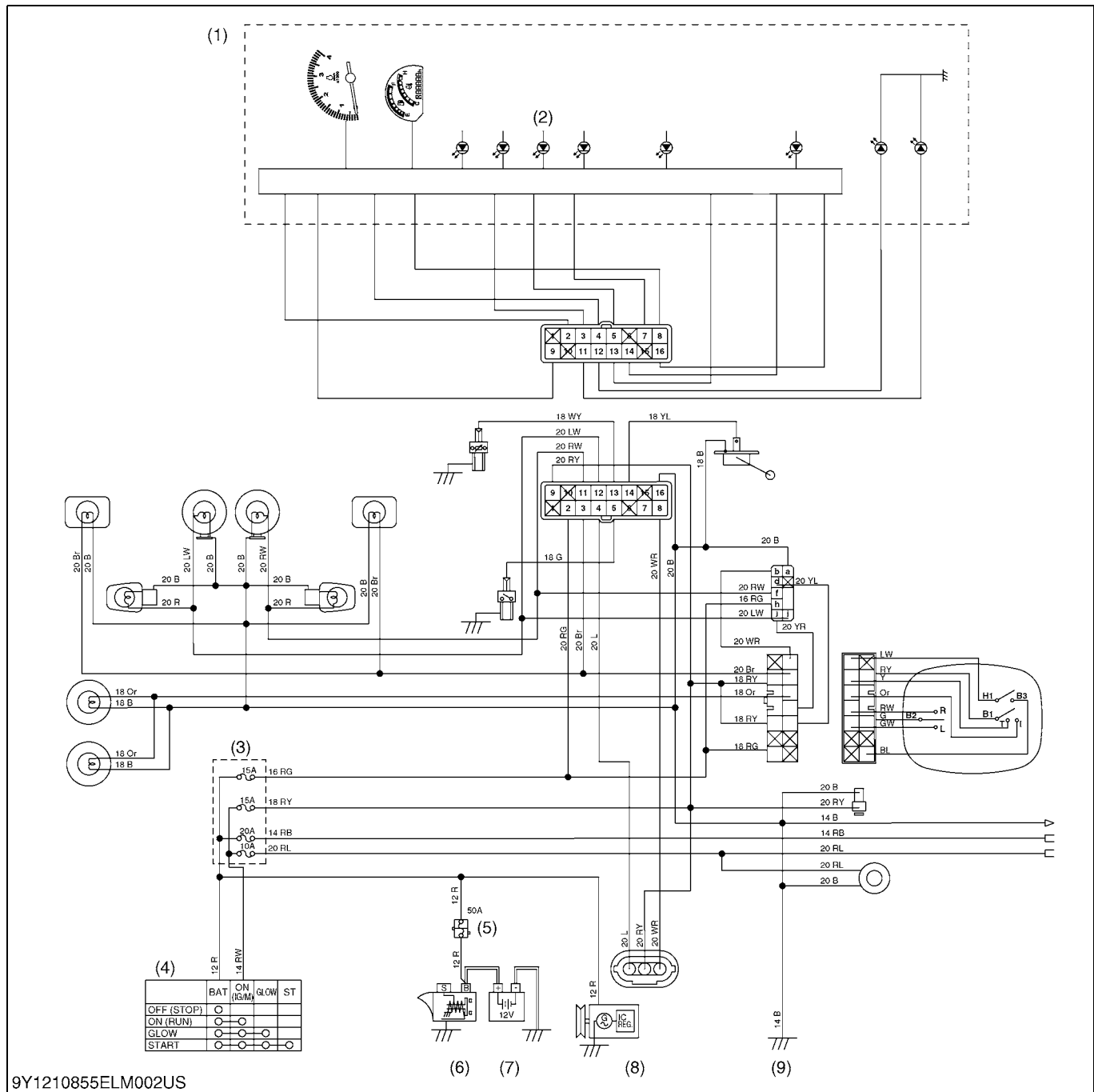

9Y1210855ELM002US

- (1) Meter Panel
- (2) Battery Charge Indicator
- (3) Fuse
- (4) Main Switch
- (5) Slow Blow Fuse
- (6) Starter Motor
- (7) Battery
- (8) Alternator
- (9) Frame Earth

The charging system supplies electric power for various electrical devices and also charges the battery while the engine runs.

9Y1210855ELM0007US0

## [2] IC REGULATOR (3P CONNECTOR TYPE)

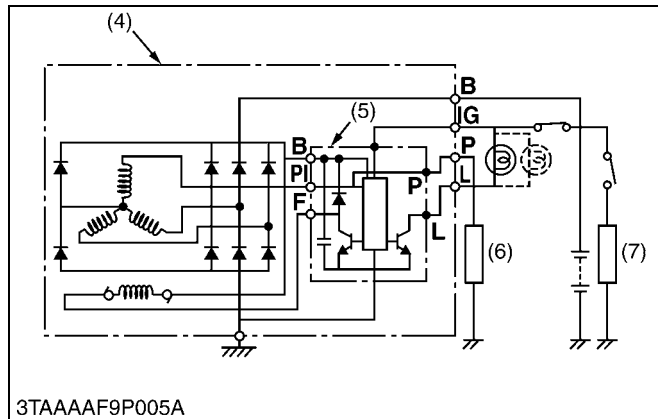
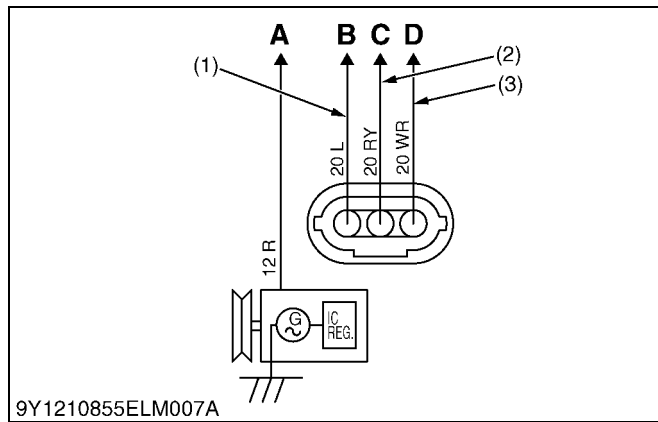

**3P** connector is connected to the IC regulator. **3P** connector consists of three leads, L (Blue) lead (1), RY (Red / Yellow) lead (2), and WR (White / Red) lead (3).

L (Blue) lead (1) is a lead to transmit the pulse from the alternator to hour meter and tachometer. When turning on the main switch to "**ON**" position, the hour meter indicates operated hours.

While the engine runs, the tachometer indicates the present engine revolutions.

RY (Red / Yellow) lead (2) is a lead to chassis.

WR (White / Red) lead (3) is a lead to the charge lamp.

- (1) L (Blue) Lead
- (2) RY (Red / Yellow) Lead
- (3) WR (White / Red) Lead
- (4) Alternator Assembly
- (5) IC Regulator
- (6) Load
- (7) Load

- A: To the Battery**
- B: To Hour Meter and Tachometer**
- C: To Main Switch**
- D: To Charge Indicator**

9Y1210855ELM0008US0

# 4. LIGHTING SYSTEM

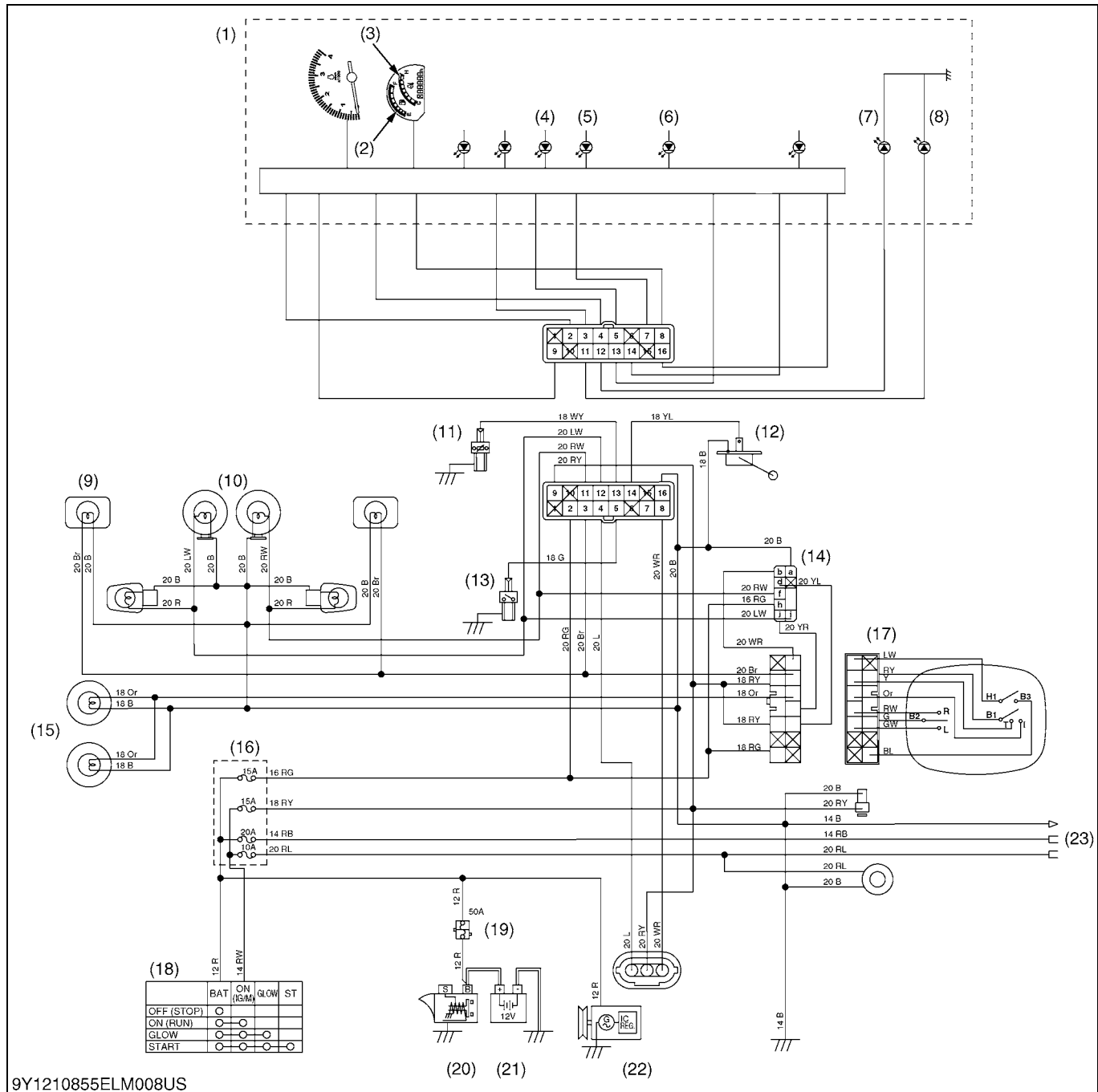

9Y1210855ELM008US

- (1) Meter Panel
- (2) Fuel Gauge
- (3) Water Temperature Gauge
- (4) Battery Charge Indicator
- (5) Oil Pressure Lamp
- (6) Glow Indicator
- (7) Turn (Left)
- (8) Turn (Right)
- (9) Tail Light (12.8 W)
- (10) Hazard Lamp (23 W)
- (11) Thermo Unit
- (12) Fuel Sensor
- (13) Oil Pressure Switch
- (14) Flasher Unit
- (15) Head Light (37.5 W)
- (16) Fuse
- (17) Combination Switch
- (18) Main Switch
- (19) Slow Blow Fuse
- (20) Starter Motor
- (21) Battery
- (22) Alternator
- (23) Working Light

The lighting system consists of main switch, head light switch, turn signal light switch, hazard switch, head lights, turn signal lights, tail lights, and etc..

9Y1210855ELM0009US0

# 5. GAUGES

## [1] ELECTRICAL CIRCUIT

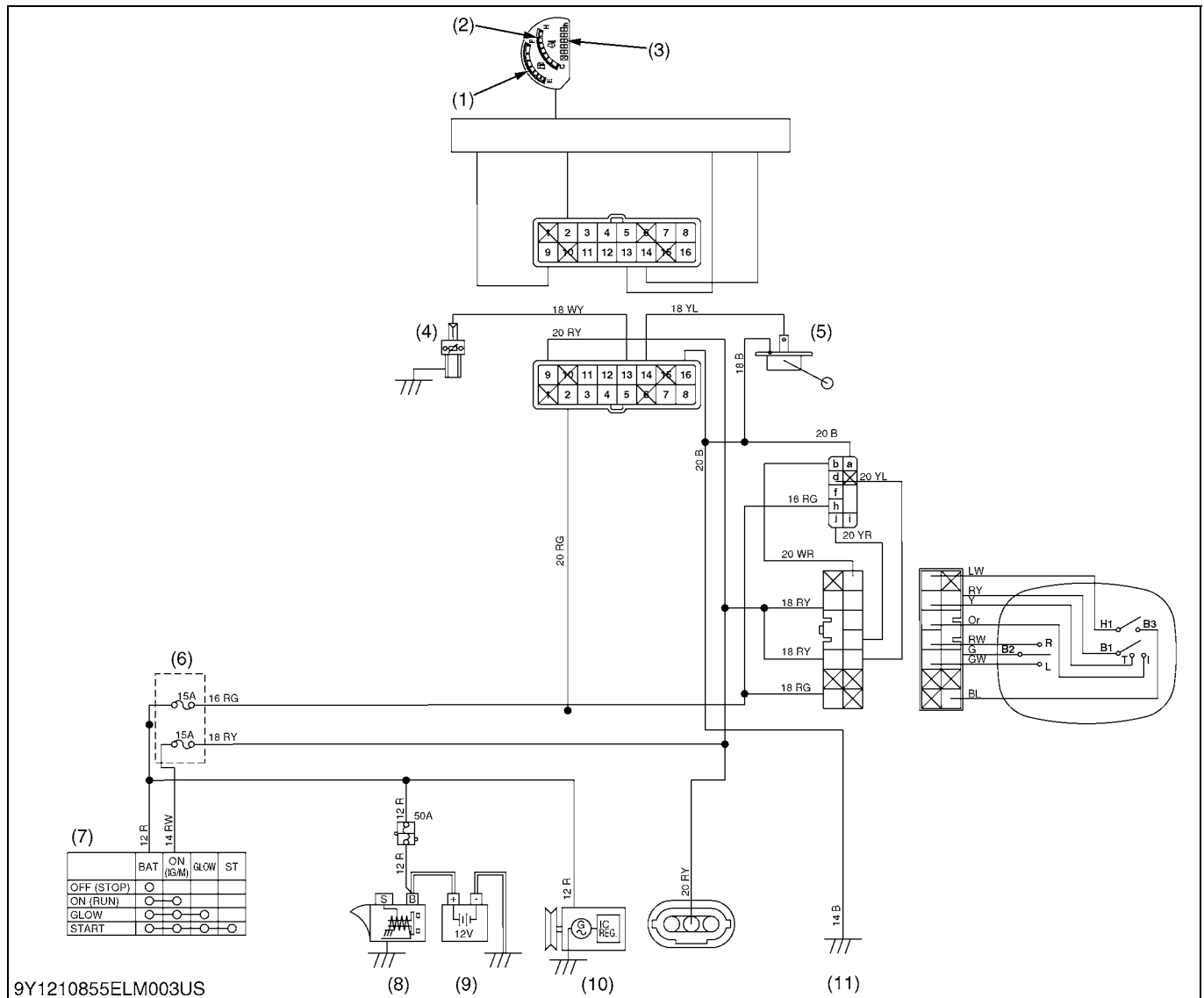

- (1) Fuel Gauge
- (2) Water Temperature Gauge
- (3) Hour Meter
- (4) Thermo Unit
- (5) Fuel Sensor
- (6) Fuse
- (7) Main Switch
- (8) Starter Motor
- (9) Battery
- (10) Alternator
- (11) Frame Earth

The fuel quantity is indicated by the fuel gauge. The coolant temperature is indicated by the water temperature gauge.

The operated hour indicated by the hour meter.

9Y1210855ELM0010US0



## [2] HOUR AND TACHOMETER

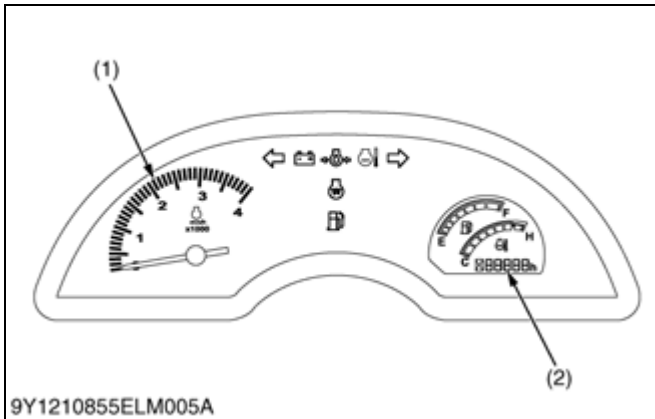

The electrical hour meter and tachometer is equipped on the meter panel.

This meter indicates the operated hours when the main switch is turned to "ON" position.

After starting the engine, this meter indicates the present engine revolution.

The meter picks up the voltage from the IC regulator located in the alternator.

The IC regulator sends a signal of the engine revolution to the meter.

The meter calculates the signal. It changes and indicates the signal to the engine revolution in cooperation with the voltage.

- (1) Tachometer (2) Hour Meter

9Y1210855ELM0011US0

## [3] FUEL LEVEL GAUGE

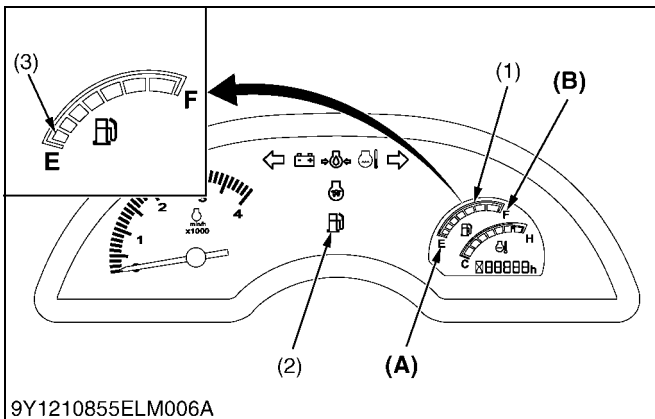

Fuel level gauge and fuel level sensor are connected by the wiring.

Fuel level gauge detects the resistance from the fuel level sensor.

Fuel level gauge indicates the fuel level in the fuel tank.

The relationship between the resistance of the fuel level sensor and the fuel level gauges is as follows.

When the fuel is close to empty level, the low fuel indicator (2) of the Easy Checker™ comes on and the segment K1 (3) of the fuel gauge starts blinking at 1-second intervals.

Resistance of Fuel Level Sensor	Reading on Fuel Level Gauge
Approx. 110 Ω	Empty
Approx. 3 Ω	Full

- (1) Fuel Level Gauge (A) Empty  
 (2) Low Fuel Indicator (B) Full  
 (3) Segment K1

9Y1210855ELM0012US0

## [4] WATER TEMPERATURE GAUGE

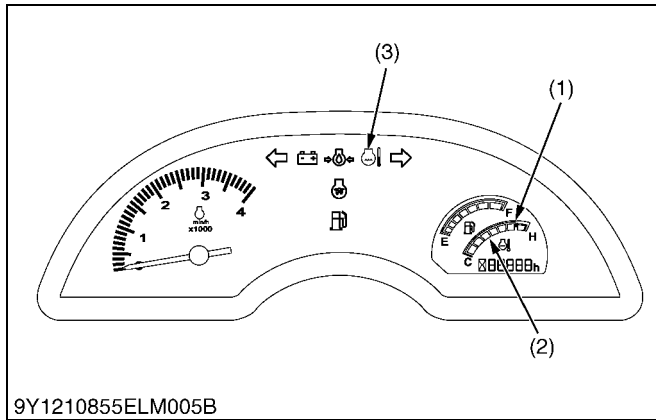

Water temperature gauge is located on the meter panel board.

The water temperature gauge and the thermo unit are connected by the wiring.

The water temperature gauge detects the resistance from the thermo unit.

The water temperature gauge indicates the coolant temperature in the engine cylinder head.

The relationship between the resistance of thermo unit and reading on the water temperature gauge is as follows.

- When the coolant temperature stays at 125 °C (257 °F) for 5 seconds, the indicator on the Easy Checker™ comes on.
- When the coolant temperature stays above 130 °C (266 °F) for 5 seconds, the indicator remains on and all segments of the coolant temperature gauge start blinking at 1-second intervals.
- When the coolant temperature stays below 120 °C (248 °F) for 5 seconds, the indicator turns off.

Resistance of Thermo Unit	Reading on Water Temperature gauge
Approx. 220 Ω	Min.
Approx. 3 Ω	Max.

- (1) Water Temperature Gauge (3) Water Temperature Indicator  
 (2) Segments of Water Temperature

9Y1210855ELM0013US0

## 6. OTHERS

### [1] DC OUTLET



DC outlet is equipped to this machine.  
 The capacity of the DC outlet is 12 V / 120 W.  
 The electrical device as a CD player, a mobile phone battery charger can be used to the DC outlet.  
 The DC outlet (1) consists of the DC outlet body (3) and the cover (4).

- (1) DC Outlet
- (2) Electrical Device
- (3) DC Outlet Body
- (4) Cover

**RL: Red / Blue Lead**  
**B: Black Lead**

9Y1210855ELM0014US0

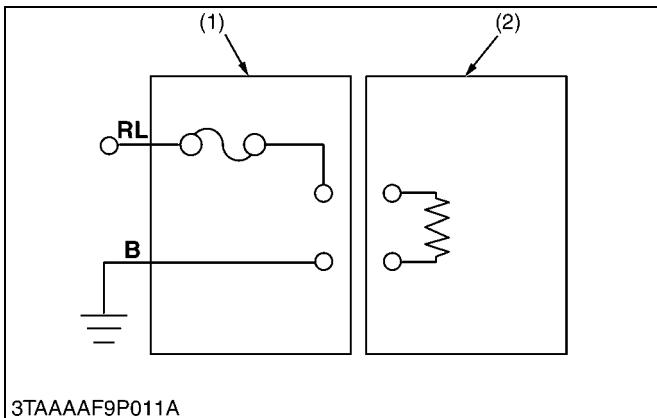

# SERVICING

## CONTENTS

1. TROUBLESHOOTING.....	6-S1
2. SERVICING SPECIFICATIONS.....	6-S5
3. TIGHTENING TORQUES.....	6-S6
4. CHECKING, DISASSEMBLING AND SERVICING.....	6-S7
[1] CHECKING AND ADJUSTING.....	6-S7
(1) Battery.....	6-S7
(2) Main Switch.....	6-S9
(3) Starter.....	6-S10
(4) Glow Plug.....	6-S11
(5) Safety Switch.....	6-S12
(6) Operator Presence Control (OPC) Switch.....	6-S14
(7) Fuel Pump.....	6-S15
(8) Engine Stop Solenoid.....	6-S16
(9) Timer Relay.....	6-S16
(10)Charging System.....	6-S17
(11)Combination Switch.....	6-S17
(12)Gauge.....	6-S23
(13)DC Outlet.....	6-S25
(14)Meter Panel.....	6-S25
[2] DISASSEMBLING AND ASSEMBLING.....	6-S28
(1) Starter.....	6-S28
(2) Alternator.....	6-S29
[3] SERVICING.....	6-S31
(1) Starter.....	6-S31
(2) Alternator.....	6-S33

# 1. TROUBLESHOOTING

## FUSE AND WIRING

Symptom	Probable Cause	Solution	Reference Page
<b>All Electrical Equipments Do Not Operate</b>	Battery discharged or damaged	Recharge or replace	G-26
	Battery positive cable disconnected or improperly connected	Repair or replace	–
	Battery negative cable disconnected or improperly connected	Repair or replace	–
	Slow blow fuse blown	Replace	G-41
<b>Fuse Blown Frequently</b>	Short-circuited	Repair or replace	–

## BATTERY

Symptom	Probable Cause	Solution	Reference Page
<b>Battery Discharges Too Quickly</b>	Battery damaged	Replace	6-S7
	Alternator damaged	Repair or replace	6-S28
	IC Regulator damaged	Replace	–
	Wiring harness disconnected or improperly connected (between battery positive terminal and regulator <b>B</b> terminal)	Repair or replace	–
	Cooling fan belt slipping	Adjust tension	G-29

## STARTING SYSTEM

Symptom	Probable Cause	Solution	Reference Page
<b>Starter Motor Does Not Operate</b>	Battery discharged or damaged	Recharge or replace	G-26
	Slow blow fuse blown	Replace	G-41
	Safety switch improperly adjusted or damaged	Repair or replace	6-S12
	Wiring harness disconnected or improperly connected (between main switch <b>50</b> terminal and safety switches, between safety switches and starter motor, between battery positive terminal and starter motor)	Repair or replace	–
	Starter motor damaged	Repair or replace	6-S28
	Main switch damaged	Replace	6-S9
<b>Engine Does Not Stop When Main Switch Is Turned OFF</b>	Fuse blown (15 A)	Replace	G-41
	Wiring harness disconnected or improperly connected (between main switch <b>AC</b> terminal and engine stop solenoid)	Repair or replace	–
	Engine stop solenoid damaged	Replace	6-S16
	Timer relay damaged	Replace	6-S16
<b>Engine Does Not Start</b>	Engine stop solenoid damaged	Replace	6-S16
	Timer relay damaged	Replace	6-S16

**OPERATOR PRESENCE CONTROL (OPC)**

Symptom	Probable Cause	Solution	Reference Page
<b>Engine Does Not Stop</b>	Solenoid fuse blown (15 A)	Replace	G-41
	Engine stop solenoid relay damaged	Replace	6-S16
	Engine stop solenoid damaged	Replace	6-S16
	PTO shift lever switch damaged	Adjust or replace	6-S12
	HST pedal switch damaged	Adjust or replace	6-S13
	Wiring harness disconnected or improperly connected (between key stop solenoid relay and engine stop solenoid, between engine stop solenoid relay and battery positive terminal)	Repair or replace	–
<b>Starter Motor Does Not Operate</b>	Solenoid fuse blown (15 A)	Replace	G-41
	Engine stop solenoid damaged	Replace	6-S16
	Engine stop solenoid relay damaged	Replace	6-S16
	Seat switch or seat turn over switch damaged	Adjust or replace	6-S14
	PTO shift lever switch damaged	Adjust or replace	6-S12
	HST pedal switch damaged	Adjust or replace	6-S13
	Wiring harness disconnected or improperly connected (between key stop solenoid relay and engine stop solenoid, between engine stop solenoid relay and battery positive terminal)	Repair or replace	–
<b>Engine Stops When HST Pedal Is Pushed in Forward or in Reverse</b>	Wrong wiring of seat switch and seat turn over switch	Proper wiring	–
<b>Engine Suddenly Stops</b>	Seat reverse switch	Adjust the switch position	6-S14

**CHARGING SYSTEM**

Symptom	Probable Cause	Solution	Reference Page
<b>Charging Lamp Does Not Light when Main Switch Is Turned ON</b>	Fuse blown (15 A)	Replace	G-41
	Wiring harness disconnected or improperly connected (between main switch <b>AC</b> terminal and panel board, between panel board and dynamo)	Repair or replace	–
	Alternator damaged	Repair or replace	6-S28
	IC regulator damaged	Replace	–
<b>Charging Lamp Does Not Go Off When Engine Is Running</b>	Wiring harness disconnected or improperly connected (between main switch <b>30</b> terminal and dynamo, between panel board and dynamo)	Repair or replace	–
	Alternator damaged	Repair or replace	6-S28
	IC regulator damaged	Replace	–

**LIGHTING SYSTEM**

Symptom	Probable Cause	Solution	Reference Page
<b>Head Light Does Not Light</b>	Fuse blown (15 A)	Replace	G-41
	Bulb blown	Replace	G-41
	Wiring harness disconnected or improperly connected (between main switch <b>AC</b> terminal and head light switch, between head light switch and head light)	Repair or replace	–
<b>Tail Light Does Not Light</b>	Fuse blown (15 A)	Replace	G-41
	Bulb blown	Replace	G-41
	Wiring harness disconnected or improperly connected (between main switch <b>AC</b> terminal and head light switch, between head light switch and tail light)	Repair or replace	–
<b>Illumination Light Does Not Light</b>	Fuse blown (15 A)	Replace	G-41
	Wiring harness disconnected or improperly connected (between main switch <b>AC</b> terminal and head light switch, between head light switch and illumination light)	Repair or replace	–
<b>Hazard Lamp Does Not Light</b>	Fuse blown (15 A)	Replace	G-41
	Bulb blown	Replace	G-41
	Wiring harness disconnected or improperly connected	Repair or replace	–
	Flasher unit damaged	Replace	6-S21
	Hazard switch damaged	Replace	6-S20
<b>Hazard Indicator Lamp Does Not Light</b>	Wiring harness disconnected or improperly connected	Repair or replace	–
<b>Hazard Lamp Does Not Flicker</b>	Flasher unit damaged	Replace	6-S21
<b>Turn Signal Light Does Not Light</b>	Fuse blown (15 A)	Replace	G-41
	Bulb blown	Replace	G-41
	Wiring harness disconnected or improperly connected	Repair or replace	–
	Flasher unit damaged	Replace	6-S21
	Turn signal switch damaged	Replace	6-S19
<b>Turn Signal Light Indicator Lamp Does Not Light</b>	Wiring harness disconnected or improperly connected (turn signal switch and indicator lamp)	Repair or replace	–
<b>Turn Signal Light Does Not Flicker</b>	Flasher unit damaged	Replace	6-S21
	Turn signal switch damaged	Replace	6-S19
<b>Glow Lamp Does Not Light When Main Switch Is in Pre-heat Position</b>	Battery discharged or damaged	Recharge or replace	G-26
	Slow blow fuse blown	Replace	G-41
	Wiring harness disconnected or improperly connected (between main switch <b>19</b> terminal and pre-heat indicator, between pre-heat indicator and glow plugs)	Repair or replace	–
	Main switch damaged	Replace	6-S9

Symptom	Probable Cause	Solution	Reference Page
<b>Oil Pressure Lamp Lights Up When Engine Is Running</b>	Engine oil pressure too low	Repair engine	–
	Engine oil insufficient	Fill	G-9
	Oil pressure switch damaged	Replace	6-S23
	Short circuit between oil pressure switch lead and chassis	Repair	–
<b>Oil Pressure Lamp Does Not Light When Main Switch Is Turned ON and Engine Is Not Running</b>	Oil pressure switch damaged	Replace	6-S23
	Wiring harness disconnected or improperly connected (between panel board and oil pressure switch)	Repair or replace	–

**GAUGES**

Symptom	Probable Cause	Solution	Reference Page
<b>Fuel Warning Lamp Does Not Light</b>	Fuel gauge damaged	Replace	–
	Fuel level sensor damaged	Replace	6-S23
	Wiring harness disconnected or improperly connected (between fuel gauge and fuel level sensor)	Repair or replace	–
<b>Coolant Temperature Gauge Does Not Function</b>	Coolant temperature gauge damaged	Replace	–
	Coolant temperature sensor damaged	Replace	6-S24
	Wiring harness disconnected or improperly connected (between coolant temperature gauge and coolant temperature sensor)	Repair or replace	–

9Y1210855ELS0001US0



## 2. SERVICING SPECIFICATIONS

Item		Factory Specification	Allowable Limit	
Battery	Voltage	More than 12 V	–	
	Potential Difference	Less than 0.1 V	–	
Glow Plug	Resistance	Approx. 0.9 Ω	–	
Alternator	Charging Current / Alternator Speed	14 to 15 A / 5200 min <sup>-1</sup> (rpm)	–	
	Charging Voltage / Alternator Speed	14 to 15 A / 5200 min <sup>-1</sup> (rpm)	–	
Head Light Switch	Switch <b>OFF</b>	Infinity	–	
	Switch <b>ON</b>	0 Ω	–	
Turn Signal Switch	Switch <b>OFF</b>	Infinity	–	
	Switch <b>R</b>	0 Ω	–	
	Switch <b>L</b>	0 Ω	–	
Hazard Lamp Switch	Switch <b>OFF</b>	Infinity	–	
	Switch <b>ON</b>	0 Ω	–	
Starter • Commutator	O.D.	30.0 mm 1.181 in.	29.0 mm 1.142 in.	
	Difference of O.D.'s	Less than 0.02 mm 0.0008 in.	0.05 mm 0.0020 in.	
	• Mica	Undercut	0.50 to 0.80 mm 0.0197 to 0.0315 in.	0.20 mm 0.0079 in.
	• Brush	Length	14.0 mm 0.551 in.	9.0 mm 0.354 in.
Alternator	No-load Voltage	More than 14 V	–	
	• Starter	Resistance	Less than 1.0 Ω	–
	• Rotor	Resistance	2.9 Ω	–
	• Slip Ring	O.D.	14.4 mm 0.567 in.	14.0 mm 0.551 in.
	• Brush	Length	10.5 mm 0.413 in.	8.4 mm 0.331 in.
Hand Throttle Lever	Operating Force	89.0 to 111 N 9.08 to 11.3 kgf 20 to 25 lbf	–	

### 3. TIGHTENING TORQUES

Tightening torques of screws, bolts and nuts on the table below are especially specified.  
(For general use screws, bolts and nuts: Refer to "5. TIGHTENING TORQUES" on page G-13.)

Item	N·m	kgf·m	lbf·ft
Starter <b>B</b> terminal nut	5.9 to 11.8	0.6 to 1.2	4.3 to 8.7
Pulley nut	58.4 to 78.9	5.95 to 80.5	43.1 to 58.2

9Y1210855ELS0003US0

# 4. CHECKING, DISASSEMBLING AND SERVICING

## [1] CHECKING AND ADJUSTING



### CAUTION

- To avoid accidental short circuit, be sure to attach the positive cable to the positive terminal before the negative cable is attached to the negative terminal.
- Never remove the battery cap while the engine is running.
- Keep electrolyte away from eyes, hands and clothes. If you are splattered with it, wash it away completely with water immediately.
- Keep open sparks and flames away from the battery at all times. Hydrogen gas mixed with oxygen becomes very explosive.

### IMPORTANT

- If the machine is to be operated for a short time without battery (using a slave battery for starting), use additional current (lights) while engine is running and insulate terminal of battery. If this advice is disregarded, damage to alternator and regulator may result.

9Y1210855ELS0004US0

## (1) Battery



### Battery Voltage

1. Stop the engine and turn the main switch **OFF**.
2. Connect the COM (-) lead of the voltmeter to the battery's negative terminal post and the (+) lead to the positive terminal post, and measure the battery voltage.
3. If the battery voltage is less than the factory specification, check the battery specific gravity and recharge the battery.

Battery voltage	Factory specification	More than 12 V
-----------------	-----------------------	----------------

9Y1210855ELS0005US0

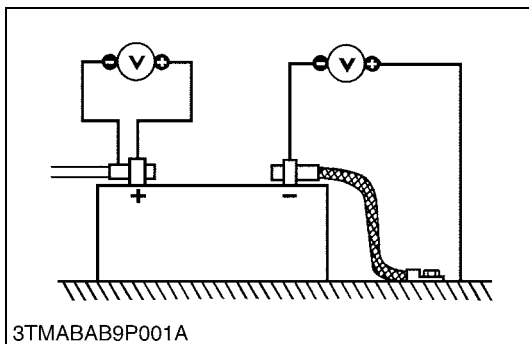

3TMABAB9P001A

### Battery Terminal Connection

1. Turn the main switch **ON**, and turn on the head light.
2. Measure the voltage with a voltmeter across the battery's positive terminal post and the cable terminal, and the voltage across the battery's negative terminal post and the chassis.
3. If the measurement exceeds the factory specification, clean the battery terminal posts and cable clamps, and tighten them firmly.

Potential difference	Factory specification	Less than 0.1 V
----------------------	-----------------------	-----------------

9Y1210855ELS0006US0

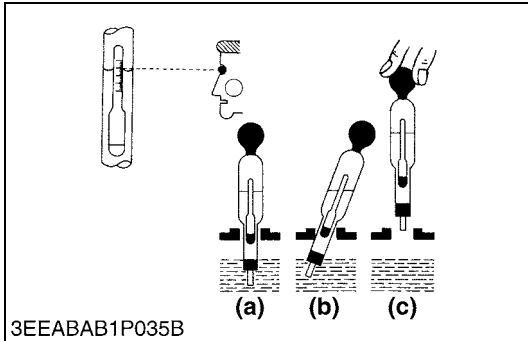
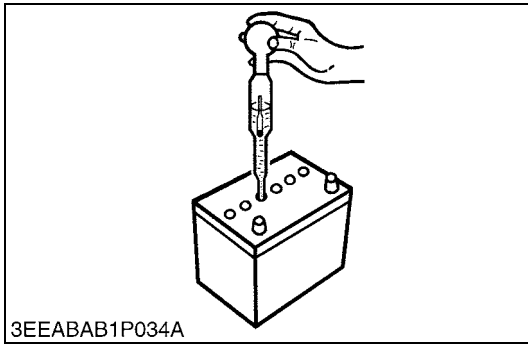

**Battery Specific Gravity**

1. Check the specific gravity of the electrolyte in each cell with a hydrometer.
2. When the electrolyte temperature differs from that at which the hydrometer was calibrated, correct the specific gravity reading following the formula mentioned in **(Reference)**.
3. If the specific gravity is less than 1.215 (after it is corrected for temperature), charge or replace the battery.
4. If the specific gravity differs between any two cells by more than 0.05, replace the battery.

■ **NOTE**

- **Hold the hydrometer tube vertical without removing it from the electrolyte.**
- **Do not suck too much electrolyte into the tube.**
- **Allow the float to move freely and hold the hydrometer at eye level.**
- **The hydrometer reading must be taken at the highest electrolyte level.**

**(Reference)**

- Specific gravity slightly varies with temperature. To be exact, the specific gravity decreases by 0.0007 with an increase of 1 °C (0.0004 with an increase of 1 °F) in temperature, and increases by 0.0007 with a decreases of 1 °C (0.0004 with a decrease of 1 °F).

Therefore, using 20 °C (68 °F) as a reference, the specific gravity reading must be corrected by the following formula:

- Specific gravity at 20 °C = Measured value + 0.0007 × (electrolyte temperature -20 °C)
- Specific gravity at 68 °F = Measured value + 0.0004 × (electrolyte temperature -68 °F)

Specific Gravity	State of Charge
1.260 Sp. Gr.	100 % Charged
1.230 Sp. Gr.	75 % Charged
1.200 Sp. Gr.	50 % Charged
1.170 Sp. Gr.	25 % Charged
1.140 Sp. Gr.	Very Little Useful Capacity
1.110 Sp. Gr.	Discharged

At an electrolyte temperature of 20 °C (68 °F)

(a) Good  
(b) Bad

(c) Bad

9Y1210855ELS0007US0

## (2) Main Switch



### Main Switch Connector Voltage

1. Remove the under cover panel.
2. Disconnect the **4P** connector and remove the main switch (1).
3. Measure the voltage with a voltmeter across the connector **30** (red) terminal and chassis.
4. If the voltage differs from the battery voltage (11 to 14 V), the wiring harness is faulty.

Voltage	Connector <b>30</b> terminal – chassis	Approx. battery voltage
---------	--	-------------------------

(1) Main Switch

9Y1210855ELS0008US0



### Main Switch Continuity

#### 1) Main Switch Key at OFF Position

1. Set the main switch **OFF** position.
2. Measure the resistance with an ohmmeter across the **B** terminal and the **ACC** terminal, **B** terminal and **ST** terminal, **B** terminal and **G** terminal.
3. If infinity is not indicated, the contacts of the main switch are faulty.

Resistance	<b>B</b> terminal – <b>ACC</b> terminal	Infinity
	<b>B</b> terminal – <b>ST</b> terminal	
	<b>B</b> terminal – <b>G</b> terminal	

#### 2) Main Switch Key at ON Position

1. Set the main switch **ON** position.
2. Measure the resistance with an ohmmeter across the **B** terminal and the **ACC** terminal.
3. If 0 ohm is not indicated, the **B – ACC** contact of the main switch are faulty.

Resistance	<b>B</b> terminal – <b>ACC</b> terminal	0 Ω
------------	---	-----

#### 3) Main Switch Key at PREHEAT Position

1. Set and hold the main switch key at the **PREHEAT** position.
2. Measure the resistance with an ohmmeter across the **B** terminal and the **G** terminal, and measure the resistance across the **B** terminal and the **ACC** terminal.
3. If 0 ohm is not indicated, these contacts of the main switch are faulty.

Resistance	<b>B</b> terminal – <b>G</b> terminal	0 Ω
	<b>B</b> terminal – <b>ACC</b> terminal	

#### 4) Main Switch Key at START Position

1. Set and hold the main switch key at the **START** position.
2. Measure the resistance with an ohmmeter across the **B** terminal and the **G** terminal, across the **B** terminal and the **ST** terminal, and across the **B** terminal and the **ACC** terminal.
3. If 0 ohm is not indicated, these contacts of the main switch are faulty.

Resistance	<b>B</b> terminal – <b>G</b> terminal	0 Ω
	<b>B</b> terminal – <b>ST</b> terminal	
	<b>B</b> terminal – <b>ACC</b> terminal	

(1) **B** Terminal  
(2) **ST** Terminal

(3) **ACC** Terminal  
(4) **G** Terminal

9Y1210855ELS0009US0

### (3) Starter

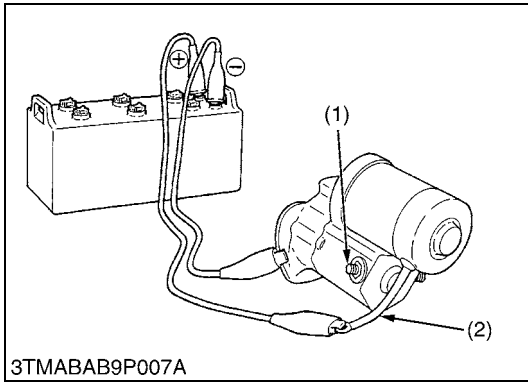

#### Motor Test



- **Secure the starter to prevent it from jumping up and down while testing the motor.**

1. Disconnect the battery negative cable from the battery.
2. Disconnect the battery positive cable and the leads from the starter.
3. Remove the starter from the engine.
4. Disconnect the connecting lead (2) from the starter **C** terminal (1).
5. Connect a jumper lead from the connecting lead (2) to the battery positive terminal post.
6. Connect a jumper lead momentarily between the starter motor housing and the battery negative terminal post.
7. If the motor does not run, check the motor.

(1) **C** Terminal

(2) Connecting Lead

9Y1210855ELS0010US0

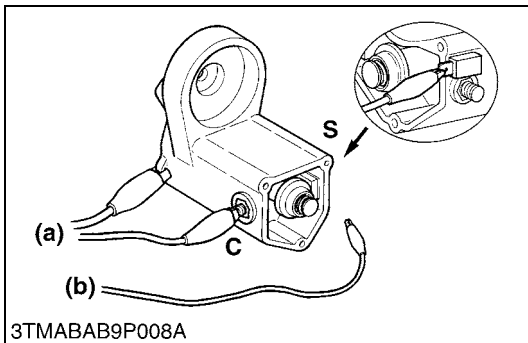

#### Magnet Switch Test (Pull-in, Holding Coils)

1. Remove the motor from the starter housing.
2. Prepare a 6 V battery for the test.
3. Connect jumper leads from the battery negative terminal to the housing and the starter **C** terminal.
4. The plunger should be attracted and the pinion gear should pop out when a jumper lead is connected from the battery positive terminal to the **S** terminal. It's a correct.
5. Disconnect the jumper lead to the starter **C** terminal. Then the pinion gear should remain popped out. It's a correct.

#### ■ IMPORTANT

- **Testing time must be 3 to 5 sec..**

**C:** **C** Terminal

**(a)** To Negative Terminal

**S:** **S** Terminal

**(b)** To Positive Terminal

9Y1210855ELS0011US0

### (4) Glow Plug

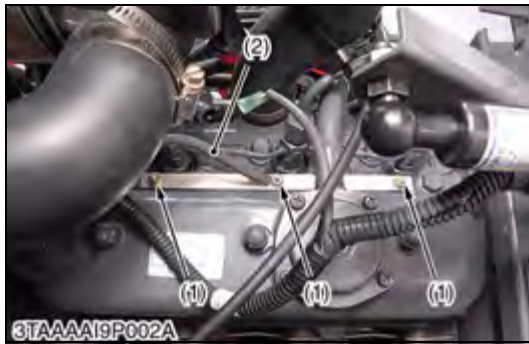

3TAAAA19P002A

#### Lead Terminal Voltage

1. Disconnect the wiring lead (2) from the glow plug (1) after turning the main switch off.
2. Turn the main switch key to the "PREHEAT" position, and measure the voltage between the lead terminal and the chassis.
3. Turn the main switch key to the "START" position, and measure the voltage with a voltmeter between the lead terminal and the chassis.
4. If the voltage at either position differs from the battery voltage, the wiring harness or main switch is faulty.

Voltage (Lead terminal – Chassis)	Main switch key at "PREHEAT"	Approx. battery voltage
	Main switch key at "START"	Approx. battery voltage

(1) Glow Plug

(2) Wiring Lead (Positive)

9Y1210855ELS0012US0

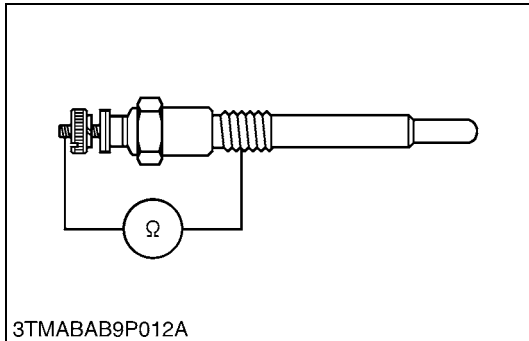

3TMABAB9P012A

#### Glow Plug Continuity

1. Disconnect the lead from the glow plugs.
2. Measure the resistance with an ohmmeter between the glow plug terminal and the chassis.
3. If 0 ohm is indicated, the screw at the tip of the glow plug and the housing are short-circuited.
4. If the factory specification is not indicated, the glow plug is faulty.

Glow plug	Factory specification	Approx. 0.9 Ω
-----------	-----------------------	---------------

9Y1210855ELS0013US0

## (5) Safety Switch

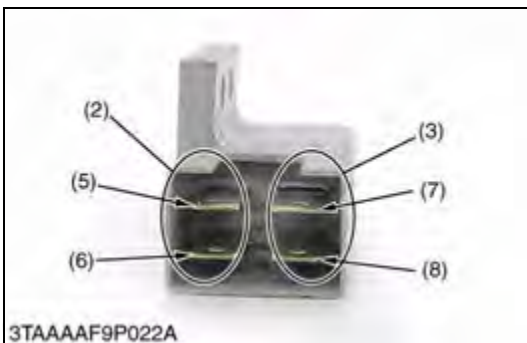
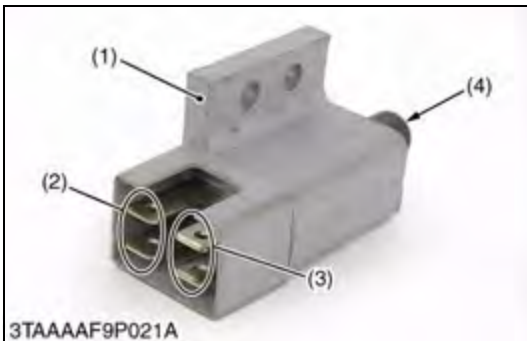

### PTO Shift Lever Switch Continuity

1. Remove the left rear wheel.
2. Remove the PTO shift lever switch (1).
3. Measure the resistance with an ohmmeter across the switch terminals.
4. If the resistance values specified below are not indicated, the safety switch is faulty.

#### **Plunger is pushed into the switch body**

Resistance	1 terminal (5) – 2 terminal (6)	0 Ω
	3 terminal (7) – 4 terminal (8)	0 Ω

#### **Plunger is released**

Resistance	1 terminal (5) – 2 terminal (6)	Infinity
	3 terminal (7) – 4 terminal (8)	Infinity

- |                            |                |
|----------------------------|----------------|
| (1) PTO Shift Lever Switch | (5) 1 Terminal |
| (2) 2P Connector (LH)      | (6) 2 Terminal |
| (3) 2P Connector (RH)      | (7) 3 Terminal |
| (4) Plunger                | (8) 4 Terminal |

9Y1210855ELS0014US0



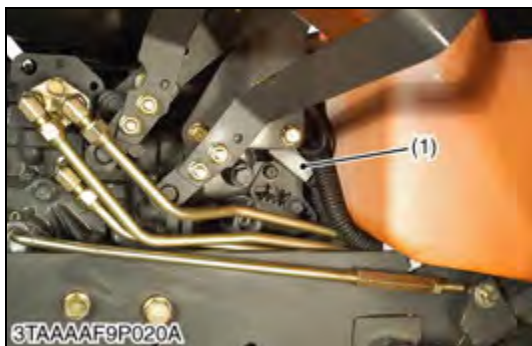

**HST Neutral Switch Continuity**

1. Remove the right rear wheel.
2. Remove the HST neutral switch (1).
3. Measure the resistance with an ohmmeter across the HST neutral switch terminals.
4. If the resistance values specified below are not indicated, the safety switch is faulty.

**Plunger is pushed into the switch body**

Resistance	1 terminal (5) – 2 terminal (6)	0 Ω
	3 terminal (7) – 4 terminal (8)	0 Ω

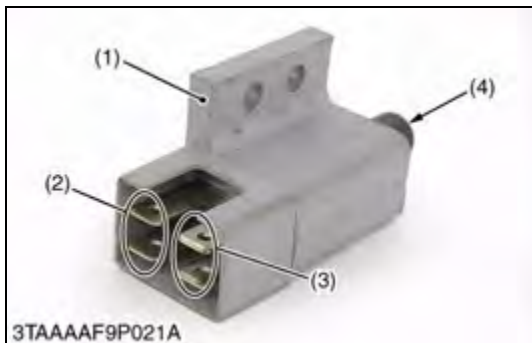

**Plunger is released**

Resistance	1 terminal (5) – 2 terminal (6)	Infinity
	3 terminal (7) – 4 terminal (8)	Infinity

- |                        |                |
|------------------------|----------------|
| (1) HST Neutral Switch | (5) 1 Terminal |
| (2) 2P Connector (LH)  | (6) 2 Terminal |
| (3) 2P Connector (RH)  | (7) 3 Terminal |
| (4) Plunger            | (8) 4 Terminal |

9Y1210855ELS0015US0

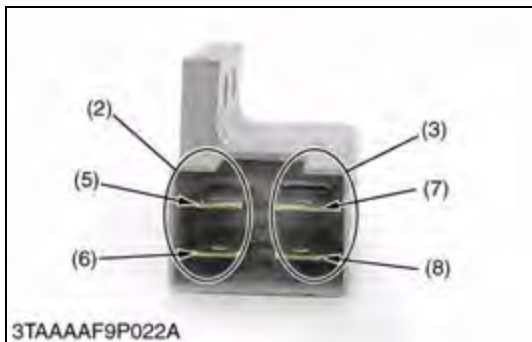

## (6) Operator Presence Control (OPC) Switch



### Seat Switch and Seat Turnover Switch Continuity Check

1. Disconnect the **2P** connectors (2) from the seat turnover switch (1) and the seat switch.
2. Remove the seat turnover switch (1).
3. Connect the circuit tester to the terminals (5).

#### (When switch is not pushed / When operator leave the seat)

1. Measure the resistance between terminals (5).
2. If continuity is not infinity, the switch is faulty. Replace it.

#### (When switch is pushed / When operator sits on the seat)

1. Measure the resistance between terminals (5).
2. If continuity is not 0 Ω, the switch is faulty. Replace it.



Resistance	When switch is not pushed / When operator leave the seat	Infinity
	When switch is pushed / When operator sits on the seat	0 Ω

- (1) Seat Turnover Switch
- (2) **2P** Connector
- (3) Seat Switch **2P** Connector
- (4) Seat
- (5) Terminal

**[A] Seat switch is not pushed.**

**[B] Seat switch is pushed.**



9Y1210855ELS0016US0



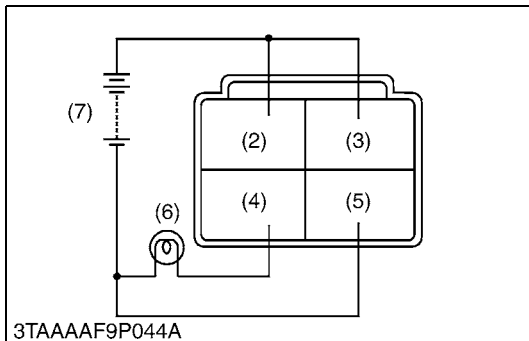
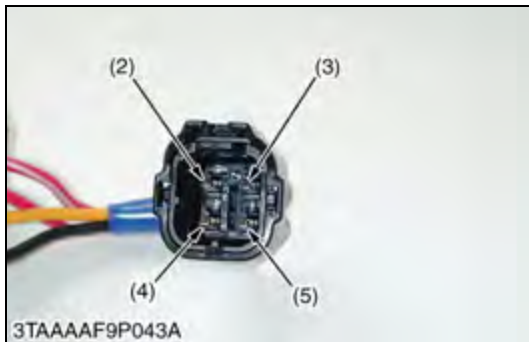
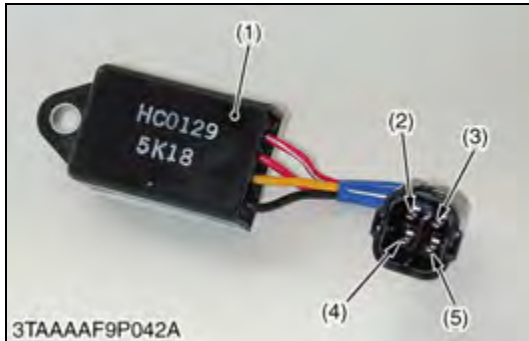

**Checking OPC Timer**

1. Remove the OPC timer. (The OPC timer is located under the fender center stay.)
2. Connect the jumper leads across the battery terminal and the Red / White terminal (2), and across the battery positive terminal and the Yellow terminal (3).
3. Connect the jumper lead across the battery negative terminal and the Black terminal (5), and across the battery negative terminal and the Blue terminal.
4. Connect the jumper lead across the Red terminal (4) and the bulb terminal.
5. The bulb lights up when disconnecting the jumper lead from the Red / White terminal (2) 0.7 to 1.3 seconds, the OPC timer (1) is proper.

- (1) OPC Timer
- (2) Red / White Terminal (From Battery)
- (3) Yellow Terminal (From OPC Switch)
- (4) Red Terminal (To Key Stop Solenoid)
- (5) Black Terminal (To Frame Earth)
- (6) Bulb (Load)
- (7) Battery

9Y1210855ELS0017US0

**(7) Fuel Pump**

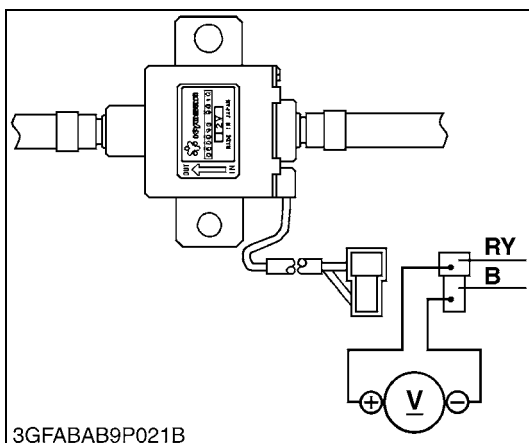

**Connector Voltage**

1. Disconnect the 2P connector from the fuel pump.
2. Turn the main switch key to the "ON" position, and measure the voltage with a voltmeter between the connector terminals.
3. If the voltage differs from the battery voltage, the wiring harness or main switch is faulty.

Voltage	Between connector terminals	Approx. battery voltage
---------	-----------------------------	-------------------------

9Y1210855ELS0018US0

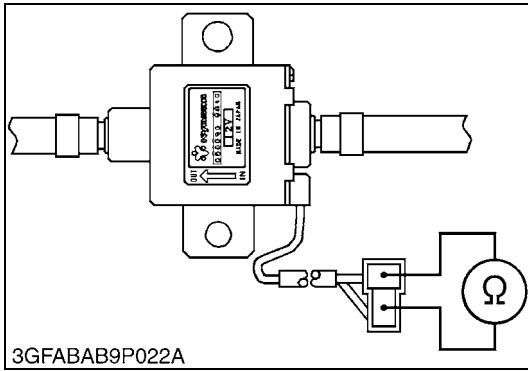

**Fuel Pump Continuity**

1. Disconnect the **2P** connector from the fuel pump.
2. Check the continuity between the connector terminals with an ohmmeter.
3. If it does not conduct, the fuel pump is faulty.

9Y1210855ELS0019US0

**(8) Engine Stop Solenoid**

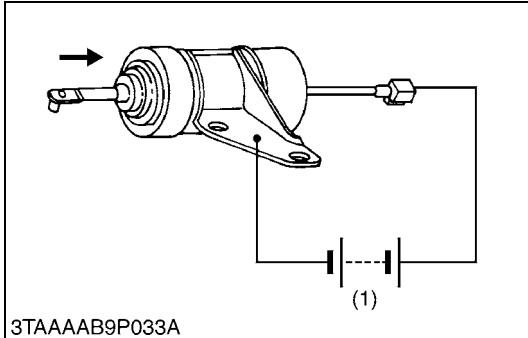

**Engine Stop Solenoid Test**

1. Disconnect the **1P** connector from the engine stop solenoid.
2. Remove the engine stop solenoid from the engine.
3. Connect the jumper leads from the battery positive terminal to the **1P** connector, and from the battery negative terminal to the engine stop solenoid body.
4. If the solenoid plunger is not attracted, the engine stop solenoid is faulty.

(1) Battery (12 V)

9Y1210855ELS0020US0

**(9) Timer Relay**

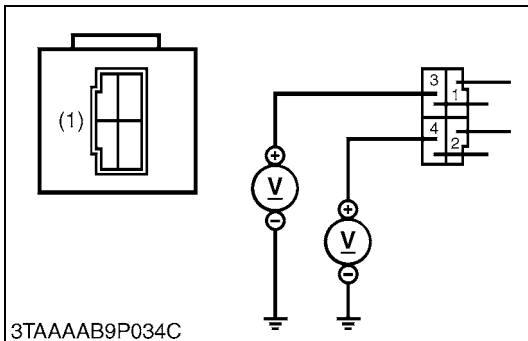

**Timer Relay Connector Voltage**

1. Disconnect the connector from the timer relay after turning the main switch off.
2. Measure the voltage with a voltmeter across the connector terminal **4** and chassis.
3. Turn the main switch on, and measure the voltage across the connector terminal **3** and chassis.
4. If these voltages differ from the battery voltage, the wiring harness or main switch is faulty.

Voltage	Connector terminal <b>4</b> – Chassis	Approx. battery voltage
	Connector terminal <b>3</b> – Chassis	Approx. battery voltage

(1) Timer Relay

9Y1210855ELS0021US0

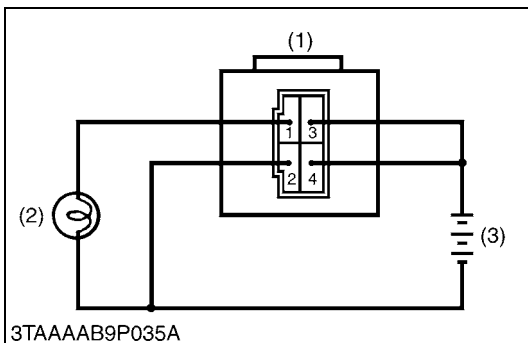

**Test of Timer Relay**

1. Remove the timer relay from the tractor.
2. Connect jumper leads across the battery positive terminal and the timer relay terminal **3**, and across the battery positive terminal and the timer relay terminal **4**.
3. Connect jumper leads across the battery negative terminal and the timer relay terminal **2**, and across the battery negative terminal and the bulb terminal.
4. Connect jumper lead across the timer relay terminal **1** and the bulb terminal.
5. The bulb lights up when disconnecting a jumper lead from the terminal **3** and goes off 6 to 13 seconds later, the timer relay is proper.

(1) Timer Relay  
(2) Load (Lamp)

(3) Battery (12 V)

9Y1210855ELS0022US0

### (10) Charging System

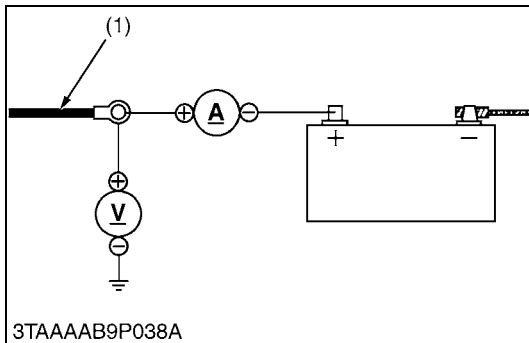

#### Battery Charging Current

1. After starting the engine, disconnect the battery positive cord (+), and connect an ammeter and voltmeter. Then switch on all electrical loads (such as head lights) and measure the charging current.

■ **NOTE**

- Connect an ammeter only after starting the engine.
- When the electrical loads is considerably low or the battery is fully charged, the specified reading may not be obtained.

Current	Factory specification	14 to 15 A
Voltage		14 to 15 V
Alternator speed		5200 min <sup>-1</sup> (rpm)

(1) Battery Positive Cord

9Y1210855ELS0023US0

### (11) Combination Switch



#### Combination Switch

1. Remove the meter panel, and disconnect the combination switch connector.
2. Remove the combination switch (1) and perform the following checks **1) to 8)**.

- |                        |                        |
|------------------------|------------------------|
| (1) Combination Switch | (6) Yellow Lead        |
| (2) Red / Yellow Lead  | (7) Orange Lead        |
| (3) Green Lead         | (8) Red / White Lead   |
| (4) Black / Blue Lead  | (9) Green / White Lead |
| (5) Blue / White Lead  |                        |

9Y1210855ELS0029US0

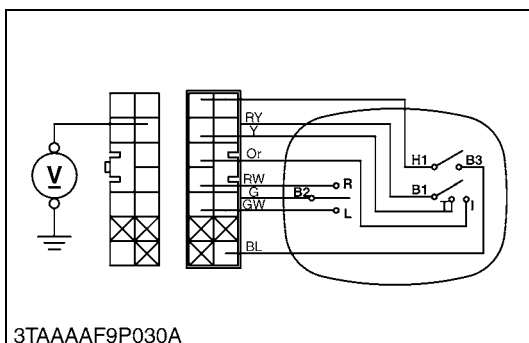

#### 1) Connector Voltage

1. Connect the combination switch connector to the main wire harness.
2. Measure the voltage with a voltmeter across the connector **B1** terminal and chassis when the main switch is **ON** position.
3. If the voltage differs from the battery voltage, the wiring harness and main switch is faulty.

Voltage	Main switch at <b>ON</b> position	<b>B1</b> terminal – Chassis	Battery voltage
---------	-----------------------------------	------------------------------	-----------------

9Y1210855ELS0030US0





**2) Head Light Switch Continuity when Setting Switch at "OFF" Position**

1. Set the light switch to the **OFF** position.
2. Measure the resistance with an ohmmeter across the red / yellow lead (1) to the orange lead (4), the red / yellow lead (1) to the yellow lead (3).
3. If infinity is not indicated, the head light switch is faulty.

Resistance (Switch at <b>OFF</b> position)	Red / Yellow lead (1) – Orange lead (4)	Infinity
	Red / Yellow lead (1) – Yellow lead (3)	



- (1) Red / Yellow Lead
- (2) Blue / White Lead
- (3) Yellow Lead
- (4) Orange Lead
- (5) Red / White Lead

**A: Head Light "OFF" Position**

9Y1210855ELS0031US0



**3) Head Light Switch Continuity when Setting Switch at "ON" Position**

1. Set the light switch to the **ON** position.
2. Measure the resistance with an ohmmeter across the red / yellow lead (1) to the orange lead (4) and the red / yellow lead (1) to the yellow lead (3).
3. If infinity is not indicated, the head light switch is faulty.

Resistance (Switch at <b>ON</b> position)	Red / Yellow lead (1) – Orange lead (4)	0 Ω
	Red / Yellow lead (1) – Yellow lead (3)	



- (1) Red / Yellow Lead
- (2) Blue / White Lead
- (3) Yellow Lead
- (4) Orange Lead
- (5) Red / White Lead

**A: Head Light "OFF" Position**  
**B: Head Light "ON" Position**

9Y1210855ELS0032US0



**4) Turn Signal Light Switch Continuity when Setting Switch Knob "OFF" Position**

1. Set the turn signal switch knob to the **OFF** position.
2. Measure the resistance with an ohmmeter across the green lead (1) and red / white lead (2), and across to the green lead (1) and green / white lead (3).
3. If infinity is not indicated, the combination switch is faulty.

Resistance (Switch knob at <b>OFF</b> position)	Green lead (1) – Red / White lead (2)	0 Ω
	Green lead (1) – Green / White lead (3)	

- (1) Green Lead
- (2) Red / White Lead
- (3) Green / White Lead

**A: Turn Signal Light Switch "OFF" Position**

9Y1210855ELS0033US0

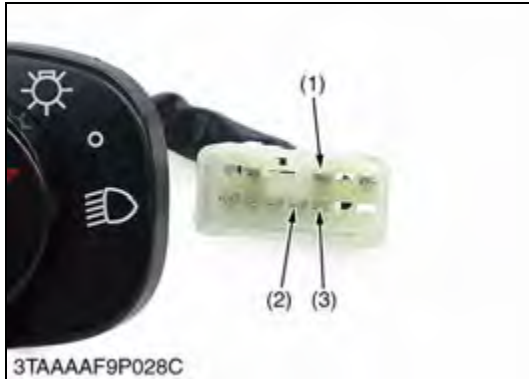

**5) Turn Signal Light Switch Continuity when Setting Switch Knob "RIGHT" Position**

1. Set the turn signal switch knob to the **RIGHT** position.
2. Measure the resistance with an ohmmeter across the green lead (1) and red / white lead (2), and across to the green lead (1) and green / white lead (3).
3. If 0 Ω is not indicated, the combination switch is faulty.

Resistance (Switch knob at <b>OFF</b> position)	Green lead (1) – Red / White lead (2)	0 Ω
	Green lead (1) – Green / White lead (3)	Infinity

- (1) Green Lead
- (2) Red / White Lead
- (3) Green / White Lead

**A: Turn Signal Light Switch "RIGHT" Position**

9Y1210855ELS0034US0





**6) Turn Signal Light Switch Continuity when Setting Switch Knob "LEFT" Position**

1. Set the turn signal switch knob to the **LEFT** position.
2. Measure the resistance with an ohmmeter across the green lead (1) and red / white lead (2), and across to the green lead (1) and green / white lead (3).
3. If 0 Ω is not indicated, the combination switch is faulty.

Resistance (Switch knob at <b>LEFT</b> position)	Green lead (1) – Red / White lead (2)	Infinity
	Green lead (1) – Green / White lead (3)	0 Ω

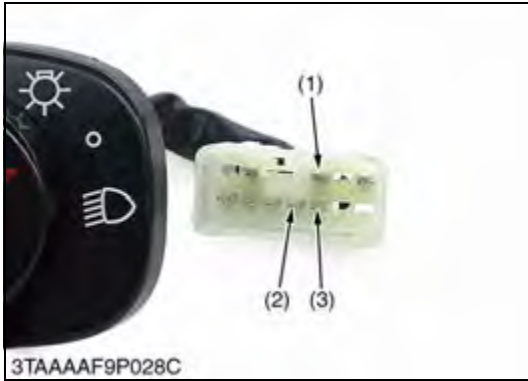

- (1) Green Lead
- (2) Red / White Lead
- (3) Green / White Lead

**A: Turn Signal Light Switch "LEFT" Position**

9Y1210855ELS0035US0



**7) Hazard Switch Continuity when Setting Switch Knob at "OFF" Position**

1. Set the hazard switch knob to the **OFF** position.
2. Measure the resistance with an ohmmeter across the black / blue lead (1) and blue / white lead (2).
3. If infinity is not indicated, the combination switch is faulty.

Resistance (Hazard switch at <b>OFF</b> position)	Black / Blue lead (1) – Blue / White lead (2)	Infinity
--	---	----------

- (1) Black / Blue Lead
- (2) Blue / White Lead

**A: Hazard Switch "OFF" Position**

9Y1210855ELS0036US0







**8) Hazard Switch Knob at "ON" Position**

1. Set the hazard switch knob to the **ON** position.
2. Measure the resistance with an ohmmeter across the black / blue lead (1) and blue / white lead (2).
3. If 0 Ω is not indicated, the combination switch is faulty.

Resistance (Hazard switch at <b>ON</b> position)	Black / Blue lead (1) – Blue / White lead (2)	0 Ω
--	--	-----

- (1) Black / Blue Lead
- (2) Blue / White Lead

**A: Hazard Switch "ON" Position**

9Y1210855ELS0037US0

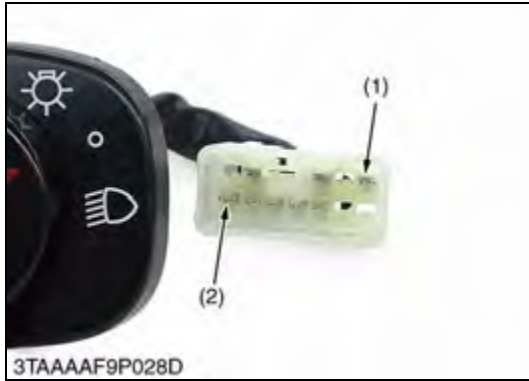

**Flasher Unit**

1. Remove the under panel.
2. Disconnect the coupler (2) from flasher unit.
3. Measure the voltage with a voltmeter across the terminal **h** and terminal **c** or chassis.
4. If the voltage differs from the battery voltage, the wiring harness is faulty.

Voltage	Terminal <b>h</b> – Terminal <b>c</b> or Chassis	Approx. battery voltage
---------	---	-------------------------

- (1) Flasher Unit

- (2) Coupler

9Y1210855ELS0038US0

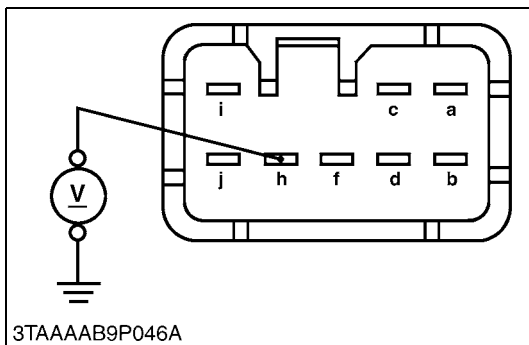

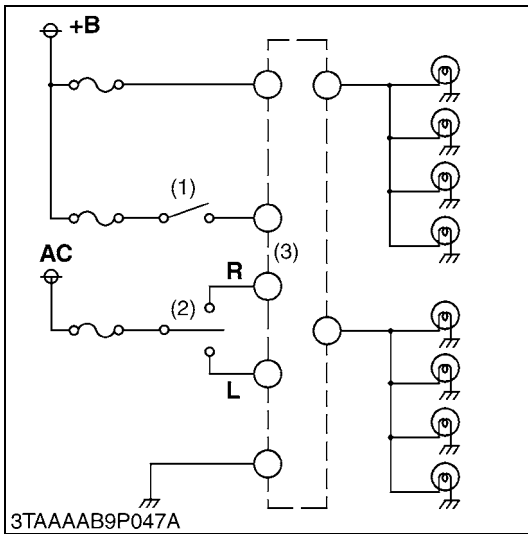

**Flasher Unit Actuation Test**

1. Set the hazard switch to the **ON** position, and make sure the hazard lamp gives 60 to 85 flashes for a minute.
2. With the main switch and the hazard switch at the **ACC** and **ON** positions, respectively, move the turn signal light switch to the left. Make sure that the right-hand light stays on and the left-hand light gives flashes earlier (by about 20 flashes) than when the hazard lamp is activated. Then move the turn signal light switch to the right and make sure the corresponding actions take place.
3. Now set the main switch to the **ACC** position and move the turn signal switch alone. Make sure the same actions as above result.
4. If both the hazard switch and the turn signal light switch function but the above actions do not take place, replace the flasher unit with new one.

- (1) Hazard Lamp Switch (3) Flasher Unit  
 (2) Turn Signal Light Switch

9Y1210855ELS0039US0

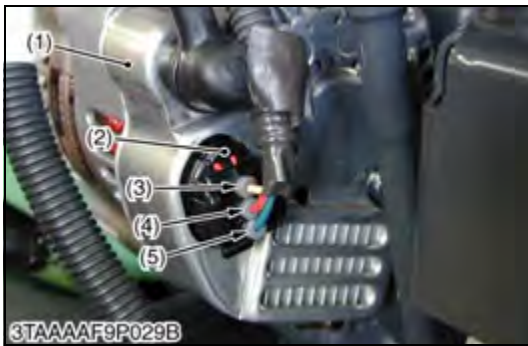

**Charge Lamp (Charging Circuit)**

1. Disconnect the **3P** connector from the alternator after turning the main switch **OFF**.
2. Turn the main switch **ON** and connect a jumper lead from the wiring harness connector terminal (White / Red) to the chassis.

**NOTE**

- If you connect the jumper lead from the wiring harness connector terminal (White / Red) to the chassis, 15 A fuse will be blown. Do not connect the lead to Red / Yellow terminal.

3. If the charge lamp does not light, the wiring harness or fuse is faulty.

- (1) Alternator (A: To the Battery)  
 (2) 3P Connector (B: To Hour Meter and Tachometer)  
 (3) L (Blue) Terminal (C: To Main Switch)  
 (4) RY (Red / Yellow) Terminal (D: To Charge Indicator)  
 (5) WR (White / Red) Terminal

9Y1210855ELS0040US0

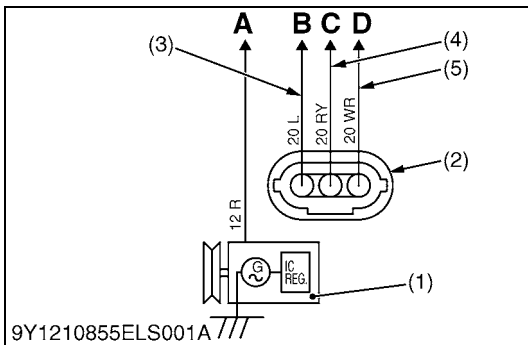



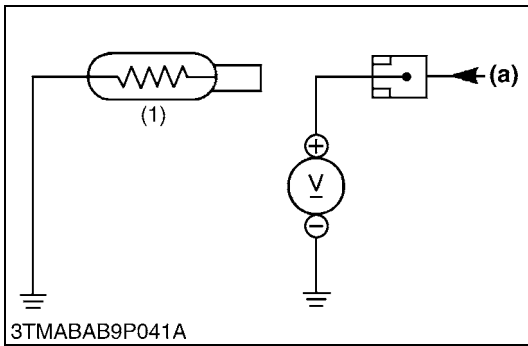

### Coolant Temperature Sensor (Thermo Unit)

#### 1) Lead Terminal Voltage

1. Disconnect the lead from the coolant temperature sensor after turning the main switch **OFF**.
2. Turn the main switch **ON** and measure the voltage with a voltmeter across the lead terminal and the chassis.  
If the voltage differs from the battery voltage, the wiring harness, fuse or coolant temperature gauge is faulty.

Voltage	Lead terminal – Chassis	Approx. battery voltage
---------	-------------------------	-------------------------

#### 2) Sensor Continuity

1. Measure the resistances with an ohmmeter across the sensor terminal and the chassis.
2. If the reference value is not indicated, the sensor is faulty.

Resistance (Sensor terminal – Chassis)	Reference value	Approx. 16.1 Ω at 120 °C (248 °F)
		Approx. 27.4 Ω at 100 °C (212 °F)
		Approx. 51.9 Ω at 80 °C (176 °F)
		Approx. 153.9 Ω at 50 °C (122 °F)

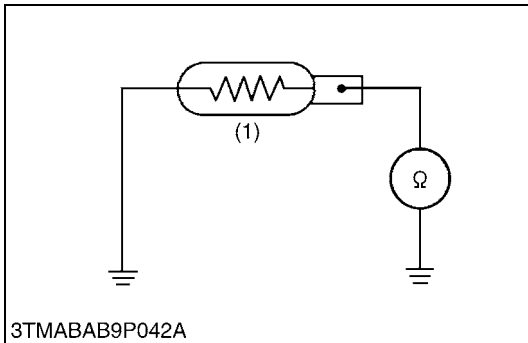

(1) Coolant Temperature Sensor (a) From Temperature Gauge

9Y1210855ELS0044US0

### Hour Meter and Tachometer

1. Disconnect the **3P** connector (4) from the IC regulator (9) located in the alternator (5) after starting the engine.
2. Measure the voltage with a voltmeter across the hour meter terminal (6) and the alternator body when the hour meter or tachometer does not indicated the proper value.
3. If the measured voltages differ from the specified voltage, the hour meter and tachometer is faulty.

Voltage while engine runs at idling speeds	Hour meter terminal – Alternator body	Approx. battery voltage
--	---------------------------------------	-------------------------

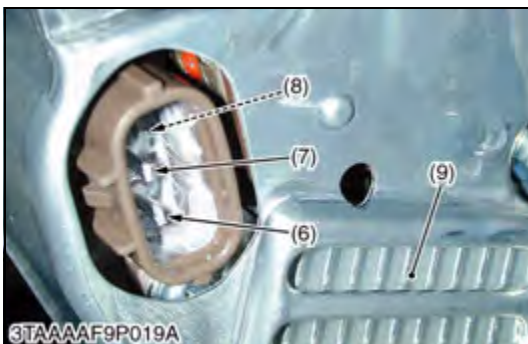
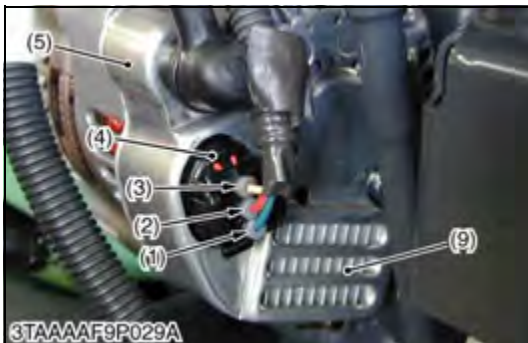

- |  |  |
|--|--|
| (1) L (Blue) Lead                      | <b>A: To the Battery</b>               |
| (2) RY (Red / Yellow) Lead             | <b>B: To Hour Meter and Tachometer</b> |
| (3) WR (White / Red) Lead              | <b>C: To Main Switch</b>               |
| (4) <b>3P</b> Connector                | <b>D: To Charge Indicator</b>          |
| (5) Alternator                         |  |
| (6) Hour Meter and Tachometer Terminal |  |
| (7) Ground Terminal                    |  |
| (8) Charge Lamp Terminal               |  |
| (9) IC Regulator                       |  |

9Y1210855ELS0045US0

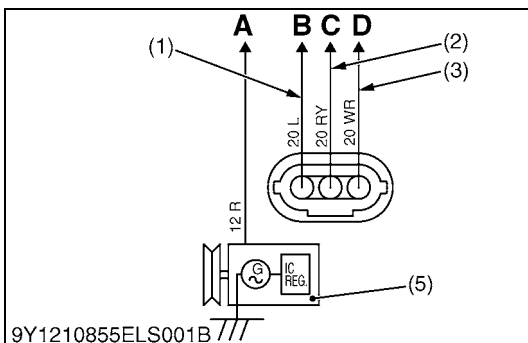



### (13) DC Outlet

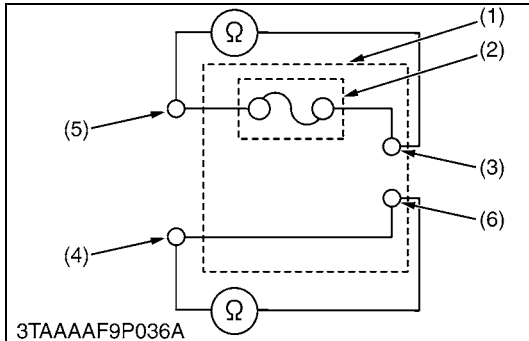
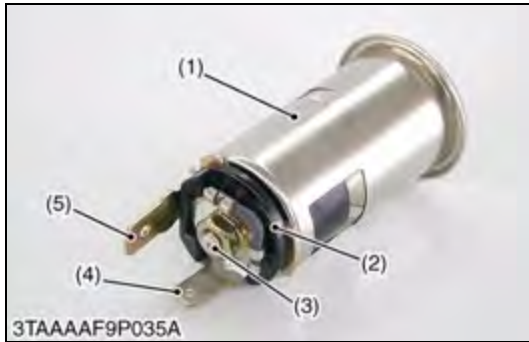

#### DC Outlet Connector Voltage and DC Outlet Continuity

1. Disconnect the connector from the DC outlet. And turn the main switch "ON".
2. Measure the voltage with a voltmeter across the connector red / blue lead and the chassis.  
If the voltage differs from the battery voltage the wiring harness is faulty.
3. Disconnect the connector from the DC outlet. Since the DC outlet can not be removed easily, measure the continuity with a ohm meter across the plus terminal (4) and the nut (3), and across the earth terminal (5) and the DC outlet case (6).
4. If the resistance differs from 0 ohm, the DC outlet body (1) is faulty.

DC outlet connector voltage	Red / Blue lead – Chassis	Battery voltage
DC outlet continuity	Plus terminal – Nut	0 Ω
	Earth terminal – DC outlet case	

- (1) DC Outlet Body
- (2) Fuse
- (3) Nut
- (4) Plus Terminal (for Battery)
- (5) Earth Terminal (for Chassis)
- (6) DC Outlet Case

9Y1210855ELS0046US0

### (14) Meter Panel

#### [A] Removing The Meter Panel



#### Battery



#### CAUTION

- When disconnecting the battery cables, disconnect the negative cable from the battery first. When connecting, connect the positive cable to the battery first.

1. Remove the under panel (1).
2. Disconnect the negative cable (3) from the battery (2).

- (1) Under Panel
- (2) Battery
- (3) Negative Cable

9Y1210855ELS0047US0



**Hand Throttle Lever and Grip**

1. Remove the throttle wire cable (1).
2. Remove the hand throttle lever nuts (2).
3. Remove the cruise lever grip (8) and hand throttle lever grip (7).
4. Remove the upper panel (6) mounting screw.

**(When reassembling)**

- Be sure to assemble the belleville washers (4) and plane washer (5) to the original position.
- Adjust the hand throttle lever operating force as below.

Hand throttle lever operating force	Factory specification	89.0 to 111 N 9.08 to 11.3 kgf 20 to 25 lbf
-------------------------------------	-----------------------	---

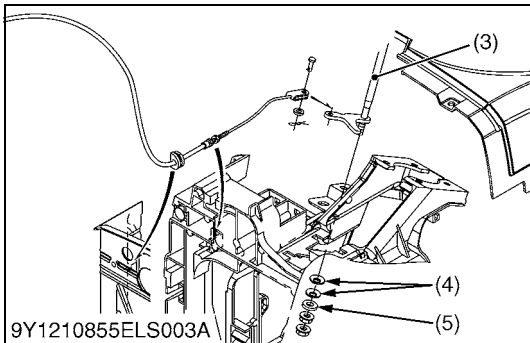

- |                         |                              |
|-------------------------|------------------------------|
| (1) Throttle Wire Cable | (5) Plane Washer             |
| (2) Nut                 | (6) Upper Panel              |
| (3) Hand Throttle Lever | (7) Hand Throttle Lever Grip |
| (4) Belleville Washer   | (8) Cruise Lever Grip        |

9Y1210855ELS004US0



**Meter Panel with Upper Panel**

1. Disconnect the connectors (2), (3) and (4).
2. Remove the meter panel with upper panel (1).

- |                             |                                    |
|-----------------------------|------------------------------------|
| (1) Upper Panel             | (3) Connector (Meter Panel)        |
| (2) Connector (Main Switch) | (4) Connector (Combination Switch) |

9Y1210855ELS0049US0



## [B] Checking Meter Panel

### ⚠ CAUTION

- For checking of electric circuit, use the circuit tester.
- As for the checking of sensors and switches, do the following order; check the battery, fuse and grounding line first, check by the test function of meter panel next, and check the connectors of panel or related electronic switch or sensor. If any problem is found there, check individual sensors or switches to see whether the problem exists at the sensor and switch side or at the wire harness side.
- When any problem is not found for sensors, switches and harness, replace meter panel with new one.

### ■ IMPORTANT

- When connecting or disconnecting the connector for the purpose of checking, be sure to turn OFF the main switch before hand. Moreover, pay attention not to allow the terminal to come in contact with other terminal or chassis while checking.
- When applying the test pin of the tester to the connector terminals, use care not to damage to the connector terminal.

9Y1210855ELS0050US0

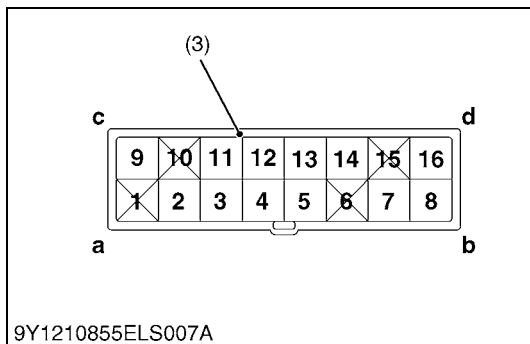

### Checking Connector Voltage, Sensor Resistance and Switch

1. Disconnect the **16P** connector (3) from the meter panel.
2. Check the main voltage (battery voltage) first and check the connector voltage, sensor resistance or switch continuity which related for damaged indication of meter panel as table below.

#### [16P Connector: Wire Harness Side]

Terminal No.	Color of wiring	Terminal name (Related item)
T1	–	–
T2	R/G	Battery
T3	Br	Back Light
T4	L	Tachometer (Alternator)
T5	G	Engine Oil Pressure Switch
T6	–	–
T7	B/R	Glow Plug
T8	W/R	Battery Charge
T9	R/Y	Switched Power (Alternator)
T10	–	–
T11	R/W	Right Turn (Combination Switch)
T12	L/W	Left Turn (Combination Switch)
T13	W/Y	Water Temperature Sensor
T14	Y/L	Fuel Level Sensor
T15	–	–
T16	B	Ground

- |                                     |                             |
|-------------------------------------|-----------------------------|
| (1) Meter Panel                     | <b>a: Terminal 1 (T1)</b>   |
| (2) 16P Connector Meter Panel Side  | <b>b: Terminal 8 (T8)</b>   |
| (3) 16P Connector Wire Harness Side | <b>c: Terminal 9 (T9)</b>   |
|                                     | <b>d: Terminal 16 (T16)</b> |

9Y1210855ELS0051US0

## [2] DISASSEMBLING AND ASSEMBLING

### (1) Starter

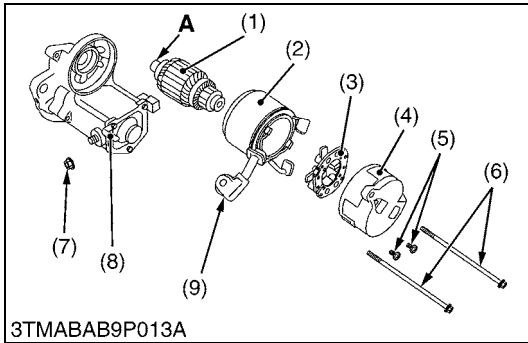

#### Motor

1. Disconnect the connecting lead (9) from the magnet switch (8).
2. Remove the screws (6), and then separate the end frame (4), yoke (2) and armature (1).
3. Remove the two screws (5), and then remove the brush holder (3) from the end frame (4).

#### (When reassembling)

- Apply grease to the spline teeth "A" of the armature (1).

Tightening torque	Nut (7)	5.9 to 11.8 N·m 0.6 to 1.2 kgf·m 4.3 to 8.7 lbf·ft
-------------------	---------	--

- |                  |                        |
|------------------|------------------------|
| (1) Armature     | (7) Nut                |
| (2) Yoke         | (8) Magnet Switch      |
| (3) Brush Holder | (9) Connecting Lead    |
| (4) End Frame    |                        |
| (5) Screw        | <b>A: Spline Teeth</b> |
| (6) Screw        |                        |

9Y1210855ELS0052US0

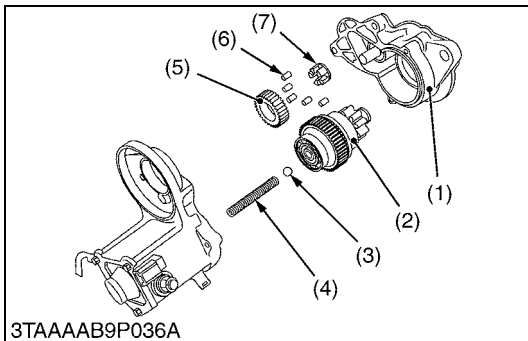

#### Magnet Switch

1. Remove the drive end frame (1) mounting screws.
2. Remove the overrunning clutch (2), ball (3), spring (4), gears (5), rollers (6) and retainer (7).

#### (When reassembling)

- Apply grease to the gear teeth of the gears (5) and overrunning clutch (2), and ball (3).

- |                        |              |
|------------------------|--------------|
| (1) Drive End Frame    | (5) Gear     |
| (2) Overrunning Clutch | (6) Roller   |
| (3) Ball               | (7) Retainer |
| (4) Spring             |              |

9Y1210855ELS0053US0

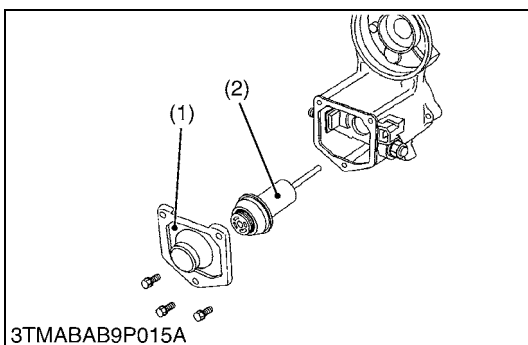

#### Plunger

1. Remove the end cover (1).
2. Remove the plunger (2).

- |               |             |
|---------------|-------------|
| (1) End Cover | (2) Plunger |
|---------------|-------------|

9Y1210855ELS0054US0



## (2) Alternator

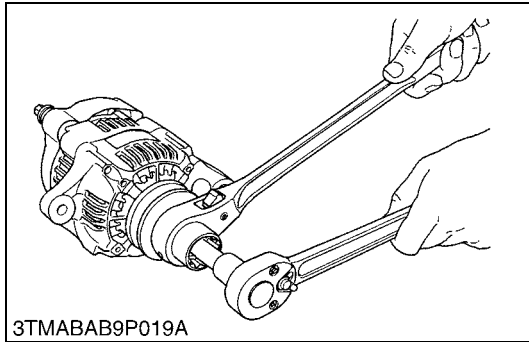

3TMABAB9P019A

### Pulley

1. Secure the hexagonal end of the pulley shaft with a double-ended ratchet wrench as shown in the figure, loosen the pulley nut with a socket wrench and remove it.

**(When reassembling)**

Tightening torque	Pulley nut	58.4 to 78.9 N·m 5.95 to 8.05 kgf·m 43.1 to 58.2 lbf·ft
-------------------	------------	---

9Y1210436ELS0004US0

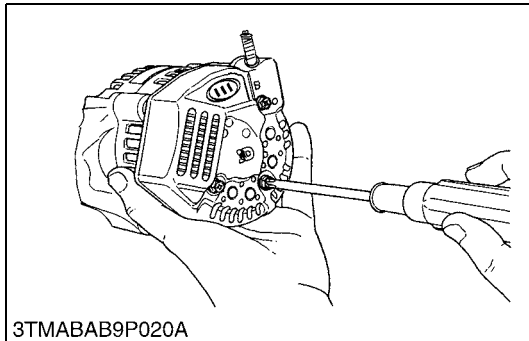

3TMABAB9P020A

### Rear End Cover

1. Remove the three rear end cover screws and the **B** terminal nut, and remove the rear end cover.

9Y1210855ELS0055US0

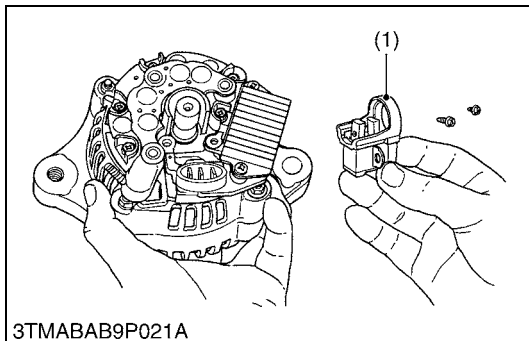

3TMABAB9P021A

### Brush Holder

1. Remove the two screws holding the brush holder, and remove the brush holder (1).

(1) Brush Holder

9Y1210855ELS0059US0

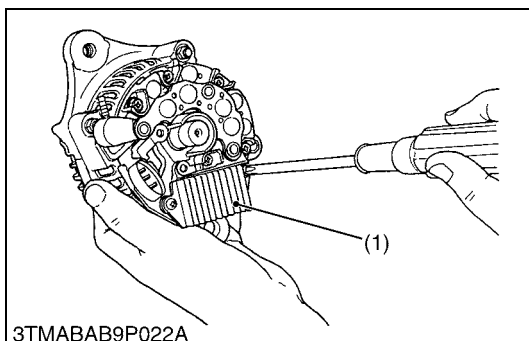

3TMABAB9P022A

### IC Regulator

1. Remove the three screws holding the IC regulator, and remove the IC regulator (1).

(1) IC Regulator

9Y1210855ELS0060US0

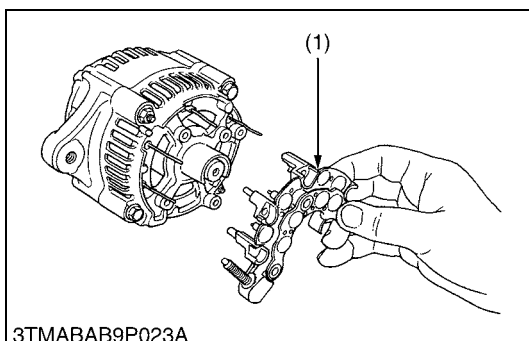

3TMABAB9P023A

### Rectifier

1. Remove the four screws holding the rectifier and the stator lead wires.
2. Remove the rectifier (1).

(1) Rectifier

9Y1210436ELS0008US0

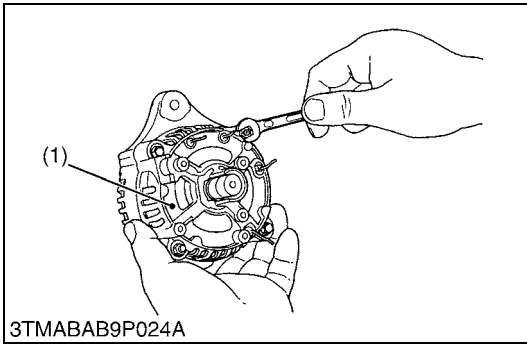

**Rear End Frame**

1. Remove the two nuts and two screws holding the drive end frame and the rear end frame.
2. Remove the rear end frame (1).

(1) Rear End Frame

9Y1210855ELS0061US0

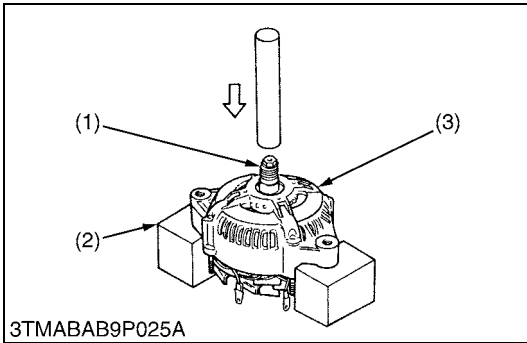

**Rotor**

1. Press out the rotor (1) from drive end frame (3).

**■ IMPORTANT**

- Take special care not to drop the rotor and damage the slip ring or fan, etc..

(1) Rotor

(3) Drive End Frame

(2) Block

9Y1210436ELS0010US0

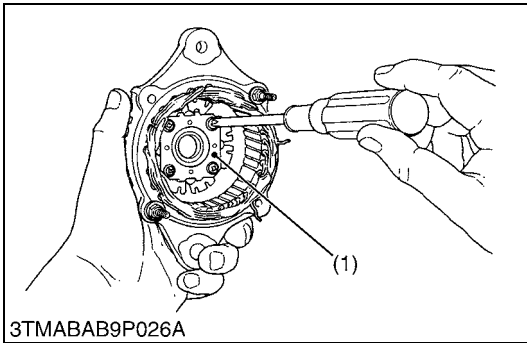

**Retainer Plate**

1. Remove the four screws holding the retainer plate, and remove the retainer plate (1).

(1) Retainer Plate

9Y1210855ELS0062US0

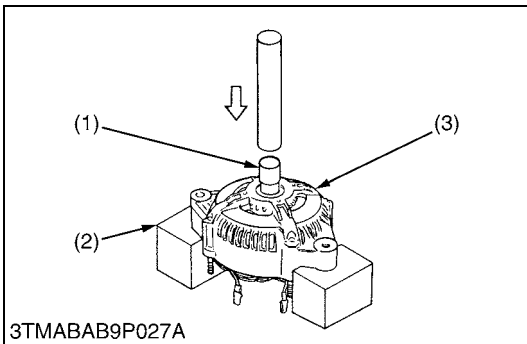

**Bearing on Drive End Side**

1. Press out the bearing from drive end frame (3) with a press and jig (1).

(1) Jig

(3) Drive End Frame

(2) Block

9Y1210436ELS0012US0

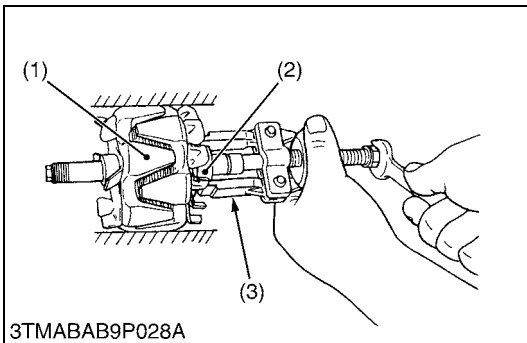

**Bearing at Slip Ring Side**

1. Lightly secure the rotor (1) with a vise to prevent damage, and remove the bearing (2) with a puller (3).

(1) Rotor

(3) Puller

(2) Bearing

9Y1210436ELS0013US0

### [3] SERVICING

#### (1) Starter

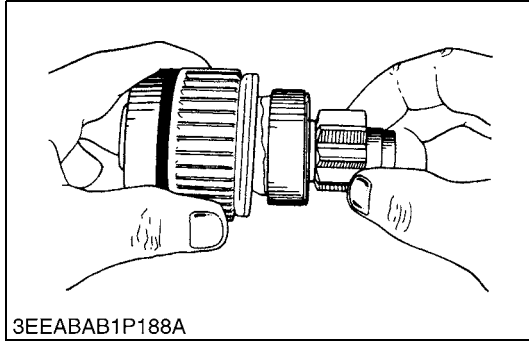

3EEABAB1P188A

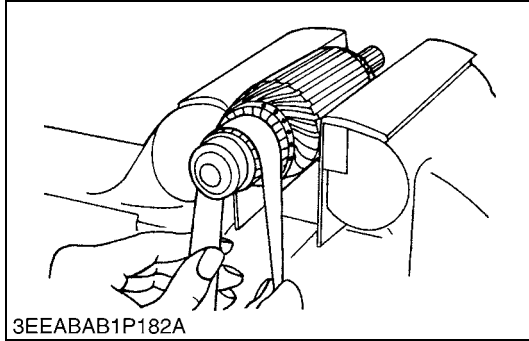

3EEABAB1P182A

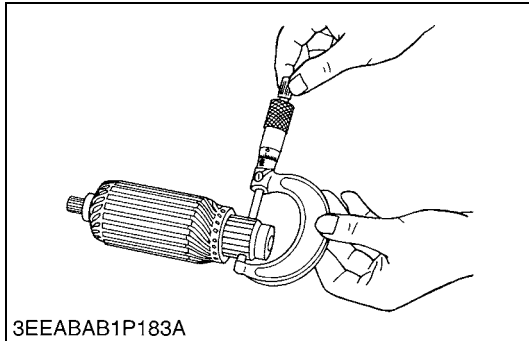

3EEABAB1P183A

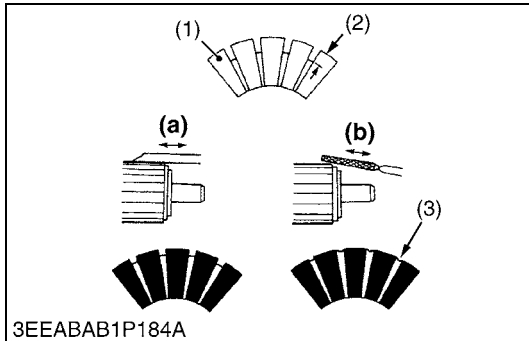

3EEABAB1P184A

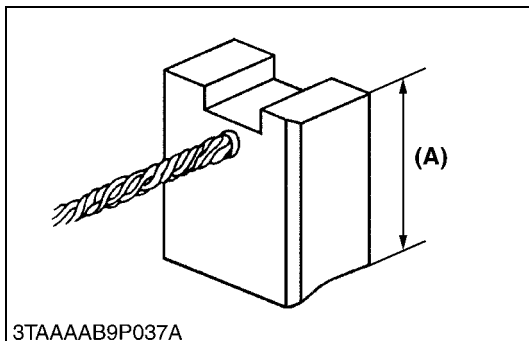

3TAAAB9P037A

#### Overrunning Clutch

1. Inspect the pinion for wear or damage.
2. If there is any problem, replace the overrunning clutch assembly.
3. Check that the pinion turns freely and smoothly in the overrunning direction and does not slip in the cranking direction.
4. If the pinion slips or does not rotate in the both directions, replace the overrunning clutch assembly.

WSM000001ELS0033US0

#### Commutator and Mica

1. Check the contact face of the commutator for wear, and grind the commutator with emery paper if it is slightly worn.
2. Measure the commutator O.D. with an outside micrometer at several points.
3. If the minimum O.D. is less than the allowable limit, replace the armature.
4. If the difference of the O.D.'s exceeds the allowable limit, correct the commutator on a lathe to the factory specification.
5. Measure the mica undercut.
6. If the undercut is less than the allowable limit, correct it with a saw blade and chamfer the segment edges.

Commutator O.D.	Factory specification	30.0 mm 1.181 in.
	Allowable limit	29.0 mm 1.142 in.

Difference of O.D.'s	Factory specification	Less than 0.02 mm 0.0008 in.
	Allowable limit	0.05 mm 0.0020 in.

Mica undercut	Factory specification	0.50 to 0.80 mm 0.0197 to 0.0315 in.
	Allowable limit	0.20 mm 0.0079 in.

- |              |                      |
|--------------|----------------------|
| (1) Segment  | (a) <b>Correct</b>   |
| (2) Undercut | (b) <b>Incorrect</b> |
| (3) Mica     |                      |

9Y1210855ELS0056US0

#### Brush Wear

1. If the contact face of the brush is dirty or dusty, clean it with emery paper.
2. Measure the brush length (A) with vernier calipers.
3. If the length is less than the allowable limit, replace the yoke assembly and brush holder.

Brush length (A)	Factory specification	14.0 mm 0.551 in.
	Allowable limit	9.0 mm 0.354 in.

9Y1210855ELS0057US0

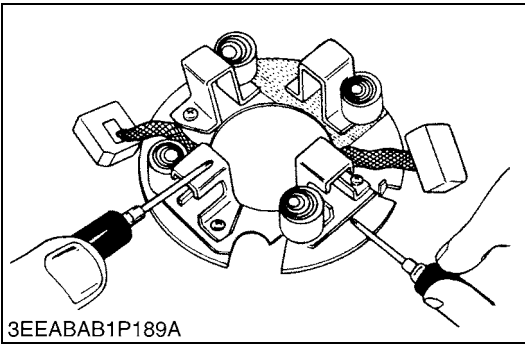

**Brush Holder**

1. Check the continuity across the brush holder and the holder support with an ohmmeter.
2. If it conducts, replace the brush holder.

9Y1210855ELS0058US0

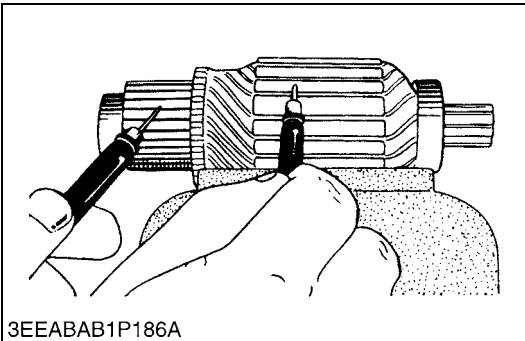

**Armature Coil**

1. Check the continuity across the commutator and armature coil core with an ohmmeter.
2. If it conducts, replace the armature.
3. Check the continuity across the segments of the commutator with an ohmmeter.
4. If it does not conduct, replace the armature.

WSM000001ELS0037US0

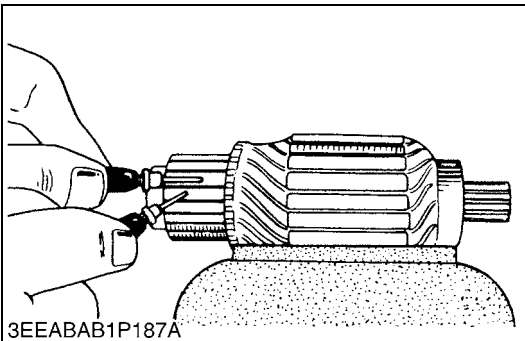

**Field Coil**

1. Check the continuity across the lead (1) and brush (2) with an ohmmeter.
2. If it does not conduct, replace the yoke assembly.
3. Check the continuity across the brush (2) and yoke (3) with an ohmmeter.
4. If it conducts, replace the yoke assembly.

- |           |          |
|-----------|----------|
| (1) Lead  | (3) Yoke |
| (2) Brush |          |

WSM000001ELS0038US0

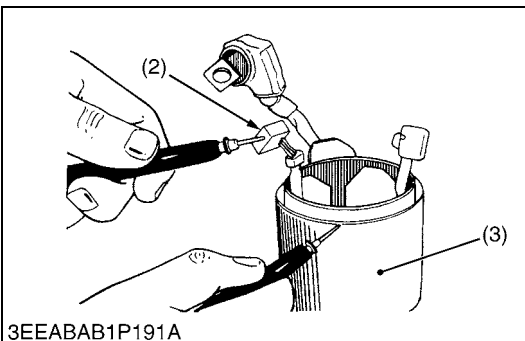
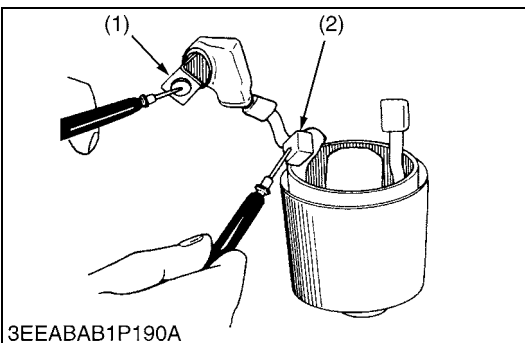

## (2) Alternator

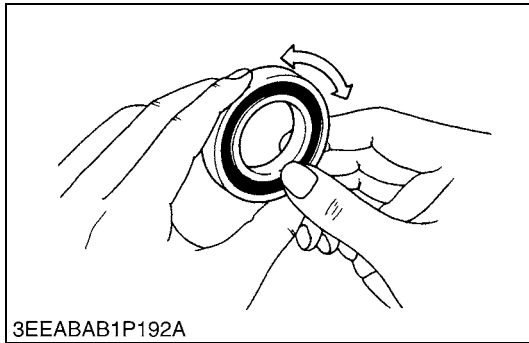

3EEABAB1P192A

### Bearing

1. Check the bearing for smooth rotation.
2. If it does not rotate smoothly, replace it.

WSM000001ELS0039US0

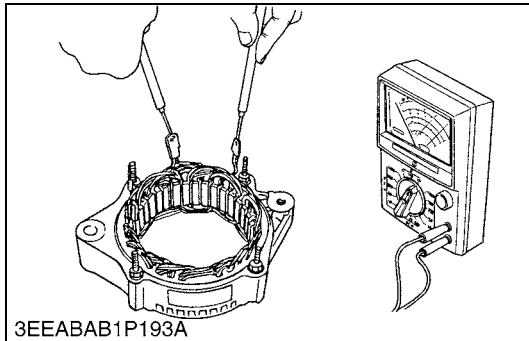

3EEABAB1P193A

### Stator

1. Measure the resistance across each lead of the stator coil with resistance range of circuit tester.
2. If the measurement is not within factory specification, replace it.
3. Check the continuity across each stator coil lead and core with resistance range of circuit tester.
4. If infinity is not indicated, replace it.

Resistance	Factory specification	Less than 1.0 Ω
------------	-----------------------	-----------------

9Y1210855ELS0024US0

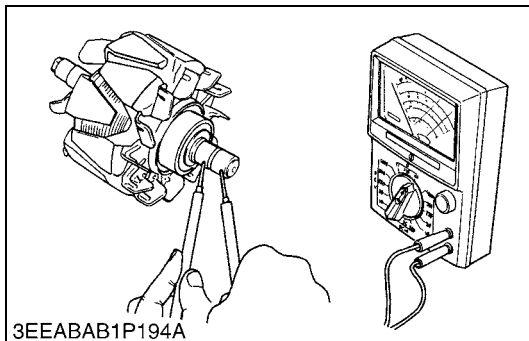

3EEABAB1P194A

### Rotor

1. Measure the resistance across the slip rings.
2. If the resistance is not the factory specification, replace it.
3. Check the continuity across the slip ring and core with resistance range of circuit tester.
4. If infinity is not indicated, replace it.

Resistance	Factory specification	2.9 Ω
------------	-----------------------	-------

9Y1210855ELS0025US0

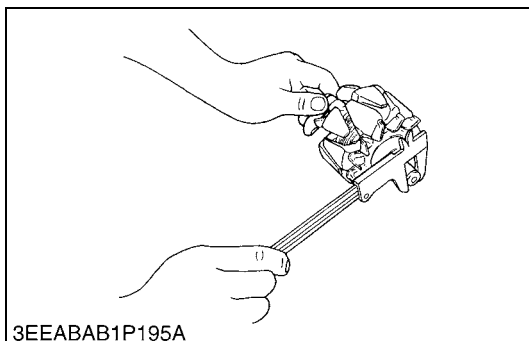

3EEABAB1P195A

### Slip Ring

1. Check the slip ring for score.
2. If scored, correct with an emery paper or on a lathe.
3. Measure the O.D. of slip ring with vernier calipers.
4. If the measurement is less than the allowable limit, replace it.

Slip ring O.D.	Factory specification	14.4 mm 0.567 in.
	Allowable limit	14.0 mm 0.551 in.

9Y1210855ELS0026US0

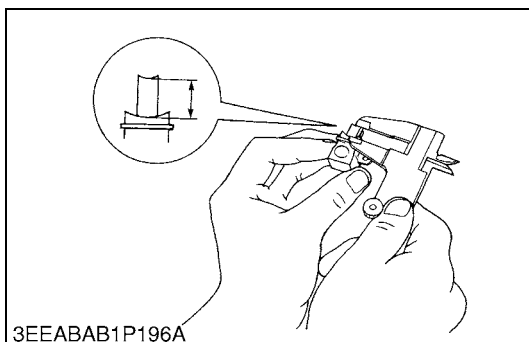

3EEABAB1P196A

### Brush Wear

1. Measure the brush length with vernier calipers.
2. If the measurement is less than allowable limit, replace it.
3. Make sure that the brush moves smoothly.
4. If the brush is damaged, replace it.

Brush length	Factory specification	10.5 mm 0.413 in.
	Allowable limit	8.4 mm 0.331 in.

9Y1210855ELS0027US0

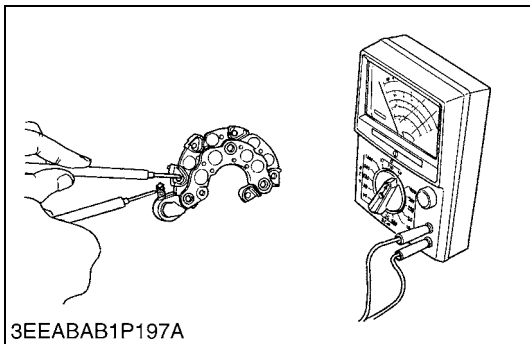

**Rectifier**

1. Check the continuity across each diode of rectifier with resistance range of circuit tester.
2. The rectifier is normal if the diode in the rectifier conducts in one direction and does not conduct in the reverse direction.

9Y1210855ELS0028US0

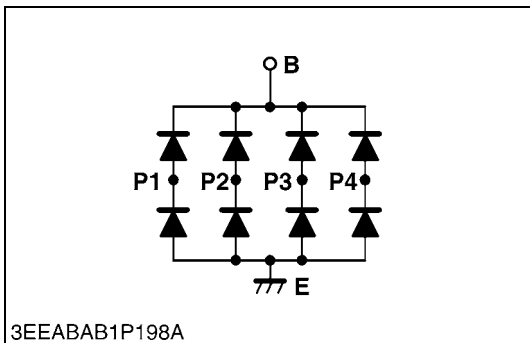

# **7 MOWER**

# MECHANISM

## CONTENTS

1. POWER TRANSMISSION .....	7-M1
2. LIFTING MECHANISM .....	7-M2
3. SELF-BALANCER SYSTEM .....	7-M3



# 1. POWER TRANSMISSION

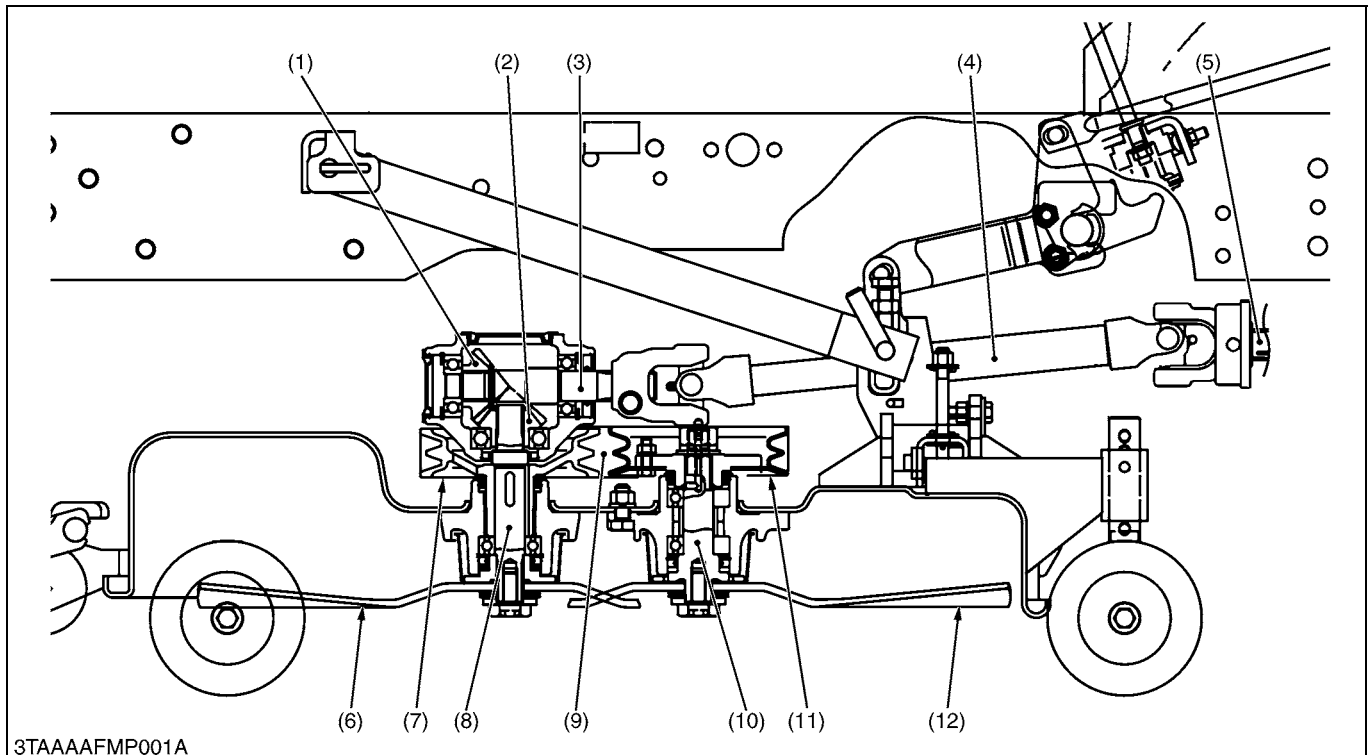

3TAAAFMP001A

- |                  |                     |                      |                   |
|------------------|---------------------|----------------------|-------------------|
| (1) Bevel Gear   | (4) Universal Joint | (7) Center Pulley    | (10) Blade Shaft  |
| (2) Bevel Gear   | (5) Mid-PTO Shaft   | (8) Bevel Gear Shaft | (11) Outer Pulley |
| (3) Pinion Shaft | (6) Center Blade    | (9) Mower Belt       | (12) Outer Blade  |

The power is transmitted from mid-PTO to blades as follows:

■ **Center Blade**

Mid-PTO Shaft (5) → Universal Joint (4) → Pinion Shaft (3) → Bevel Gear (1) → Bevel Gear (2) → Bevel Gear Shaft (8) → Center Blade (6)

■ **Outer Blade**

Mid-PTO Shaft (5) → Universal Joint (4) → Pinion Shaft (3) → Bevel Gear (1) → Bevel Gear (2) → Bevel Gear Shaft (8) → Center Pulley (7) → Mower Belt (9) → Outer Pulley (11) → Blade Shaft (10) → Outer Blade (12)

9Y1210855MOM0001US0

## 2. LIFTING MECHANISM

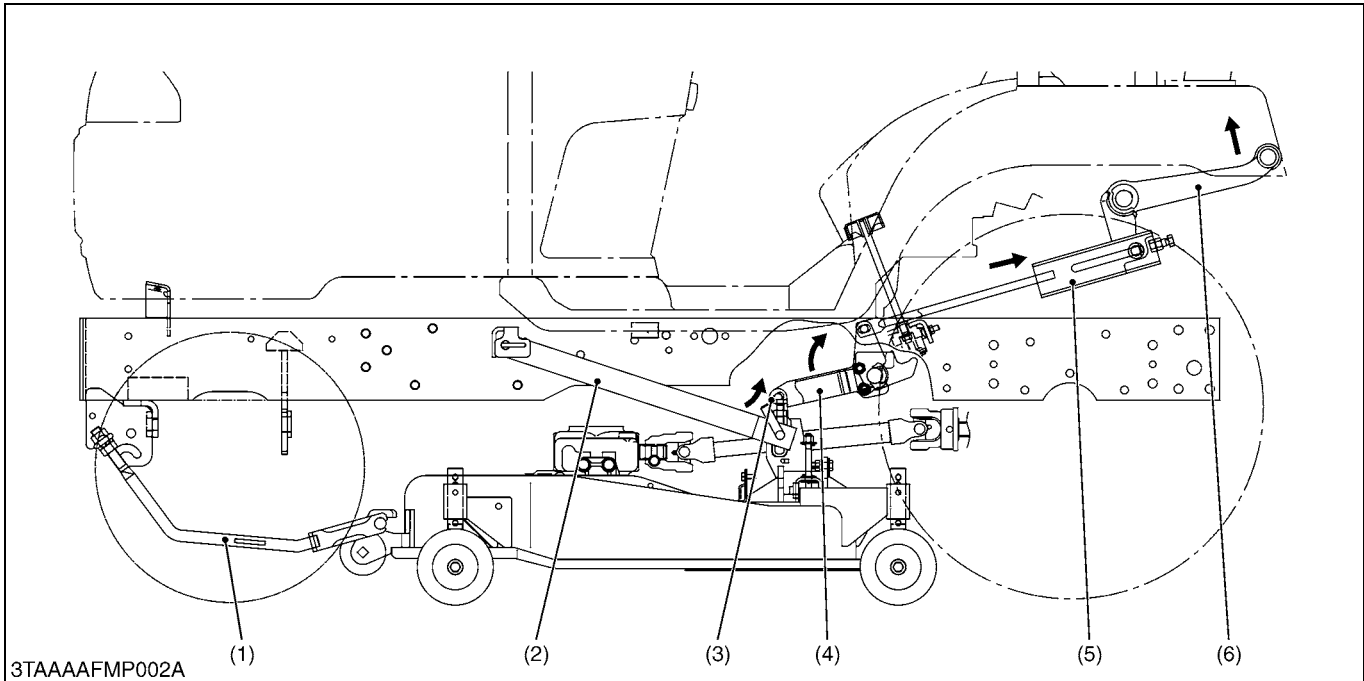

- |                |                         |                         |              |
|----------------|-------------------------|-------------------------|--------------|
| (1) Front Link | (3) Lift Link           | (5) Rear Lift Link (LH) | (6) Lift Arm |
| (2) Rear Link  | (4) Rear Lift Link (RH) |                         |              |

The lifting of mower is performed by the hydraulic system installed on the tractor.

The mower should be kept lift when traveling. When the position control lever is moved to "**LIFT**" position, the lift arm (6) is lifted up by the oil pressure of hydraulic system, and the rear lift link (LH) (5) is pulled rearward.

Therefore, rear lift links (4), (5) rotate and the mower is lifted by the lift links (3) and rear links (2).

As this link system is a parallel linkage, the mower can be kept parallel at every position.

**CAUTION**

- Never operate mower in transport position.

9Y1210855MOM0002US0

### 3. SELF-BALANCER SYSTEM

This system reduces the stepped differences in cutting height when mowing rolling terrain.

9Y1210855MOM0003US0

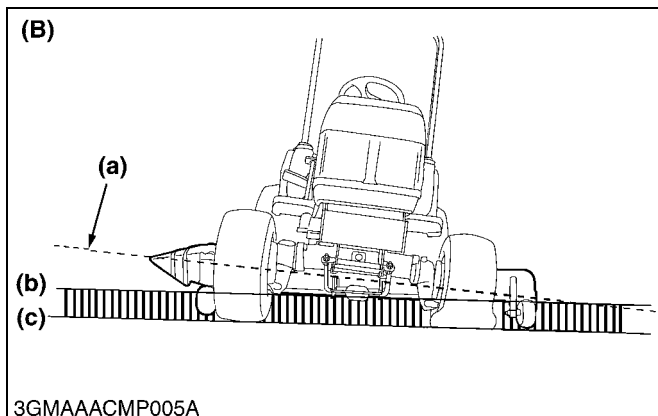
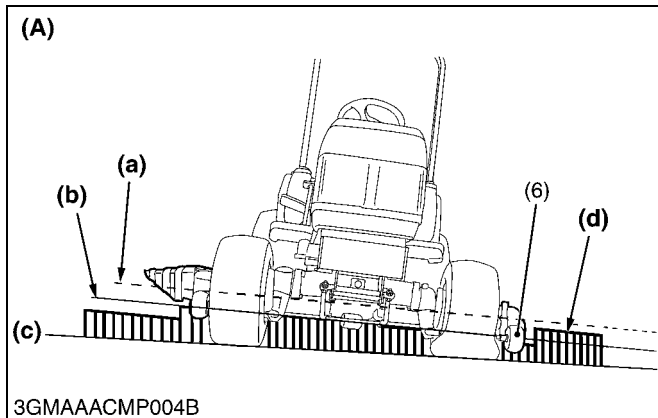
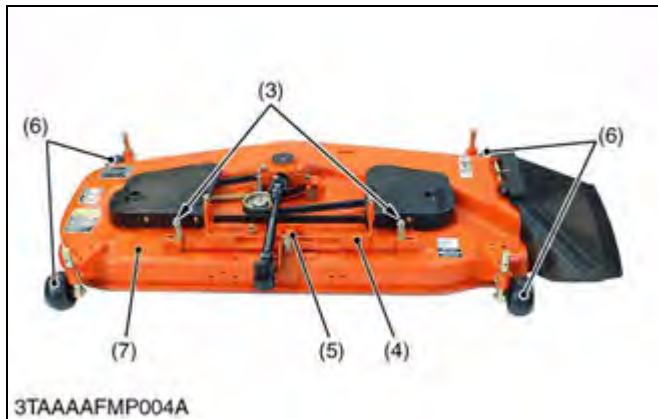
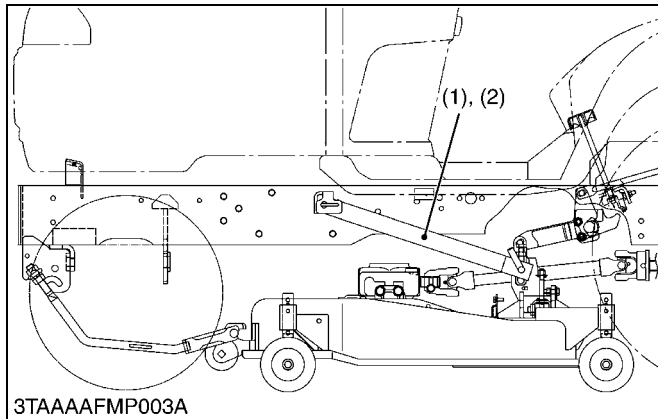

■ **Self-Balancer**

1. The mower deck is held in place via the balancer plate (4) and the support by the rear link (1), (2).
2. The mower deck is suspended by, and is tilted to the right and left by, the balancer support (5). The balancer springs (3) at both sides adjust themselves for suitable tension to keep the mower deck out of excessive tilt.

■ **Without Self-Balancer Type (A)**

- When working on a wavy ground, the tractor itself, with the mower deck, goes along the curves of the terrain. If not equipped with the self-balancer, the tractor tends to tilt itself greater than the ground's waves by its own weight. This may cause an uneven mowing. The wider the mower is, the more unevenness is caused.

■ **With Self-Balancer Type (B)**

- When working on a wavy ground, the tractor itself goes along the curves of the terrain like with the tractor that is not equipped with the self-balancer. The balancer springs (3), however, serve to keep the mower deck in parallel with the ground's curves until the anti-scalp roller (6) comes in contact with the ground.
- If the tractor temporarily tilts itself more than the ground's slope or the like, the anti-scalp roller (6) touches the ground. Now the mower deck is brought back in parallel with the ground by the counter force of the roller (6) just hitting the ground as well as the tension of the balancer springs (3). This helps reduce an uneven mowing.

■ **NOTE**

- **Always keep the anti-scalp roller with specified position (Refer to Operator's Manual).**

- |                       |                           |
|-----------------------|---------------------------|
| (1) Rear Link (RH)    | (A) Without Self-Balancer |
| (2) Rear Link (LH)    | (B) With Self-Balancer    |
| (3) Balancer Spring   | (a) Tilt: Tractor         |
| (4) Balancer Plate    | (b) Tilt: Mower Deck      |
| (5) Balancer Support  | (c) Ground                |
| (6) Anti-scalp Roller | (d) Grass                 |
| (7) Mower Deck        |                           |

9Y1210855MOM0004US0

# SERVICING

## CONTENTS

- 1. TROUBLESHOOTING.....7-S1
- 2. SERVICING SPECIFICATIONS .....7-S2
- 3. TIGHTENING TORQUES .....7-S3
- 4. SETTING UP MOWER .....7-S4
  - [1] RCK48-18BX, RCK54-23BX, RCK60B-23BX, RCK48P-18BX, and RCK54P-23BX .....7-S4
  - [2] RCK54D-26BX, RCK60D-26BX .....7-S7
- 5. CHECKING AND ADJUSTING .....7-S13
  - [1] MOWER ADJUSTMENT .....7-S13
  - [2] CHECKING MOWER BLADE AND BELT .....7-S17
- 6. DISASSEMBLING AND SERVICING .....7-S20
  - [1] DISASSEMBLING AND ASSEMBLING .....7-S20
  - [2] SERVICING .....7-S27

# 1. TROUBLESHOOTING

Symptom	Probable Cause	Solution	Reference Page
<b>Blade Does Not Turn</b>	Mid-PTO system malfunctioning	Check transmission	2-S39
	Mower belt broken	Replace mower belt	7-S18
<b>Blade Speed Is Slow</b>	Mower belt loosen	Replace mower belt or tension spring	7-S18
	Grass clogged	Remove grass	–
	Cup washer flattened out or worn	Replace cup washer	7-S20
	Engine rpm too low	Mow at full throttle, check and reset engine rpm	–
<b>Cutting Is Poor</b>	Mower blade worn or broken	Sharpen or replace mower blade	7-S20
	Mower blade screw loosen	Retighten mower blade screw	7-S20
	Cutting height improper	Adjust cutting height	7-S13 to 7-S16
	Ground speed too fast	Slow-down	–
	Low tire inflation	Add air to correct	G-64
	Anti-scalp rollers not adjusted correctly	Adjust anti-scalp rollers	7-S16
<b>Mower Is Not Lifted</b>	Linkage system broken	Replace linkage system	7-S13
	Trouble of hydraulic system	Check hydraulic system	–

9Y1210855MOS0001US0

## 2. SERVICING SPECIFICATIONS

Item		Factory Specification	Allowable Limit
Stopper and Rear Link	Clearance	0 to 0.5 mm 0 to 0.01 in.	—
Front Tip and Rear Tip of Blade	Difference	0.0 to 5.0 mm 0.0 to 0.20 in.	—
Left Tip and Right Tip of Blade	Difference	Less than 3 mm 0.12 in.	—
Balancer Spring	Length	55.0 mm 2.17 in.	—
Input Shaft (without Mower Belt)	Turning Torque	Less than 0.7 N·m 0.07 kgf·m 0.52 lbf·ft	—
Bevel Gears in Gear Box [RCK48-18BX, RCK54-23BX, RCK60B-23BX, RCK54D-26BX and RCK60D-26BX]  [RCK48P-18BX and RCK54P-23BX]	Backlash	0.10 to 0.20 mm 0.0040 to 0.0078 in.	0.40 mm 0.016 in.
	Backlash	0.13 to 0.25 mm 0.0051 to 0.0098 in.	0.40 mm 0.016 in.

9Y1210855MOS0002US0

### 3. TIGHTENING TORQUES

Tightening torques of screws, bolts and nuts on the table below are especially specified.  
 (For general use screws, bolts and nuts: Refer to "5. TIGHTENING TORQUES" on page G-13.)

**[RCK48-18BX, RCK54-23BX, RCK60B-23BX, RCK54D-26BX and RCK60D-26BX]**

Item	N·m	kgf·m	lbf·ft
Gear box mounting screw	78 to 90	7.9 to 9.2	58 to 66
Mower blade screw	103 to 117	10.5 to 12.0	76.0 to 86.7
Center pulley holder bolt and nut	78 to 90	7.9 to 9.2	58 to 66
Outer pulley mounting nut	197 to 225	20.0 to 23.0	145 to 166
Gear box bracket mounting bolt and nut	78 to 90	7.9 to 9.2	58 to 66
Pulley boss mounting nut	24 to 27	2.4 to 2.8	18 to 20
Outer pulley holder mounting bolt and nut (RCK48-18BX)	48.0 to 55.9	4.9 to 5.7	35.4 to 41.2
Outer pulley holder mounting bolt and nut (RCK54-23BX, RCK60B-23BX, RCK54D-26BX and RCK60D-26BX)	78 to 90	7.9 to 9.2	58 to 66

**[RCK48P-18BX and RCK54P-23BX]**

Item	N·m	kgf·m	lbf·ft
Mower blade screw	103 to 117	10.5 to 12.0	76.0 to 86.7
Gear box screw	24 to 27	2.4 to 2.8	17 to 20
Gear box mounting screw (for aluminum gear case)	39 to 44	4.0 to 4.5	29 to 33
Gear box bracket mounting bolt and nut	78 to 90	7.9 to 9.2	58 to 67
Center pulley holder bolt and nut	78 to 90	7.9 to 9.2	58 to 67
Outer pulley mounting nut	167 to 186	17.0 to 19.0	123 to 137
Outer pulley holder mounting bolt and nut	48.0 to 55.9	4.9 to 5.7	35.4 to 41.2

9Y1210855MOS0003US0

# 4. SETTING UP MOWER

## [1] RCK48-18BX, RCK54-23BX, RCK60B-23BX, RCK48P-18BX, and RCK54P-23BX

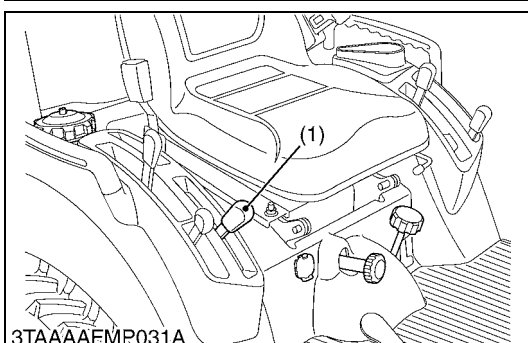
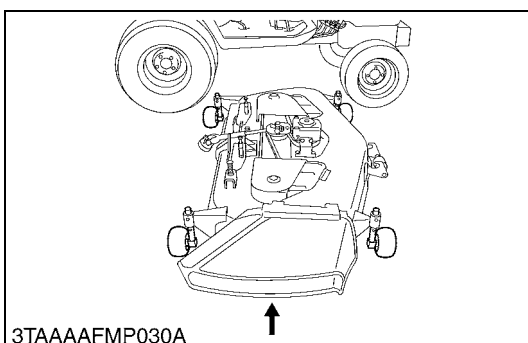
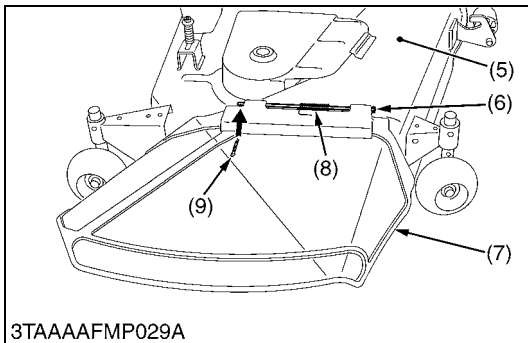
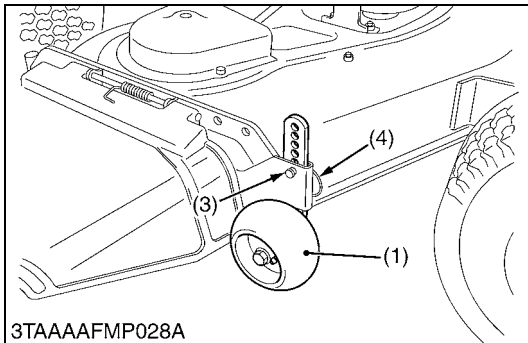
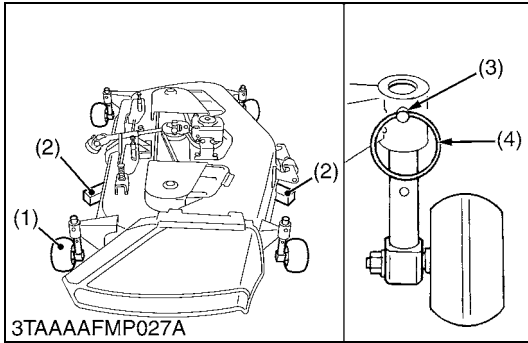

### Assembling Mower

1. Place the mower on blocks as illustrated.  
Turn the anti-scalp rollers sideways and attach to the arms of the deck at the upper position with clevis pins and snap rings. Remove the blocks. (RCK60B-23BX, RCK54P-23BX and RCK54-23BX)
2. Attach the front anti-scalp rollers to the deck with clevis pins and snap rings. (RCK48P-18BX and RCK48-18BX)

### **⚠ DANGER**

To avoid serious injury or death:

- Do not operate the mower without the discharge deflector properly in position.
3. Attach the discharge to the deck with the spring, discharge pin and cotter pin.
  4. Secure the spring to the discharge deflector as illustrated.

- |                       |                         |
|-----------------------|-------------------------|
| (1) Anti-scalp Roller | (6) Discharge Pin       |
| (2) Block             | (7) Discharge Deflector |
| (3) Clevis Pin        | (8) Spring              |
| (4) Snap Ring         | (9) Cotter Pin          |
| (5) Deck              |                         |

9Y1210855MOS0004US0

### Setting Mower

### **⚠ CAUTION**

- Park the tractor on a firm, flat and level surface, set the parking brake, stop the engine and remove the key.

1. Start the engine and the hydraulic lever rearward to raise the mower rear link to the highest position.
2. Stop the engine and remove the key.
3. Roll the mower under the tractor from right side.

- (1) Hydraulic Control Lever

9Y1210855MOS0005US0



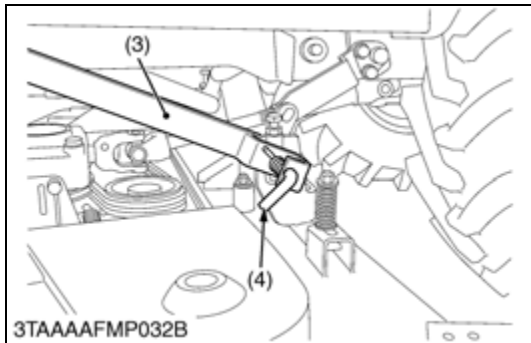
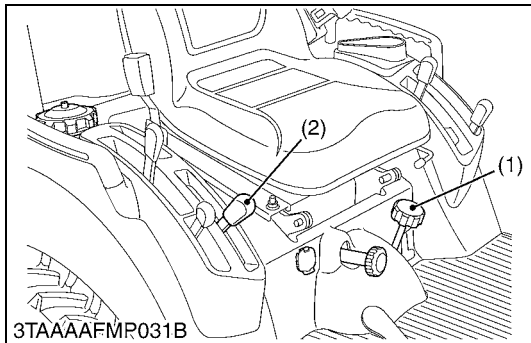
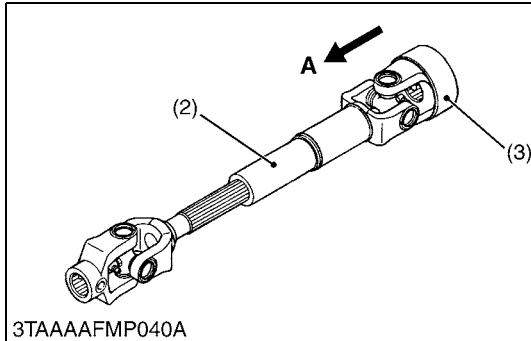
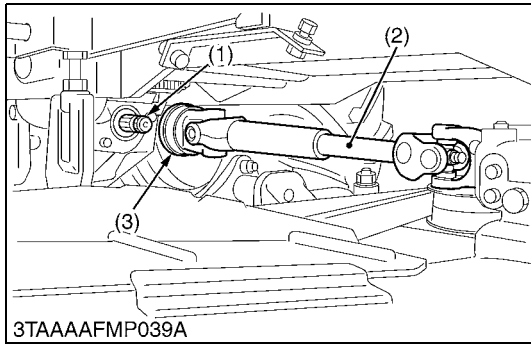

**Universal Joint**

1. Pull back the coupler (3) of the universal joint (2).
2. Push the universal joint (2) onto the mid-PTO shaft (1), until the coupler locks.
3. Slide the universal joint back and forward to make sure the universal joint is locked securely.

**IMPORTANT**

- **Finally, tug on the universal joint to make sure it is locked on the PTO shaft.**

- (1) Mid-PTO Shaft
- (2) Universal Joint
- (3) Coupler

**A: Tug**

9Y1210855MOS0006US0

**Rear Link**

1. Set the cutting height control dial (1) to zero inch position.
2. Operate the tractor's hydraulic control lever (2) forward to lower the mower rear links (3).

Attach the rear links (3) to the mower with the L pins (4).

- (1) Cutting Height Control Dial
- (2) Hydraulic Control Lever
- (3) Rear Link
- (4) L Pin

9Y1210855MOS0007US0

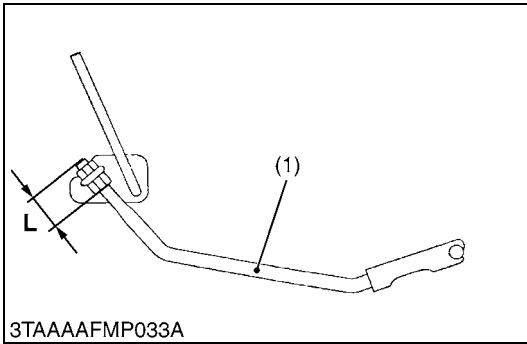

**Front Link**

1. Hook the front link (1) to the front bracket groove (2) as shown in the figure.

**(Reference)**

- Make sure the length "L" of the front link (1) is 47 mm (1.85 in.).

- |                |                          |
|----------------|--------------------------|
| (1) Front Link | (2) Front Bracket Groove |
|----------------|--------------------------|

9Y1210855MOS0008US0

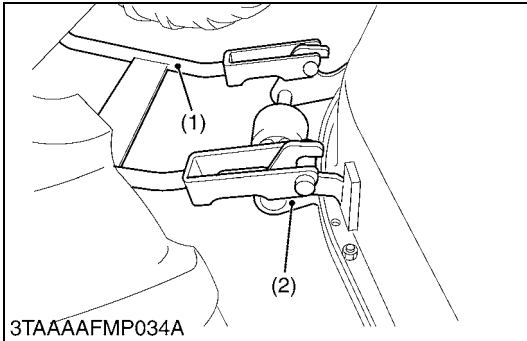

**Mounting Front Link**

1. Position the front lever to the front link bracket.
2. Pull and lock the L pin. Then lower the front lever.
3. Hook the front link to the lever fulcrum, and lift the front lever.
4. Release the L pin to lock the front lever.

■ **NOTE**

- When hooking the front link to the lever fulcrum, normal position of the lever fulcrum groove is open to downward.

■ **IMPORTANT**

- Check that the front lever is locked securely with the L pin.

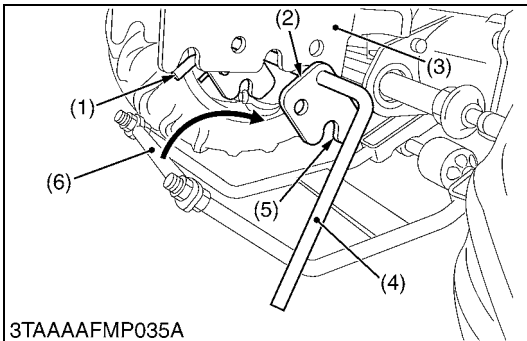

- |                        |                          |
|------------------------|--------------------------|
| (1) L pin              | (4) Front Lever          |
| (2) Lever Fulcrum      | (5) Lever Fulcrum Groove |
| (3) Front Link Bracket | (6) Front Link           |

9Y1210855MOS0009US0

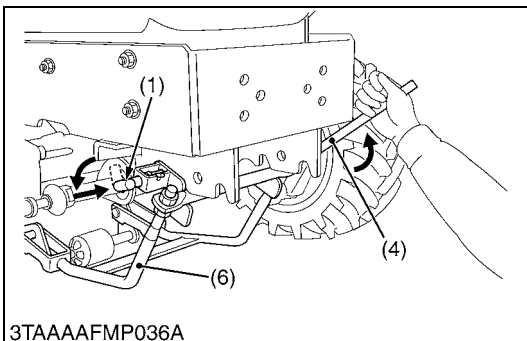

## [2] RCK54D-26BX, RCK60D-26BX

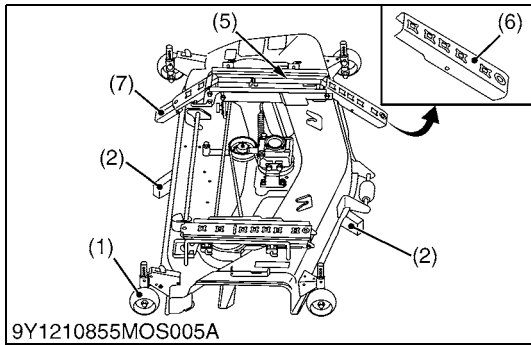

9Y1210855MOS005A

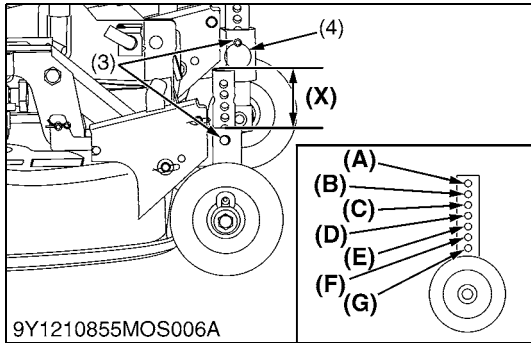

9Y1210855MOS006A

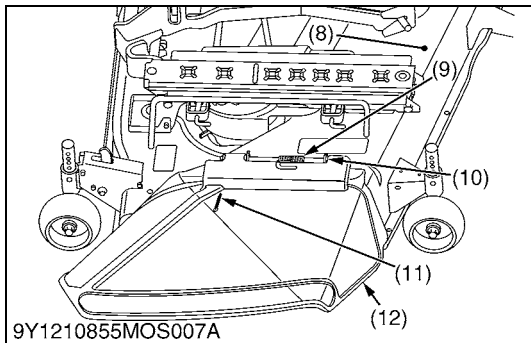

9Y1210855MOS007A

### Assembling Mower

1. Place the mower on blocks as illustrated.
2. Attach all the anti-scalp rollers to the arms of the deck. Put clevis pins from outside and snap rings inside in the "F" position. 4.5 holes (X) must be visible.

### **!** DANGER

To avoid serious injury or death:

- Do not operate the mower without the discharge deflector properly in position.
3. Attach the discharge deflector to the deck with the spring (9), discharge pin (10) and cotter pin (11).  
Secure the spring to the discharge deflector as illustrated.

- |                       |                          |
|-----------------------|--------------------------|
| (1) Anti-scalp Roller | (8) Deck                 |
| (2) Block             | (9) Spring               |
| (3) Clevis Pin        | (10) Discharge Pin       |
| (4) Snap Ring         | (11) Cotter Pin          |
| (5) F Spring          | (12) Discharge Deflector |
| (6) Ramp F            |                          |
| (7) Ramp R            |                          |

9Y1210855MOS0030US0

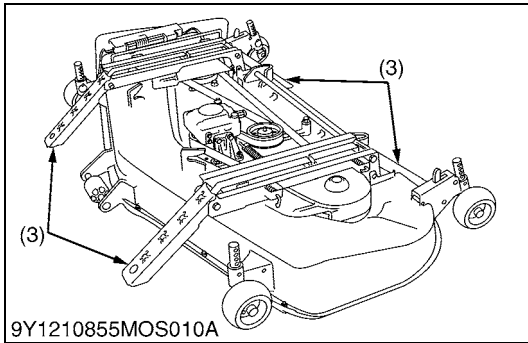
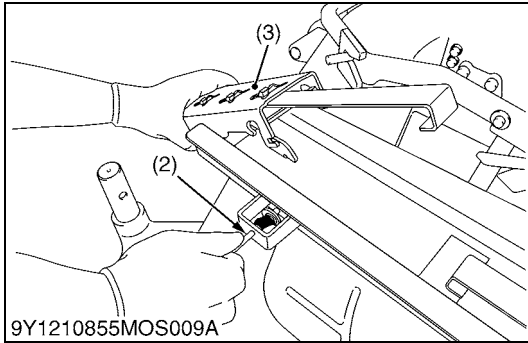
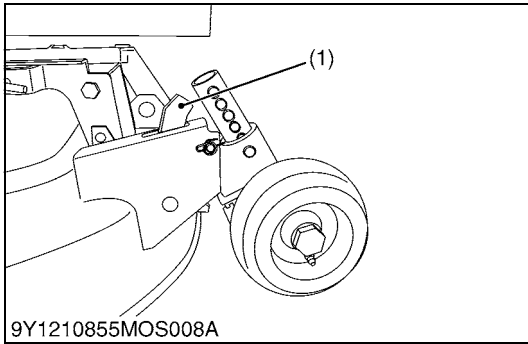

**Setting Mower**

**⚠ WARNING**

To avoid serious injury:

- Park the tractor on a firm, flat and level surface, set the parking brake, stop the engine and remove the key.
- Clean up mower deck, slope and frame link. Make sure there is no debris inside the universal joint.  
**Check all functions work correctly.**

- Remove the front loader, front attachment and 3 point hitch attachment.

1. Adjust all the anti-scalp rollers to the "F" position. 4.5 holes (X) must be visible. (See in "Assembling Mower")
2. Unlock the lever (1) to lift up the rear anti-scalp roller.
3. Pull the L-pin (2) and extend the ramp (3) to front and rear sides.

- (1) Lever  
(2) L-pin

- (3) Ramp

9Y1210855MOS0031US0

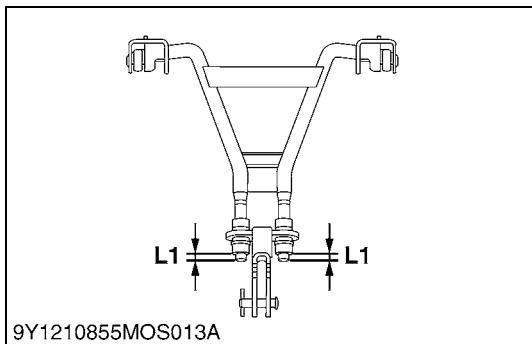
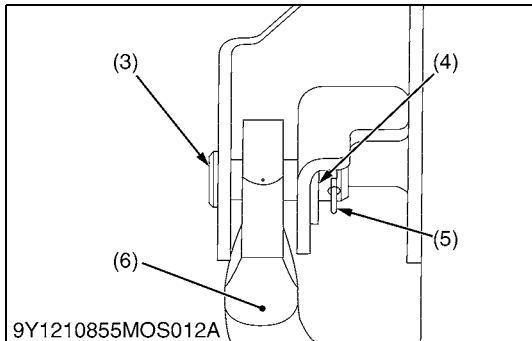
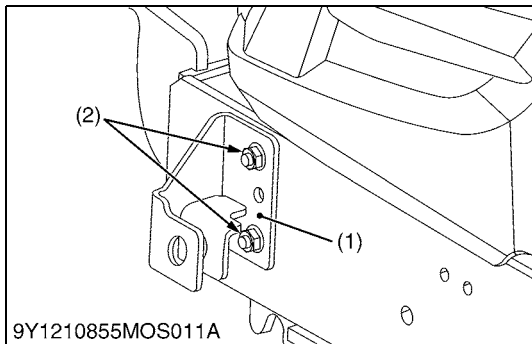

**Front Link**

1. Place all front link and frame link under the tractor.
2. Attach the stay link (1) with the nut (2) on the tractor front frame.

**⚠ CAUTION**

To avoid personal injury:

- Attach the stay link left and right. Do not loosen both left and right side nuts at the same time.
3. Attach the front link (6) to the stay link (1) with joint pin (3), washer (4) and snap pin (5).
  4. Before attaching the mower links, adjust lengths L1 to 22 mm.

Tightening torque	Stay link nut	43.3 to 50.3 N·m 4.4 to 5.1 kgf·m 32 to 37 lbf·ft
-------------------	---------------	---

- (1) Stay Link
- (2) Nut
- (3) Joint Pin
- (4) Washer
- (5) Snap Pin
- (6) Front Link

**L1: 22 mm**

9Y1210855MOS0032US0

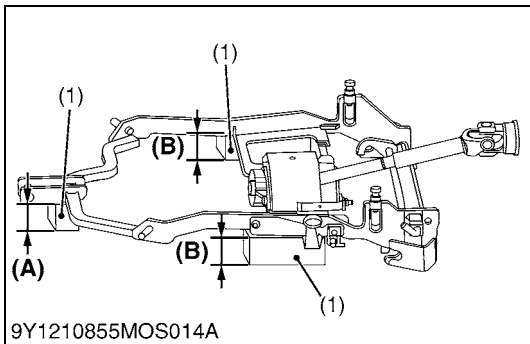

**Frame Link**

1. Place blocks below the frame link if one person does the setting. Heights of blocks are recommended value for attaching.
2. Start engine. Set the cutting height to 0" and lower the frame link. Then stop the engine.
3. Attach the frame link to the link arm.
4. Joint the front link and frame link with joint pin and snap ring.
5. Attach the universal joint to tractor.

- |                     |                      |
|---------------------|----------------------|
| (1) Block           | (A) 160 mm (6.3 in.) |
| (2) Link Arm        | (B) 120 mm (4.7 in.) |
| (3) Universal Joint |                      |

9Y1210855MOS0035US0

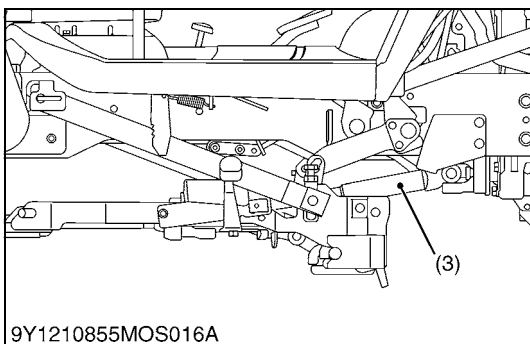
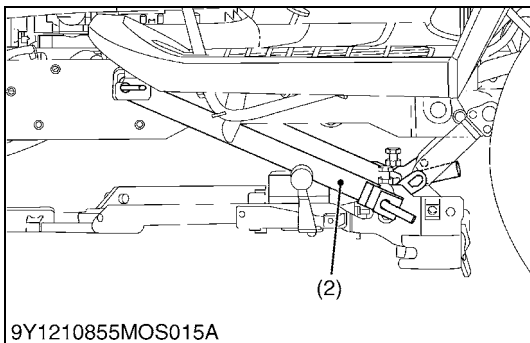

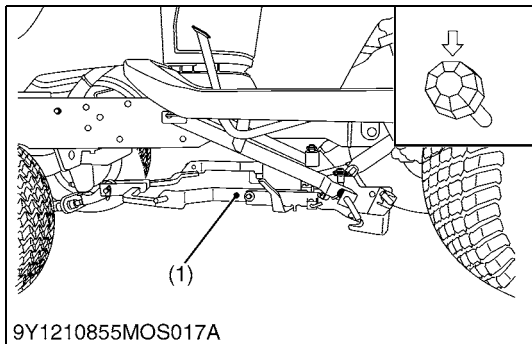

9Y1210855MOS017A

**Setting Tractor**

1. Make sure that the frame link (1) is lifted up to the "TOP" position when tractor is traveling without mower. Stop the tractor behind the mower. Set the parking brake.
2. Set the cutting height to 0" and lower the frame link (1). Then stop the engine.
3. Make sure that the rear lock (2) is unlocked.
4. Make sure that the universal joint (3) is in rear position.
5. Make sure that the frame link (1) is fully down.

- |                                   |        |
|-----------------------------------|--------|
| (1) Frame Link                    | (A) NG |
| (2) Rear Lock                     | (B) OK |
| (3) Lever Guide (Universal Joint) |        |

9Y1210855MOS0036US0

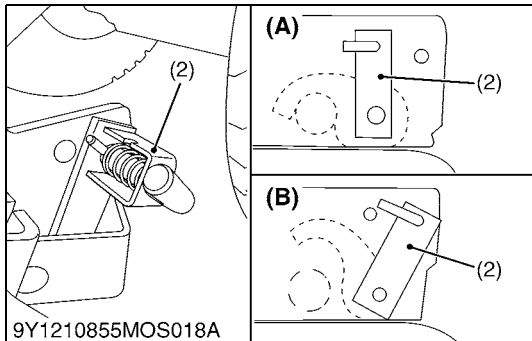

9Y1210855MOS018A

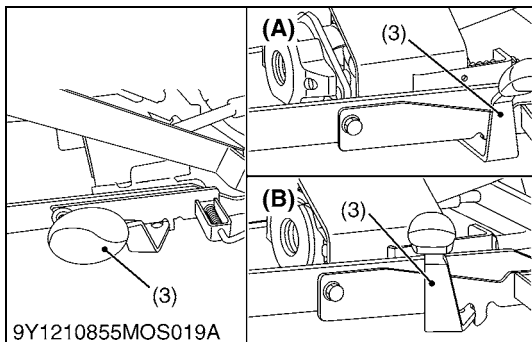

9Y1210855MOS019A

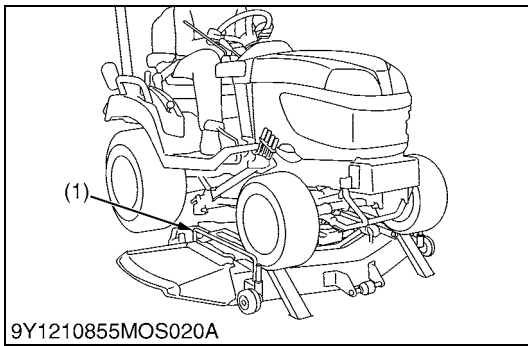

**Mounting Mower**

1. Start the engine and engage 4WD. Set the range gear shift lever to "LOW". Release the parking brake.
2. With the right front tire, make a driving target to the guide (1).
3. Drive over the ramp of mower along the guide (1). Keep the front tire side touching the guide rod.

**⚠ WARNING**

To avoid serious injury:

- If mower moves forward before the tractor rides on, there is less grip between the ground and mower. Change area and try again.

4. Just after the tractor drove over the mower, stop the engine. Make sure frame link is connected to mower.
5. Lock the rear lock (2).

**⚠ WARNING**

To avoid serious injury:

- Double check that frame link is locked to mower deck.

6. Set the PTO select lever to "Rear-PTO" position.
7. Connect the universal joint by the lever guide (3).
8. Lock the lever guide by the lock lever (4).

**⚠ WARNING**

To avoid serious injury:

- Double check that lever guide is locked.

9. Set the PTO select lever to "Mid-PTO" position.
10. Put front and rear ramps (5) back to the ramp bracket (6). Lock the L-pin (7).
11. Start the engine. Lift up the mower to the "TOP" position. Lock the dial gauge and set the parking brake. And then, stop the engine.
12. Lock the rear anti-scalp roller (8).
13. Adjust the anti-scalp roller (8). See "CUTTING HEIGHT" in "Checking and Adjusting" section for further information.

- |                       |            |
|-----------------------|------------|
| (1) Guide             | (A) Engage |
| (2) Rear Lock         | (B) OK     |
| (3) Lever Guide       |            |
| (4) Lever Lock        |            |
| (5) Ramp              |            |
| (6) Ramp Bracket      |            |
| (7) L-Pin             |            |
| (8) Anti-Scalp Roller |            |

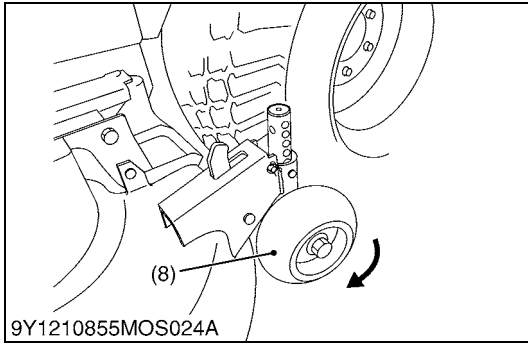
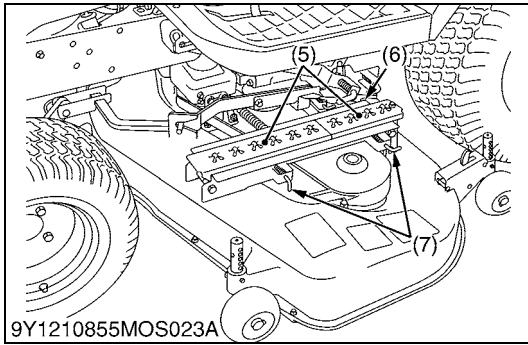
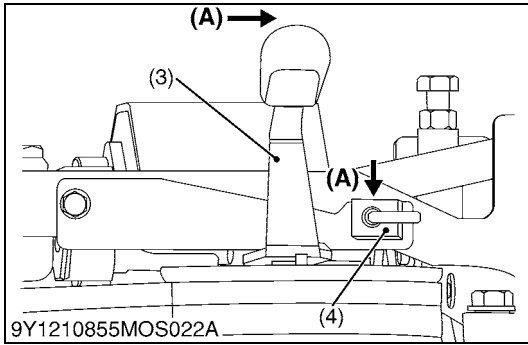
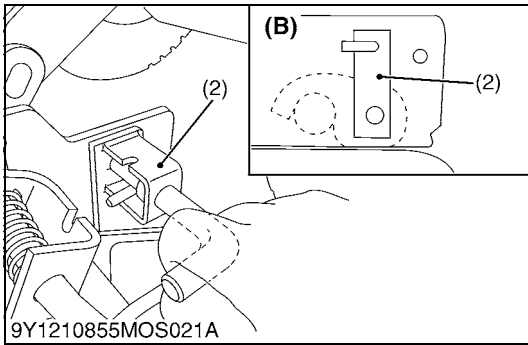

9Y1210855MOS0037US0



# 5. CHECKING AND ADJUSTING

## [1] MOWER ADJUSTMENT

### WARNING

To avoid serious injury:

- Park the tractor on a firm, flat and level surface and set the parking brake.
- Stoop the engine, remove the key, and allow the blades to stop before making adjustments.
- Wear heavy gloves or wrap end of blade with a rag when you handle blades.
- Before starting the engine, make sure that all levers (including auxiliary control levers) are in their neutral positions, that the parking brake is engaged, and that both the clutch and the Power Take-Off (PTO) are disengaged (OFF).

9Y1210855MOS0010US0

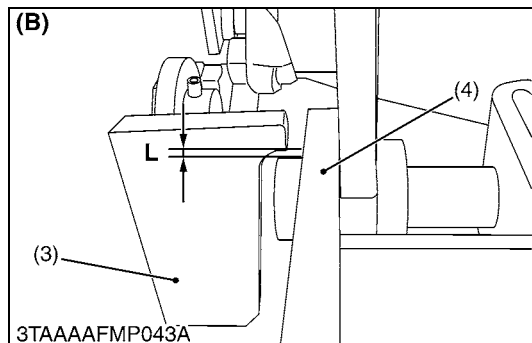
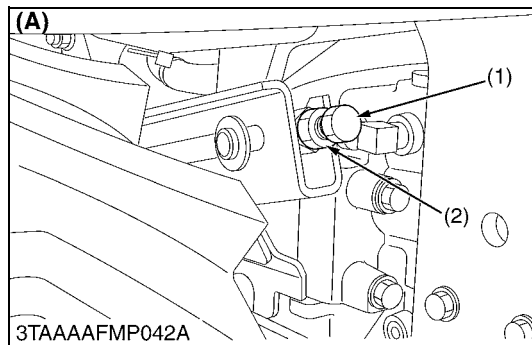
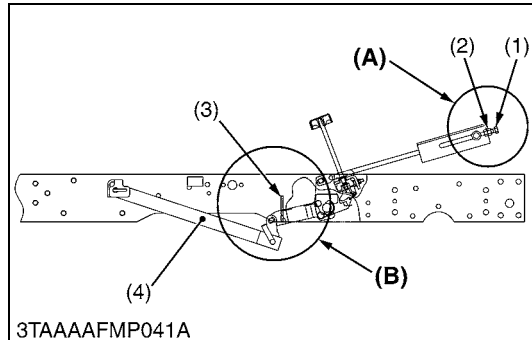

### Adjusting Mower Link

#### ■ IMPORTANT

Readjustment is necessary after following situation:

- Gear box is disassembled for maintenance.
  - Attach different drive over mower deck.
  - Re-attach frame link.
1. Tire pressure must be correct.
  2. Move the hydraulic control lever rearward to raise the mower to the highest position.
  3. Stop the engine and remove the key.
  4. Adjust the left side links with bolt so that the clearance "L" is as follows.

Clearance "L" between stopper and rear link	Factory specification	0 to 0.5 mm 0 to 0.01 in.
---	-----------------------	------------------------------

- (1) Bolt
- (2) Lock Nut
- (3) Stopper
- (4) Rear Link

**L: 0 to 0.5 mm (0 to 0.01 in.)**  
**(A) Adjustment Point**  
**(B) Check Point**

9Y1210855MOS0011US0

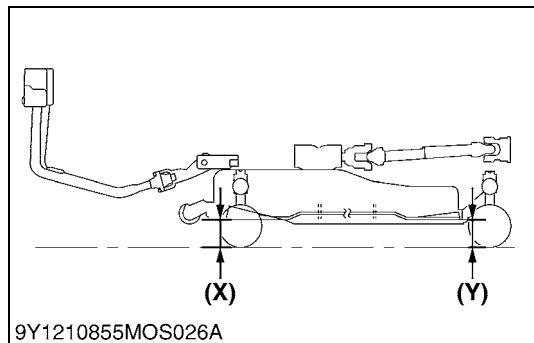
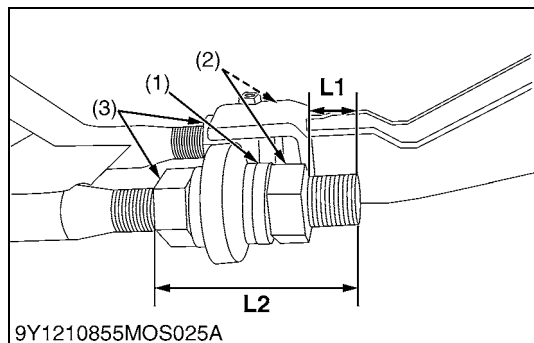

**Adjusting Front and Rear Cutting Height [RCK54D-26BX and RCK60D-26BX]**

1. Park the machine on a firm, flat and level surface and set the parking brake.
2. Tire pressure must be correct. (See "[1] TIRE PRESSURE" in "GENERAL" section.)
3. Turn the cutting height control dial to "2.0" and keep clearance between the anti-scalp rollers and ground from 6 to 13 mm (0.25 to 0.5 in.) as shown in "CUTTING HEIGHT" in "CHECKING AND ADJUSTING" section.
4. Make sure the level of the mower blades is adjusted as shown below. Align the ends of the right side blade towards the front and rear of the machine. Turn blade by hand in either direction. Adjust "L1" of front links with lock nuts so that "A" is 0 to 5 mm (0 to 0.2 in.) "A" = (Y) - (X)
5. To adjust "L1", loose (2) nuts then turn (3) nuts. Rotate both (3) nuts same time to set LH and RH "L2" in even length. Tighten (2) nuts to lock securely.

Tightening torque	Front link lock nut	60 to 70 N·m 6.2 to 7.1 kgf·m 45 to 51 lbf·ft
-------------------	---------------------	---

- (1) Spring Lock Washer (3) Lock Nut  
(2) Lock Nut

9Y1210855MOS0039US0

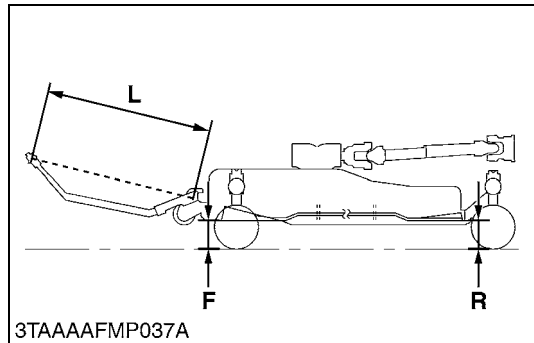
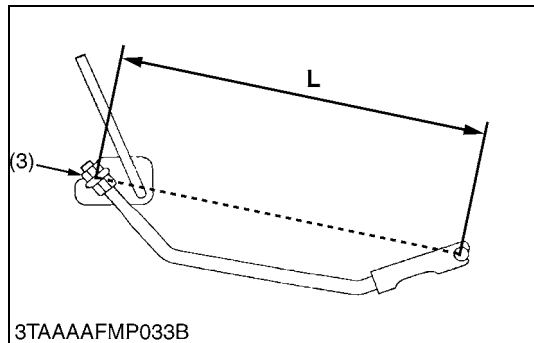
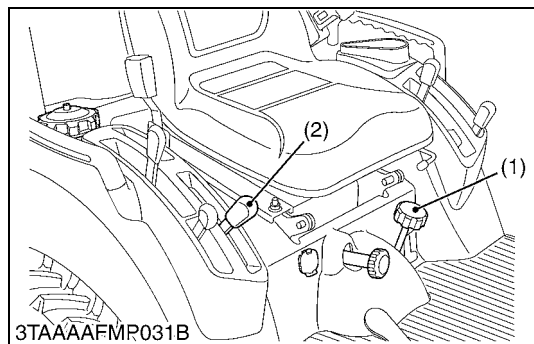

**Adjusting Front and Rear Cutting Height [RCK60B-23BX, RCK54-23BX, RCK48-18BX, RCK54P-23BX and RCK48P-18BX]**

1. Tire pressure must be correct.
2. Make sure the level of the mower blades is adjusted as shown below. Then tighten the lock nuts securely.
3. Turn the cutting height control dial to "2.0" and the anti-scalp roller's height to keep clearance between rollers and ground from 6 to 13 mm (0.25 to 0.5 in.).
4. Turn right blade by hand parallel to direction of travel.
5. Adjust "L" of front links with lock nuts so that "A" is 0 to 5 mm (0 to 0.2 in.) "A" = "R" - "F".
6. If the difference between front tip and rear tip of blade is not within the factory specification, adjust the length "L" of front link with lock nut (3). The height of rear blade tip "R" should be bigger than the front.

Difference "R" - "F" ("R" ≥ "F") between front tip and rear tip of blade	Factory specification	0.0 to 5.0 mm 0.0 to 0.20 in.
--	-----------------------	----------------------------------

- (1) Cutting Height Control Dial L: Length of Front Link  
(2) Hydraulic Control Lever F: Height of Blade Tip (Front)  
(3) Lock Nut R: Height of Blade Tip (Rear)

9Y1210855MOS0012US0

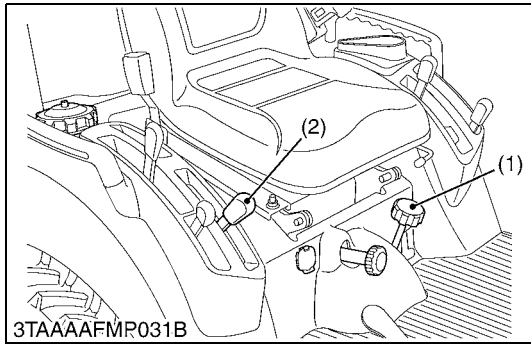

3TAAAFMP031B

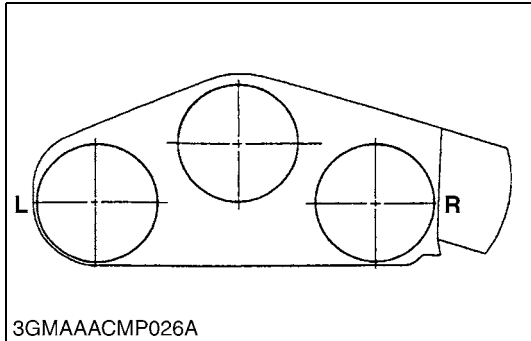

3GMAAACMP026A

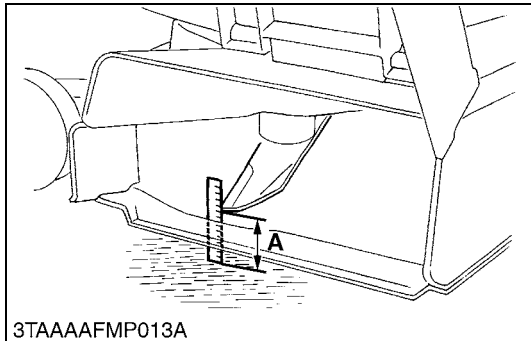

3TAAAFMP013A

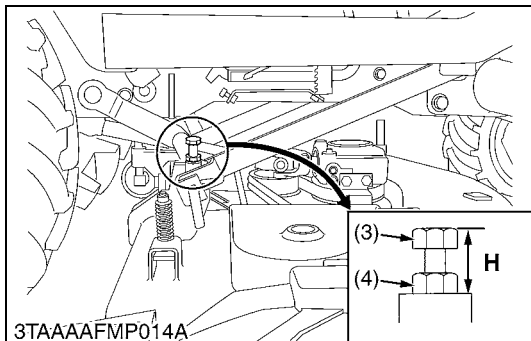

3TAAAFMP014A

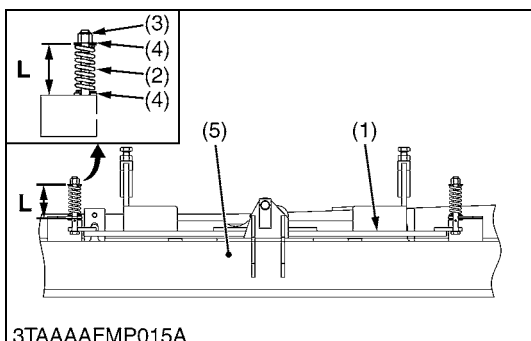

3TAAAFMP015A

### Adjusting Left and Right Cutting Height

1. Tire pressure must be correct.
2. Operate the hydraulic control lever (2) rearward to raise the mower deck to the highest position.
3. Stop the engine and remove the key.
4. Turn the cutting height control dial to the desired height.
5. Set the anti-scalp roller's height to keep clearance between rollers and ground from 6 to 13 mm (0.2 to 0.5 in.).
6. Lower the mower deck by moving the hydraulic control lever forward.
7. Turn left blade by hand parallel to tractor axle and turn right blade parallel to axle to measure from the outside blade tip at "L" and "R" to the level surface.
8. The difference between measurement should be less than 3 mm (0.12 in.).
9. If the difference between measurement is more than 3 mm (0.12 in.), loosen the lock nut of the left side.
10. Adjust the cutting height fine turning bolts so that the difference between measurement "L" and "R" is less than 3 mm (0.12 in.). Then lock the nut.

Difference "L" - "R" between left tip and right tip of blade	Factory specification	Less than 3 mm 0.12 in.
--	-----------------------	-------------------------

- (1) Cutting Height Control Dial
  - (2) Hydraulic Control Lever
  - (3) Cutting Height Fine Turning Bolt
  - (4) Lock Nut
- L: Left Blade Measurement Position**
  - R: Right Blade Measurement Position**
  - A: Blade Height**

9Y1210855MOS0013US0

### Adjusting Self-Balance Suspended Linkage [RCK60B-23BX Only]

1. Check the length "L" of balancer spring (2).
2. If the length "L" is not within the factory specification, adjust the length of balancer spring (2) with lock nut (3).

■ **NOTE**

- Check the left and right cutting height difference after adjusting the self-balancer linkage.

Balancer spring length "L" (Right and left)	Factory specification	55.0 mm 2.17 in.
---	-----------------------	------------------

- (1) Self-Balancer
  - (2) Balancer Spring
  - (3) Lock Nut
  - (4) Plain Washer
  - (5) Mower Deck
- L: Balancer Spring Length**

9Y1210855MOS0014US0

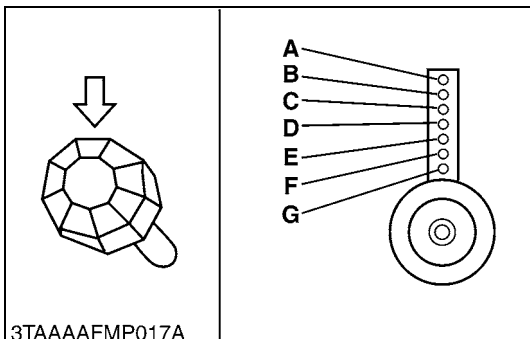
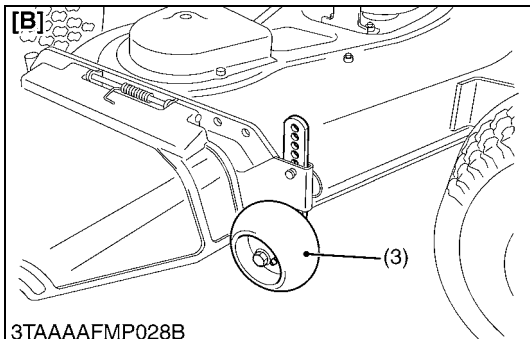
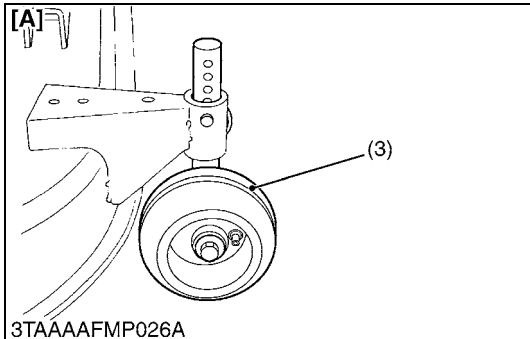
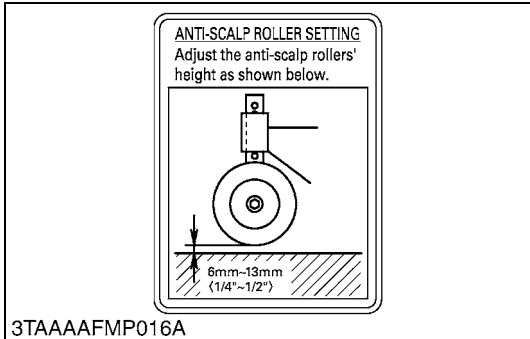
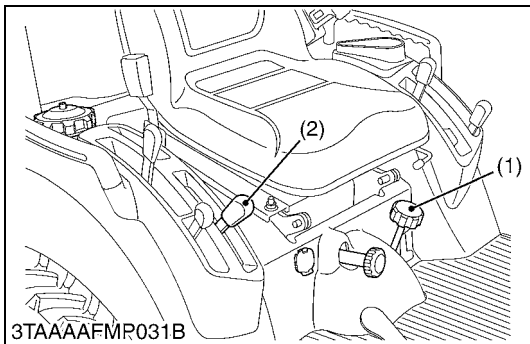

**Cutting Height**



To avoid serious injury or death:

- Never operate the mower in transport position.

**IMPORTANT**

- (for self-balance suspended linkage)

To reduce the stepped difference in cutting height when mowing rolling terrain, follow the procedure below.

1. To set the cutting height, move the hydraulic control lever rearward to raise the mower to the highest position. Turn the cutting height control dial (1) to adjust height.
2. Set the anti-scalp roller's (3) height as shown to keep clearance between rollers and ground from 6 to 13 mm (0.2 to 0.5 in.).
3. Lower the mower deck by moving the hydraulic control lever (2) forward.
4. Use the higher settings for mowing in a rough area or when mowing tall grass. Lower settings should be used only for smooth lawns where short grass is desired.

**IMPORTANT**

To reduce the stepped differences in cutting height when mowing rolling terrain, follow the procedure below.

5. To set the cutting height, move the hydraulic control lever (2) rearward to raise the mower to the highest position. Turn the cutting height control dial to adjust height.
6. Set the anti-scalp roller's (3) position as shown to have the same cutting height.

Dial (Cutting Height)	Anti-scalp Roller
25 mm (1.0 in.), 32 mm (1.25 in.)	G
38 mm (1.5 in.), 45 mm (1.75 in.)	F
51 mm (2.0 in.), 57 mm (2.25 in.)	E
64 mm (2.5 in.), 70 mm (2.75 in.)	D
76 mm (3.0 in.), 83 mm (3.25 in.)	C
89 mm (3.5 in.), 95 mm (3.75 in.)	B
102 mm (4.0 in.)	A

- (1) Cutting Height Control Dial
- (2) Hydraulic Control Lever
- (3) Anti-scalp Roller

[A] RCK54-23BX, RCK54P-23BX, RCK60B-23BX, RCK54D-26BX and RCK60D-26BX

[B] RCK48P-18BX and RCK48-18BX

9Y1210855MOS0015US0

## [2] CHECKING MOWER BLADE AND BELT

### WARNING

To avoid serious injury or death:

- Be sure to stop the engine and remove the key.
- Blades may be sharp. When you handle blades, wear heavy gloves or wrap end of blade with a rag.
- Be sure to reinstall the removed cover after replacing the belt.

9Y1210855MOS0038US0

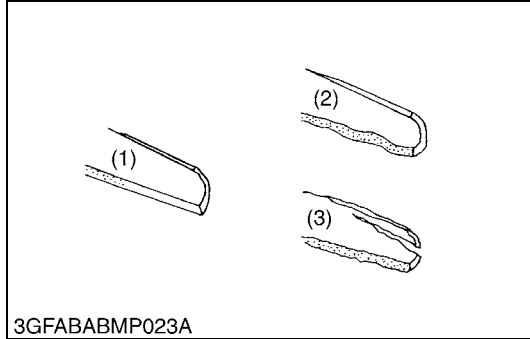

### Checking Mower Blade

1. Check the cutting edge of mower blade.
2. Sharpen the cutting edges, if the mower blades are as shown in figure (2).
3. Replace the mower blades, if they are as shown in figure (3).

#### ■ IMPORTANT

- Never forget to set the dust cover, cup washer(s) and lock washer, when reassembling the mower blades. (See page 7-S20.)

#### ■ NOTE

- To sharpen the mower blades by yourself, clamp the mower blade securely in a vise and use a large mill file along the original bevel.
- To balance the mower blade, place a small rod through the center hole and check to see if the blade balance evenly. File heavy side of the blade until it balance out even.

- (1) New Blade  
(2) Worn Blade

- (3) Cracked Blade

9Y1210855MOS0016US0

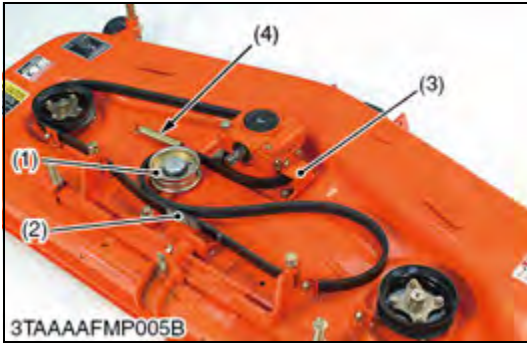
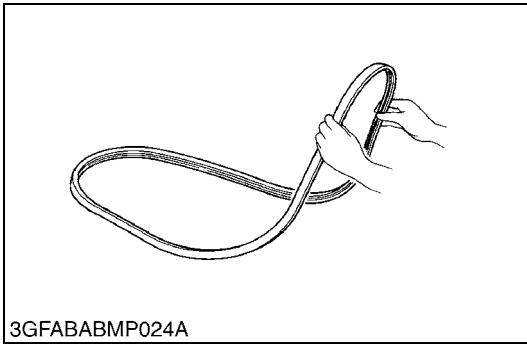

**Checking Mower Belt [RCK48-18BX, RCK54-23BX, RCK60B-23BX, RCK48P-18BX and RCK54P-23BX]**

1. Check to see the mower belt.
2. Replace the mower belt with a new one, if there is found surface split at more than 3 positions.

**(When replacing mower belt)**

1. Dismount the mower from the tractor.
2. Remove the left and right hand belt cover from the mower deck.
3. Clean around gear box.
4. Remove tension spring (4), loosening the belt.
5. Remove gear box bracket (right) (3) which mounts the gear box to the mower deck.
6. Remove the mower belt (2) from the tension pulley (1). Slip the mower belt over the top of the gear box.
7. To install a new belt, reverse the above procedure.

**[RCK48-18BX, RCK54-23BX and RCK60B-23BX]**

Tightening torque	Gear box bracket mounting bolt and nut	78 to 90 N·m 7.9 to 9.2 kgf·m 58 to 66 lbf·ft
	Gear box mounting screw	78 to 90 N·m 7.9 to 9.2 kgf·m 58 to 66 lbf·ft

**[RCK48P-18BX and RCK54P-23BX]**

Tightening torque	Gear box bracket mounting bolt and nut	78 to 90 N·m 7.9 to 9.2 kgf·m 58 to 66 lbf·ft
	Gear box mounting screw (for aluminum gear case)	39 to 44 N·m 4.0 to 4.5 kgf·m 29 to 33 lbf·ft

**■ IMPORTANT**

- **After setting the gear box bracket mounting screws on the deck without tightening, then mount the other screws on the gear box. And finally tighten them.**

- |                    |                              |
|--------------------|------------------------------|
| (1) Tension Pulley | (3) Gear Box Bracket (Right) |
| (2) Mower Belt     | (4) Tension Spring           |

9Y1210855MOS0017US0



# 6. DISASSEMBLING AND SERVICING

## [1] DISASSEMBLING AND ASSEMBLING

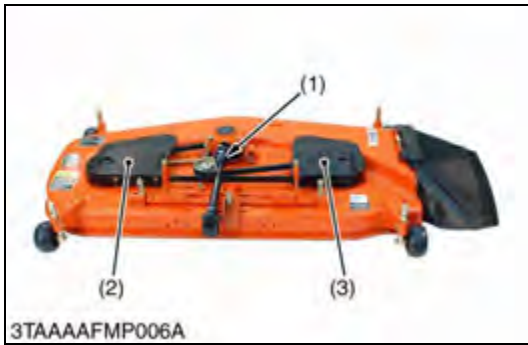

### Universal Joint and Belt Cover [RCK48-18BX, RCK54-23BX, RCK60B-23BX, RCK48P-18BX and RCK54P-23BX]

1. Remove the universal joint screw.
2. Remove the universal joint (1).
3. Remove the left and right belt covers (2), (3).

- (1) Universal Joint
- (2) Belt Cover (Left)
- (3) Belt Cover (Right)

9Y1210855MOS0018US0

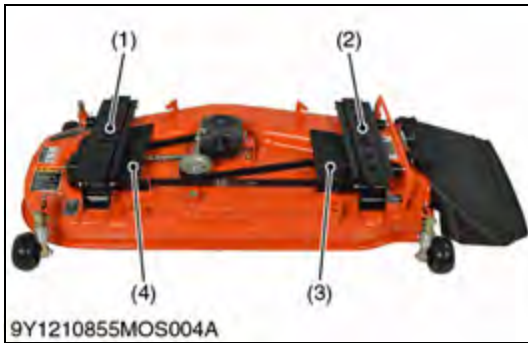

### Ramps and Belt Cover [RCK54D-26BX and RCK60D-26BX]

1. Remove left and right ramp bracket pins.
2. Remove left and right ramps (1), (2).
3. Remove the left and right belt covers (3), (4).

- (1) Ramp (Left)
- (2) Ramp (Right)
- (3) Belt Cover (Right)
- (4) Belt Cover (Left)

9Y1210855MOS0034US0



### Mower Blades (Center Blade and Outer Blades)

1. Turn over the mower.
2. Remove the mower blade screw (5), and remove the lock washer (4), cup washer(s) (3), mower blade (2) and dust cover (1).

■ **NOTE**

- To remove the blade securely, wedge a block of wood between one blade and the mower deck in such position that it will hold the blade safely while loosening or tightening the blade screw.

(When reassembling)

### [RCK48-18BX, RCK54-23BX, RCK48P-18BX and RCK54P-23BX]

- Install the blade in position together with the dust cover and the cup washer. Tighten them up with the screw.

### [RCK60B-23BX, RCK54D-26BX and RCK60D-26BX]

- Install the blade in position together with the dust cover, the lock washer and the 2 cup washers. Tighten them up with the screw.

■ **IMPORTANT**

- Make sure the cup washer is not flattened out or worn, causing blade to slip easily.
- Replace cup washer(s) if either is damaged.

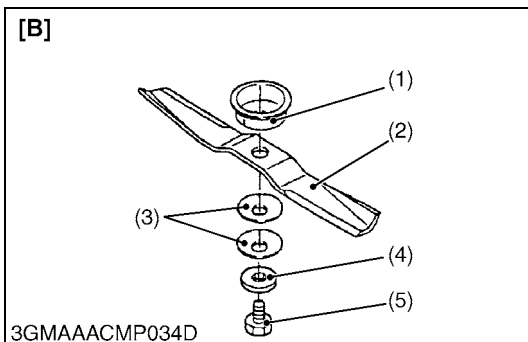
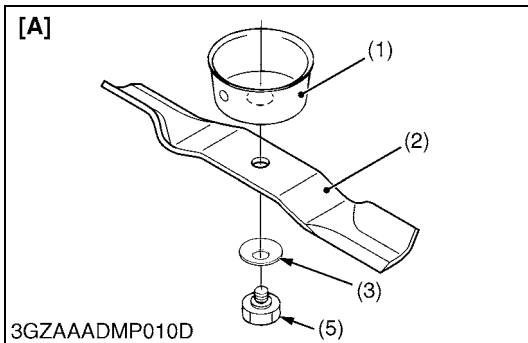

Tightening torque	Mower blade screw	103 to 117 N·m 10.5 to 12.0 kgf·m 76.0 to 86.7 lbf·ft
-------------------	-------------------	---

- (1) Dust Cover
- (2) Mower Blade
- (3) Cup Washer
- (4) Lock Washer
- (5) Mower Blade Screw
- [A] RCK48-18BX, RCK54-23BX, RCK48P-18BX and RCK54P-23BX
- [B] RCK60B-23BX, RCK54D-26BX and RCK60D-26BX
- a: Loosen

9Y1210855MOS0019US0



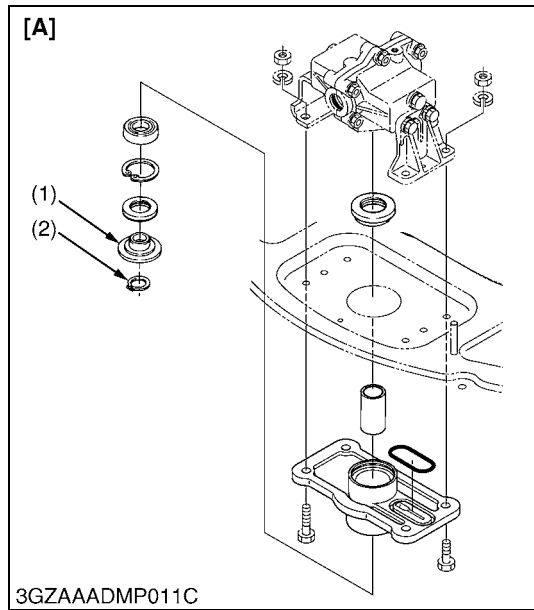

**Blade Boss**

1. Remove the external snap ring (2).
2. Remove the blade boss (1).

- (1) Blade Boss
- (2) External Snap Ring

**[A] RCK48P-18BX and RCK54P-23BX**  
**[B] RCK48-18BX, RCK54-23BX,**  
**RCK60B-23BX, RCK54D-26BX**  
**and RCK60D-26BX**

9Y1210855MOS0020US0

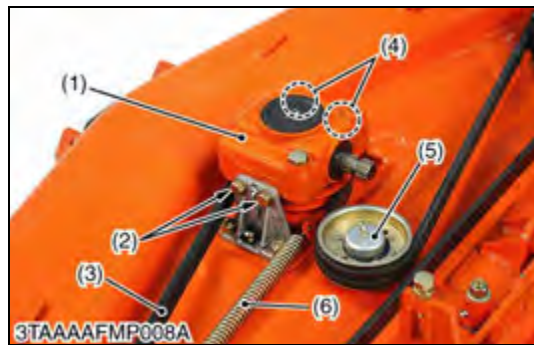
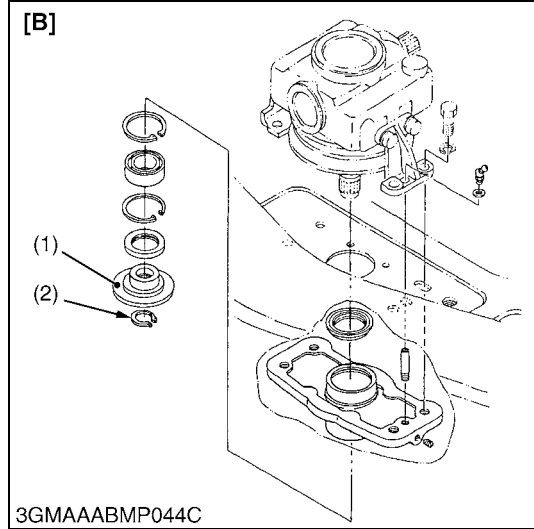

**Gear Box and Mower Belt**

1. Turn over the mower.
2. Remove the mower belt (3) from the tension pulley (5).
3. Remove the left and right gear box mounting screws (2), (4) and remove the gear box (1) from the mower deck.

**(When reassembling)**

- Install the reamer screws (2) at their original positions as shown in the figure.

**[RCK48-18BX, RCK54-23BX, RCK60B-23BX, RCK54D-26BX and RCK60D-26BX]**

Tightening torque	Gear box mounting screw	78 to 90 N·m 7.9 to 9.2 kgf·m 58 to 66 lbf·ft
-------------------	-------------------------	---

**[RCK48P-18BX and RCK54P-23BX]**

Tightening torque	Gear box mounting screw (for aluminum gear box)	39 to 44 N·m 4.0 to 4.5 kgf·m 29 to 33 lbf·ft
-------------------	---	---

- (1) Gear Box
- (2) Gear Box Mounting Screw (Reamer Screw)
- (3) Mower Belt
- (4) Gear Box Mounting Screw
- (5) Tension Pulley
- (6) Tension Spring

9Y1210855MOS0021US0

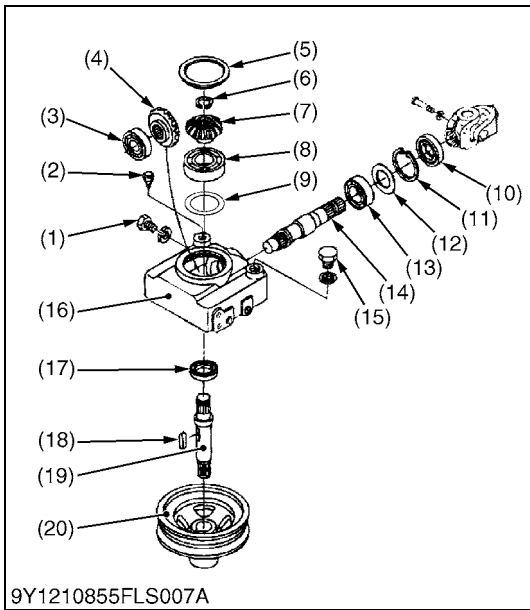

**Disassembling Gear Box [RCK48-18BX, RCK54-23BX, RCK60B-23BX, RCK54D-26BX and RCK60D-26BX]**

1. Remove the drain plug (1), and drain the gear box oil.
2. Remove the center pulley (20) with a puller, and remove the feather key (18) on the bevel gear shaft (19).
3. Remove the gear box cap (5).
4. Remove the oil seal (10), internal snap ring (11) and shim (12).
5. Tap out the pinion shaft (14) with the ball bearing (13), and remove the bevel gear (4).
6. Remove the ball bearing (3) and shims (if installed).
7. Remove the external snap ring (6), and draw out the bevel gear shaft (19).
8. Remove the bevel gear (7), ball bearing (8), shim (9) and oil seal (17).

**(When reassembling)**

- Replace the oil seals (10), (17) and gear box cap (5) with new ones.
- Check the backlash and turning torque.  
If not proper, adjust with the shims.  
(See page 7-S27 and 7-S28.)

- |   |                         |
|---|-------------------------|
| (1) Drain Plug  | (8) Ball Bearing        |
| (2) Breather  | (9) Shim                |
| (3) Ball Bearing  | (10) Oil Seal           |
| (4) 21T Bevel Gear (RCK48-18BX)<br>19T Bevel Gear (RCK54-23BX and<br>RCK54D-26BX) | (11) Internal Snap Ring |
| (5) Gear Box Cap  | (12) Shim               |
| (6) External Snap Ring  | (13) Ball Bearing       |
| (7) 16T Bevel Gear (RCK48-18BX,<br>RCK54-23BX and RCK54D-26BX)                    | (14) Pinion Shaft       |
|   | (15) Oil Filler Plug    |
|   | (16) Gear Box           |
|   | (17) Oil Seal           |
|   | (18) Feather Key        |
|   | (19) Bevel Gear Shaft   |
|   | (20) Center Pulley      |

9Y1210855MOS0022US0

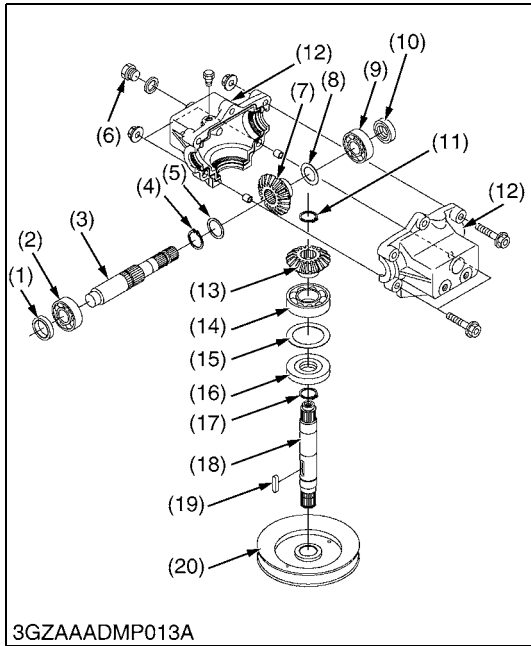

**Disassembling Gear Box [RCK48P-18BX and RCK54P-23BX]**

1. Remove the drain plug (6), and drain the gear box oil.
2. Remove the center pulley (20) with a puller.
3. Remove the gear box.
4. Open the gear box.
5. Remove the input shaft (3) and the blade shaft (18).
6. Disassembling the input shaft (3) and the blade shaft (18).

**(When reassembling)**

- Replace the oil seals (1), (10) and (16) with new ones.
- Check the backlash and turning torque.  
If not proper, adjust with the shims.  
(See page 7-S27 and 7-S28.)
- After cleaning dirty and gear box oil and the gear box surface, apply the liquid gasket.

Tightening torque	Gear box screw	24 to 27 N·m 2.4 to 2.8 kgf·m 17 to 20 lbf·ft
-------------------	----------------	---

- |                      |                       |
|----------------------|-----------------------|
| (1) Oil Seal         | (11) External Circlip |
| (2) Ball Bearing     | (12) Bevel Gear Case  |
| (3) Input Shaft      | (13) Bevel Gear       |
| (4) External Circlip | (14) Ball Bearing     |
| (5) Shim             | (15) Shim             |
| (6) Drain Plug       | (16) Oil Seal         |
| (7) Bevel Gear       | (17) External Circlip |
| (8) Shim             | (18) Blade Shaft      |
| (9) Ball Bearing     | (19) Feather Key      |
| (10) Oil Seal        | (20) Center Pulley    |

9Y1210855MOS0023US0

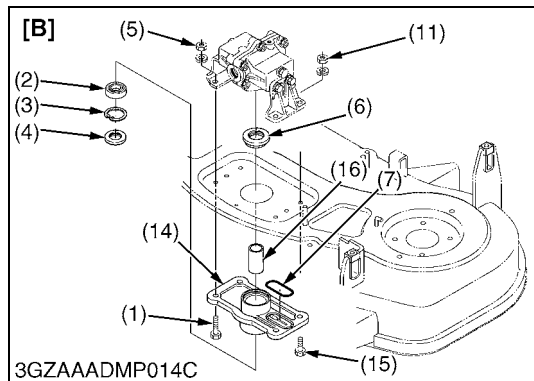
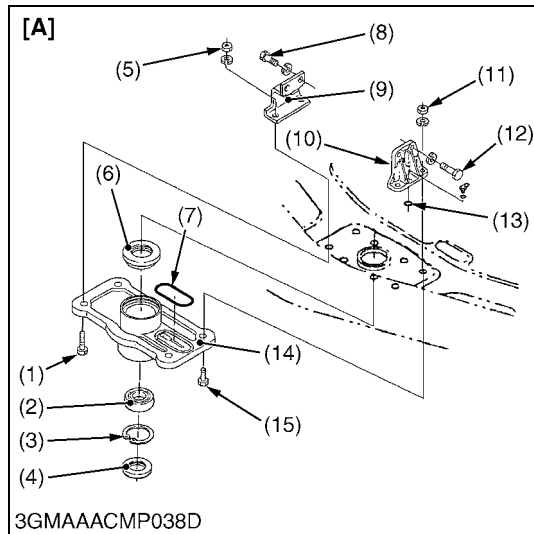

**Center Pulley Holder**

1. Remove the center pulley holder bolt (1), (15) / center pulley nut (5), (11).
2. Remove the upper oil seal (6) and lower oil seal (4).
3. Remove the internal snap ring (3) and ball bearing (2).

**(When reassembling)**

- Replace the oil seals (4), (6) with new ones.
- Install the reamer screw (12) / reamer bolt (15) at their original positions as shown in the figure.
- Be sure to fix the O-rings (7), (13) to the original position.

**NOTE**

- **When reassembling the center pulley holder (14), gear box and gear box bracket (9), (10), tighten the bolts and nuts in the order as below, to prevent the incline the gear box.**
- **Tighten the reamer screw (12) to the gear box first, then tighten the reamer bolts (15) and nut (11) to the center pulley holder (14) with specified torque.**
- **Tighten the gear box screws (8) to the gear box and then tighten the center pulley holder bolts (1) and nut (5) with specified torque.**
- **See page 7-S21 for tightening torque of gear box mounting screw.**

Tightening torque	Center pulley holder bolt and nut	78 to 90 N·m 7.9 to 9.2 kgf·m 58 to 66 lbf·ft
-------------------	-----------------------------------	---

- |  |   |
|--|---|
| <ul style="list-style-type: none"> <li>(1) Center Pulley Holder Bolt</li> <li>(2) Ball Bearing</li> <li>(3) Snap Ring</li> <li>(4) Oil Seal</li> <li>(5) Nut</li> <li>(6) Oil Seal</li> <li>(7) O-ring</li> <li>(8) Gear Box Mounting Screw</li> <li>(9) Gear Box Bracket (Right)</li> <li>(10) Gear Box Bracket (Left)</li> <li>(11) Nut</li> </ul> | <ul style="list-style-type: none"> <li>(12) Gear Box Reamer Screw</li> <li>(13) O-ring</li> <li>(14) Center Pulley Holder</li> <li>(15) Center Pulley Holder Reamer Bolt</li> <li>(16) Collar</li> </ul> <p><b>[A] RCK48-18BX, RCK54-23BX, RCK60B-23BX, RCK54D-26BX and RCK60D-26BX</b></p> <p><b>[B] RCK48P-18BX and RCK54P-23BX</b></p> |
|--|---|

9Y1210855MOS0024US0

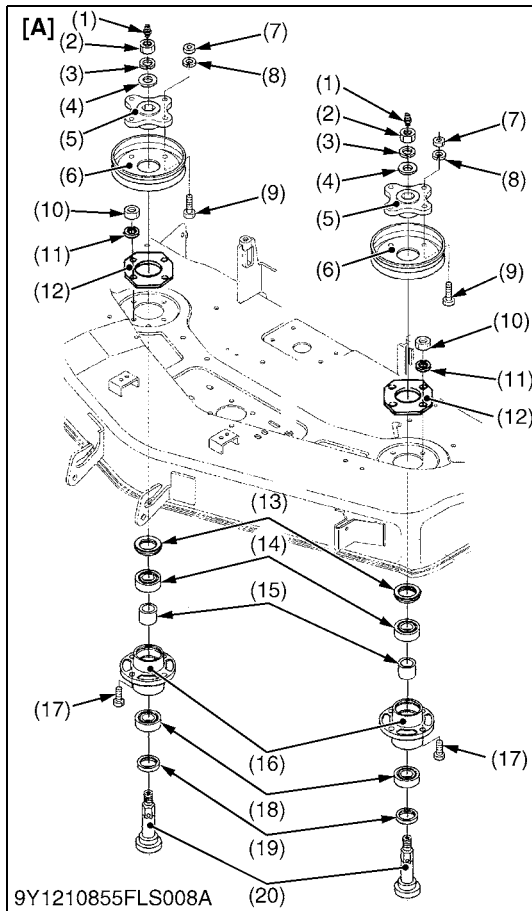

**Outer Pulley and Blade Shaft [RCK48-18BX, RCK54-23BX, RCK60B-23BX, RCK54D-26BX and RCK60D-26BX]**

1. Remove the outer pulley mounting nut (2), and remove the outer pulley (6).
2. Remove the outer pulley holder mounting nut (10), and remove the outer pulley holder (16).
3. Remove the oil seal (13) and tap out the blade shaft (20) with the ball bearing (18) and (14), taking care not to damage the grease fitting (1).
4. Remove the ball bearing (14), and collar (15) from the blade shaft (20).
5. Remove the ball bearing (18), and oil seal (19).

**(When reassembling)**

- Replace the oil seals (13) and (19) with new ones.

Tightening torque	Outer pulley mounting nut	197 to 225 N·m 20.0 to 23.0 kgf·m 145 to 166 lbf·ft
	Pulley boss mounting nut	24 to 27 N·m 2.4 to 2.8 kgf·m 18 to 20 lbf·ft
	Outer pulley holder mounting bolt and nut (RCK48-18BX)	48.0 to 55.9 N·m 4.9 to 5.7 kgf·m 35.4 to 41.2 lbf·ft
	Outer pulley holder mounting bolt and nut (RCK54-23BX, RCK60B-23BX, RCK54D-26BX and RCK60D-26BX)	78 to 90 N·m 7.9 to 9.2 kgf·m 58 to 66 lbf·ft

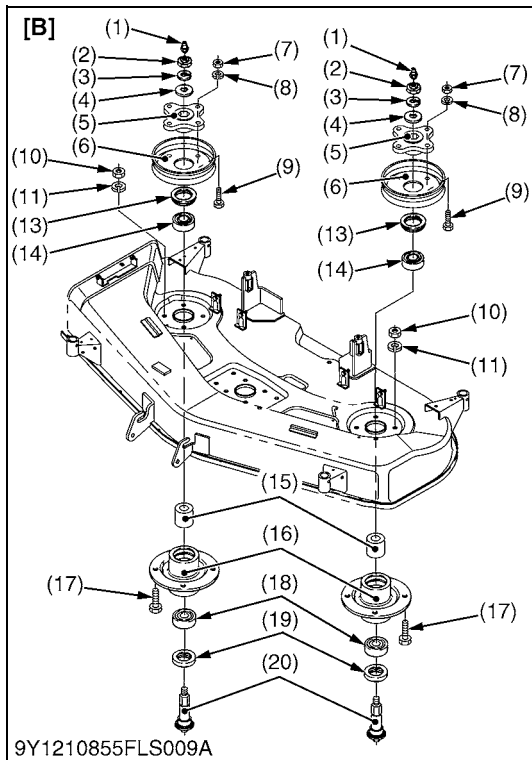

- |   |   |
|---|---|
| <ul style="list-style-type: none"> <li>(1) Grease Fitting</li> <li>(2) Outer Pulley Mounting Nut</li> <li>(3) Spring Washer</li> <li>(4) Plain Washer</li> <li>(5) Outer Pulley Boss</li> <li>(6) Outer Pulley</li> <li>(7) Nut</li> <li>(8) Spring Washer</li> <li>(9) Pulley Boss Mounting Bolt</li> <li>(10) Nut</li> <li>(11) Spring Washer</li> <li>(12) Pulley Holder Plate (RCK48-18BX)</li> </ul> | <ul style="list-style-type: none"> <li>(13) Oil Seal</li> <li>(14) Ball Bearing</li> <li>(15) Collar</li> <li>(16) Outer Pulley Holder</li> <li>(17) Outer Pulley Holder Mounting Bolt</li> <li>(18) Ball Bearing</li> <li>(19) Oil Seal</li> <li>(20) Blade Shaft</li> </ul> |
|---|---|
- [A] RCK48-18BX**  
**[B] RCK54-23BX, RCK60B-23BX, RCK54D-26BX and RCK60D-26BX**

9Y1210855MOS0025US0

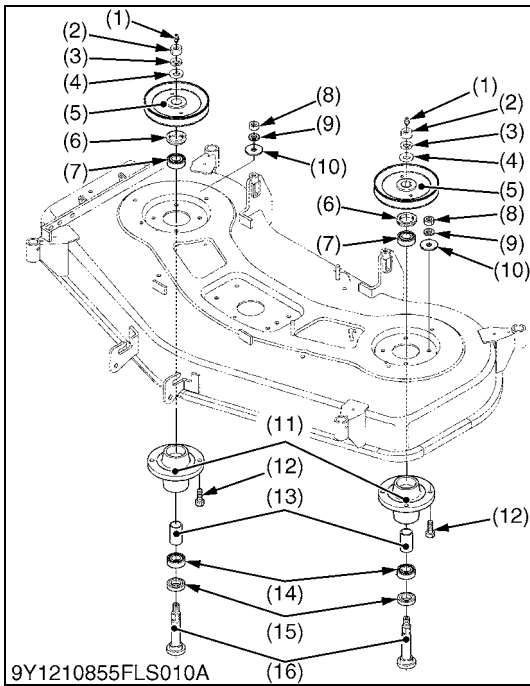

**Outer Pulley and Blade Shaft [RCK48P-18BX and RCK54P-23BX]**

1. Remove the outer pulley mounting nut (2), and remove the outer pulley (5).
2. Remove the outer pulley holder mounting nut (8), and remove the outer pulley holder (11).
3. Remove the oil seal (6) and tap out the blade shaft (16) with the ball bearings (14) and (7), taking care not to damage the grease fitting (1).
4. Remove the ball bearing (7) and collar (13) from the blade shaft (16).
5. Remove the ball bearing (14) and oil seal (15).

**(When reassembling)**

- Replace the oil seals (6) and (15) with new ones.

Tightening torque	Outer pulley mounting nut	167 to 186 N·m 17.0 to 19.0 kgf·m 123 to 137 lbf·ft
	Outer pulley holder mounting bolt and nut	48.0 to 55.9 N·m 4.9 to 5.7 kgf·m 35.4 to 41.2 lbf·ft

- |                               |  |
|-------------------------------|--|
| (1) Grease Fitting            | (9) Spring Washer                      |
| (2) Outer Pulley Mounting Nut | (10) Plain Washer                      |
| (3) Spring Washer             | (11) Outer Pulley Holder               |
| (4) Plain Washer              | (12) Outer Pulley Holder Mounting Bolt |
| (5) Outer Pulley              | (13) Collar                            |
| (6) Oil Seal                  | (14) Ball Bearing                      |
| (7) Ball Bearing              | (15) Oil Seal                          |
| (8) Nut                       | (16) Blade Shaft                       |

9Y1210855MOS0026US0

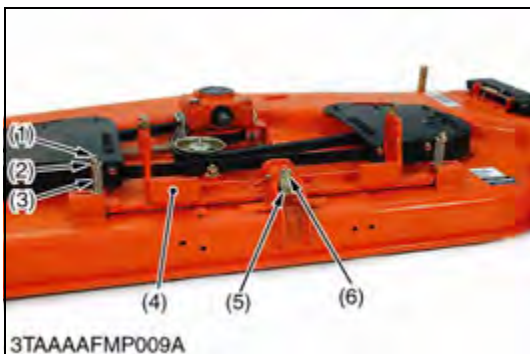

**Balancer**

1. Remove the lock nut (1) both side.
2. Remove the plain washer (2) and balancer spring (3).
3. Remove the center pin bolt (6).
4. Remove the center pin (5) and balancer plate (4).

**(When reassembling)**

- Apply grease to the center pin (5).
- Adjust the balancer spring (3) length to the factory specification, with lock nut (1).

Balancer spring length "L" (Right and left)	Factory specification	55.0 mm 2.17 in.
---	-----------------------	---------------------

- |                     |                     |
|---------------------|---------------------|
| (1) Lock Nut        | (4) Balancer Plate  |
| (2) Plain Washer    | (5) Center Pin      |
| (3) Balancer Spring | (6) Center Pin Bolt |

9Y1210855MOS0027US0

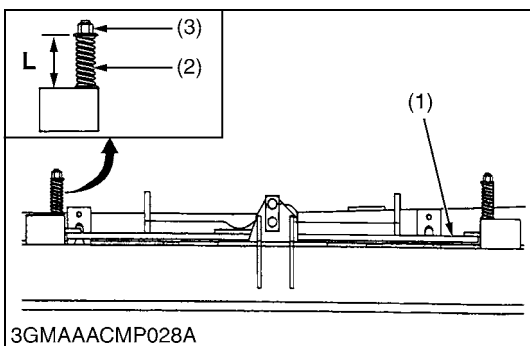

## [2] SERVICING

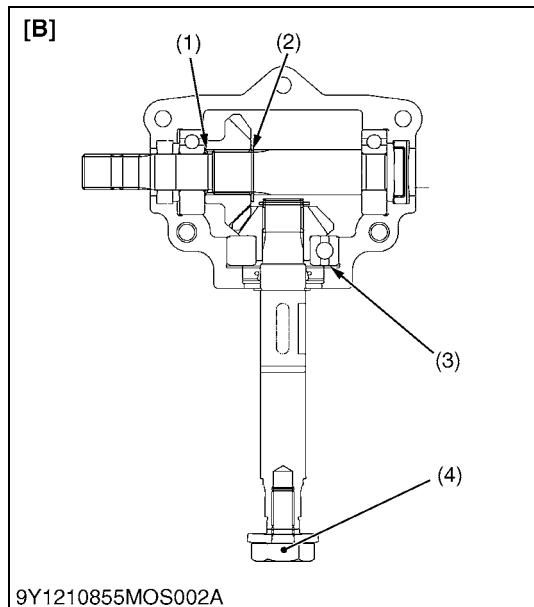
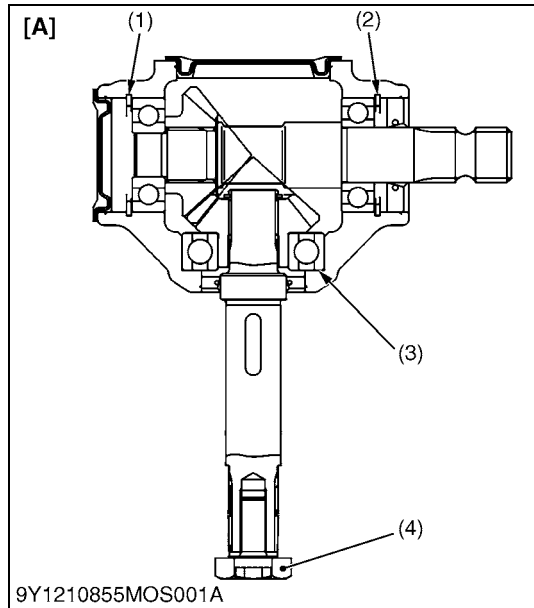

### Turning Torque of Pinion Shaft

1. Set the blade screw (4) for the blade shaft to measure the turning torque.
2. Turn the blade screw (4) clockwise with torque wrench and measure the turning torque

Turning torque	Factory specification	Less than 0.7 N·m 0.07 kgf·m 0.52 lbf·ft
----------------	-----------------------	---

### (Reference)

- Thickness of adjusting shims (1), (2):  
0.2 mm (0.0079 in.)  
0.3 mm (0.0118 in.)
- Thickness of adjusting shims (3):  
0.2 mm (0.0079 in.)  
0.3 mm (0.0118 in.)

- (1) Adjusting Shim
- (2) Adjusting Shim
- (3) Adjusting Shim
- (4) Blade Screw

[A] RCK48-18BX, RCK54-23BX,  
RCK60B-23BX, RCK54D-26BX  
and RCK60D-26BX

[B] RCK48P-18BX and RCK54P-23BX

9Y1210855MOS0028US0

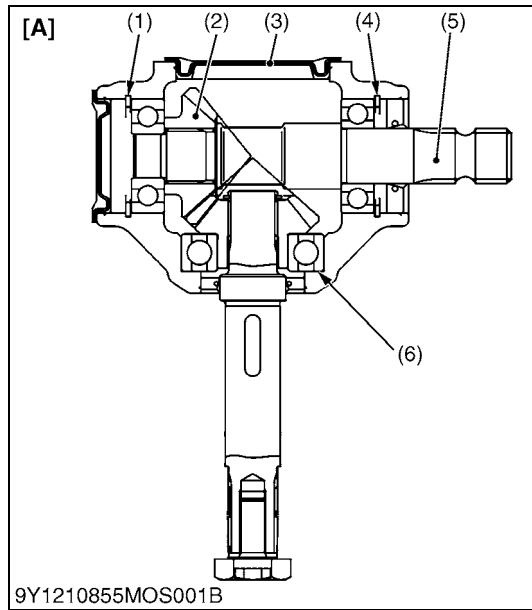

**Backlash between Bevel Gears**

1. Remove the gear box cap (3).
2. Place the plastigauges or wire of solder the bevel gear (2) on the input shaft (5).
3. Turn the input shaft (5).
4. Remove the plastigauges or wire of solder, and measure the thickness with the gage or an outside micrometer.
5. If the backlash exceeds the allowable limit, adjust with shims (1), (4), (6).

**[RCK48-18BX, RCK54-23BX, RCK60B-23BX, RCK54D-26BX and RCK60D-26BX]**

Backlash between bevel gears	Factory specification	0.10 to 0.20 mm 0.0040 to 0.0078 in
	Allowable limit	0.40 mm 0.016 in.

**(Reference)**

- Thickness of adjusting shims (1), (4):  
0.2 mm (0.0079 in.)  
0.3 mm (0.0118 in.)
- Thickness of adjusting shims (6):  
0.1 mm (0.0039 in.)  
0.2 mm (0.0079 in.)

**[RCK48P-18BX and RCK54P-23BX]**

Backlash between bevel gears	Factory specification	0.13 to 0.25 mm 0.0051 to 0.0098 in.
	Allowable limit	0.40 mm 0.016 in.

**(Reference)**

- Thickness of adjusting shims (1), (4):  
0.2 mm (0.0079 in.)  
0.3 mm (0.0118 in.)
- Thickness of adjusting shims (6):  
0.2 mm (0.0079 in.)  
0.3 mm (0.0118 in.)

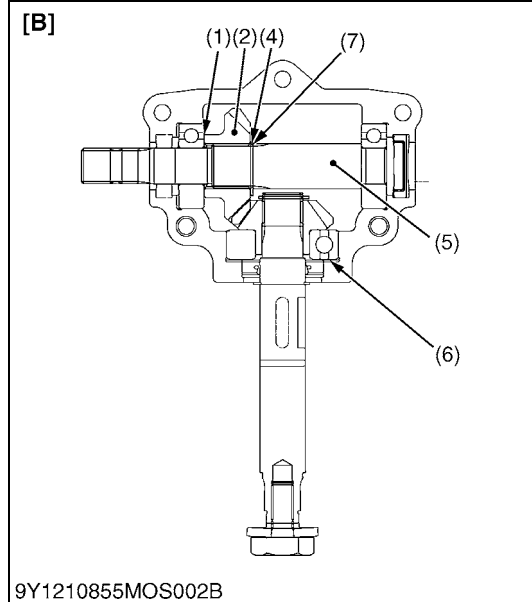

- |  |                      |
|--|----------------------|
| (1) Shim   | (4) Shim             |
| (2) 21T Bevel Gear<br>(RCK48-18BX and RCK48P-18BX) | (5) Input Shaft      |
| 19T Bevel Gear<br>(RCK54-23BX and RCK54P-23BX)     | (6) Shim             |
| 18T Bevel Gear<br>(RCK60B-23BX)                    | (7) External Circlip |
| (3) Gear Box Cap                                   |                      |

**[A] RCK48-18BX, RCK54-23BX,  
RCK60B-23BX, RCK54D-26BX  
and RCK60D-26BX**

**[B] RCK48P-18BX and RCK54P-23BX**

9Y1210855MOS0029US0



# **8 FRONT LOADER**

# MECHANISM

## CONTENTS

1. HYDRAULIC CIRCUIT SCHEMATIC .....	8-M1
2. CONTROL VALVE ASSEMBLY .....	8-M2
3. BOOM CYLINDER AND BUCKET CYLINDER .....	8-M3

# 1. HYDRAULIC CIRCUIT SCHEMATIC

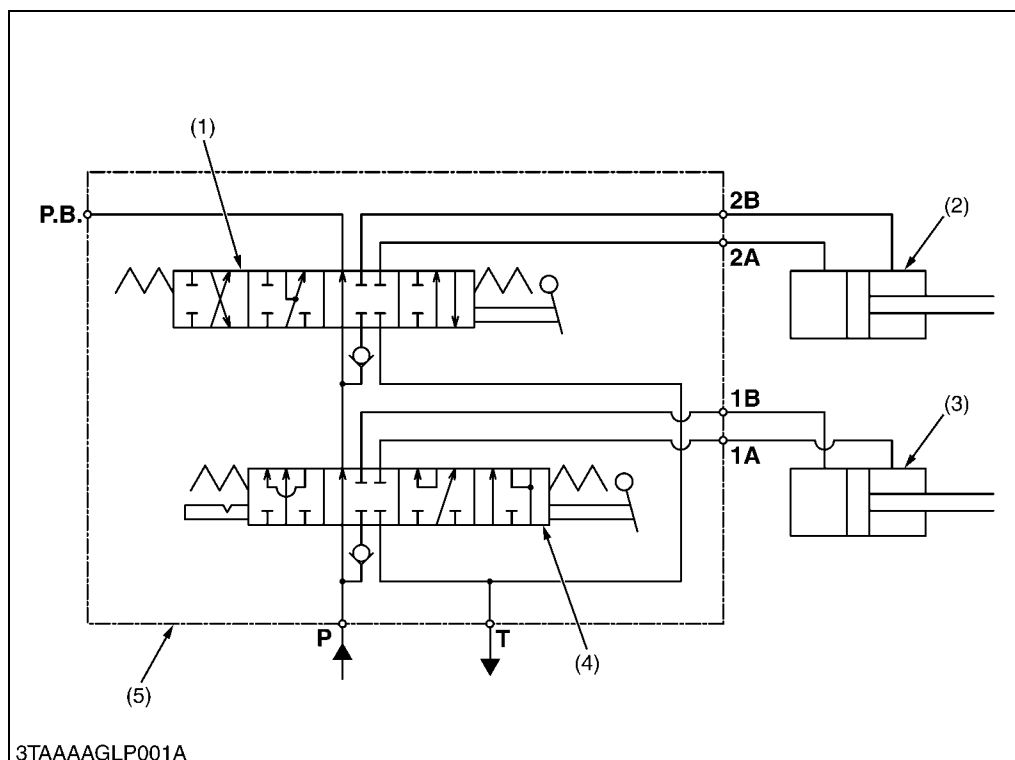

- (1) Bucket Control Valve
- (2) Bucket Cylinder
- (3) Boom Cylinder
- (4) Boom Control Valve
- (5) Control Valve Assembly

**P:** From Pump  
**P.B.:** To 3 Point Hydraulic System  
**T:** To Tank  
**1A:** 1A Port  
**2A:** 2A Port  
**1B:** 1B Port  
**2B:** 2B Port

To operate the front loader, the hydraulic oil pressurized by the hydraulic pump flows from **P** port through the boom control valve (4) and the bucket control valve (1) to **P.B.** port or **T** port.

Since relief valve is not equipped in the front loader control valve, the main relief valve in the tractor operates.

9Y1210855FLM0001US0

## **2. CONTROL VALVE ASSEMBLY**

1. Refer to the "5. HYDRAULIC SYSTEM" section. (See page 5-M12.)

9Y1210855FLM0002US0

### 3. BOOM CYLINDER AND BUCKET CYLINDER

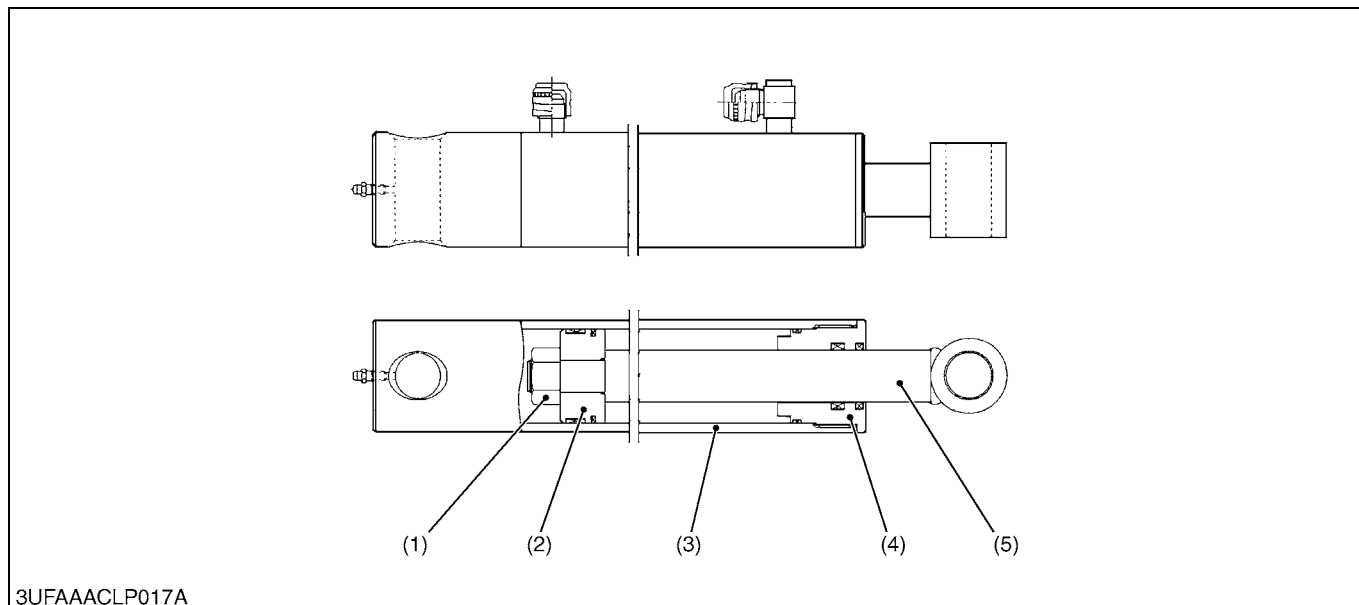

- (1) Nut
- (2) Piston
- (3) Cylinder Tube
- (4) Head
- (5) Piston Rod

Both boom cylinder and bucket cylinder consists of a head (4), cylinder tube (3), piston rod (5), piston (2), and other parts as shown in the figure above. They are single-rod double acting cylinder in which the reciprocating motion of the piston is controlled by hydraulic force applied to both of its ends.

**Cylinder Specifications**

		LA203	LA243
Boom Cylinder	Cylinder I.D.	40 mm (1.57 in.)	
	Rod O.D.	25 mm (0.98 in.)	
	Stroke	281 mm (11.1 in.)	326 mm (12.8 in.)
Bucket Cylinder	Cylinder I.D.	65 mm (2.56 in.)	
	Rod O.D.	30 mm (1.18 in.)	
	Stroke	204 mm (8.03 in.)	

9Y1210855FLM0003US0

# SERVICING

## CONTENTS

1. TROUBLESHOOTING.....	8-S1
2. SERVICING SPECIFICATIONS.....	8-S2
3. TIGHTENING TORQUES.....	8-S3
4. DISASSEMBLING AND SERVICING.....	8-S4
[1] DISMOUNTING AND MOUNTING FRONT LOADER.....	8-S4
(1) Dismounting Front Loader From Tractor.....	8-S4
(2) Mounting Front Loader to Tractor.....	8-S5
[2] FRONT LOADER.....	8-S6
(1) Bucket, Boom and Hydraulic Cylinders.....	8-S6
(2) Side Frames, Front Guard and Main Frames.....	8-S9
[3] SERVICING.....	8-S10

# 1. TROUBLESHOOTING

Symptom	Probable Cause	Solution	Reference Page
<b>Boom Does Not Rise</b>	Control valve malfunctioning	Repair or replace	5-S16
	Boom cylinder damaged	Repair or replace	8-S7
	Control lever linkage damaged	Repair or replace	5-S16
	Hydraulic pump malfunctioning	Repair or replace	5-S11
	Oil filter clogged	Clean or replace	G-22
	Hydraulic hose damaged	Replace	–
<b>Boom Does Not Lower</b>	Control valve malfunctioning	Repair or replace	5-S16
<b>Insufficient Boom Speed</b>	Boom cylinder tube worn or damaged	Replace	8-S7
	Boom cylinder piston ring (piston seal and O-ring) worn or damaged	Replace	8-S9
	Oil leaks from tube joints	Repair	8-S7
	Relief valve setting pressure too low	Adjust	5-S4
	Insufficient transmission fluid	Refill	G-32
	Dirty relief valve	Clean	5-S4
<b>Bucket Does Not Move</b>	Control valve malfunctioning	Repair or replace	5-S16
	Bucket cylinder damaged	Repair or replace	8-S7
	Control lever linkage damaged	Repair or replace	5-S16
	Hydraulic pump malfunctioning	Repair or replace	5-S11
	Oil filter clogged	Clean or replace	G-22
	Relief valve spring damaged	Replace	5-S4
	Hydraulic hose damaged	Replace	–
	Dirty relief valve	Clean	5-S4
<b>Insufficient Bucket Speed</b>	Bucket cylinder tube worn or damaged	Replace	8-S7
	Bucket cylinder piston ring (piston seal and O-ring) worn or damaged	Replace	8-S9
	Oil leaks from tube joints	Repair	–
	Insufficient transmission fluid	Refill	G-32
<b>Front End Loader Drops by its Weight</b>	Boom cylinder tube worn or damaged	Replace	8-S7
	Boom cylinder piston ring (piston seal and O-ring) worn or damaged	Replace	8-S9
	Oil leaks from tube joints	Repair	–
	Control valve malfunctioning	Repair or replace	5-S16

9Y1210855FLS0001US0

## 2. SERVICING SPECIFICATIONS

Item		Factory Specification	Allowable Limit
Piston Rod	Bend	–	0.25 mm 0.0098 in.

9Y1210855FLS0002US0



### 3. TIGHTENING TORQUES

Tightening torques of screws, bolts and nuts on the table below are especially specified.  
(For general use screws, bolts and nuts: Refer to "5. TIGHTENING TORQUES" on page G-13.)

Item	N·m	kgf·m	lbf·ft
Boom cylinder piston mounting nut	150 to 180	15.3 to 18.3	111 to 132
Bucket cylinder piston mounting nut	350 to 400	35.7 to 40.7	259 to 295
Main frame mounting screw (M14)	147	15.0	108

9Y1210855FLS0003US0

# 4. DISASSEMBLING AND SERVICING

## [1] DISMOUNTING AND MOUNTING FRONT LOADER

### ■ IMPORTANT

- When dismantling the loader, park the tractor on flat and hard ground, apply the parking brake.
- When starting the engine or using the hydraulic control valve, always sit in the operator's seat.

9Y1210855FLS0004US0

### (1) Dismounting Front Loader From Tractor

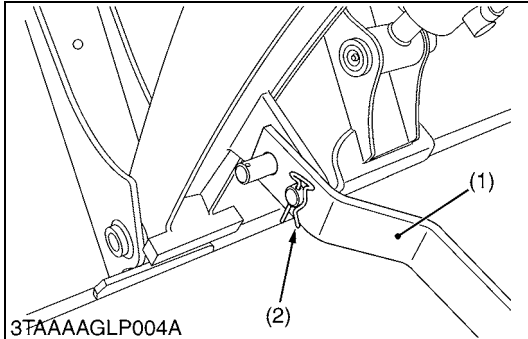

#### Side Frame

1. Raise the boom until the stands (1) can be rotated.
2. Stop the engine.
3. Remove the spring pin (2) holding the stand (1) to the boom.
4. Slide the stands (1) leftward and rotate it until the hole in the stand and pin on the boom are aligned. Then slide the stand (1) rightward and insert the spring pin (2) as shown.
5. Start the engine and run at idle.
6. Dump the bucket approximately 20 degrees.
7. Lower the boom and raise the front wheels slightly.

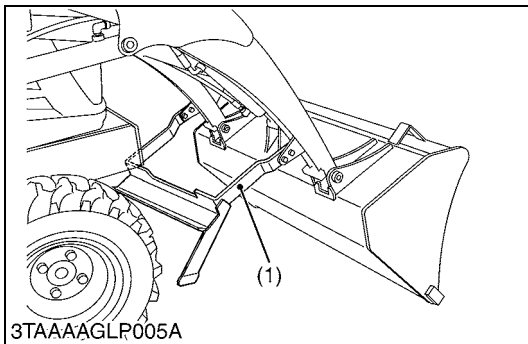

### ■ IMPORTANT

- Lift the front wheels with the bucket. Do not try to lift the with the stand.
8. Stop the engine.
  9. Remove the mounting pins from the loader side frames and hold them in the plate of side frame.
  10. Start the engine and run at idle. Slowly move the hydraulic control lever (3) to rollback position to raise the loader side frames up and out of the receives of the main frames as shown.
  11. Stop the engine.
  12. Slowly release all hydraulic pressure by moving the hydraulic control lever (3) in all directions.
  13. Disconnect the four hoses with quick couplers at the control valve and place them on the right side of the boom.
  14. Place the protective caps and plugs (4) on the quick coupler ends.
  15. Start the engine and slowly back the tractor away from the loader.

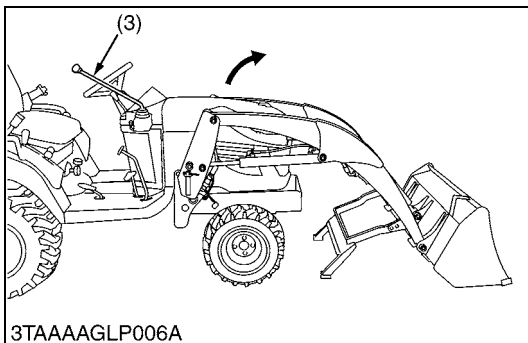

- |                |                             |
|----------------|-----------------------------|
| (1) Stand      | (3) Hydraulic Control Lever |
| (2) Spring Pin | (4) Protective Plug         |

9Y1210855FLS0005US0

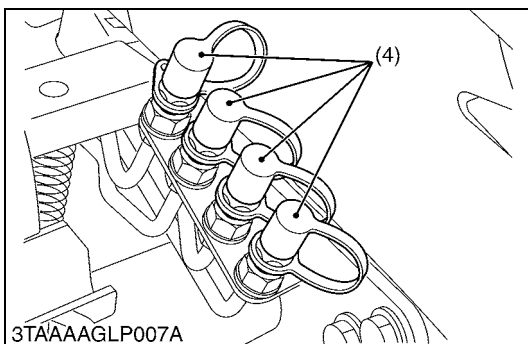

## (2) Mounting Front Loader to Tractor

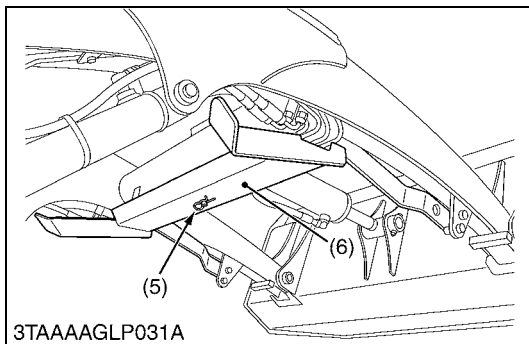
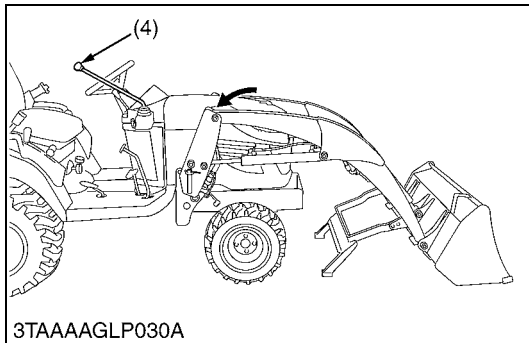
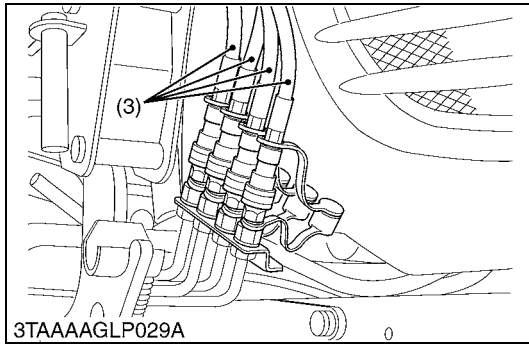
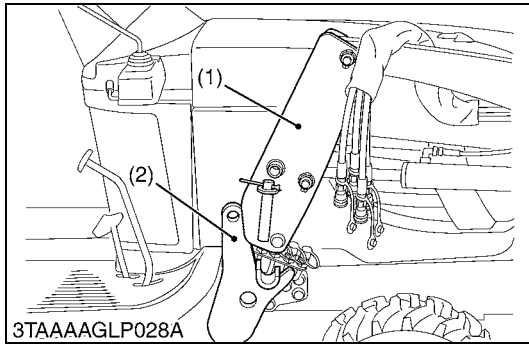

### Side Frame and Hoses

1. Slowly drive the tractor between the loader side frames until the rear portion of both side frames touches the main frames as shown.
2. Stop the engine.
3. Connect four hoses with couplers to the fitting on the control valve as indicated with color marks. Then connect the protective caps and plugs to each other.
4. Start the engine and run at idle.
5. Slowly move the loader control lever to dump position to lower the side frames into the main frames and engage the bosses of the main frames to the guide bosses of the side frames. Then lift the front wheels slightly with the loader.

### ■ IMPORTANT

- Do not try to lift the front wheels with the stand.
6. Stop the engine. Reinstall the mounting pins and secure them with the locking rods.
  7. Start the engine.
  8. Raise the boom until the stand can be rotated.
  9. Stop the engine.
  10. Store the stand to their original positions and secure it with the spring pin as shown.
  11. Start the engine.
  12. Lower the boom and level the bucket.

- |                |                          |
|----------------|--------------------------|
| (1) Side Frame | (4) Loader Control Lever |
| (2) Main Frame | (5) Spring Pin           |
| (3) Hose       | (6) Stand                |

9Y1210855FLS0006US0

## [2] FRONT LOADER

### (1) Bucket, Boom and Hydraulic Cylinders

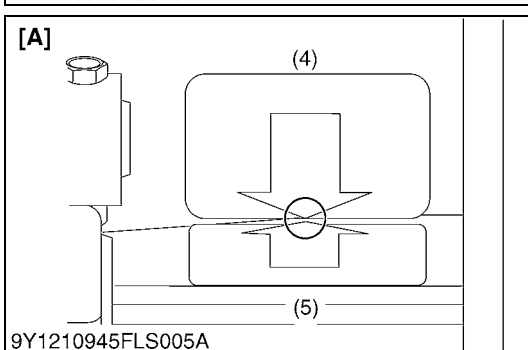
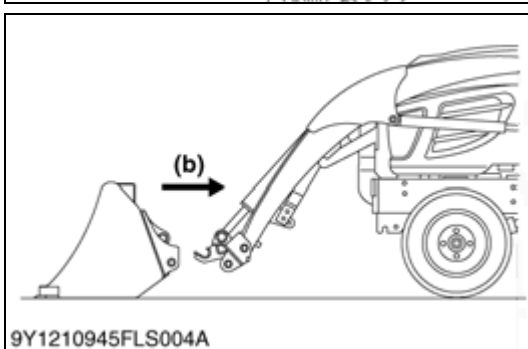
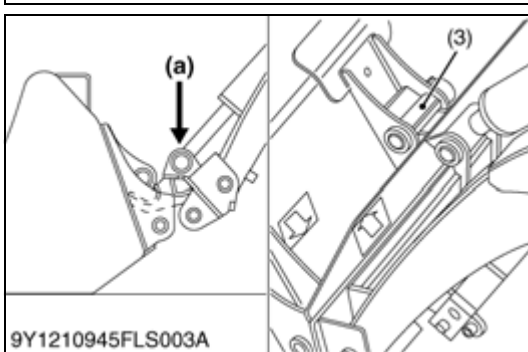
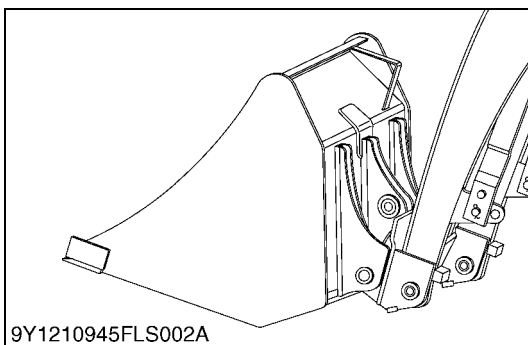
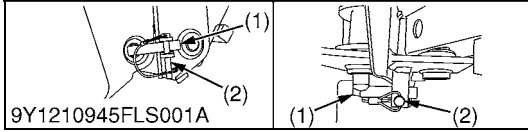
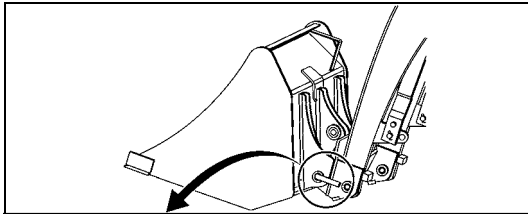

#### Bucket (Quick Hitch)

##### ■ NOTE

- Attachments should be located on a flat, firm surface when attaching and detaching them.

1. Remove the both snapper pins (2) and hitch pins (1).
2. Operate the loader control lever to the "Dump" position until the attachment at ground level.
3. Lower the boom of the loader until the quick coupler receivers comes off from the pin (3) at the upper bosses of the attachment seat.
4. Move the tractor rearward slowly.

##### (When reassembling)

- Be sure to assemble the hitch pins (1) and snapper pins (2) properly as shown the figure.
- Move the tractor slowly for forward until the arrow marker on the attachment label is close to that on the quick coupler label as shown figure.

- (1) Hitch Pin
- (2) Snapper Pin
- (3) Pin
- (4) Front Attachment Side
- (5) Quick Coupler Side

- (a) Lower
- (b) Move Rearward

- [A] When viewed from the operator's seat

9Y1210855FLS0017US0

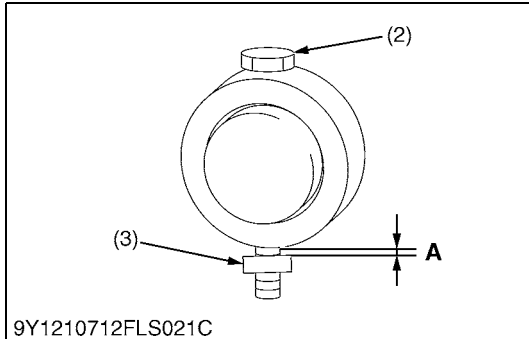
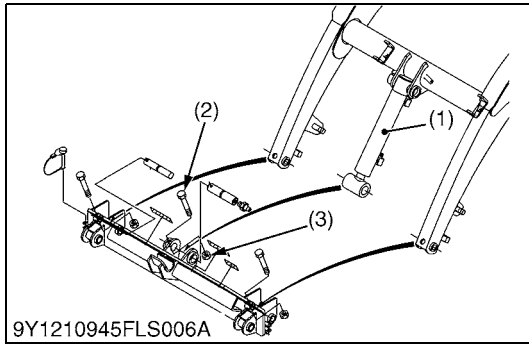

### Bucket Cylinder

#### ⚠ CAUTION

To avoid personal injury:

- Before you disconnect hydraulic hoses, be sure to release all pressure.

1. Disconnect the hydraulic hoses from the bucket cylinder.
2. Remove lower pin and upper pin and remove the bucket cylinder (1).

#### (When reassembling)

- To install the bucket cylinder (1), the hydraulic port must point inside and be careful of the direction of grease fittings.

#### ■ IMPORTANT

- When fixing the pin with the bolt (2) and nut (3), do not tighten the nut completely. The clearance: "A" between the boss and the nut must be 2 to 3 threads.

- |                     |         |
|---------------------|---------|
| (1) Bucket Cylinder | (3) Nut |
| (2) Bolt            |         |

9Y1210855FLS0018US0



### Boom Cylinder and Hydraulic Tubes

1. Disconnect the hydraulic hoses from the boom cylinders (4).
2. Remove the pins (2) and remove the boom cylinders (4).
3. Disconnect the hydraulic hoses (6) with quick couplers at the control valve.
4. Remove the pins (1) and remove the boom (3) from the side frame (5).
5. Remove the hydraulic tubes (7) from the boom (3).

#### (When reassembling)

- To install the boom cylinders (4), the hydraulic port must point inside and be careful of the direction of grease fittings.

- |                   |                    |
|-------------------|--------------------|
| (1) Pin           | (5) Side Frame     |
| (2) Pin           | (6) Hydraulic Hose |
| (3) Boom          | (7) Hydraulic Tube |
| (4) Boom Cylinder |                    |

9Y1210855FLS0008US0

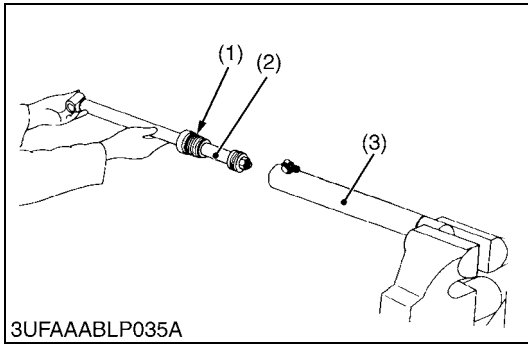

3UFAAABLP035A

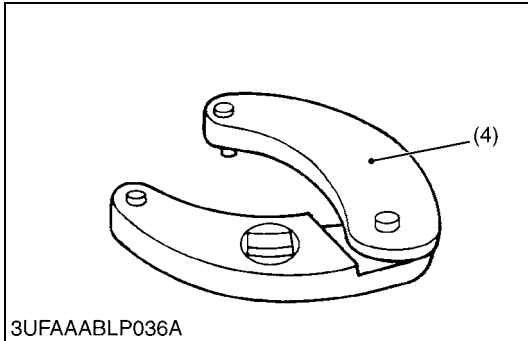

3UFAAABLP036A

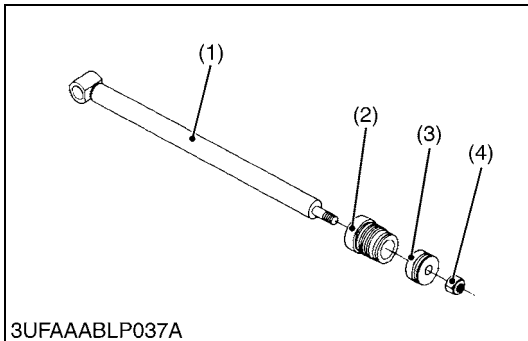

3UFAAABLP037A

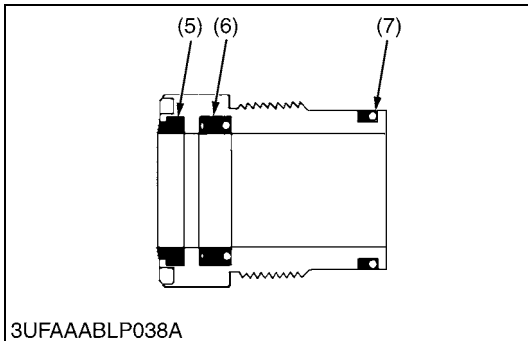

3UFAAABLP038A

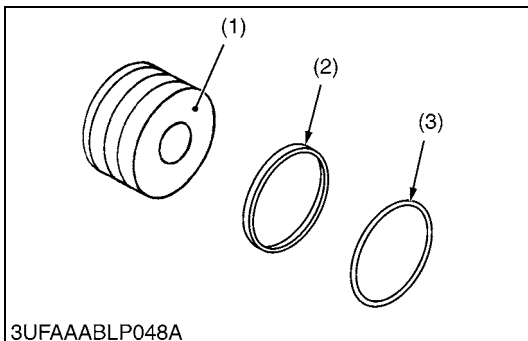

3UFAAABLP048A

### Piston Rod Assembly

1. Drain hydraulic oil from the cylinder, and secure the tube end of the cylinder in a vise.
2. Remove the cylinder head (1) with the adjustable gland nut wrench (4).
3. Pull out the piston rod assembly (2) from the cylinder tube (3).

#### (When reassembling)

- Visually inspect the cylinder tube for signs of scoring or damage.
- Insert the piston rod assembly to the cylinder tube, not to damage the piston seal on the piston.
- Install the cylinder head to the cylinder tube, not to damage the O-ring on the cylinder head.

- |                         |                                 |
|-------------------------|---------------------------------|
| (1) Cylinder Head       | (3) Cylinder Tube               |
| (2) Piston Rod Assembly | (4) Adjustable Gland Nut Wrench |

9Y1210855FLS0009US0

### Cylinder Head, Piston and Nut

1. Secure the rod end in a vise.
2. Remove the nut (4), and remove the piston (3) and cylinder head (2) from the piston rod (1).

#### (When reassembling)

- Visually inspect all parts for signs of scoring or damage.
- Insert the piston rod to the cylinder head, not to damage the wiper seal (5) and oil seal (6).

Tightening torque	Boom cylinder piston mounting nut	150 to 180 N·m 15.3 to 18.3 kgf·m 111 to 132 lbf·ft
	Bucket cylinder piston mounting nut	350 to 400 N·m 35.7 to 40.7 kgf·m 259 to 295 lbf·ft

- |                   |                |
|-------------------|----------------|
| (1) Piston Rod    | (5) Wiper Seal |
| (2) Cylinder Head | (6) Oil Seal   |
| (3) Piston        | (7) O-ring     |
| (4) Nut           |                |

9Y1210855FLS0010US0

### Piston Seal and O-ring

1. Remove the piston seal (2) and O-ring (3) from the piston (1).

#### ■ IMPORTANT

- When installing the O-ring (3) and piston seal (2) to the piston (1), use the slide jig and correcting jig as shown in "Special Tools" of "GENERAL" section.

- |                 |            |
|-----------------|------------|
| (1) Piston      | (3) O-ring |
| (2) Piston Seal |            |

9Y1210855FLS0011US0

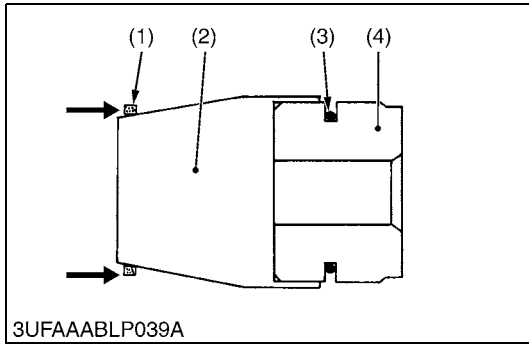

### Installing O-ring and Piston Seal

1. Place the slide jig (2) on the piston (4).
2. Install the O-ring (3) to the piston using the slide jig.
3. Install the piston seal (1) over the O-ring using the slide jig.
4. Compress the piston seal to the correct size by installing the piston into the correcting jig (5).

#### NOTE

- Do not turn (roll) the piston seal as you install it.

- |                 |                    |
|-----------------|--------------------|
| (1) Piston Seal | (4) Piston         |
| (2) Slide Jig   | (5) Correcting Jig |
| (3) O-ring      |                    |

9Y1210855FLS0012US0

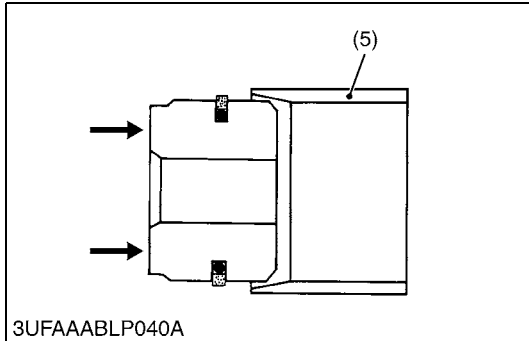

## (2) Side Frames, Front Guard and Main Frames

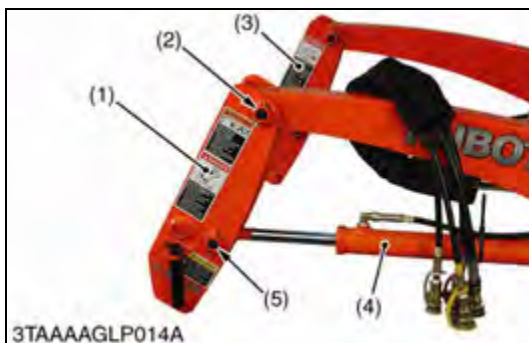

### Side Frames

1. Remove the pins (2), (5).
2. Remove the side frames (1) from the boom assembly (3) and the boom cylinder (4).

- |                   |                   |
|-------------------|-------------------|
| (1) Side Frame    | (4) Boom Cylinder |
| (2) Pin           | (5) Pin           |
| (3) Boom Assembly |                   |

9Y1210855FLS0013US0



### Front Guard

1. Remove the front guard (1).

- |                 |
|-----------------|
| (1) Front Guard |
|-----------------|

9Y1210855FLS0014US0

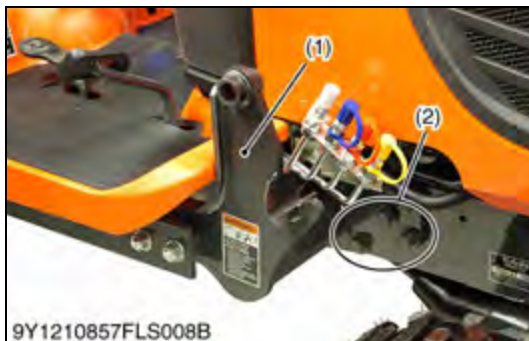

### Main Frames

1. Remove the main frame mounting screw (2) from the tractor body.
2. Remove the main frame (1).

Tightening torque	Main frame mounting screw (M14)	147 N·m 15.0 kgf·m 108 lbf·ft
-------------------	---------------------------------	-------------------------------------

- |                |                               |
|----------------|-------------------------------|
| (1) Main Frame | (2) Main Frame Mounting Screw |
|----------------|-------------------------------|

9Y1210855FLS0015US0

### [3] SERVICING

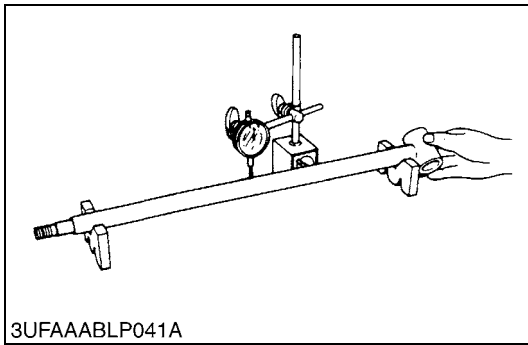

#### Piston Rod Bend

1. Place piston rod on V blocks.
2. Set a dial indicator on the center of the rod.
3. Turn the piston rod and read the dial indicator.
4. If the measurement exceeds the allowable limit, replace it.

Piston rod bend	Allowable limit	0.25 mm 0.0098 in.
-----------------	-----------------	-----------------------

9Y1210855FLS0016US0



---

**Editor** : Farm Machinery International Service Department  
**Address** : 64, Ishizu-Kitamachi, Sakai-Ku, Sakai-City, Osaka, 590-0823, Japan  
**Phone** : +81-72-241-1129  
**Fax** : +81-72-245-2484  
**E-mail** : ks\_g.ksos-pub@kubota.com

---